

Soleus GO! Fitness Band



Note that the actual color and artwork may vary from style to style.

How to Sync your GO! with your smart phone:

- Press and hold S1 of the Smart Band device from Time screen or Day/Date screen. The “**SYNC DATA**” appears/blinks followed by “**SYNC**” screen (w/ bar scrolling). Then tap the smart phone App to sync.

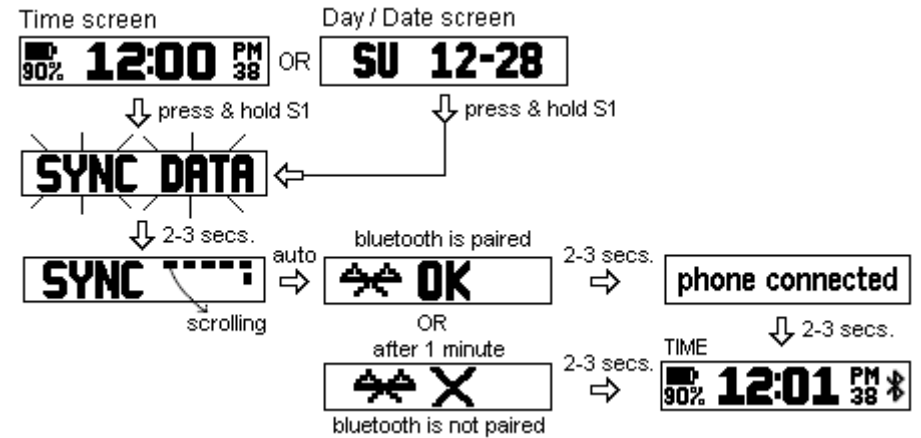

Notes:

- If sync is successful, the “**OK**” and Bluetooth icon appears. And 2-3 seconds later, it will show “**PHONE CONNECTED**”.
- If sync is unsuccessful, after 1 minute, the “**X**” and Bluetooth icon appears.
- In any mode, press and hold S1 button to turn off the Bluetooth. It will then display “**BLE OFF**”.

Getting to know your GO! Fitness Band

- Press **S1 button** to scroll the different modes; TIME, WEEKDAY/MONTH/DATE, CALORIE, DISTANCE, STEP, WEATHER/TEMP, PHONE, MESSAGE.

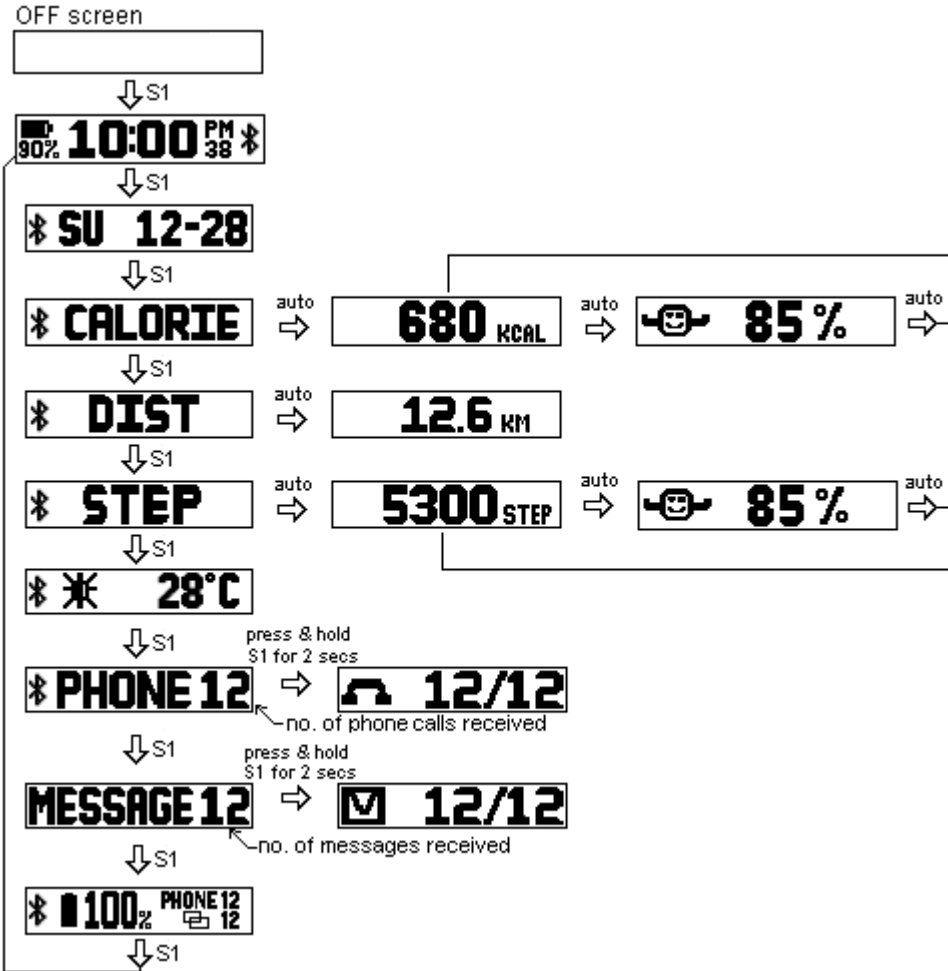

- Notes:
- If no Bluetooth connection, only TIME, WEEKDAY/MONTH/DATE, CALORIE and STEP will appear on the device.
 - The Weather/Temperature displayed on the GO! is from the Smartphone via Bluetooth connection.

- Press **S2 button** to scroll the different modes; EXERCISE, SLEEP, DATA, PAIR and SET mode.

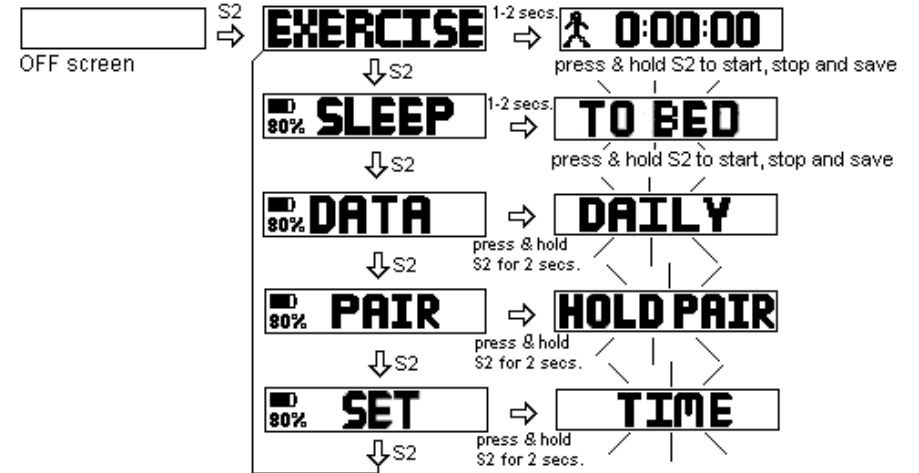

PHONE and MESSAGE

- Press and hold S2 button to enter phone data or message data.
- Press S1 button to view the data. The phone icon or message icon is shown with the date, day, time, etc.
- Press and hold S2 button to exit and it will automatically return to Time mode.

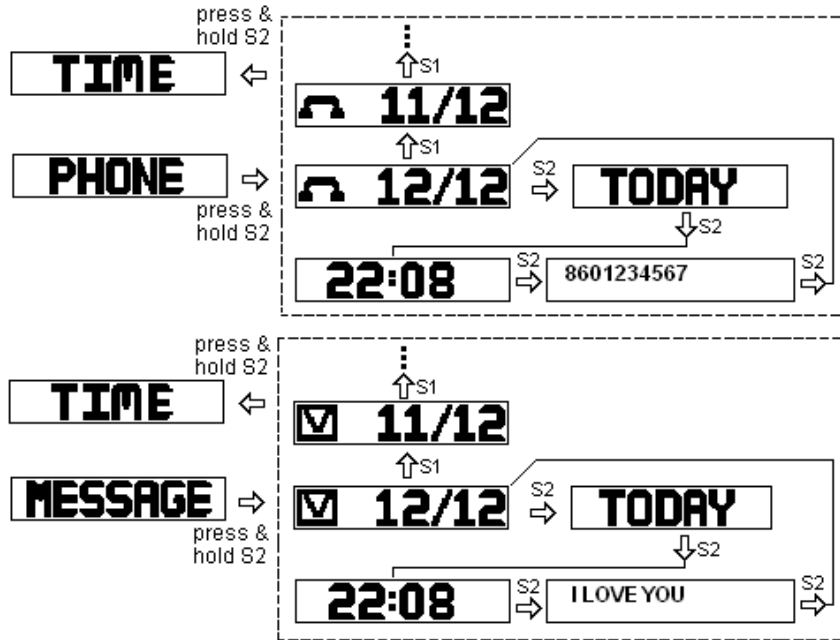

Receiving an Incoming call:

- In any screen, when receive an incoming call, the device will show the Caller ID (phone number or name). It will also scroll for 3 times with 20 seconds vibration (optional).
- Press S1 or S2 to exit and go Time mode.

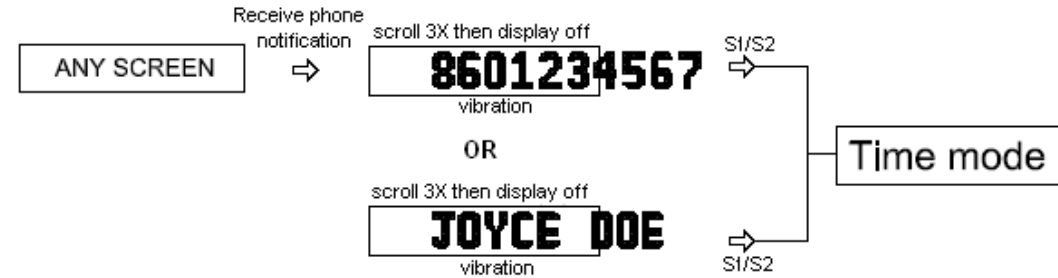

Receiving a Message:

- In any screen, when receive a message, the device will show the Sender's name/message or Sender's phone number/message. It will scroll for 3 times with 20 seconds vibration (optional).
- Press S1 or S2 to exit and go Time mode.

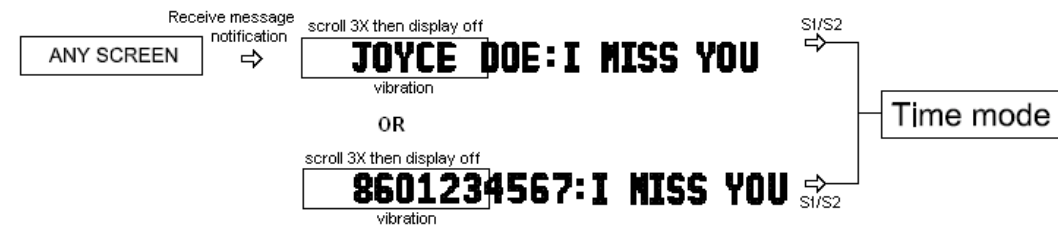

Notes:

- If no phone call or message data, it will display "NO DATA".
- Name or Phone number will be provided by the phone.
- Name, Phone number or SMS/Message limit is 32 characters max.

View your progress Goal CALORIE or STEP

While doing your exercise, you can view the progress of your Goal Calorie or Goal Steps.

- Press S1 button from OFF screen to enter CALORIE mode or
- Press S1 button from OFF screen to enter STEP mode

There are 5 display conditions:

	Description:	Display:
1	When your Calorie or Step reach 100% of your Goal.	100%
2	When your Calorie or Step reach 85% of your Goal.	85%
3	When your Calorie or Step reach 50% of your Goal.	50%
4	When your Calorie or Step reach 20% of your Goal.	20%
5	When your Calorie or Step has no activity.	0%

TIME mode

- Press S1 button from OFF screen to enter Time mode. It will then appear and blink human icon if EXERCISE is ON or running. Likewise, when SLEEP is ON or active, the human face icon will appear.

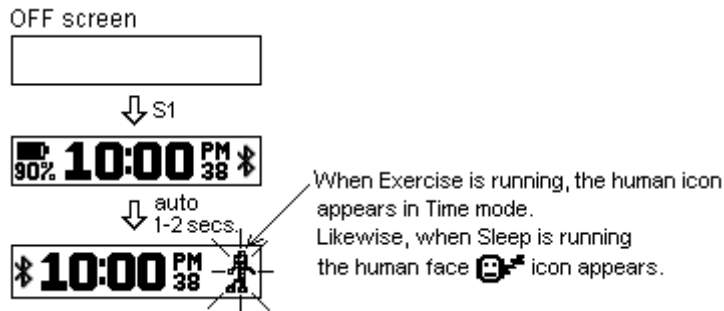

Note that this device has an auto OFF screen function. Press any of the buttons will turn ON the screen.

EXERCISE mode

- Press S2 button from OFF screen to enter EXERCISE mode.
- Press and hold S2 and wait until “HOLD START” stops blinking and release the button to start your exercise.

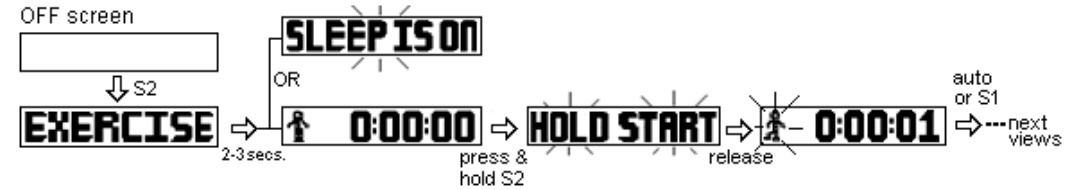

- Press and hold S2 and wait until “HOLD STOP” stops blinking then release the button to save your exercise. It will auto scroll EXERCISE, CALORIE, DISTANCE, PACE, SPEED and STEP.
- Press and hold S2 and wait until “HOLD SAVE” stops blinking then release the button to reset your current data.

Notes:

- When you go to SLEEP mode while the Exercise is ON or active, it will display “EXER IS ON”.
- There is no restart function.

SLEEP mode

- Press S2 button from OFF screen to enter SLEEP mode.
- Press and hold S2 and wait until “HOLD START” stops blinking and release the button to start your sleep activity.

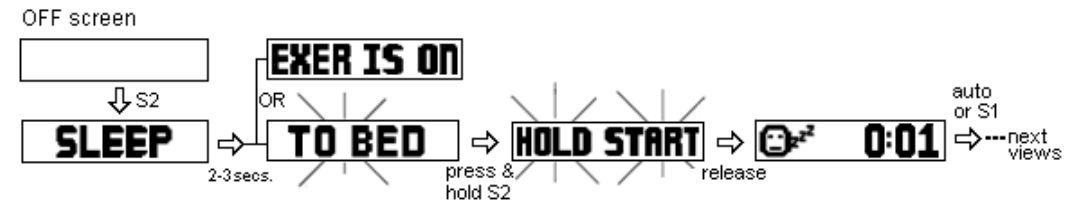

- Press and hold S2 and wait until “HOLD STOP” stops blinking then release the button to save. It will auto scroll the LS- Light sleep, DS- Deep sleep, WU- Wake-up time and TG- target % sleep .
- Press and hold S2 and wait until “HOLD SAVE” stops blinking then release the button to reset your current data. It will auto return TO BED screen.

Notes:

- When you go to EXERCISE mode while the SLEEP is ON or active, it will display “SLEEP IS ON”.
- SLEEP function can be set either MANUAL or AUTO in SET mode. If User will select “MANUAL”, you may press and hold S2 button to start/stop this function. If User will select “AUTO” it will automatically start/stop the sleep activity based on your preset sleep BED time and WAKE-UP time. The “GOOD NIGHT” and “GOOD MORNING” message will also automatically appears.
- There is no restart function.

DATA mode

How to view the Data

- Press S2 button from OFF screen to enter DATA mode.
- Press and hold S2 to enter DAILY data.
 - While DAILY is blinking, press S1 to select EXERCISE data, SLEEP data or DAILY data.
- Press S2 button to view the data.

Follow the function flow for Exercise & Sleep data as shown:

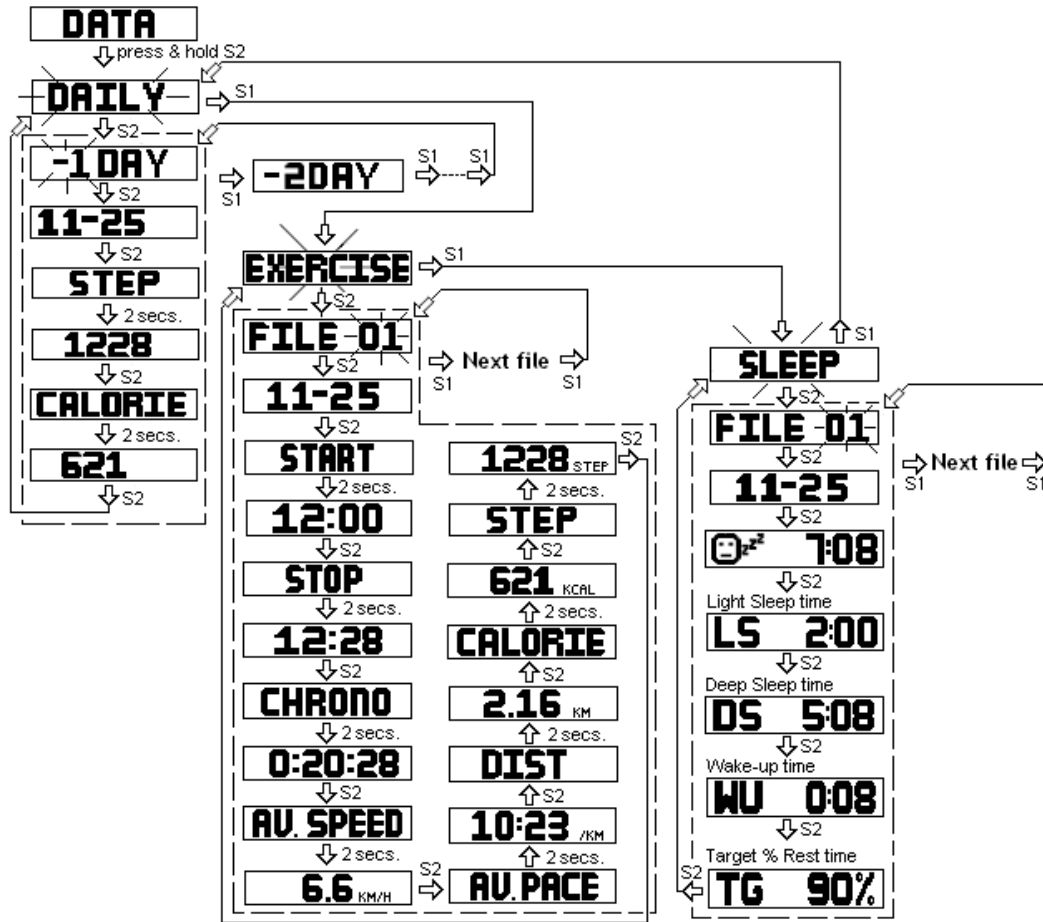

PAIR mode

- Press S2 button from display OFF screen to enter PAIR mode.
- Press and hold S2 button to enter Pair setting mode. "HOLD PAIR" appears/blinks and 2-3 seconds later, the "SEARCHING" screen appears followed by "PAIR" screen (w/ bar scrolling).
- Go to the Soleus GO! App to pair the device

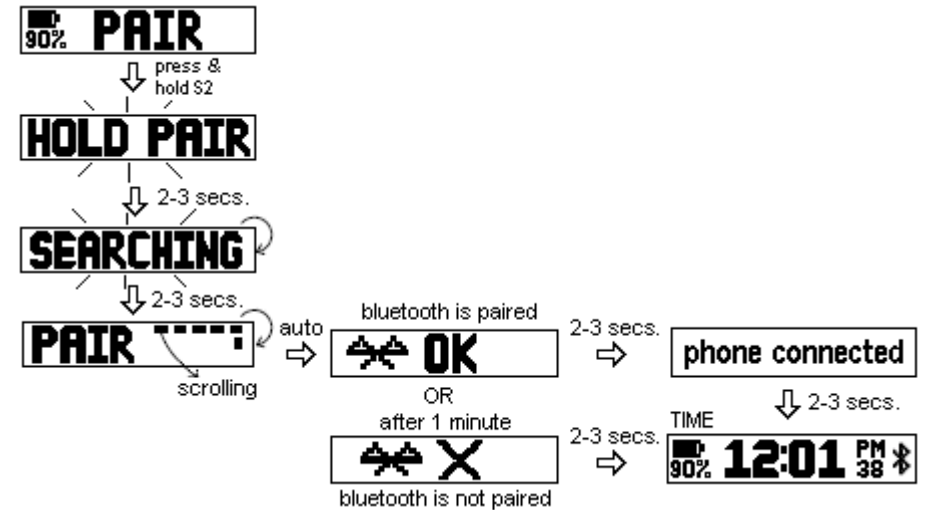

SET mode

- Press S2 button from display OFF screen to enter SET mode.
- Press and hold S2 button to enter setting mode. TIME appears and blinks.
- Press S1 button to scroll through the parameters to set: TIME → UNIT → USER → SLEEP → GOAL → MOVE TIME → VIBRATION → PAIR → back to Time.

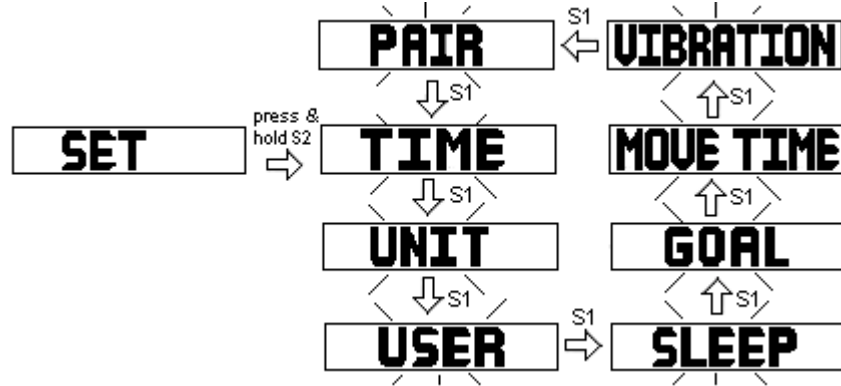

How to set the Time

- Press and hold S2 button until "TIME" appears and blinks.
- Press S2 to set the Hour → Minute → Seconds → Month → Day → Year → 12/24H → MM-DD / DD.MM and go back to Time mode.
- Press S1 button to change the blinking digit.
- Press S2 to confirm setting.

Please follow the function flow as shown:

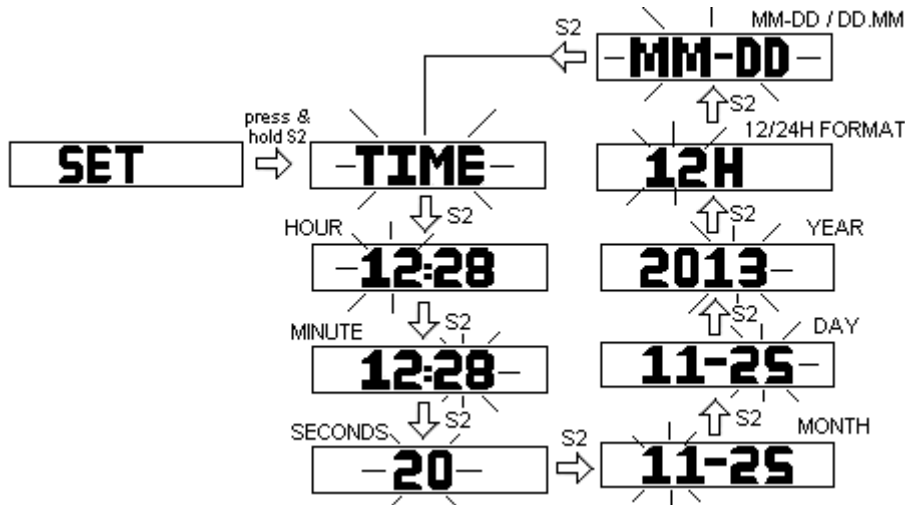

How to set the Unit

- Press S2 while **UNIT** is blinking. **KM** will start to blink.
- Press S1 to change KM to Mi or vice versa.
- Press S2 to confirm setting.



How to set the User

- Press S2 while **USER** is blinking. **GENDER** will start to blink.
- Press S1 to change the blinking digit.
- Press S2 to confirm setting.

Please follow the function flow as shown:

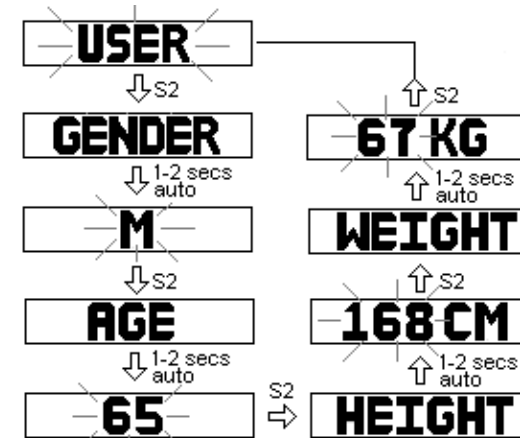

How to set the Sleep

- Press S2 while **SLEEP** is blinking. **MANUAL** or **AUTO** will start to blink.
- Press S1 to change the blinking digit.
- Press S2 to confirm setting.

Please follow the function flow as shown:

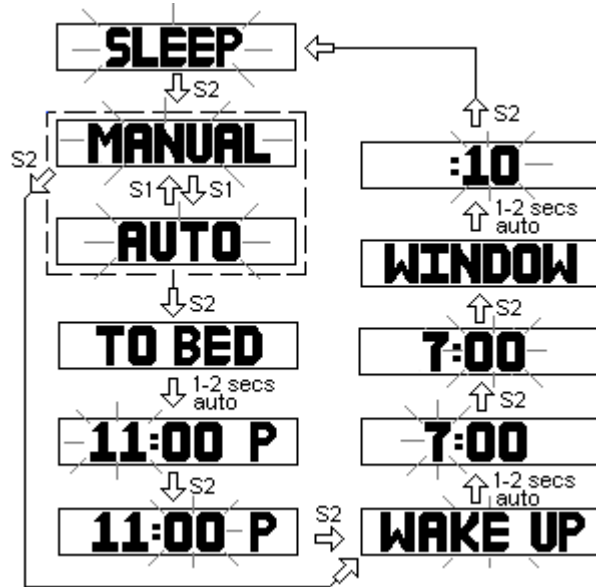

How to set the Goal Step or Calorie

- Press S2 while **GOAL** is blinking. **STEP** or **CALORIE** will start to blink.
- Press S2 to set the STEP or CALORIE.
- Press S1 to change the blinking digit.
- Press S2 to confirm setting.

Please follow the function flow as shown:

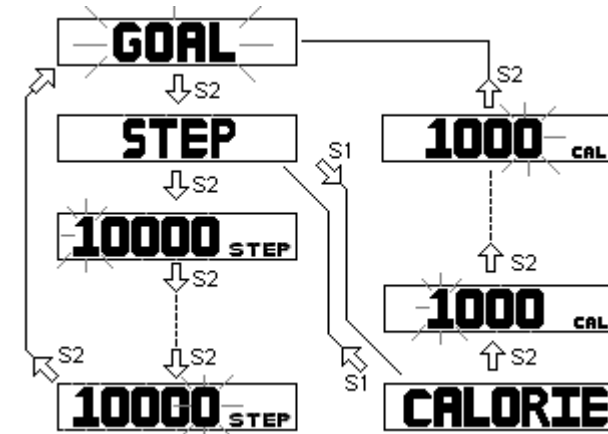

How to set the Move Time

- Press S2 while **MOVE TIME** is blinking. "0" digit will start to blink.
- Press S1 to change the blinking digit.
- Press S2 to confirm setting.

Please follow the function flow as shown:

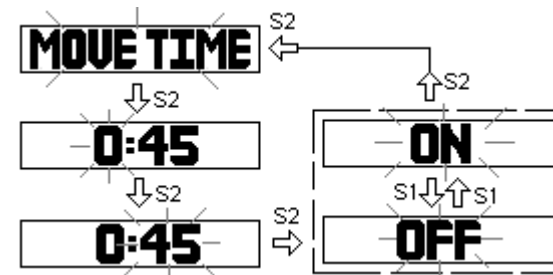

MOVE TIME function, Ex. Set to "0:45"(45 minutes), if User is not in motion within the time period of 45 minutes, the device will display "MOVE" with a 10 seconds vibration to remind the User that it is time to move.

How to set the Vibration Time

- Press S2 while **VIBRATION** is blinking.
- Press S1 to change the blinking digit.
- Press S2 to confirm setting.



How pair your GO! With Soleus GO! app

- Press S2 while "PAIR" is blinking. "SEARCHING" appears followed by "PAIR" screen (w/ bar scrolling).
- Pair your device with Soleus GO! App (tap the App to pair the device)

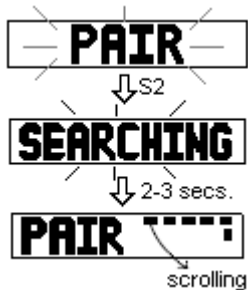

How to factory reset the GO!

In any screen, reset the GO! by pressing and holding S1 and S2 together for 5-6 seconds ("RESET" appears) then release the two (2) buttons.

Data Memory

Exercise data: 30 files
 Daily data: 30 days
 Sleep data: 10 days or 10 files

Battery Charge

GO! is using a rechargeable Lithium Ion battery. The device can be charged using the USB port and it takes about 3 hours to fully charge the battery. Please charge the device before using and never to hit empty.

Press any button from OFF screen to see the battery level during charging period.

Battery Life

Battery Life: Battery power will last for around 7 days on a single charge, depending on usage.

Battery Replacement

The battery on this device is not user replaceable and it is highly recommended by an authorized service personnel only.

Size and Weight

Device size (L x W x T): approx. 71.7 x 17.6 x 8.0 mm.
 Device weight: approx. 25.0 grams

Water Resistance

This device is an IPX7 standard which is capable of temporary immersion down to 1 meter