

Sovereign 22.5cc Petrol Hedge Trimmer

Operation and Maintenance Manual

QJB23



Technical Support & Parts

01904 727503

www.gardenservicecentre.co.uk

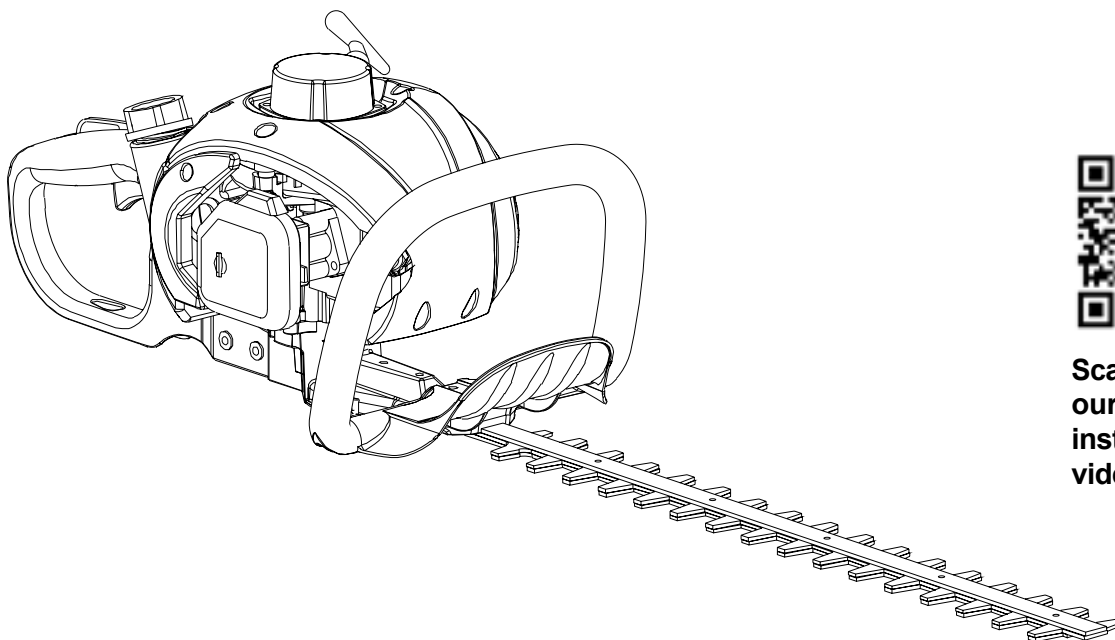

Scan to watch
our new
instruction
videos!

SOVEREIGN

Important - Please read these instructions fully before operating or maintaining your hedge trimmer

These instructions contain important information that will help you get the best from your hedge trimmer, ensuring it is assembled correctly and safely.

Contents

Safety Information.....	3
Warning Symbols.....	3
General Safety.....	4
Preparation.....	4
Operation.....	4
Maintenance and Storage.....	7
In the Box.....	8
Preparing to Operate the Hedge Trimmer.....	9
Step 1 - Filling with Engine Fuel.....	9
Operating the Hedge Trimmer.....	9
Step 1 - Removing the blade protector.....	10
Step 2 - Starting the Engine.....	10
Step 3 - Change rear handle position.....	11
Step 4 - Trimming.....	11
Stopping.....	12
Stopping.....	12
Cleaning the Air Filter.....	13
Replacing the Spark Plug.....	13
Storing the Hedge Trimmer.....	14
Step 1 - Storing the Hedge Trimmer for Short Periods.....	14
Step 2 - Storing the Hedge Trimmer for Extended Periods.....	14
Maintenance.....	14
Maintenance Schedule.....	14
Troubleshooting.....	15
Technical Data.....	16
Disposal.....	16
Getting Help.....	17
Guarantee.....	17

Safety Information

Important - Please read these instructions fully before operating or maintaining

Warning Symbols

The following warning symbols appear through this manual and indicate the appropriate safety measures you should take when operating and maintaining the hedge trimmer.



Before any use, refer to the corresponding paragraph in the present manual.



This symbol, before a safety comment, indicates a precaution, a warning or a danger. Ignoring this warning can lead to an accident for yourself or for others. To limit the risk of injury, fire, or electrocution always apply the recommendations indicated..



Conforms to European standards.



The exhaust gas is poisonous and asphyxiating. If inhaled it may even be lethal. Do not operate the engine in closed or poorly ventilated places.



Petrol and petrol vapours are extremely flammable.



Do not touch to prevent burns.

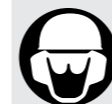

Wear hearing protection and eye protection when using the device.



Wear robust footwear when using the device.

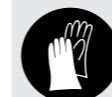

Wear protective gloves when using the device.

Safety Information

Important - Please read these instructions fully before operating or maintaining

General Safety



WARNING!

- Keep this operating and maintenance manual in a safe place for reference at a later date.
- Read the instructions carefully. Be familiar with the controls and the proper use of the equipment
- Never allow children or people unfamiliar with these instructions to use the hedge trimmer. Local regulations can restrict the age of the operator.
- Never trim while people, especially children, or pets are nearby. Keep in mind that the operator or user is responsible for accidents or hazards occurring to other people or their property.
- This appliance is not intended for use by persons (including children) with reduced physical, sensory or mental capabilities, or lack of experience and knowledge, unless they have been given supervision or instruction concerning use of the appliance by a person responsible for their safety.
- Do not touch blade.

Personal Safety



WARNING!

- Do not allow children or untrained individuals to use this unit;
- Never start or run the engine in a closed or poorly ventilated area; breathing exhaust fumes can kill;
- Clear the work area before each use. Remove all objects such as rocks, broken glass, nails, wire, or other such debris which can be thrown or become entangled in the cutting line or blade;
- Wear safety glasses or goggles when operating this unit;
- Wear heavy, long trousers, boots, and gloves. Do not wear loose fitting clothing, shorts, or go barefoot. Do not wear jewellery of any kind.

Operational Safety



WARNING!

- **Be careful about the environmental conditions you work under.** When started the motor will produce toxic gases. The gas can be invisible and odorless, therefore you should never operate the machine in an enclosed or badly ventilated area.
- When trimming ensure that the area is well lit. If you are trimming when it is raining, snowing or freezing on slopes or uneven terrain make sure you have a stable position.

Safety Information

Important - Please read these instructions fully before operating or maintaining

Operation (continued)

- Don't leave the machine unattended. Visitors and onlookers, especially children, and the infirm should be kept at a safe distance from your workplace. Make sure that other people cannot access an unattended machine.
 - Ensure safe tool storage. Machines that are not in use should be stored in a dry place if possible high up or they should be locked so that other people cannot gain access to them.
 - **Hedge trimmer transport.** The hedge trimmer is transported with a blade protection cover, when not in use replace this cover to prevent accidents. Secure the machine against tilting, damage and fuel leakage.
 - **Remove tool keys etc.** Before switching the hedge trimmer on remove all keys etc.
 - **Be always careful. Watch what you are doing.** When working use common sense. Do not use machinery if you are tired. Do not use the hedge trimmer under the influence of alcohol, drugs or medicines that lower the ability to concentrate.
 - **Fuel replenishment.** Before refuelling switch off the engine. Carefully open the fuel cap so that excess pressure can escape slowly and the fuel does not splash. The use of the trimmer results in high temperatures. Let the machine cool down before refuelling. Otherwise the fuel could ignite and people could get burnt. When refuelling make sure the fuel tank is not over filled and allows room for expansion. If the fuel leaks it is important to wipe up any leaked fuel and clear the machine. After refuelling ensure the fuel cap is sufficiently tight to prevent being loosened by the vibrations when the machine is at use.
 - **Usage period and breaks.** After a longer period of usage you might experience problems with blood circulation in your hands due to the vibrations. The period of usage can be extended by wearing suitable gloves and taking regular breaks. Please be aware that the time of usage is lowered by personal dispositions to bad circulation, a low outside temperature or a firm grip of the tool when working.
 - **Watch for damaged parts.** The machine should be carefully inspected before use. Are any of the parts damaged? In case of a slight damage consider if the machine is still going to work safely and without any problems. Make sure it is properly adjusted and movable parts are properly regulated. Are any elements interlocked improperly? Is everything well installed: Are all requirements for trouble free operation fulfilled? Damaged protective devices etc. must be repaired or replaced by the authorised service centres, unless expressly stated otherwise in the manual. Faulty switches should be replaced in the authorised centre. If you need to have your machine repaired, contact your nearest service centre.
 - Make sure that the protective cover of the hedge trimmer works perfectly and it is installed in such a way that the blade teeth are always covered.
 - Before adjustments or machine maintenance switch off the engine. This is valid mainly if the cutting blade is being replaced.
 - Use only approved components. During the maintenance and repairs use only identical spare parts. Contact your authorised service centre for this purpose.
-  **Caution!!** Using other cutting blades and other fixtures and extensions that are expressly not recommended can endanger people and property.

Safety Information

Important - Please read these instructions fully before operating or maintaining

Operation (continued)



WARNING! The cutting blade can hurt your hands and fingers and cause life threatening injuries! Always secure adequate lighting. The manufacturer cannot be liable if the machine was modified or used unprofessionally and damage arose as the result of these actions.

When handling the machine professionally there is always some risk that cannot be eliminated. The machine type and construction might present the following potential risks:

- a) Contact with an unprotected cutting blade (danger of cutting yourself)
 - b) Touching the trimmer in operation (danger of cutting yourself)
 - c) Unexpected, sudden movements of the cut material and its parts (danger of cutting yourself)
 - d) Spurning of faulty blade teeth and parts of cutting blade (danger of cutting yourself)
 - e) Hearing injuries if appropriate safety aids are not worn.
 - f) Creation of harmful dust or gas when using the machine in closed premises (sickness).
 - g) Do not use deformed or damaged cutting blades (cutting blade destruction).
- Switch off the engine before you start adjusting or maintaining the machine.
 - Make this instruction manual available to everybody who is working with the machine.
 - Use this machine only for trimming and cutting wood, max 22mm.
 - Do not use trimmers in the vicinity of flammable fluid or gas.
 - Have the machine repaired in an authorised service centre.
 - Do not attempt to repair the machine yourself. Repairs and part replacements can be carried out only by an authorised service centre.
 - Keep your workplace clean; remove trimmed waste and clear away objects you no longer require.
 - Be careful not to stumble in the vicinity of the trimmer.
 - Person working with the machine should not get disturbed.
 - Use only perfect cutting blades, e.g. well sharpened, without cracks, clinks, deformations etc.
 - Faulty cutting blades should be replaced immediately.
 - Do not use cutting blades that do not correspond with technical data stated in this instruction manual.
 - Make sure the cutting blade is installed in the right position.
 - Protective device of the machine can not be disassembled or made dysfunctional in any way.
 - Damaged or faulty protective devices should be immediately replaced.
 - If you get disturbed when working with the trimmer, act with prudence till you adapt your attention to a new situation.
 - At regular intervals check all screws, nuts and fittings are tight enough.
 - Never deposit tools or materials above the machine so that they could fall down on it.
 - Make sure your hands are in the right positions e.g. make sure they can not slide and suddenly and come in contact with the cutting blade.
 - The material you want to cut should not include nails or other similar foreign matters.
 - Do not overload the machine so it does not slow down and get overheated.
 - Never attempt to remove loose trimmings or wood fragments or jammed material when the machine is working.
 - If you want to remove some defects or clean the machine of jammed pieces of wood, you must switch it off first.
 - Machine adjustment, measuring, cleaning etc. is allowed only when the engine is switched off.

Safety Information

Important - Please read these instructions fully before operating or maintaining

Operation (continued)

- Do not leave an active engine unsupervised.
- After a repair or maintenance of safety or protective devices the devices must be reinstalled correctly in the machine.
- It is essential to know the regulations regarding accident prevention that are valid in a specific workplace and all other generally acknowledged safety regulations.
- When working pay attention to stability and maintain good balance.
- Check the machine on regular basis for signs of damage.
- Before using the machine you must check safety devices. Make sure that components that might seem slightly damaged still perform correctly.
- Check if all movable parts work perfectly. Concentrate mainly on the damaged and jammed components. All components must be installed properly and must comply with conditions for trouble free operation.
- Unless stated otherwise in the instruction manual the damaged components and safety devices should be repaired or replaced in an authorised service centre.
- Damaged switches should be replaced in an authorised service centre.
- The machine complies with all relevant safety provisions. Repairs can be carried out only by qualified repair staff in authorised centres using original spare parts. In case of non-compliance with the provision there is a danger of accident.
- Do not use the hedge trimmer if your concentration is lowered, after taking medication or if you are under the influence of alcohol or tired.
- The machine can be used only for the designed purpose. Any machine usage at variance with its purpose is considered unprofessional usage.
- The user is liable for the damage caused to property and injuries resulting from this unprofessional handling, and not the manufacturer.

Maintenance and Storage Safety

- Keep all nuts, bolts and screws tight to be sure the equipment is in safe working condition.
- Never store the equipment with petrol in the tank inside a building where fumes can reach an open flame or spark.
- Allow the engine to cool before storing in any enclosure.
- To reduce the fire hazard, keep the engine, silencer, battery compartment and petrol storage area free of hedge, leaves, or excessive grease.
- Replace worn or damaged parts for safety.
- If the fuel tank has to be drained, it should be done outdoors.

In the Box

Parts

A Hedge trimmer

Tools

1 Plug wrench & philips screwdriver
1pc

2 Mixing bottle

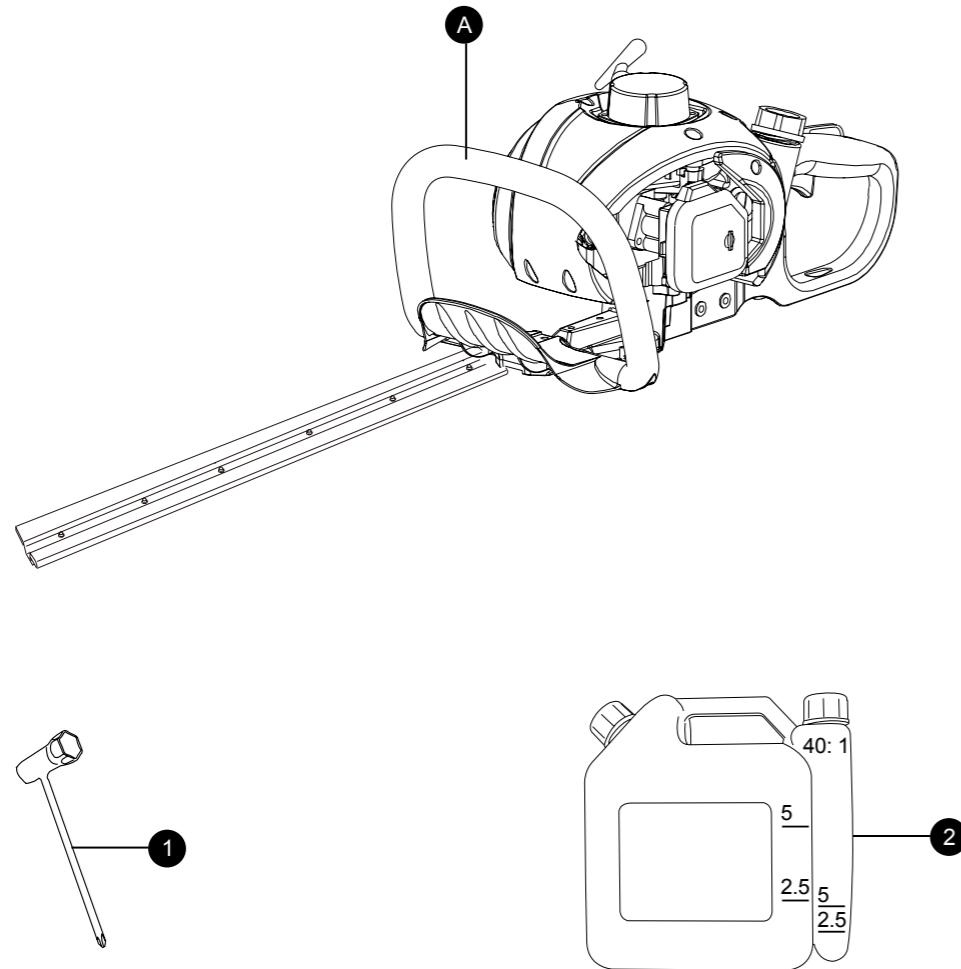

You will also need:

- 2 stroke oil
- Unleaded fuel
- Funnel

If there are any parts missing, please call the customer helpline on **01904 727503**

Preparing to Operate the Hedge Trimmer

Step 1 - Filling with Engine Fuel

! WARNING! Always shut off engine before fueling. Never add fuel to a machine with a running or hot engine. Move at least 30ft.(9 m) from refueling site before starting engine. Do not smoke!

! IMPORTANT! It is crucial that the fuel is mixed correctly - wrongly mixed fuel can cease the engine and voids the warranty. Carefully read these instructions, use the supplied bottle for mixing. When filling the mixing bottle, use a funnel while keeping the bottle flat to ensure a good reading.

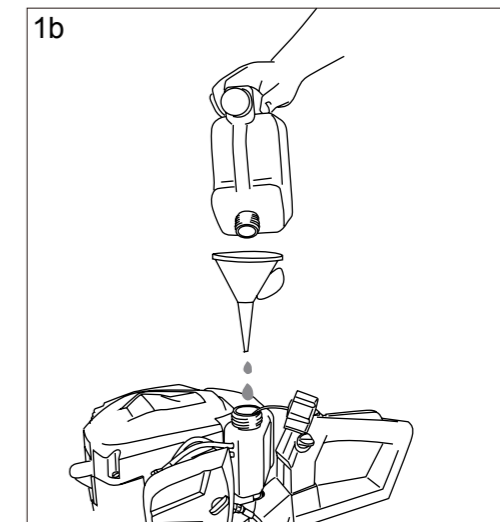
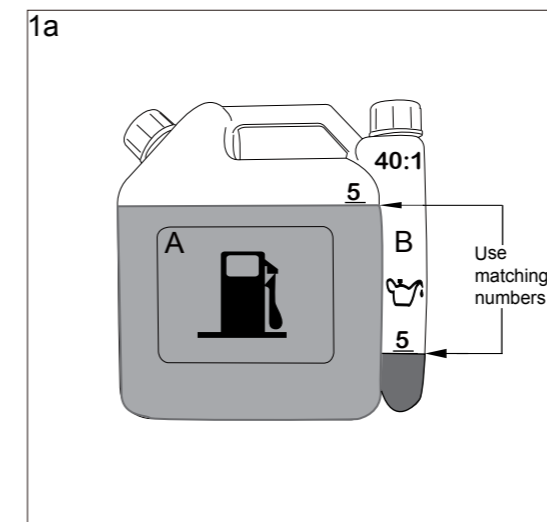

This product is powered by a 2-Stroke engine and requires pre-mixing of petrol and 2-stroke oil. Mix a high quality 2-Stroke engine oil according JASO FC classic. Do not use automotive oil or 2-cycle outboard oil. DO NOT mix quantities larger than usable in a 30 day period.

1a. FUEL MIXTURE: 1 Litre (1000 ml) petrol and 25cc (25 ml) 2 Stroke engine oil (40:1 ratio)

Using the markings under the label 40:1 on the bottle pour the fuel in the left hand side ('A') up to the required level eg 2.5 or 5 then fill the right hand side ('B') up to the same corresponding mark with oil. Please ensure that no fuel has leaked into B prior to pouring in oil. Shake vigorously to mix the two products prior to pouring into the tank of hedge trimmer.

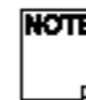

NOTE! Use 5 for 500ml fuel mixture and 2,5 for 250ml fuel mixture.

1b. FILLING TANK

Clean surface around fuel cap to prevent contamination. Loosen fuel cap slowly. Rest the cap on a clean surface. Carefully pour fuel into the tank using a funnel to avoid spillage. Prior to replacing the fuel cap,

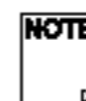

clean and inspect the seal located in the fuel cap. Immediately replace fuel cap and hand tighten. Wipe up any fuel spillage.

NOTE! It is normal for smoke to be emitted from a new engine after first use.

Operating the Hedge Trimmer

Step 1 - Removing the blade protector

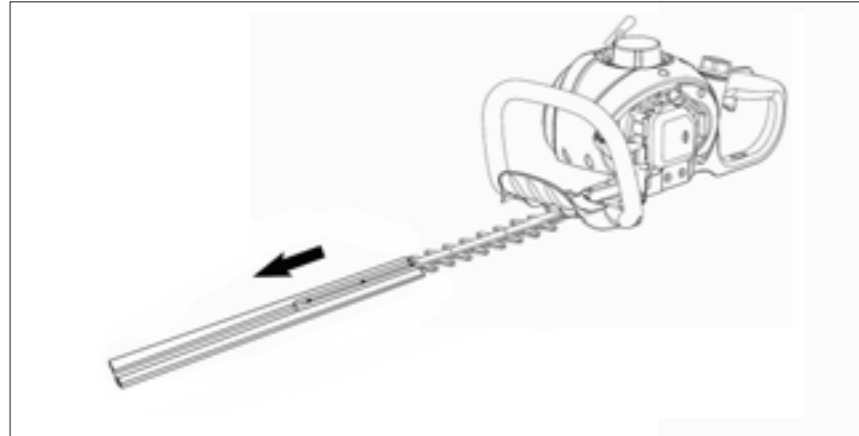

Remove the blade protector.

Step 2 - Starting the Engine

	Cold	Hot
1 Set START/STOP switch to START position		
2 Press primer bulb 7-10 times		
3 FULL CHOKE		
4 Pull cord so that motor turns over, (the engine may start)		
5 RUN position		
6 Pull cord until motor runs		

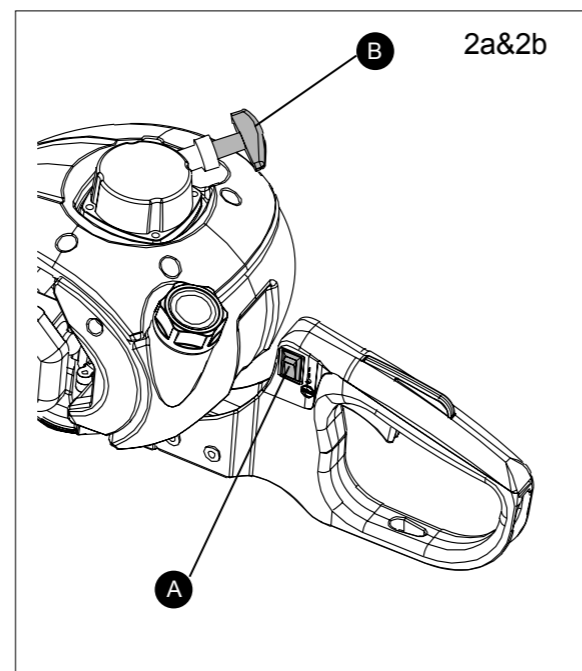

2a To start a cold engine

- 1) Set the stop switch (A) into the START position. If starting a cold engine the choke lever must be moved to the "|\|" position.
- 2) Press the primer bulb 7~10 times, the fuel can be pumped into the carburettor. This will reduce the number of start attempts after a longer break.
- 3) Now stand the hedge trimmer on the ground, place left hand on the front handle. Use your right hand to pull the starter grip (B) quickly.
- 4) Once the engine attempts to run. Move the choke lever to the |\| position.
- 5) Pull the starter grip again until the engine runs, let it run for about 15 seconds then operate this hedge trimmer.

Operating the Hedge Trimmer

Step 2 - Starting the Engine (continued)

! ATTENTION! Don't touch the blade.

2b Starting under warm conditions

- 1) Set the switch (A) to (START).
- 2) Set the choke lever to (|\|).
- 3) Pull the starter grip (B) quickly until engine runs.

Step 4 - Trimming

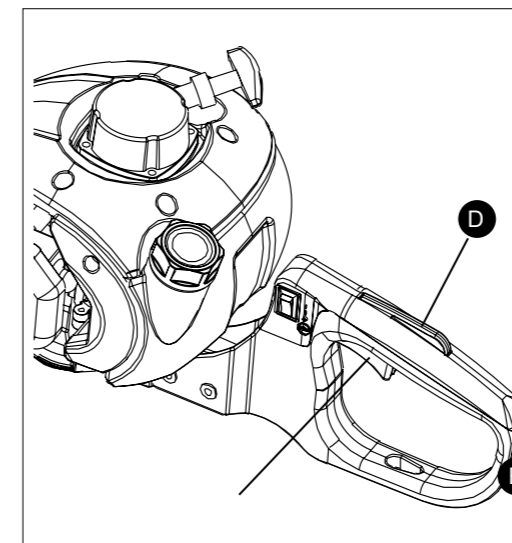

Depress the throttle lever lock (D) and throttle lever (E) to active the blade.

Operating the Hedge Trimmer

Step 4 - Trimming (continued)

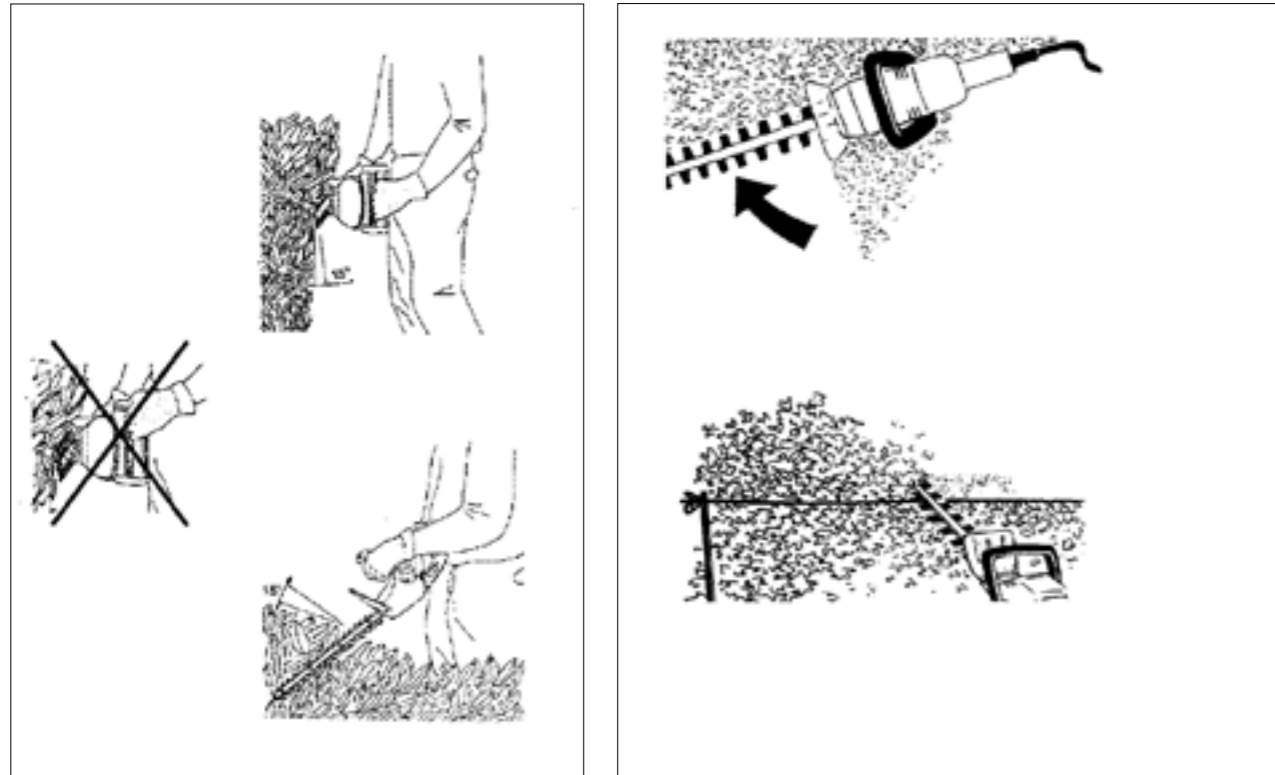

Always start with the sides. Guide the hedge trimmer along an arch route up and down and keep cutting. You should be using both blade sides.

When cutting hold the hedge trimmer at the angle of about 15° and guide it horizontally across the hedge. When cutting the top part guide the trimmer in a sickle like movement toward the hedge edges. Cut branches will then fall on the ground.

- Do not cut hedges out of the main trimming and pruning season.
- If the branches are bigger than 22mm, they must be removed by pruning shears.
- If heavy pruning is required, you should work in stages.

Stopping

Stopping

The hedge trimmer is equipped with an automatic brake system for quick stop which stops the blade immediately once the throttle is released to prevent a possible accident.

If you want to switch off the machine completely, you must move the switch into the "OFF" position.

Cleaning the Air Filter

Cleaning the air filter

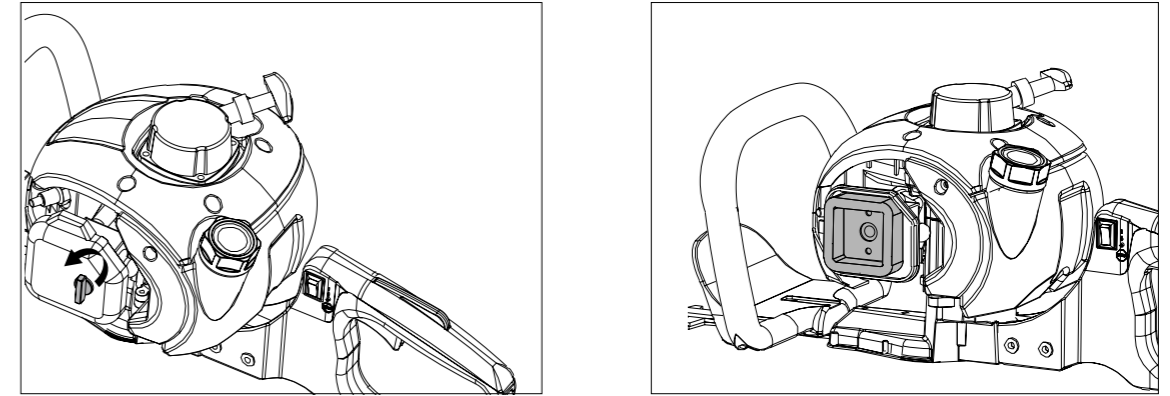

- 1) Loosen the screw from the air filter housing and remove the cap.
- 2) Remove the air filter.
- 3) Wash the air filter in warm water (with a small amount of detergent).
- 4) Rinse the air filter through with clean water.
- 5) Leave the air filter to dry out completely.
- 6) Replace the air filter.
- 7) Replace the cover with the lugs positioned in the notches in the air filter casing.
- 8) Close the lid, and tighten the bolt again by hand.

Replacing the Spark Plug

Replacing the spark plug

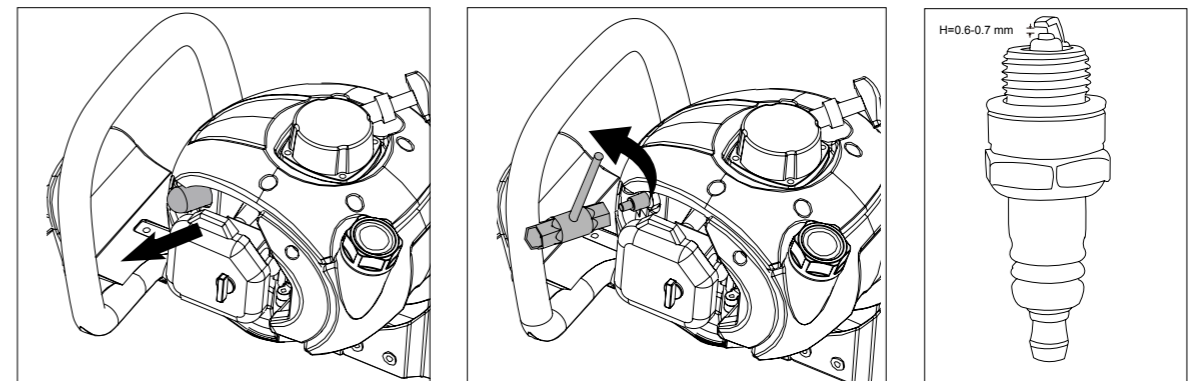

- 1) Pull off the ignition cable plug.
- 2) Use the multifunctional tool to unscrew and remove the spark plug.
- 3) Insert a new spark plug and tighten it carefully with the multifunctional tool.
- 4) Snap the ignition cable plug back on.

Storing the Hedge Trimmer

Step 1 - Storing the Hedge Trimmer for Short Periods

- Drain all fuel from tank into a container approved for petrol. Run engine until it stops. Clean all foreign material from the trimmer. Store it in a well-ventilated place that is out of reach from children.
- Keep away from corrosive agents such as garden chemicals and de-icing salts.
- Abide by all ISO and local regulations for the safe storage and handling of petrol. Excess fuel should be used up in other 2-Stroke engine powered equipment or disposed of at your local recycle centre.
- Remove any coarse dirt.
- Wipe the machine with a soft damp cloth.

Step 2 - Storing the Hedge Trimmer for Extended Periods

- All the above plus: Clean air filter and replace the spark plug with an exact replacement.

Maintenance

Maintenance Schedule

Performing routine maintenance correctly on your hedge trimmer will ensure you get years of trouble free use.

Please keep this manual safe for future reference.

It is recommended that the following maintenance schedule is adhered to. This will ensure the hedge trimmer operated correctly and is safe to use.

	12 hours of use	24 hours of use	36 hours of use
Air filter	clean	clean	replace
Spark plug	check	clean	replace

Blade lubrication

WARNING! Always switch off the head trimmer and remove the spark plug boot before carrying out any maintenance work.

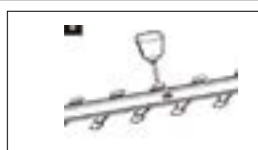

Only clean the machine after it has been switched off. Use only mild soap and a damp cloth to clean it. Never allow fluid to get into the machine. Do not use caustic cleaning products.

Ensure that the blade's cutting edge is always well oiled.

List of consumable Qualcast parts

HS901305	air filter
HS902700	spark plug L8RTF
HS901313	Fuel filter

These parts are available via
www.gardenservicecentre.co.uk

Troubleshooting

General Troubleshooting



CAUTION!

- Always switch off the engine and pull the ignition cable before starting any inspection or adjustment work.
- Remember that the exhaust and other parts will get hot after running the engine, even if only for a few minutes.

The following table provides solutions to common problems encountered with the hedge trimmer.

Fault	Possible Cause	Solution
Engine not starting	<ol style="list-style-type: none"> 1. Empty tank 2. Flooded engine 3. Fouled spark plug (remains of carbon on the electrodes) 4. Electrode gap too large 5. Fouled carburetor or its jets 6. Damaged spark plug connection or damaged spark plug 	<ol style="list-style-type: none"> 1. Fill up 2. Close the throttle, pull cord several times, if required take out the spark plug and dry it 3. Clean the spark plug, check its temperature, replace if needed. 4. Adjust at 0.6-0.7 mm 5. Clean the carburetor with air 6. Replace the spark plug.
Engine runs too fast when idle	<ol style="list-style-type: none"> 1. Cold engine 	<ol style="list-style-type: none"> 1. Warm up slowly; alternatively close the choke a bit.
Engine does not reach its maximum speed	<ol style="list-style-type: none"> 1. Fouled spark plug (remains of carbon on the electrodes) spark gap to large 2. Fouled carburetor or its jets 3. Fouled air filter 4. Exhaust, exhaust channel 5. Sealing ring in crankcase not sealing properly 6. Worn cylinders, pistons and piston rings 7. Wrong fuel mix (too much oil) 8. Bad ignition 	<ol style="list-style-type: none"> 1. Clean the spark plug, check its temperature, replace if needed. Adjust at 0.6-.07 mm. 2. Clean the carburetor with air 3. Clean 4. Take out the exhaust and clean it, remove remains of carbon 5. Replace 6. Replace the cylinder, piston or piston rings, reface the cylinder and piston, assembly 7. Fill up according to the instructions 8. Adjust the ignition coil gap (0.3-0.4 mm)
Engine would not stop	<ol style="list-style-type: none"> 1. The switch was failed. 2. The wiring terminal was disconnected. 	<ol style="list-style-type: none"> 1. Change the switch. 2. Connect up the wiring terminal.

Technical Data

Technical Data Table

Property	Value
Engine type	Single-cylinder, 2-stroke
Displacement(cc)	22.5 cc
Max power /Engine speed	0.55 kW/7000 min ⁻¹
Tank capacity	450 ml
Cutting speed	1550 min ⁻¹
Ignition	C.D.I
Cutting length	550 mm
Fuel ratio (petrol: 2 cycle motor oil)	40:1
Net weight	5 kg
Sound pressure level L _{PA} (dB)	94 dB K=3 dB
Sound power level L _{WA} (dB)	110 dB
Vibration (m/s ²)	7.0 m/s ²
Spark type	L8RTF

Disposal

Disposal Instructions

The hedge trimmer and its accessories are made of various recyclable materials. Dispose of the hedge trimmer in accordance with your local recycling regulations.

Getting Help

Customer Helpline 01904 727503

Our dedicated UK based customer helpline is open 7 days a week to assist you with assembly, parts queries and technical support. We are open during office hours but you can always send an email via support@gardenservicecentre.co.uk. Our experts are here to get you back enjoying your garden in no time.

For useful assembly, starting and maintenance videos and ordering spares please visit www.gardenservicecentre.co.uk.

Calling our service does not affect your statutory rights

UK/Ireland 01904 727503
Monday to Friday 9am – 5pm. Saturday & Sunday 11am – 4pm
www.gardenservicecentre.co.uk
email : support@gardenservicecentre.co.uk

Guarantee

Dear Customer,

In the unlikely event that your device develops a fault, please contact our Customer service department on the telephone number shown below.

1. These guarantee terms cover additional guarantee rights and do not affect your statutory warranty rights.

Claims must be accompanied by Proof of Purchase. This must be in the form of a Sales receipt or Bank statement and must show that the product has been purchased within 1 year prior to the claim, from the retailer that it was originally sold to.

2. Our guarantee covers problems caused by material or manufacturing defects, and will result in the repair of these defects or replacement of the device with a like for like or similar article. Please note that our devices have not been designed for use in commercial, trade or industrial applications. Consequently, the guarantee is invalidated if the equipment is used in commercial, trade or industrial applications or for other equivalent activities.

3. The following are also excluded from our guarantee:

A) Faults due to accidents, customer misuse, or unauthorized repairs

B) Consumable Parts such as Blades/ /Spark plugs or Filters

C) Failure due to lack of routine maintenance

D) Failure as a result of not using the equipment in accordance with the manual and safety instructions

E) The adjustment of cables, drive belts, or recoil starters

4. The guarantee is valid for a period of 2 years starting from the purchase date of the device. Guarantee claims should be submitted before the end of the guarantee period within two weeks of the defect being noticed. No guarantee claims will be accepted after the end of the guarantee period. The original guarantee period remains applicable to the device even if repairs are carried out or parts are replaced. In such cases, the work performed or parts fitted will not result in an extension of the guarantee period, and no new guarantee will become active for the work performed or parts fitted. This also applies when an on-site Service is used.

5. Please keep your sales receipt in a safe place. If the defect is covered by our guarantee your device will either be repaired under the terms of guarantee or we will send you a replacement device. This device may be re-conditioned or Like for like replacement.