

FREEZER >

User Manual

Model Number: UF55W

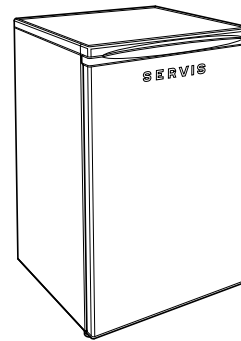

SERVIS
EFFICIENCY BY DESIGN

Visit
servis.co.uk



Contents ›

- 01 Welcome
- 02 Safety Instructions
- 06 Your Freezer
- 08 Electrical Information
- 09 Technical Specification
- 10 Installation
- 12 Usage
- 14 Food Storage Tips
- 17 Cleaning and Care
- 19 Troubleshooting
- 21 Guarantee
- 23 Index

WELCOME >

WELCOME >

Thank you for choosing this Servis Freezer, which has been designed and manufactured to give you many years of trouble-free service.

You may already be familiar with using a similar product but please take time to read these instructions, which have been written to ensure you get the very best from your purchase.

WARRANTY >

Servis provides you with a guarantee which will protect you should your Freezer develop an electrical or mechanical fault during the guarantee period. To ensure that you get a prompt and efficient service, please register your Freezer immediately.

You will find a warranty card included within the packaging. To register, complete the form, or:

- » Visit us at www.servis.co.uk
- » Call us on 0333 577 7232

ITEMS INCLUDED >

Freezer Complete with Drawers

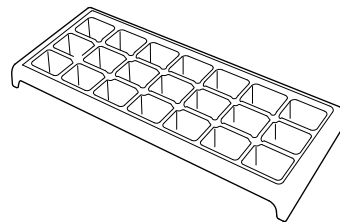
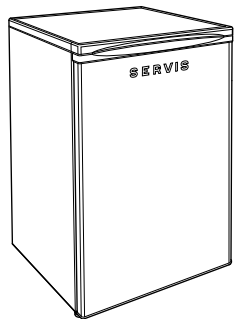

Ice Cube Tray

Figure 1

SAFETY INSTRUCTIONS >

To ensure your safety and the safety of others, please read the following safety precautions before you use your Freezer.

- » Your Freezer conforms to current safety requirements. Inappropriate use can, however, lead to personal injury and damage to property. To avoid the risk of accidents and damage to your Freezer, read this user guide carefully before using it for the first time. It contains important information on the installation, safety, use and maintenance of your Freezer. Retain this user guide for future use and pass it on to any new owners. Read this user guide before using or installing your Freezer.
- » Do not expose your Freezer to moisture or rain.
- » Always remove the mains plug from the wall socket when not in use or before any service operation.
- » Your Freezer is for domestic use only and is only intended for the storage of edible foodstuffs.
- » This appliance can be used by children aged from 8 years and above and persons with reduced physical, sensory or mental capabilities or lack of experience and knowledge if they have been given supervision or instruction concerning use of the appliance in a safe way and understand the hazards involved. Children shall not play with the appliance. Cleaning and user maintenance shall not be made by children without supervision.
- » Before setting up your Freezer, check for any external visible damage. Do not install or use your Freezer if it is damaged.
- » Before connecting your Freezer, ensure that the information on the data plate (voltage and connected load) matches that of the mains electricity supply. If in doubt, consult a qualified electrician.

SAFETY INSTRUCTIONS ›

- » Containers with flammable gases or liquids can leak at low temperatures. Do not store any containers with flammable materials, such as spray cans or fire extinguisher refill cartridges in the vicinity of the Freezer.
- » Do not connect your Freezer to the mains electricity supply using an extension lead.
- » A damaged power cord/plug can cause fire or give you an electric shock. When damaged it must be replaced, this should only be done by qualified personnel.
- » Never remove the plug from the socket by pulling the cord. Always hold the plug.
- » Never touch the power cord/plug with wet hands as this could cause a short circuit or electric shock.
- » Never let the power cord be crushed by the Freezer itself or other heavy objects.
- » Never bend the power cord excessively.
- » Never let the power cord touch or pass over heating appliances.
- » Do not remove items from the Freezer if your hands are damp/wet. This could cause skin abrasions or frost/freezer burns.
- » Do not place fizzy drinks, bottles and cans in the Freezer as they can burst as the contents freeze.
- » Faulty components must only be replaced by a suitably qualified Service Agent using genuine spare parts.
- » Unauthorised repairs could result in unforeseen dangers for the user. Repairs should only be undertaken by an approved service agent.
- » Do not use other electrical appliances inside the Freezer.
- » Do not use mechanical devices or other means to accelerate the defrosting process.
- » Do not refreeze food once it has thawed out.
- » Do not make any alterations to your Freezer, unless authorised to do so by Servis.
- » The packaging of the machine could be hazardous to children. Please refer to the disposal instructions on the rear cover.
- » Please ensure that you have removed all of the packaging materials and protective tape from your Freezer before using.
- » Please take care when moving your Freezer. It is heavy and we recommend that a minimum of two people move it. Your Freezer has a wheel in each back corner. You will find it easiest to move your Freezer when it is tilted backwards and pushed into position.
- » The small quantity of refrigerant used in the Freezer is eco-friendly R600a (an isobutene) and is flammable/explosive if ignited in enclosed conditions. If the cooler elements have been damaged and you suspect a leak, move the Freezer away from any heat sources or open flame and ventilate the room the Freezer is in for a few minutes.
- » Because of the very low temperatures in the Freezer, some foods, such as ice lollies could cause frost burns if consumed immediately after being removed from the Freezer.
- » Keep the ventilation openings of the Freezer clear from obstruction.
- » Do not store medicine or academic research samples that require strict temperature control in the Freezer.

SAFETY INSTRUCTIONS >

- » When cleaning, do not use sharp implements as they may damage the Freezer.
- » Store pre-packed frozen foods in accordance with their instructions and use by date.

Ecological Hints and Tips:

We have provided a few important hints and tips, so that you can save on the cost of energy and help protect the environment.

- » Do not install the Freezer close to sources of heat such as a radiator or a cooker.
- » Install the Freezer in a well ventilated room and keep the openings clear from obstruction.
- » Do not install the Freezer on a wet floor or in a location with high humidity/moisture content.
- » Food which is to be frozen (when cool) should be placed in a fridge before being transferred to the Freezer.
- » Pack all foods into airtight packages before placing them into the Freezer.
- » Ensure there are no obstructions preventing the door from closing properly.
- » Try to avoid keeping the door open for long periods or opening the door too frequently as warm air will enter the cabinet and cause the compressor to switch on unnecessarily often.
- » Clean the condenser on the back of the Freezer at least once a year to make sure it is free from dust and dirt.

YOUR FREEZER >

Environmental Information:

- » Once installation is complete, please dispose of the packaging with due regard to safety and the environment. Disposal instructions can be found on the rear cover.
- » Your Freezer does not contain gases which damage the ozone layer, in either its refrigerant circuit or insulation materials.

FRONT VIEW >

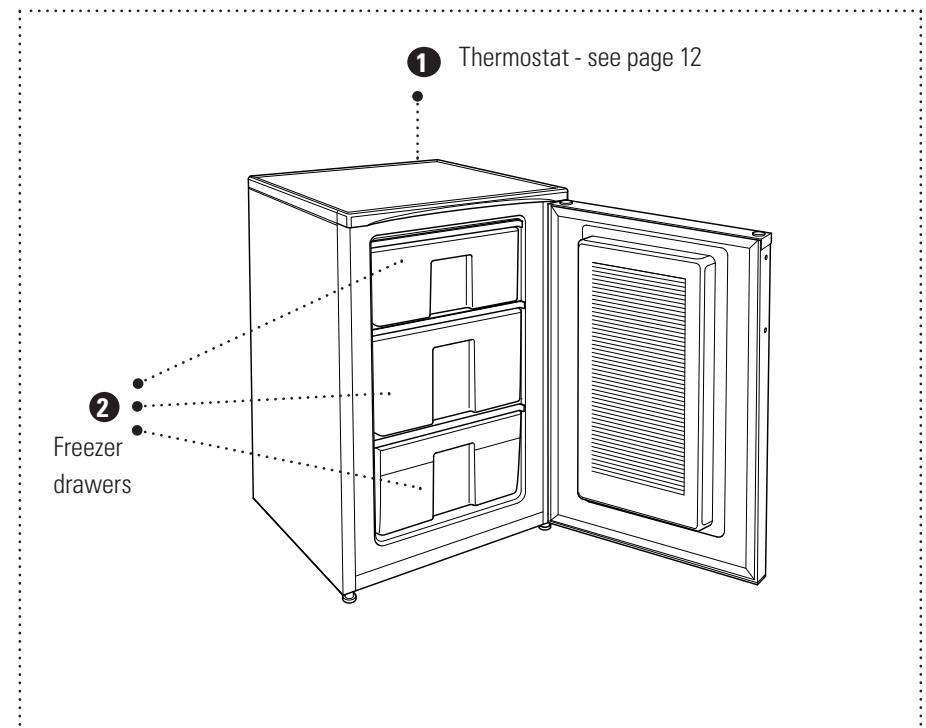
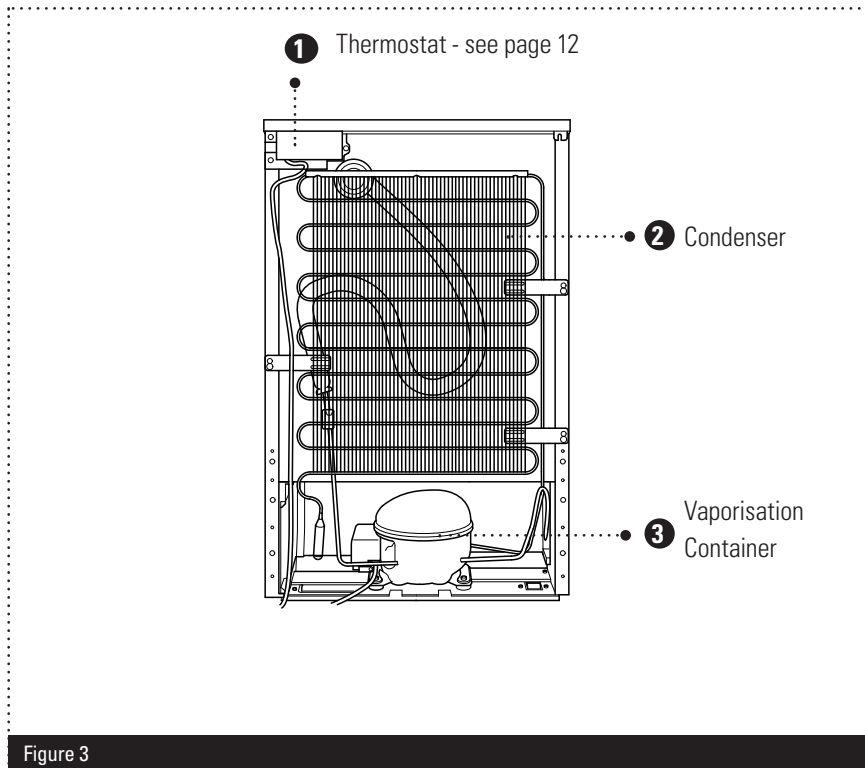

Figure 2

REAR VIEW >



ELECTRICAL INFORMATION >

- » Your Freezer requires a 220-240V, 50Hz mains supply. Do not use any other supply.
- » If your plug requires changing because it is not suitable for your socket, or it is damaged, you should consult a qualified electrician.

Fuse:

- » Replacement fuses should be ASTA-approved to BS1362 and have the correct 13 Amp rating.
- » Replacement fuses can be purchased from an electrical supplier.

TECHNICAL SPECIFICATION >

TECHNICAL SPECIFICATION >

Model Number	UF55W
Power Source	220-240 V AC, 50Hz
Energy Consumption	0.482 KWh/24h
Freezer Rating	4
Climate Class	GT/SN (10°C - 43°C)
Refrigerant Gas	R600a
Gas Capacity	38 gr
Freezer Capacity	75 Lt
Fresh Food Freezing Capacity	7.5 Kg./24h (25°)
Input Power	111 W
Energy Efficiency Rating	A+ Class
Minimum Room Temperature	10°C

INSTALLATION >

INSTALLATION REQUIREMENTS >

Before unpacking and manoeuvring your Freezer, please take the time to read and become familiar with the following points:

- » To avoid risk of injury, please take care when moving your Freezer. It is heavy and we recommend that a minimum of two people move it. Your Freezer has a wheel in each back corner. You will find it easiest to move your Freezer when it is tilted backwards and pushed into position.
- » Make sure that your Freezer can fit through all doorways on route to its final location. The dimensions of your Freezer (including the handles) are 840 mm high x 540 mm wide x 615 mm deep.

Your Freezer should be positioned in a location that meets the following requirements:

- » In a dry room that can be ventilated and out of direct sunlight.
- » Away from any heat source such as a radiator. If this is unavoidable, a suitable heat insulator should be used (this is not supplied).
- » On a suitable floor that will not become damaged, or sag under the weight of the Freezer.
- » At least 500 mm away from stoves, ovens and heater cores and 50 mm away from electrical ovens.
- » At least 20 mm away from another freezer.
- » Insert the distance adjustment plastic blocks into the condenser and turn them 90° to lock them in position. This will prevent the condenser from touching the wall.
- » Do not place anything on top of your Freezer.

INSTALLATION >

ADJUSTING THE FEET >

For safe operation, it is important that your Freezer is stable and balanced. The two adjustable feet at the front are used to level your Freezer. Make sure that your Freezer is level before placing any foodstuffs inside it.

- 1 To increase the height of the Freezer, turn the feet clockwise (Figure 4).
- 2 To decrease the height of the Freezer, turn the feet anti-clockwise (Figure 4).

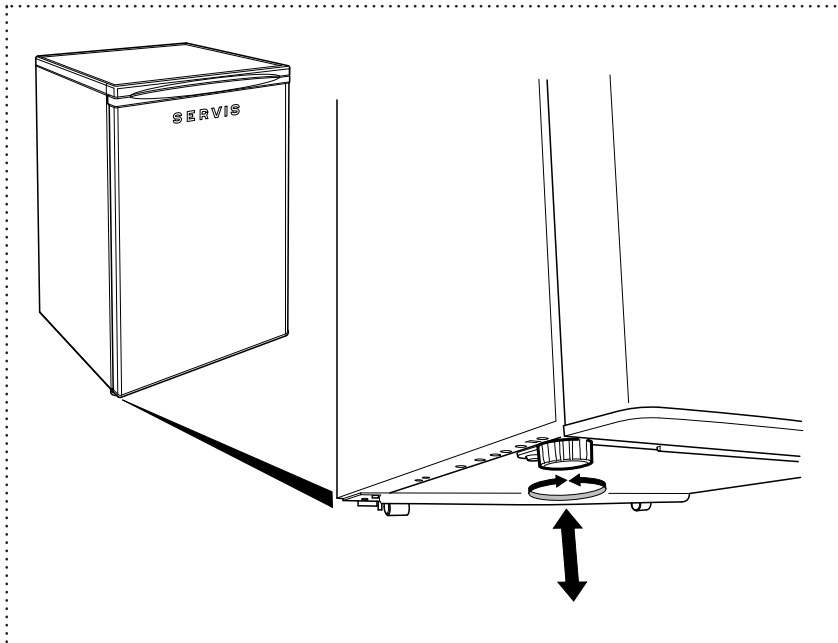

Figure 4

USAGE >

THERMOSTAT >

The thermostat (Figure 5) is used to control the internal temperature of the Freezer. It can be set to any point between • and 3:

- Off.
- 1 Minimum Freeze. For short-term food storage, set the thermostat to between 1 and 2.
 - 2 Medium Freeze. For long-term food storage, set the thermostat to 2.
 - 3 Maximum Freeze. For freezing fresh food quickly, set the thermostat to 3. Once the food is frozen, set the thermostat back to one of the other positions.

Note: The ambient temperature, temperature of food added to the Freezer and the frequency that the door is opened will affect the temperature inside the Freezer. If required, change the temperature setting.

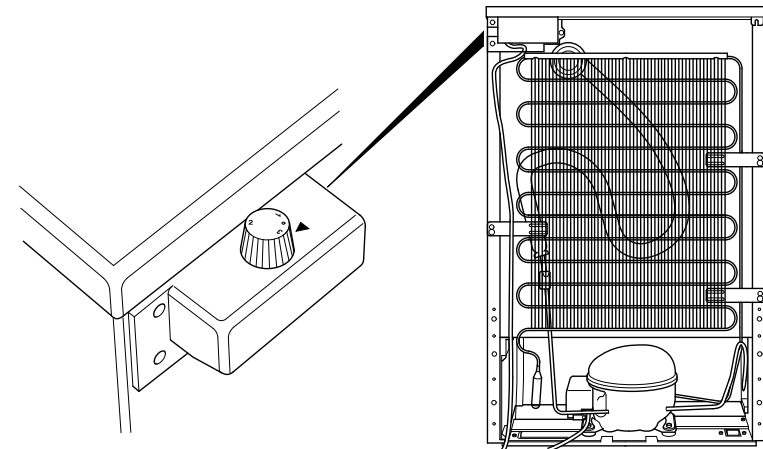

Figure 5

BEFORE USING YOUR FREEZER >

- » When using your Freezer for the first time, or after transportation, keep it in an upright position for at least 3 hours before plugging into the mains. This allows efficient operation and prevents damage to the compressor.
- » We recommend that you wipe all shelving and trays with a cloth soaked in warm water mixed with a teaspoon of sodium bicarbonate before use. After cleaning, rinse with warm water and dry.
- » You may notice a slight odour when using your Freezer for the first time. This is perfectly normal and will fade away once the Freezer starts to cool.
- » Before using your Freezer, make sure that it has been connected to an appropriate mains power supply and is switched on at the socket.
- » When using your Freezer for the first time, switch the Freezer on and operate it for 24 hours without any contents. Do not open the door during this 24 hour period.
- » Your Freezer has a 5 minute built in delay function, designed to prevent damage to the compressor. When power is applied to your Freezer, it will begin to operate normally after 5 minutes.

Freezing Food:

You should use your Freezer for storing food for long periods and making ice. Aim to freeze fresh food as quickly as possible so that it keeps its taste and appearance.

It is important that you do not exceed the maximum freezing capacity of your Freezer, this will help to ensure that your food freezes as quickly as possible. The maximum freezing capacity for freezing within a 24 hour period in an ambient environmental temperature of 25°C is 7.5 kg.

The storage durations of frozen food can be changed by a variety of factors, such as; the frequency of the door opening and closing, thermostat settings, food types and the period of time that elapsed from when the food was acquired to the time it entered the freezer. It is important that you follow the packaging on frozen foods and do not exceed the storage duration. The table below contains some recommendations on freezing.

Food	Preparation	Storage Duration (Months)	Thawing Period at Room Temperature (Hours)
Beef Steak	Cut into single portions	6-10	1-2
Lamb	Cut into single portions	6-8	1-2
Minced Meat	Packed in convenient portions	1-3	2-3
Sausage	Must be packed	1-2	Until Thawed
Chicken and Turkey	Packed in convenient portions	1-2	10-12

FOOD STORAGE TIPS >

Food	Preparation	Storage Duration (Months)	Thawing Period at Room Temperature (Hours)
Freshwater Fish (such as trout)	Cleaned well inside and scaled. Washed and dried. Cut off head and tail where necessary	2	Until Well Thawed
Lean Fish (such as Sea Bass)		4-8	Until Well Thawed
Fatty fish (such as Mackerel)		2-4	Until Well Thawed
Peas	Shelled and washed	12	May Be Used From Frozen
Cauliflower	Remove outer leaves and cut into pieces. Store in container of water with small amount of lemon juice	10-12	May Be Used From Frozen
Green beans, String beans	Washed and cut into small pieces	10-13	May Be Used From Frozen
Mushrooms, Asparagus	Washed and cut into small pieces	6-9	May Be Used From Frozen
Carrot	Washed and cut into slices	12	May Be Used From Frozen
Peppers	Remove stem, cut in half and remove seeds/core	8-10	May Be Used From Frozen

Food	Preparation	Storage Duration (Months)	Thawing Period at Room Temperature (Hours)
Apples, Pears	Peeled and sliced	8-10	Defrost in fridge
Plums, Strawberries, Raspberries, Cherries	Washed and stems removed	8-12	Until Well Thawed
Milk (homogenized)		2-3	Until Well Thawed
Cheese	Sliced and wrapped in plastic foil	6-8	Until Well Thawed
Bread		4-6	2-3
Dough		2-3	1-1.5

WARNING: Do not re-freeze frozen food once it has thawed. It may be a danger to your health.

Ice Cube Trays:

You can make ice cubes using the ice cube trays supplied with your Freezer;

- » Fill each ice cube tray three quarters full with water and place it on the bottom of the freezer compartment.

Power Disruption:

In the event of a power cut, please do not open the door of the Freezer. Your Freezer will preserve your frozen food in an ambient environmental temperature of 25°C for approximately 13 hours. This time period will be shorter if the ambient temperature is higher. When power is re-applied after a power cut your Freezer will not operate for 4-5 minutes. This is to allow the gas in the cooling system to balance and is perfectly normal.

CLEANING AND CARE >

CLEANING AND CARE >

From time to time it will be necessary to carry out cleaning of your Freezer.

- » Before cleaning your Freezer, turn your mains power supply off and remove the plug from the socket.
- » Do not wash your Freezer by pouring water on it.
- » Use a warm, soapy cloth or sponge to wipe the interior and exterior of your Freezer.
- » Carefully remove all drawers by sliding outwards or upwards and clean with soapy water. Do not wash in a washing machine or dish washer.
- » Clean the condenser at the back of your Fridge Freezer at least once a year with a soft brush or vacuum cleaner.
- » Do not use solvents, abrasive cleaners, glass cleaners or all purpose cleaning agents to clean your Freezer. They may damage the plastic surfaces and other components with the chemicals they contain.

This page intentionally blank

TROUBLESHOOTING >

TROUBLESHOOTING INFORMATION >

If your Freezer is not operating as expected, you may find a simple solution listed in the table below.

If your Freezer has developed a fault not covered in this manual, please contact Servis.

Fault	Possible Cause	Solution
Your Freezer does not operate.	It is switched off at the mains.	Check that your Freezer is plugged in and turned on at the mains.
Your Freezer does not get cold enough.	The thermostat is set too low.	Turn the thermostat to a higher value. (A setting of 3 will provide the lowest temperature).
	The door is opened and closed too frequently.	Try to reduce the number of times the doors are opened and closed.
	The door seals are faulty.	Contact Servis.
Food in the Freezer is colder than necessary.	The thermostat setting may be too high.	Put the thermostat on a lower setting.

Fault	Possible Cause	Solution
Your Freezer is noisy.	Your Freezer may not be level.	Adjust the feet to level your Freezer. See page 11.
	Please note that certain noises may be heard from your Freezer during use. They are perfectly normal and are not damaging your Freezer. Contact Servis if you have any concerns.	
There is moisture on the inner parts of your Freezer.	The doors are opened and closed too frequently.	Try to reduce the number of times the doors are opened and closed.
The door does not close properly.	Items of food may prevent them from closing.	Make sure that the doors are free from obstruction.
	The drawers are not correctly in position.	Check that the drawers are properly placed in position.
	The door seal is damaged.	Contact Servis.
	Your Freezer is not level.	Adjust the feet to level your Freezer. See page 11.

GUARANTEE >

DISPOSAL OF YOUR OLD FREEZER >

All packaging and materials used are environmentally friendly and recyclable. Please dispose of any packaging in an environmentally friendly manner. Consult your local council for further details.

- » When the Freezer is to be scrapped, cut off the electrical supply cable and destroy the plug with the remaining cable. Disable the door catch in order to prevent children from becoming trapped inside while playing. A cut off plug inserted into a 13 amp socket is a serious safety (shock) hazard. Please ensure the cut off plug is disposed of safely.



Please refer to the rear cover for disposal instructions.

GUARANTEE >

The Servis guarantee covers the cost of parts/labour/call out charges to repair an appliance should any covered component fail in its normal functions necessitating a repair or replacement to resume those functions.

The Servis guarantee **does not** cover:

- » Accidental damage
- » Use in a commercial environment
- » Incorrect or faulty installation
- » Deliberate damage or neglect
- » Repairs to cosmetic parts

- » Damage caused by foreign objects or substances
- » Claims in respect to routine inspection or maintenance

The Servis guarantee is not transferable.

For your Servis guarantee to be valid, you will need to retain your original purchase receipt and be able to provide it when you make a claim.

The above summary does not include all of the terms and conditions and exclusions which can be found on our website www.servis.co.uk.

KNOW YOUR RIGHTS >

Household contents insurance

Your household insurance may cover you for accidental damage, fire or theft of your product.

Data Protection Act (1988)

Please note that any information provided will be processed by us or our agents in compliance with the provisions of the Data Protection Act 1988, for the purpose of providing cover and handling claims, if any, which may necessitate providing such information to third parties.

INDEX >

A

Adjusting the feet 11

B

Before using your freezer 13

C

Cleaning and care 17

D

Disposal 21

E

Ecological hints and tips 05

Electrical information 08

Environmental information 05

F

Food storage guidance 14

Fuse 08

G

Guarantee 21

I

Installation requirements 10

Items included 01

P

Power disruption 16

S

Safety instructions 02

T

Technical specification 09

Troubleshooting information 19

W

Warranty 01

T: 0333 577 7232
E: info@servis.co.uk

 Visit
servis.co.uk

SERVIS
EFFICIENCY BY DESIGN



The symbol on the product or on its packaging indicates that this product may not be treated as household waste. Instead it shall be handed over to the applicable collection point for the recycling of electrical and electronic equipment. By ensuring this product is disposed of correctly, you will help prevent potential negative consequences for the environment and human health, which could otherwise be caused by inappropriate waste handling of this product. For more detailed information about recycling of this product, please contact your local city office, your household waste disposal service or the shop where you purchased the product.