

**BHC300 30 cm  
Domino ceramic hob**

**INSTRUCTION MANUAL**

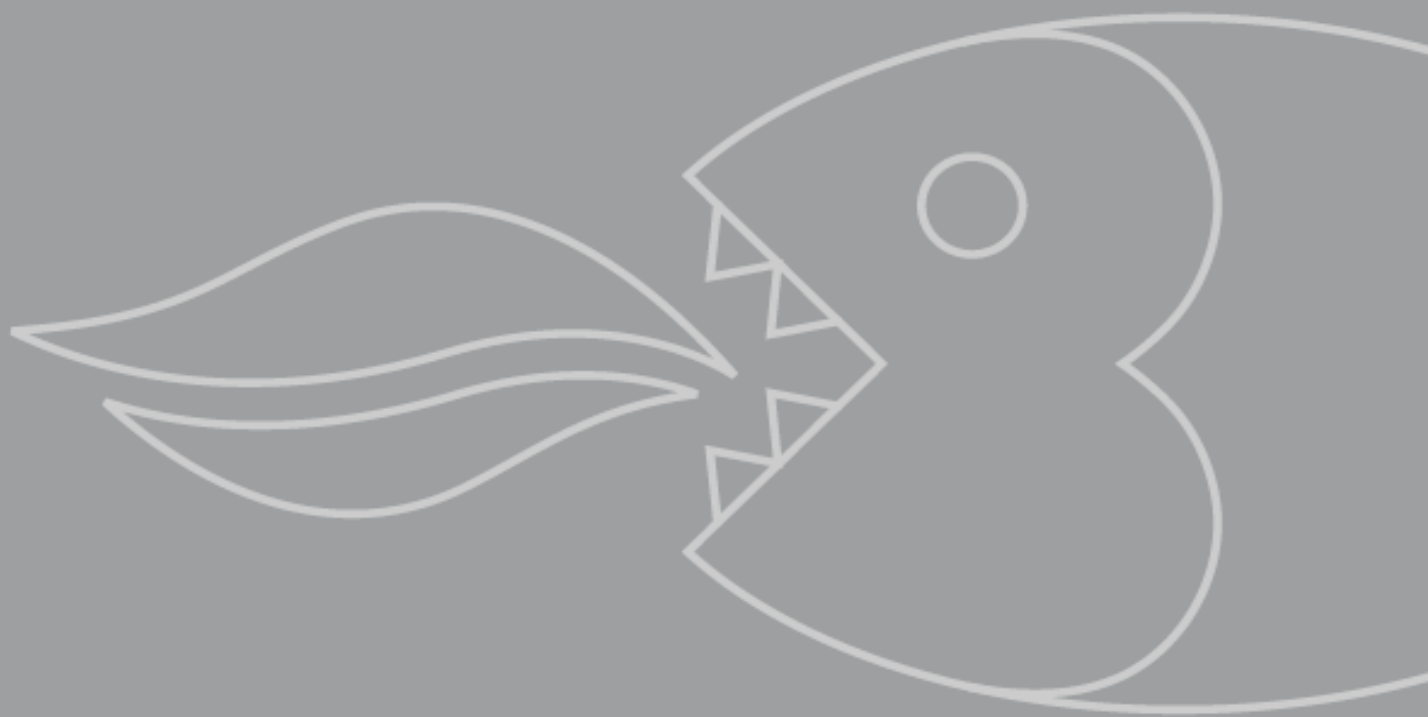

# User Manual for your Baumatic

## BHC300

30 cm Domino ceramic hob with knob control operation

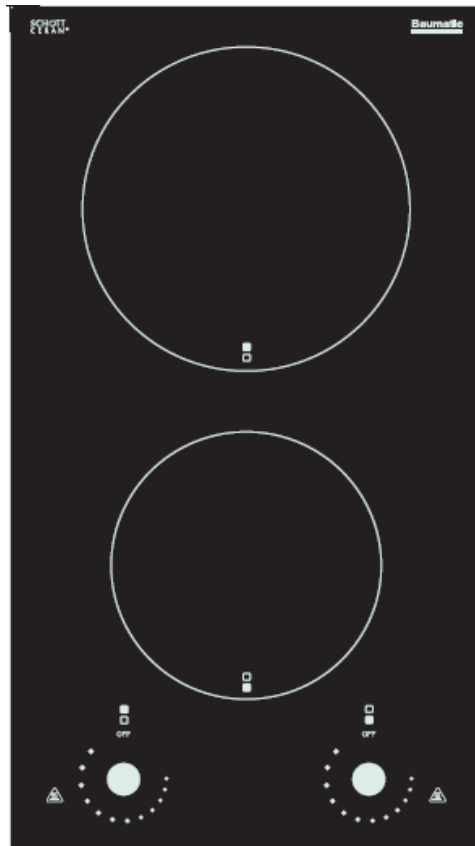

***NOTE:*** This User Instruction Manual contains important information, including safety & installation points, which will enable you to get the most out of your appliance. Please keep it in a safe place so that it is easily available for future reference; for you or any person not familiar with the operation of the appliance.

# Contents

<b>Environmental note</b>	4
<b>Important safety information</b>	5 – 8
<b>Specifications</b>	8 - 10
Product and aperture dimensions	8
Product specifications	8
Standard accessories	9
Electrical details	9
Ceramic hob surface layout	10
<b>Using the ceramic hob</b>	10- 13
Before first use	10
Control knobs	11
Switching on a zone and setting a power level	11
Residual heat indicators	12
Hob guidelines	12 - 13
<b>Cleaning and maintenance</b>	14 - 15
Cleaning the ceramic hob top	14
After each use	14
Cleaning table	14
Using a ceramic hob scraper	15
Using a specialist ceramic hob cleaner	15
<b>Installation</b>	15 - 20
Positioning	16
Unpacking the appliance	16
Installing the appliance	17 – 19
Electrical connection	19 - 20
<b>My appliance isn't working correctly</b>	21 – 22
<b>Baumatic consumables</b>	23
<b>Contact details</b>	24

**This appliance is marked according to the European directive 2002/96/EC on Waste electrical and Electronic Equipment (WEEE). By ensuring this product is disposed of correctly, you will help prevent potential negative consequences for the environment and human health, which could otherwise be caused by inappropriate waste handling of this product.**

The symbol  on the product, or on the documents accompanying the product, indicates that this appliance may not be treated as household waste. Instead it shall be handed over to the applicable collection point for the recycling of electrical and electronic equipment.

**Disposal must be carried out in accordance with local environmental regulations for waste disposal.**

**For more detailed information about treatment, recovery and recycling of this product, please contact your local city office, your household waste disposal service or the shop where you purchased the product.**



- The packaging materials that Baumatic uses are environmentally friendly and can be recycled.
- Please discard all packaging material with due regard for the environment.

## Important safety information



Your safety is of the utmost importance to Baumatic. Please make sure that you read this instruction booklet **before** attempting to install or use the appliance. If you are unsure of any of the information contained in this booklet, please contact the Baumatic Customer Care Department.

### General Information

- This appliance is designed for domestic household use and for the cooking and frying of domestic foodstuffs.
- **IMPORTANT:** *The adjacent furniture and all materials used in the installation **must** be able to withstand a minimum temperature of 85°C above the ambient temperature of the room it is located in, whilst in use.*
- Certain types of vinyl or laminate kitchen furniture are particularly prone to heat damage or discolouration at temperatures below the guidelines given above.
- Any damage caused by the appliance being installed in contravention of this temperature limit, **will be the liability of the owner.**
- Your new appliance is guaranteed against electrical or mechanical defects, subject to certain exclusions that are noted in Baumatic's Conditions Of Guarantee. The foregoing does not affect your statutory rights.
- The use of this appliance for any other purpose or in any other environment without the express agreement of Baumatic Ltd. will invalidate any warranty or liability claim.
- You should not use this appliance to store items on or as a work surface.
- No modifications to the appliance are permitted by Baumatic Ltd.
- You should not store or place flammable or highly flammable liquids/materials on top of or near the appliance. Items made from aluminium, plastic or plastic film should also be kept away from the appliance, as they may fuse to the surface.
- **Repairs may only be carried out by Baumatic service engineers or their authorised service agents.**

## Child Safety

- Baumatic strongly recommend that babies and young children are prevented from being near to the appliance and not allowed to touch the appliance **at any time**. During and after use, all surfaces will be hot.
- If it is necessary for younger family members to be in the kitchen, please ensure that they are kept under close supervision at all times.
- Older children should only be allowed to utilise the appliance when supervised.

## General Safety

- ✓ The appliance should only be installed and connected by a suitably qualified person.
- ✓ Care should be taken to ensure that the units and work surfaces that you build the appliance into, meet with the relevant standards.
- ✓ If you notice any scratches, splits or cracks in the ceramic glass, you should immediately switch off the appliance and disconnect it from your mains supply. Otherwise there is the risk of electric shock occurring.

## During use

- ✓ Any film or stickers that are present on the hob surface when it is delivered should be removed before use.
- ✓ Care should be used when utilising the appliance, otherwise there is a risk of burns being caused.
- You should not allow the electrical connection cables to come into contact with the hob surface when it is hot or any hot cookware.
- If fat and oil overheats, then it can ignite extremely quickly. For this reason, when cooking with fat and oil the appliance should not be left unattended.
- ✓ Make sure that all of the cooking zones are switched off after use.

## Cleaning

- Cleaning of the hob should be carried out on a regular basis.
- **IMPORTANT:** *Before attempting to clean the appliance, it should be disconnected from the mains and cool.*
- Great care should be taken whilst using this appliance and when following the cleaning procedure.
- You should not use a steam jet or any other high pressure cleaning equipment to clean the appliance.

## Installation



***This appliance must be correctly installed by a suitably qualified person, strictly in accordance with the manufacturer's instructions. Please see the specific section of this booklet that refers to installation.***

- ***Baumatic Ltd. declines any responsibility for injury or damage, to person or property, as a result of improper use or installation of this appliance.***

## Declaration of conformity

This appliance complies with the following European Directives:

- 2006/95/CE General regulations / Low tension
- 1935/2004/CE 90/128/EEC This appliance is suitable to come in contact with food
- 2004/108/CE Electromagnetic compatibility
- The manufacturer declares that the hob is built using certified materials and requires the appliance to be installed in accordance with the standards currently in force. This appliance must be used by a trained person for domestic purposes only.

## To avoid damaging your appliance

- The ceramic glass can be damaged by objects falling onto it.
- The ceramic glass edge can be damaged by knocks from cookware.
- Cast iron and cast aluminium cookware with damaged bases may scratch the ceramic surface if they are dragged across it.

- Pans should be lifted on and off the hob surface and not dragged.
- Cooking zones should not be switched on without cookware placed on it. Also the cookware should not be empty.
- Food or liquid that has high sugar content may damage the hob top if it comes into contact with the ceramic hob surface. Any spillages should be wiped up immediately, however this may not prevent the hob surface from becoming damaged.

## Specifications

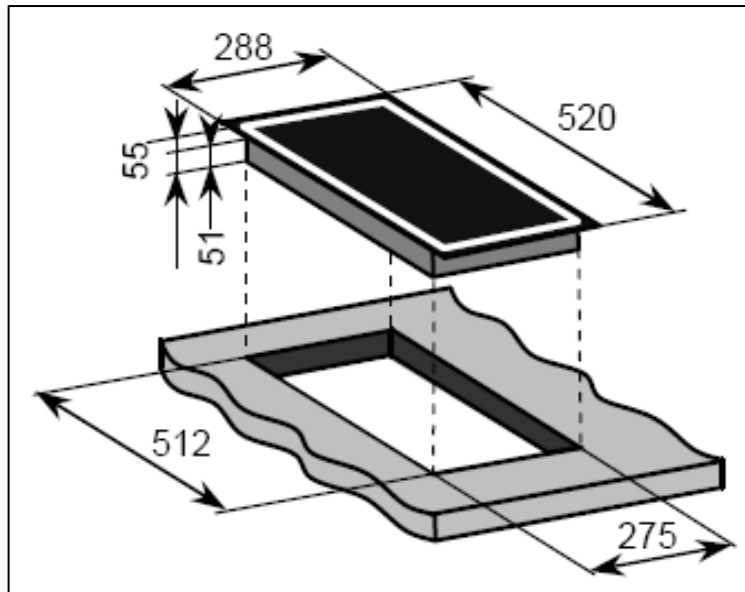

### Product dimensions:

Depth: 520 mm  
 Width: 288 mm  
 Height: 55 mm

### Aperture dimensions:

Depth: 512 mm  
 Width: 275 mm

### Product specifications

- 1 x 1.80 kW hyper-speed zone (Ø 200 mm)
- 1 x 1.20 kW hyper-speed zone (Ø 165 mm)
- Front knob control operation
- 2 residual heat indicators
- Safety lock

### Standard accessories

- Ceramic hob scraper



## Electrical details

<b>Rated Voltage:</b>	220-240, Vac 50-60 Hz
<b>Supply Connection:</b>	20A (double pole switched fused outlet with 3mm contact gap)
<b>Max Rated Inputs:</b>	3.60 kW
<b>Mains Supply Lead:</b>	3 core x 1.5 mm <sup>2</sup> (not supplied)

For future reference please record the following information which can be found on the rating plate and the date of purchase which can be found on your sales invoice. The rating plate of your hob is located on the underneath of the appliance. Therefore it is a good idea to record this information before you install your appliance.

**Model Number** .....

**Serial Number** .....

**Date of Purchase** .....

## Ceramic hob surface layout

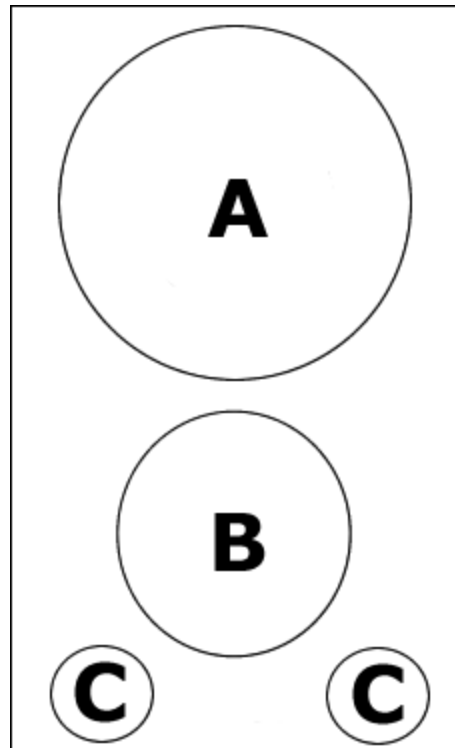

- A = 1.80 kW hyper-speed zone (Ø 200 mm)  
B = 1.20 kW hyper-speed zone (Ø 165 mm)  
C = Control knobs

### Using the ceramic hob

#### Before first use



**IMPORTANT:** You should clean the ceramic hob surface (see "Cleaning and maintenance" section).

- You should switch on one cooking zone at a time, for 5 minutes at the maximum setting. This will help to eliminate any new smell that exists and evaporate any humidity that has formed on the heating elements during transit.
- Do not burn off more than one zone at once.
- **You must** place a saucepan filled half full with cold water on each zone as you burn it off.

## Control knobs

- All operations are performed by means of the 2 control knobs that can be found at the front of the hob top.
- The control knob should be turned clockwise to select a heating level. The markings around the outside of each control knob indicate the power level that you have set the zone to.
- A marking above each control knob, indicates which zone that it controls.

## Switching on a zone and setting a power level

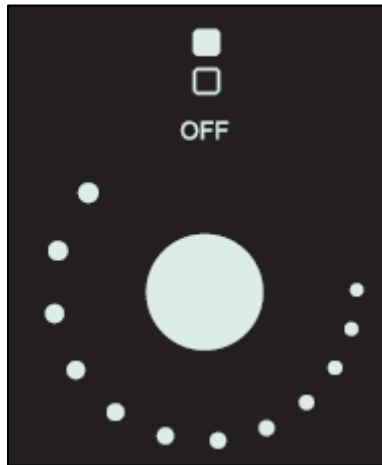

- Turn the control knob anti clockwise of the cooking zone that you wish to cook on.
- Each cooking zone can be adjusted to different power settings. The further anti-clockwise you turn the control knob, the cooler the cooking zone will be.
- When you have finished cooking, make sure that you turn the control knob clockwise, to the OFF position.

## Residual heat indicators

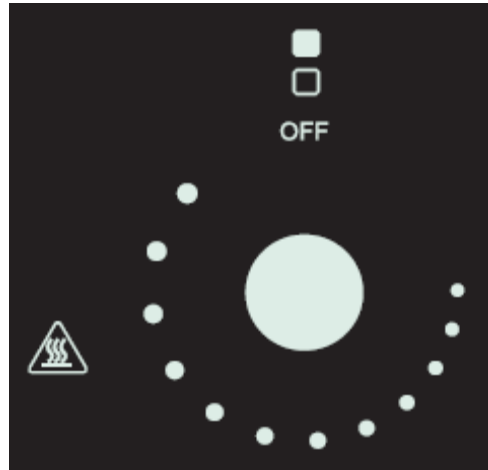

- Next to of each control knob, there is a residual heat indicator.
- After switching a cooking zone on, when the temperature of goes above 60°C the corresponding residual heat indicator neon will come on.
- After switching a cooking zone off, the residual heat indicator neon will stay. This means that the zone has not been switched off for more than 35 minutes since last use. Therefore it is more likely that the temperature of the zone will still be hot enough to cause injury.
- After 35 minutes, from the zone being switched off, the residual heat indicator will turn off.
- **IMPORTANT:** *The residual heat indicator will disappear if your mains supply is cut.*

## Hob guidelines

- The first few times the hob top is used, it may give off an acrid, burning smell. This smell will disappear completely with repeated use.
- The worktop is fitted with cooking areas of different diameter and power.
- The positions where the heat will radiate from are clearly marked on the hob top. The saucepans must be positioned exactly on these zones for efficient heating to occur. Pans should have the same diameter as the cooking zone that they are being used on.

- You should not use saucepans with rough bottoms, as this can scratch the ceramic surface.
- Before use, make sure that the bottoms of the saucepans are clean and dry.
- When cold, the bottom of the pans should be slightly concave, as they expand when hot and lie flat on the surface of the hob. This will allow the heat to transfer more easily.
- The best thickness for the bottom of the pans is 2 – 3 mm of enamelled steel and 4 – 6 mm for stainless steel with sandwich type bottoms.
- If these rules are not followed, then there will be a great loss of heat and energy. Heat not absorbed by the saucepan, will spread to the hob, frame and surrounding cabinets.
- Preferably cover pans with a lid to permit cooking at a lower heat.
- Always cook vegetables and potatoes, etc. in as little water to reduce cooking times.
- Food or liquid that has high sugar content may damage the hob top if it comes into contact with the ceramic hob surface. Any spillages should be wiped up immediately, however this may not prevent the hob surface from becoming damaged.
- ***IMPORTANT: The ceramic hob surface is tough; however it is not unbreakable and can be damaged. Especially if pointed or hard objects are allowed to fall on it with some force.***
- ***DO NOT USE THE HOB IF THE SURFACE BECOMES BROKEN OR CRACKED. YOU SHOULD CONTACT THE CUSTOMER CARE DEPARTMENT IMMEDIATELY.***

## Cleaning and maintenance



***Cleaning operations must only be carried out when the hob is cool.***

***The appliance should be disconnected from your mains supply before commencing any cleaning process.***

### Cleaning the ceramic hob top



Any residues that are left on the hob top surface from cleaning agents **will** damage it. You should remove any residues with warm water mixed with a little washing up liquid.



Abrasive cleaners or sharp objects will damage the hob surface; you should clean it using warm water mixed with a little washing up liquid.



You may find it easier to clean some deposits whilst the hob surface is still warm. However you should take care not to burn yourself if cleaning the hob surface when it is still warm.

### After each use

- Wipe the appliance over with a damp cloth.
- Dry the appliance by rubbing the surface with a clean cloth.

### Cleaning table

<b><i>Type of deposit</i></b>	<b><i>Remove immediately?</i></b>	<b><i>Remove when the appliance has cooled down?</i></b>	<b><i>What should I use to remove the deposit?</i></b>
Sugar or food/liquid containing sugar	Yes	No	Ceramic hob scraper
Tin foil or plastic	Yes	No	Ceramic hob scraper
Fat splashes	No	Yes	Ceramic hob cleaner
Metallic discolouration	No	Yes	Ceramic hob cleaner
Water splashes or water rings	No	Yes	Ceramic hob cleaner

## Using a ceramic hob scraper

Your appliance will be provided with a hob scraper. The following guidelines should also be followed when using the ceramic hob scraper: -

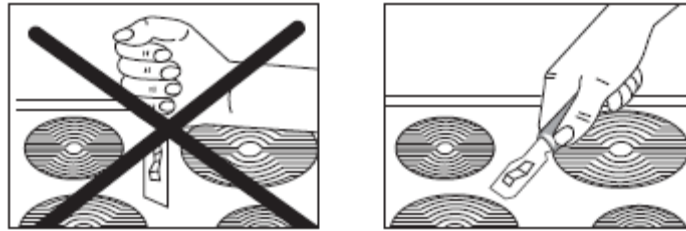

- The scraper should be placed on the ceramic surface at an angle.
- Residues should be removed by sliding the blade carefully over the ceramic surface.
- The ceramic surface should be wiped with a damp cloth that has been placed in warm water mixed with a small amount of washing up liquid.
- Dry the appliance by rubbing the surface with a clean cloth.

## Using a specialist ceramic hob cleaner

It is possible to purchase a specialist ceramic hob cleaner/conditioner.

You should follow the instructions given by the manufacturer of the specialist ceramic hob cleaner. You should ensure that it is suitable for use on your appliance.

## Installation



*The installation must be carried out by a suitably qualified person, in accordance with the current version of the following.*

- ***UK Regulations and Safety Standards or their European Norm Replacements.***
- ***Building Regulations*** (issued by the Department of the Environment).
- ***Building Standards*** (issued by the Scottish Development Department).
- ***IEE Wiring Regulations.***
- ***Electricity At Work Regulations.***

## Positioning



*The adjacent furniture must be able to withstand a minimum temperature rise of 85°C above the ambient temperature of the room it is located in, during periods of use.*

This appliance is classified as Class 3 and therefore is to be built into a kitchen unit (depending on size) or 600 mm worktop that is at least 30 mm thick. The following minimum clearance distances must be observed: -

- 700 mm between the hob surface and the underside of any horizontal surface above it.
- 50 mm clearance around the front, back and sides of the appliance, measured from the cut out.
- If the hob is positioned so that the right or left hand side of the appliance will be near to the edge of a kitchen unit. There must be a gap of at least 150 mm between the side of the hob and the vertical surface of the kitchen unit.

## Unpacking the appliance

When unpacking the appliance please check that the following items are contained within the packaging: -

- 1 Baumatic hob
- 1 Ceramic hob scraper
- 1 Installation and instruction manual
- 1 Baumatic guarantee card
- 4 Fixing brackets
- 4 Fixing screws
- 1 Sealing strip



## Installing the appliance

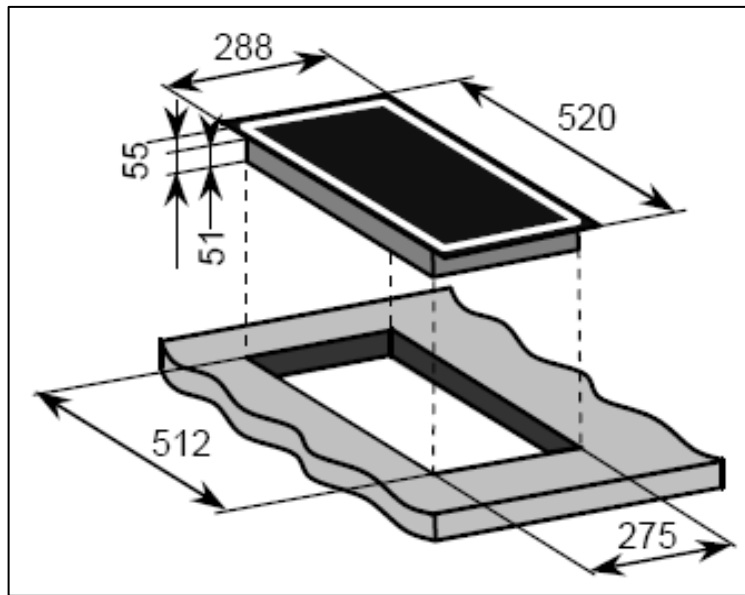

- Cut a hole in the worktop that corresponds with the drawing shown above.

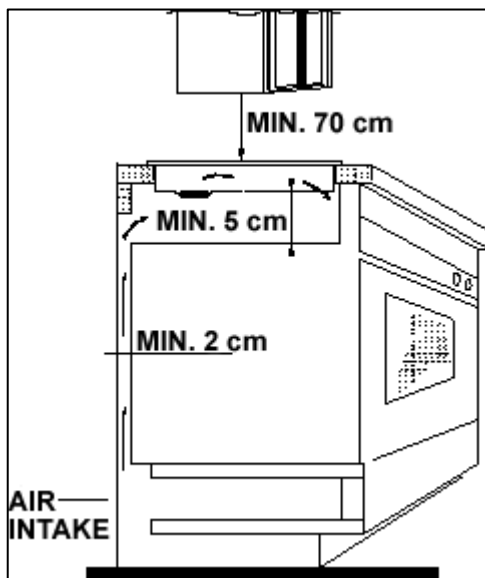

- **IMPORTANT:** You must observe the ventilation requirements shown in the drawing opposite.

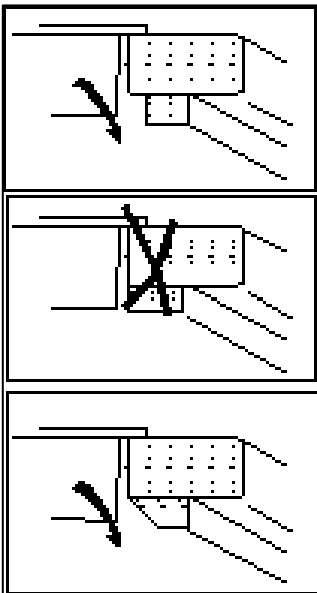
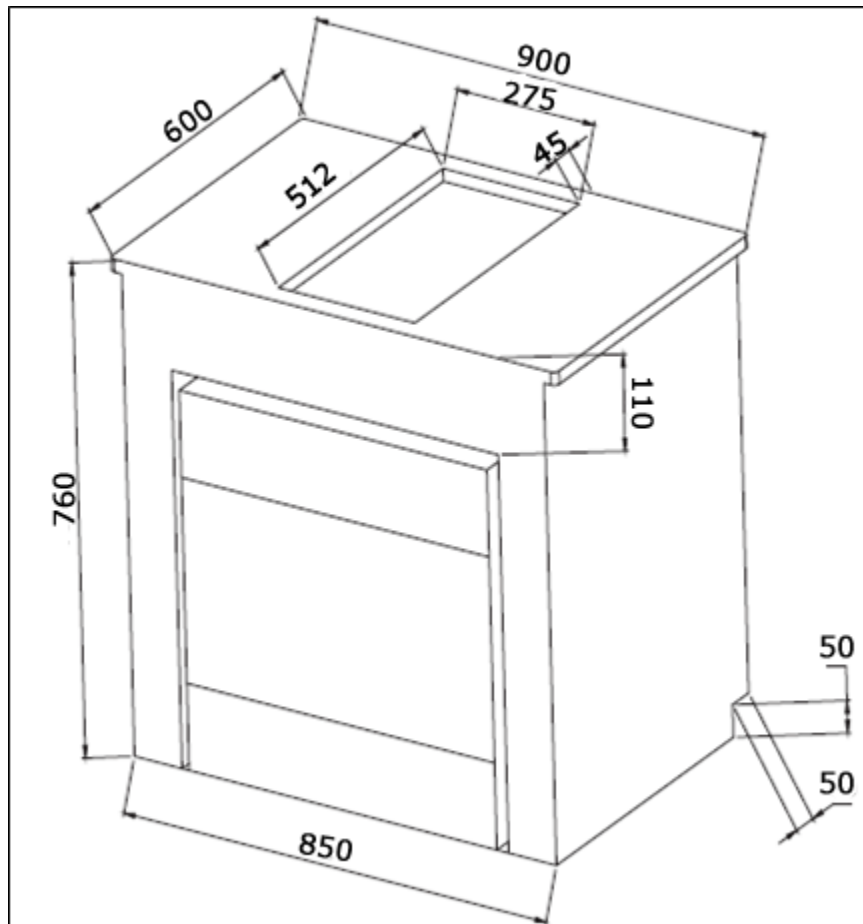

- **IMPORTANT:** There are ventilation holes around the outside of the hob. YOU MUST ensure that these holes are not blocked by the work top, when you put the hob into position (see drawing opposite).

- Carefully turn the hob upside down and place it on a cushioned mat.

- **IMPORTANT:** Do not use a silicon sealant to seal the appliance against the aperture. This will make it difficult to remove the hob from the aperture in future, particularly if it needs to be serviced.

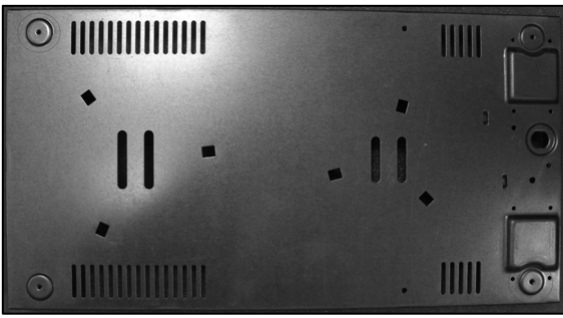

- The supplied brackets need to be fitted to each of the four corners on the underside of the hob.

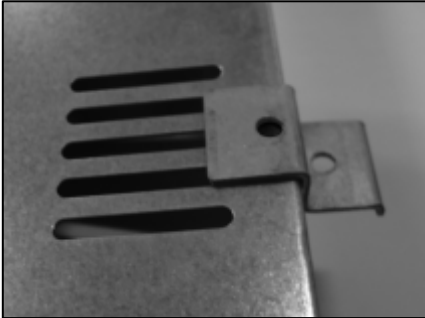

- Place a bracket onto each corner, ensuring that the outer hole lines up with the hole on the corner of the hob.



- Fasten the bracket to the corner of the hob with a screw.

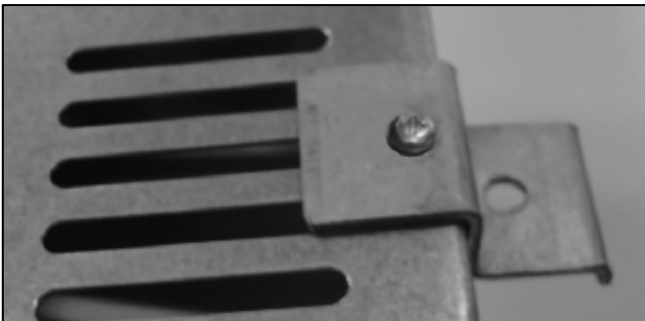

- Place the long screw into the fixing hole on the outer edge of the bracket but do not fully tighten.

- Carefully turn the hob back over and then gently lower it into the aperture hole that you have cut out.



- When the hob is correctly positioned, tighten the long screws to fix the hob securely in the aperture hole. ***These screws MUST be securely tightened.***

## Electrical connection



**YOUR HOB IS INTENDED FOR FITTED AND PERMANENT INSTALLATION.**

- Cable type: H05 RRF 3 core x 1.50 mm<sup>3</sup> (Type RR-F <HAR> marked). *(Not supplied)*
- Before connecting the appliance, make sure that the supply voltage marked on the rating plate corresponds with your mains supply voltage.
- We recommend that the appliance is connected by a qualified electrician, who is a member of the N.I.C.E.I.C. and who will comply with the I.E.E. and local regulations.
- **WARNING: THIS APPLIANCE MUST BE EARTHED.**
- The hob must be wired into a 20A double pole switched fused spur outlet, having 3 mm contact separation and placed in an easily accessible position adjacent to the appliance. The spur outlet must still be accessible even when your hob is located in its housing.
- The wiring in the mains lead is coloured as follows:

<b>Brown</b>	Live
<b>Blue</b>	Neutral
<b>Green and yellow</b>	Earth

- As the colours of the wires in the appliance's mains lead may not correspond with the coloured markings identifying the terminals in your spur box, please proceed as follows:

The **brown wire** must be connected to the terminal marked "L" (live), or coloured **red**.

The **blue wire** must be connected to the terminal marked "N" (neutral), or coloured **black**.

The **green and yellow wire** must be connected to the terminal marked "E" (earth), or by the earth symbol, or coloured **green and yellow**.

- When the connection is completed, no stray strands or cut wire should be present. The cord clamp must be secured over the outer sheath.
- Broken or damaged power leads must only be replaced by a suitably qualified person. A power lead of a similar type must be used in replacement.

### **My appliance isn't working correctly**

- ***The cooking zones are not functioning or will not switch on.***
- \* Check that the mains electrical supply to the appliance is correct and working. Check the mains fuse.
- ***The residual heat indicator has not come on after I have switched a cooking zone off.***
- \* The cooking zone has only been turned on for a short period of time; therefore it did not go above 60°C.
- \* ***IMPORTANT: If the cooking zone does appear to be hotter than 60°C and the residual heat indicator has not come on, you should call the Baumatic Customer Care Department.***
- ***A humming sound is heard when a cooking zone is selected.***
- \* This is normal; the sound will disappear when the zone heats up.
- ***The cooking zones have become discoloured.***
- \* This maybe caused by burnt on remnants of food. This will not affect the working of the appliance. However you should make sure that the cleaning instructions are being followed regularly.



***IMPORTANT: If your appliance appears not to be operating correctly, then you should disconnect it from your mains supply and then contact the Customer Care Department on telephone number (0118) 933 6911.***

***DO NOT ATTEMPT TO REPAIR THE APPLIANCE YOURSELF.***

Please note that if an engineer is asked to attend whilst the product is under guarantee and finds that the problem is not the result of an appliance fault, then you may be liable for the cost of the call out charge.

***The appliance must be accessible for the engineer to perform any necessary repair. If your appliance is installed in such a way that an engineer is concerned that damage will be caused to the appliance or your kitchen, then he will not complete a repair.***

***This includes situations where appliances have been tiled in, sealed in with sealant, have wooden obstructions placed in front of the appliance, like plinths. Or any installation other than the one specified by Baumatic Ltd. has been completed.***

Please refer to the conditions of guarantee that appear on the warranty card that you receive with the appliance.

***IMPORTANT: Baumatic Ltd. operates a policy of continuous improvement and reserves the right to adjust and modify its products without prior notification.***

## Baumatic Consumables

- **BC001** Degreaser for Dishwashers (200 g)
- **BC002** Descaler for Washing Machines and Dishwashers (200 g)
- **BC003** Ceramic Hob Cleaner (250 ml)
- **BC004** Oven Cleaner (250 ml)
- **BC005** Stainless Steel Cleaner and Protector (250 ml)
- **BC007** E-Cloth – General Purpose Cloth
- **BC008** Microwave Cover

To order a Baumatic consumable product please call 0123 5437 244 and quote the product code. You can also order online from [eshop.baumatic.co.uk](http://eshop.baumatic.co.uk)



***United Kingdom***

Baumatic Ltd.,  
Baumatic Buildings,  
6 Bennet Road,  
Reading, Berkshire  
RG2 0QX  
United Kingdom

**Sales Telephone**

(0118) 933 6900

**Sales Fax**

(0118) 931 0035

**Customer Care Telephone**

(0118) 933 6911

**Customer Care Fax**

(0118) 986 9124

**Spares Telephone**

(01235) 437244

**Advice Line Telephone**

(0118) 933 6933

**E-mail:**

sales@baumatic.co.uk  
customercare@baumatic.co.uk  
spares@baumatic.co.uk  
technical@baumatic.co.uk

**Website:**

[www.baumatic.co.uk](http://www.baumatic.co.uk)

**Facebook:**

[www.facebook.com/baumatic.uk](http://www.facebook.com/baumatic.uk)

***Republic of Ireland***

**Service Telephone**

1-890 812 724

**Spares Telephone**

091 756 771

***Czech Republic***

Baumatic CR spol s.r.o.  
Lípová 665  
460 01 Liberec 4  
Czech Republic

+420 483 577 200

[www.baumatic.cz](http://www.baumatic.cz)

***Slovakia***

Baumatic Slovakia, s.r.o.  
Panenská 34  
811 03 Bratislava - Staré Mesto  
Slovakia

+421 255 640 618

[www.baumatic.sk](http://www.baumatic.sk)

***Germany***

Baumatic Gmbh  
Bachstr.10-12  
D-32 257 Bünde  
Deutschland

+49 (0) 5223 99408 0

[www.baumatic.de](http://www.baumatic.de)

***Italy***

Baumatic Italia S.R.L.  
Via Galvani N.3  
35011 Campodarsego (PD)

+3904 9920 2297

[www.baumatic.it](http://www.baumatic.it)

***Holland***

Baumatic Benelux B.V.  
Dukdalfweg 15d  
1332 BH ALMERE  
Nederland

+31(0)36 549 1553

[www.baumatic.nl](http://www.baumatic.nl)









