

Malibu - Desk

Assembly Instructions - Please keep for future reference

274/6616

247/3848

278/5220

278/6652

268/6965

238/3615

275/3922

275/6297

278/6009

280/0332

247/7167

246/4950

246/5818

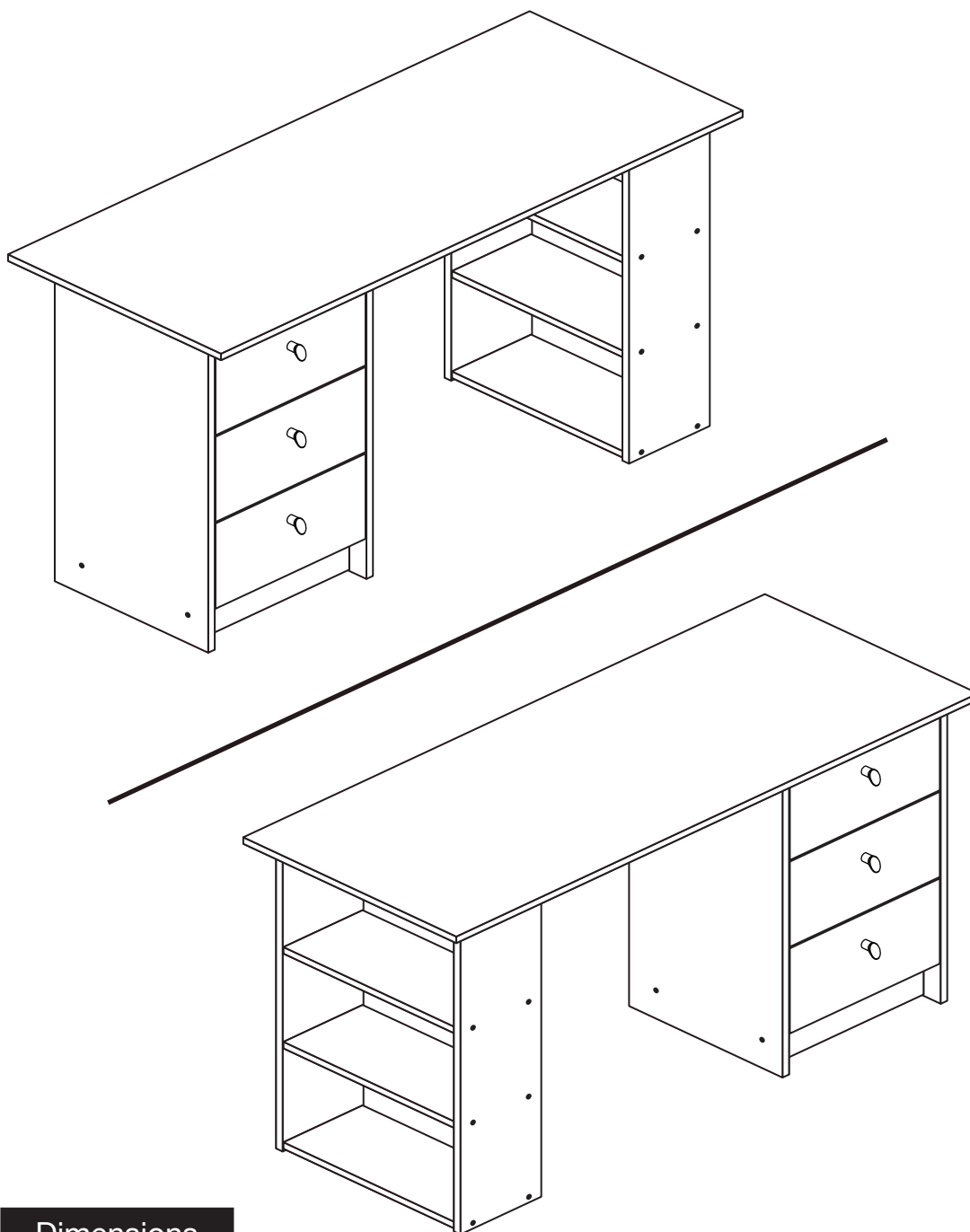

Dimensions

Width - 120cm

Depth - 49cm

Height - 72cm



**MADE IN
BRITAIN**

Important - Please read these instructions fully before starting assembly

If you need help or have damaged or missing parts, call the **Customer Helpline: 08456 400800**



Safety and Care Advice

Important - Please read these instructions fully before starting assembly

- **Warning:** This unit weighs approximately 24kgs. Please lift with care.

- Check you have all the components and tools listed on pages 2 and 3.

- Remove all fittings from the plastic bags and separate them into their groups.

- Keep children and animals away from the work area, small parts could choke if swallowed.

- Make sure you have enough space to layout the parts before starting.

- Do not stand or put weight on the product, this could cause damage.

- Assemble the item as close to its final position (in the same room) as possible.

- Assemble on a soft level surface to avoid damaging the unit or your floor (use opened out unit carton).



- We do not recommend the use of power drill/drivers **for inserting screws**, as this could damage the unit. Only use hand screwdrivers.

- **Safety note:** If there is any chance of this unit being pulled over by children etc. it is recommended that the unit is secured to a wall using suitable fixings (not supplied).

- Dispose of all packaging carefully and responsibly.

Care and maintenance

- Only clean using a damp cloth and mild detergent, do not use bleach or abrasive cleaners.

- From time to time check that there are no loose screws on this unit.

- This product should not be discarded with household waste. Take to your local authority waste disposal centre.

Note: If required the next page can be cut out and used as reference throughout the assembly. Keep this page with these instructions for future reference.

Components - Panels

If you have damaged or missing components, call the **Customer Helpline: 08456 400800** quoting the reference numbers below

Please check you have all the panels listed below

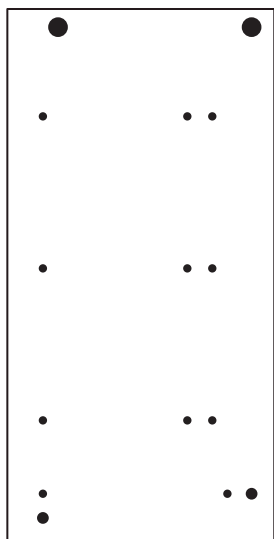

1 Left Side (D2785A)
(706 x 353mm)

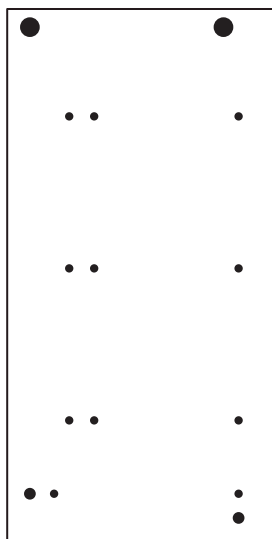

2 Right Side (D2786A)
(706 x 353mm)



3 Bookcase End (D2787A)
(706 x 186mm) x 2

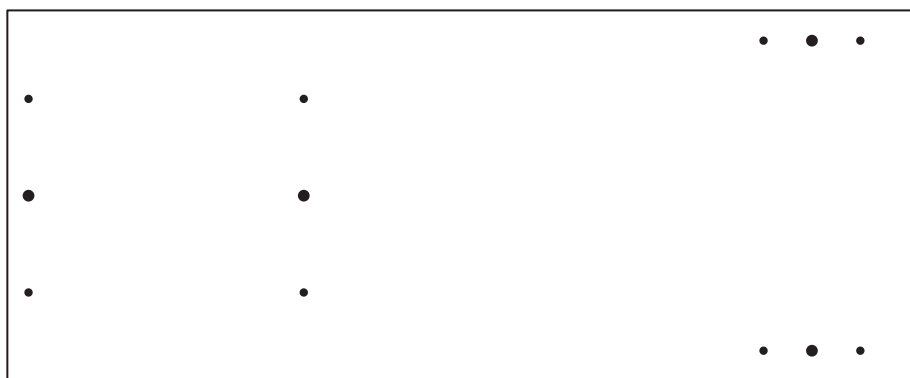

4 Top (D2784A)
(1200 x 490mm)



5 Shelf (D2788A)
(394 x 182mm) x 3



6 Plinth (D2789A)
(349 x 92mm)

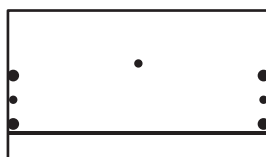

8 Drawer Front (D2791A)
(345 x 196mm) x 3

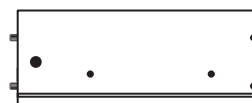

9 Left Drawer Side (W320-124LH)
(320 x 124mm) x 3



7 Rail (D2790A)
(349 x 80mm)

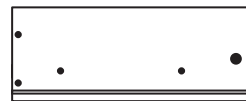

10 Right Drawer Side (W320-124RH)
(320 x 124mm) x 3

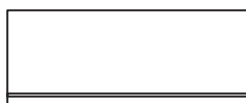

11 Drawer Back (W317-124)
(317 x 124mm) x 3

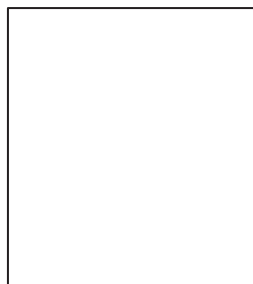

12 Drawer Base (T328-317)
(328 x 317mm) x 3

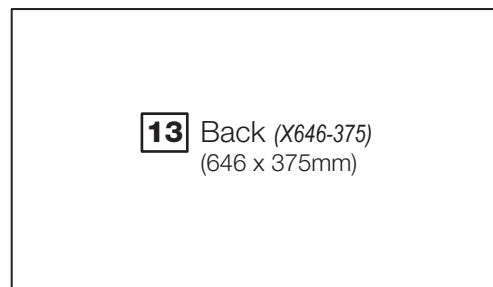

13 Back (X646-375)
(646 x 375mm)











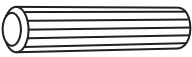
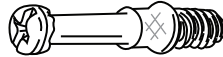
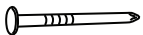



Components - Fittings

If you have damaged or missing components, call the **Customer Helpline: 08456 400800** quoting the reference numbers below

Please check you have all the fittings listed below

Note: The quantities below are the correct amount to complete the assembly. In some cases more fittings may be supplied than are required.

<p>A </p> <p>Wooden dowel (F22) x 8</p>	<p>B </p> <p>Metal dowel (F901) x 14</p>	<p>C </p> <p>Nail (F51) x 11</p>
<p>D </p> <p>Handle (F631) x 3</p>	<p>E </p> <p>Large locking nut (F900) x 8</p>	<p>F </p> <p>Small locking nut (F3) x 6</p>
<p>G </p> <p>40mm Screw (F910) x 16</p>	<p>H </p> <p>25mm Screw (F50) x 3</p>	<p>I </p> <p>Plastic Nail (F91) x 8</p>
<p>J </p> <p>Drawer runner (F1004) x 6</p>		<p>K </p> <p>9mm Screw (F73) x 12</p>
<p>L </p> <p>9mm Screw (F74) x 6</p>	<p>M </p> <p>Wedgefix (F639) x 6</p>	<p>N </p> <p>Knock-in Peg (F171GY) x 12</p>

Tools required

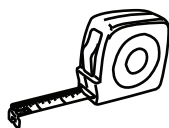

Rule



Cross-head screwdriver



Scissors



Hammer



Eye protection
(when using a hammer or drill)

Ruler - Use this ruler to help correctly identify the screws

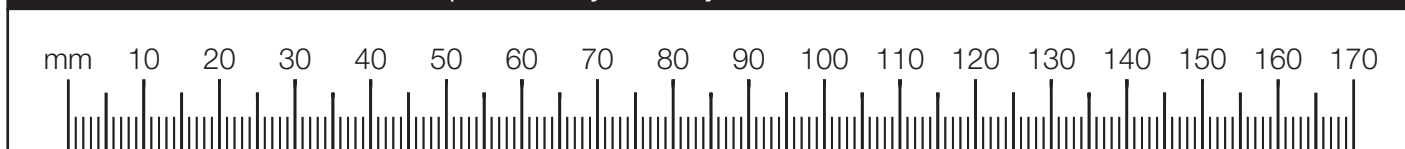

Assembly Instructions

If you have damaged or missing components, call the
Customer Helpline: 08456 400800 quoting the reference
numbers below

Step 1

Prepare the 3 drawer fronts

Screw 2 metal dowels **B** into each of the drawer fronts **8**.

Note: Tighten the metal dowels up fully against the panels.

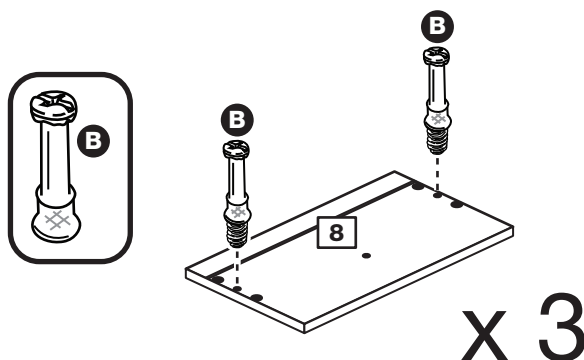

Step 2

Prepare the drawer sides

Insert a small locking nut **F** into the hole shown on the left drawer side **9** and the right drawer side **10**.

Note: The arrow on the locking nut **must** point towards the hole in the edge of the panel.

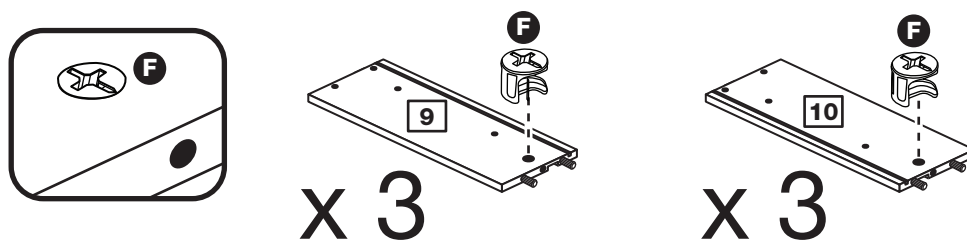

Step 3

Attach the drawer sides to the drawer fronts

Push the left drawer sides **9** and right drawer sides **10** onto the back of the drawer fronts **8**.

Turn the small locking nuts **F** on the left drawer side **9** and right drawer side **10**.

Note: Turn the locking nuts **F** clockwise to secure panels - more than 1/2 a turn.

Note: The locking nuts can be on either surface of the drawer sides. Make sure that the small groove is on the inside, as shown.

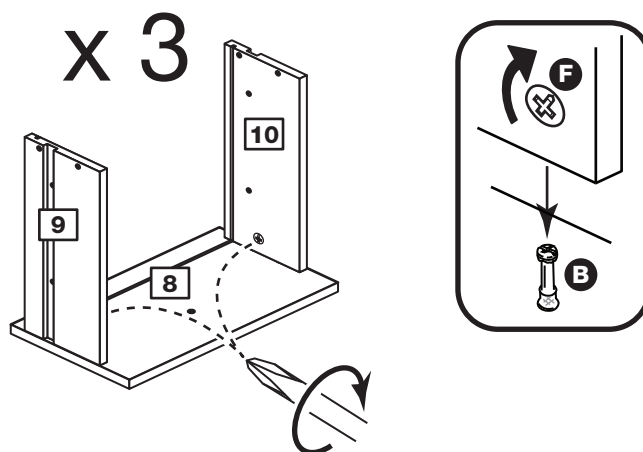

Assembly Instructions

Step 4

Fit the drawer base

Slide the drawer base **12** down the grooves in the drawer sides **9** and **10** and down into the groove in the drawer front **8**.

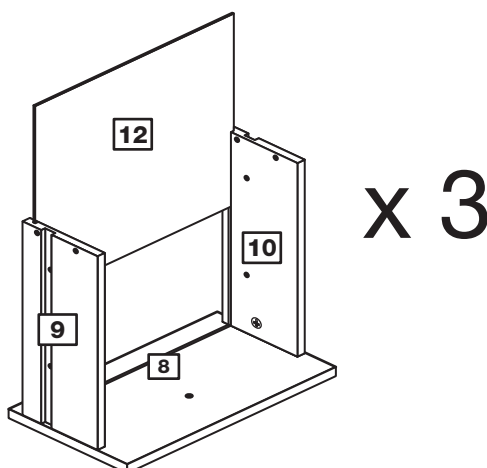

Step 5

Fit the drawer back

Fit the drawer back **11** between the drawer sides **9** and **10**. Make sure that the drawer base **12** fits into the groove in the drawer back **11**.

Hold the drawer back **11** in position and tap the knock-in pegs **N** through the holes in the drawer sides **9** and **10**.

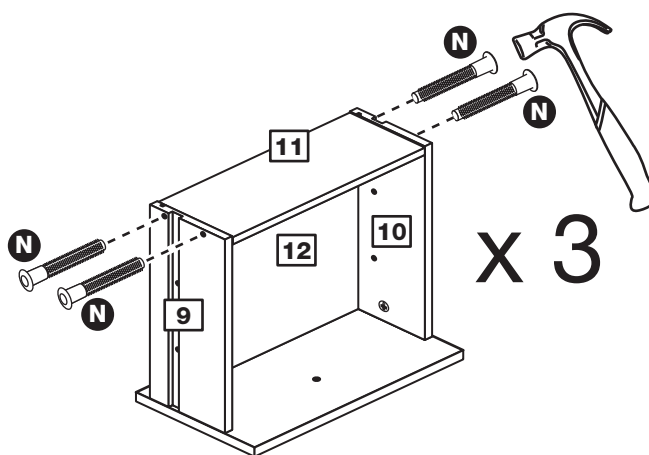

Step 6

Attach the handles

Attach a handle **D** to each of the drawer fronts **8** using screw **H**.

Note: Do not overtighten the screw.

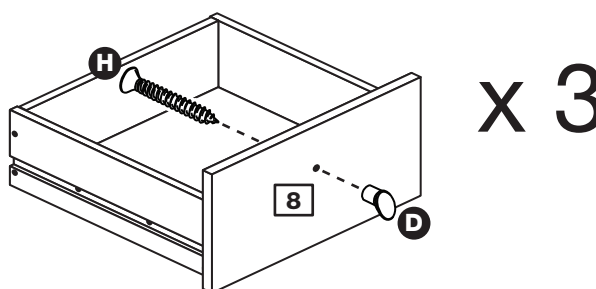

Step 7

Fit the wedgifixes

Turn the drawer assemblies over and slide 2 wedgifixes **M** into the front and back grooves, as shown, and tighten up the screws.

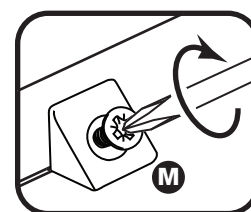
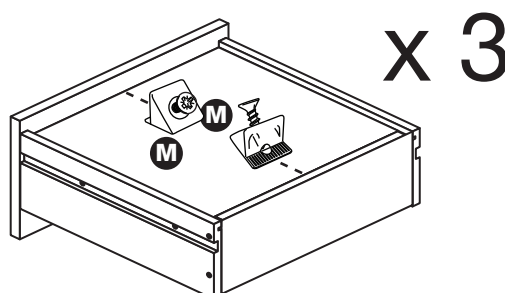

Assembly Instructions

Step 8

Prepare the left side

a: Place 3 runners **J** on the left side **1** as shown. Slide back the top of runner and use the 2nd hole from the front to fit the 1st screw **K**.

b: Slide the runner **J** back the other way and fit the 2nd screw **K** into the corresponding hole in the left side **1**.

Insert 2 large locking nuts **E** into the left side **1**.

Note: The arrow on the locking nuts **must** point towards the hole in the edge of the panel.

Tap a wooden dowel **A** into the left side **1**.

Note: Wooden dowels **must not** stick out from the edge by more than 10mm or they may damage other panels.

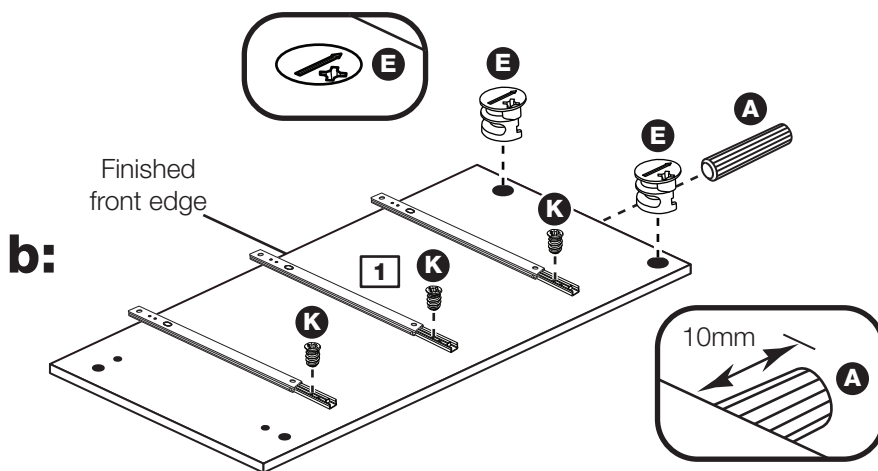
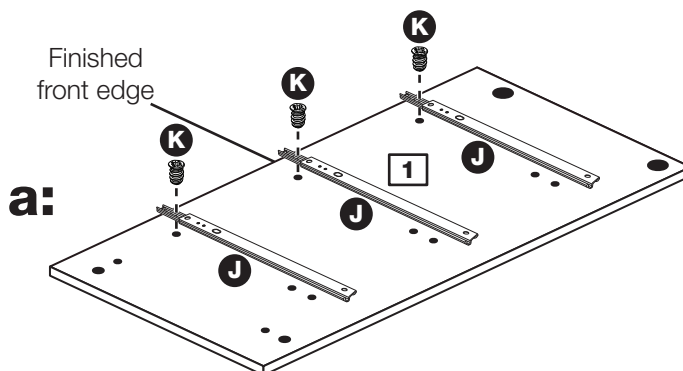
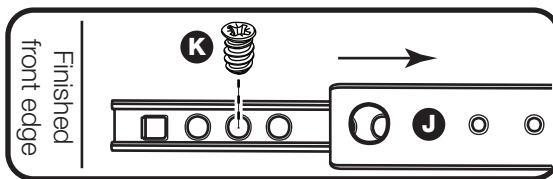

Assembly Instructions

Step 9

Prepare the right side

a: Place 3 runners **J** on the right side **2** as shown. Slide back the top of runner and use the 2nd hole from the front to fit the 1st screw **K**.

b: Slide the runner **J** back the other way and fit the 2nd screw **K** into the corresponding hole in the right side **2**.

Insert 2 large locking nuts **E** into the right side **2**.

Note: The arrow on the locking nuts **must** point towards the hole in the edge of the panel.

Tap a wooden dowel **A** into the right side **2**.

Note: Wooden dowels **must not** stick out from the edge by more than 10mm or they may damage other panels.

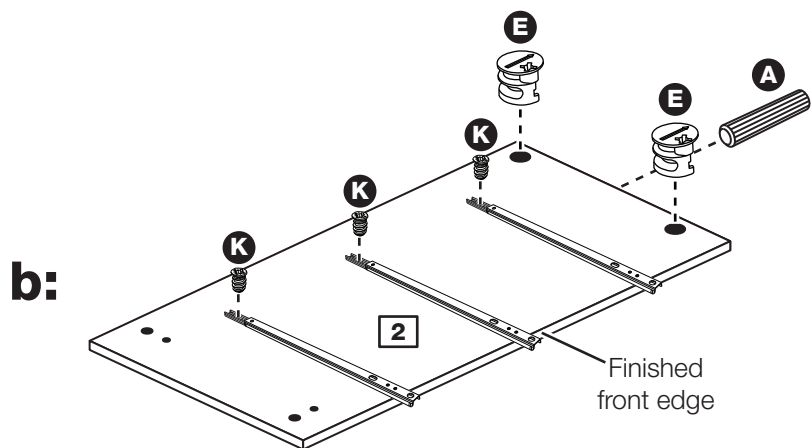
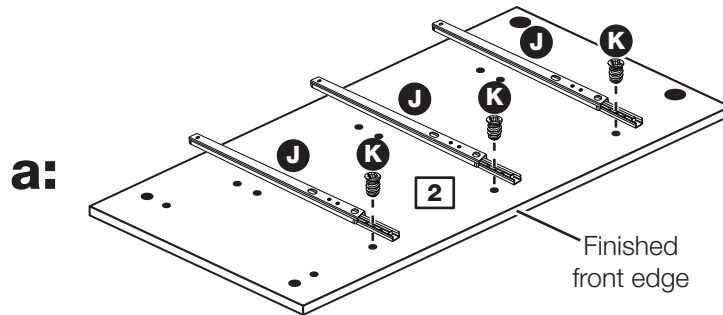
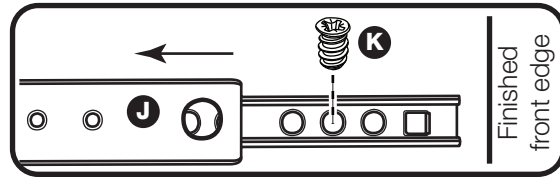

Step 10

Prepare the plinth and the rail

Tap 2 wooden dowels **A** into the plinth **6**.

Tap 2 wooden dowels **A** into the rail **7**.

Note: The plinth will be finished with the main unit colour on one surface.

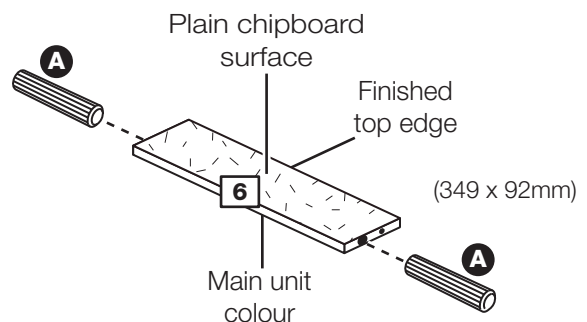

Note: The rail may be plain chipboard or its colour may differ from the main unit colour.

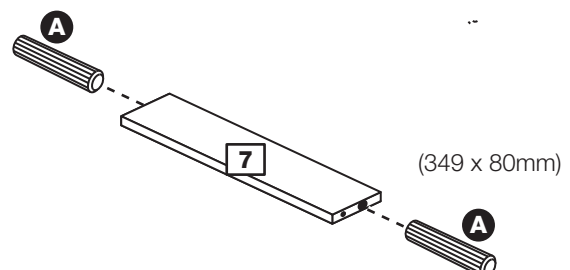

Assembly Instructions

Step 11

Fit the plinth and the rail to the right side

Push the plinth **6** onto the right side **2** and secure it with screw **G**.

Push the rail **7** onto the right side **2** and secure it with screw **G**.

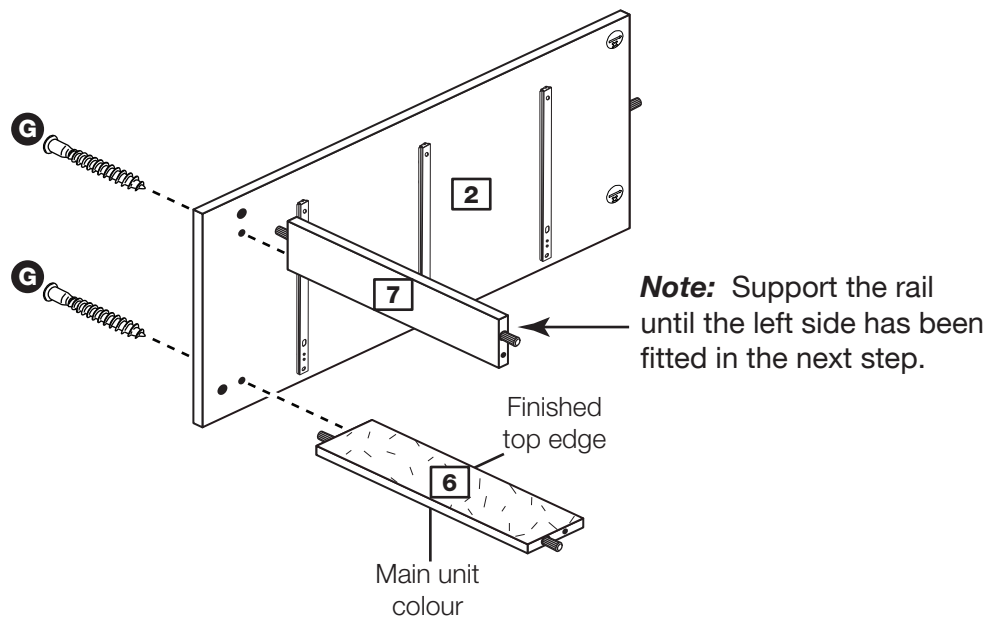

Step 12

Fit the left side

Push the left side **1** onto the unit and secure it with 2 screws **G**.

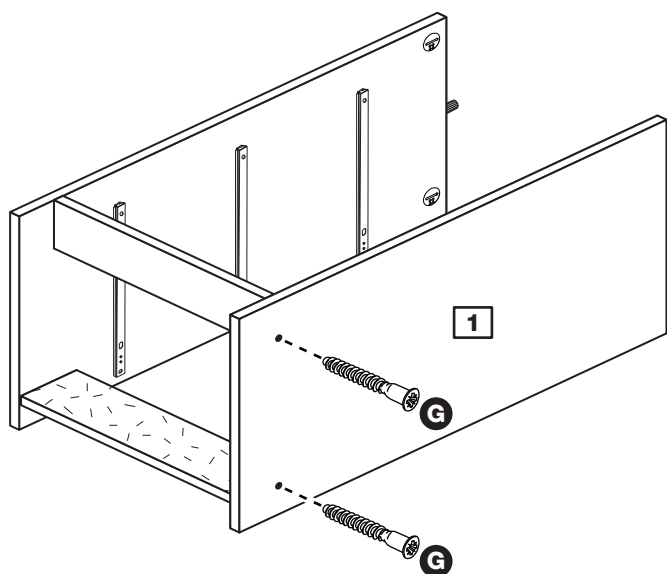

Step 13

Fit 4 plastic nails

Tap 2 plastic nails **I** into the bottom edge of each side **1** and **2** as shown.

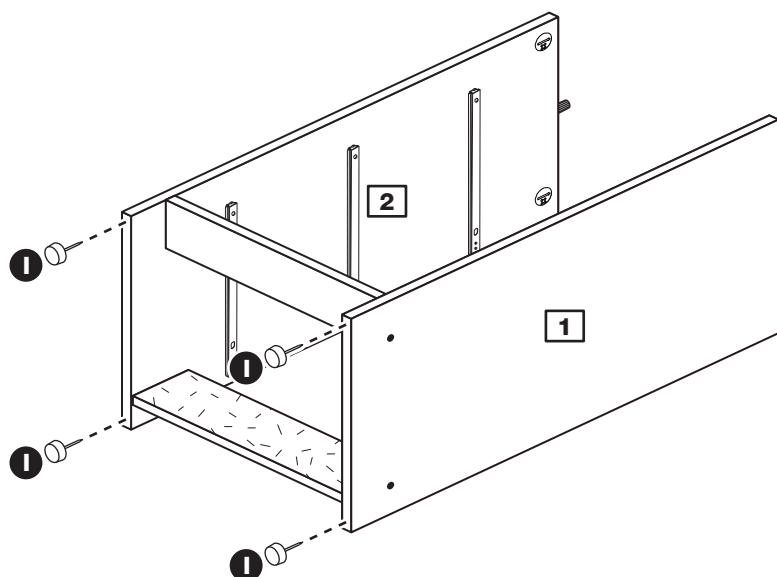

Assembly Instructions

Step 14

Fit the back

a: Square up the unit by making sure that measurement **x to x** equals **y to y**.

b: Place the back **13** down onto the unit, making sure that it is flush with the bottom of the rail **7**.

Nail **C** down the sides and along the bottom edge of the back **13**.

Note: Nails should be spaced about 150mm apart.

a: The measurement from top corner X to bottom corner X must be equal to the measurement from top corner Y to bottom corner Y

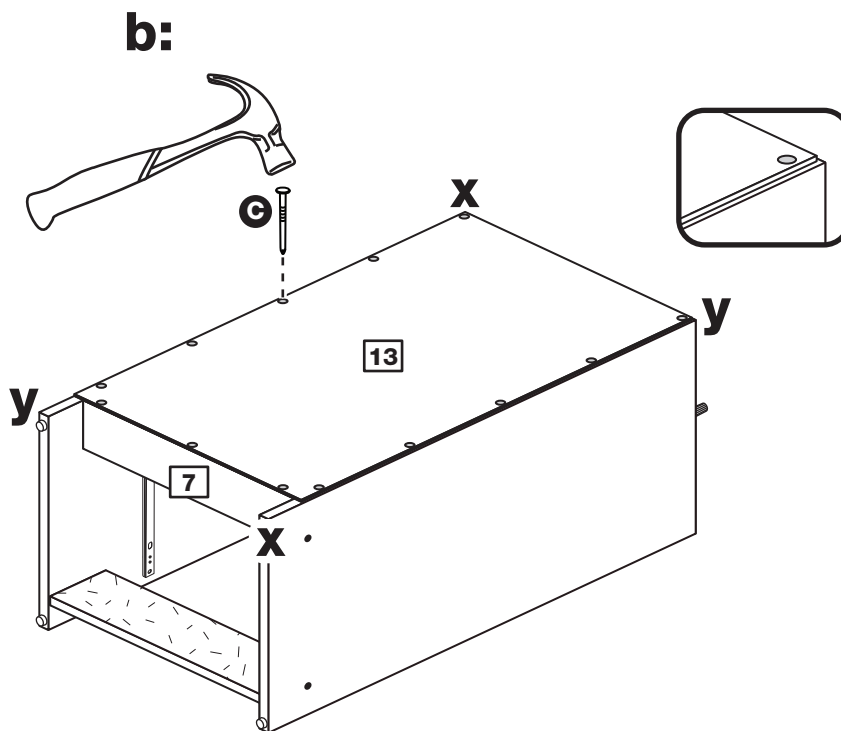

Step 15

Prepare the 2 bookcase ends

Insert 2 large locking nuts **E** into each bookcase end **3**.

Tap a wooden dowel **A** into each bookcase end **3**.

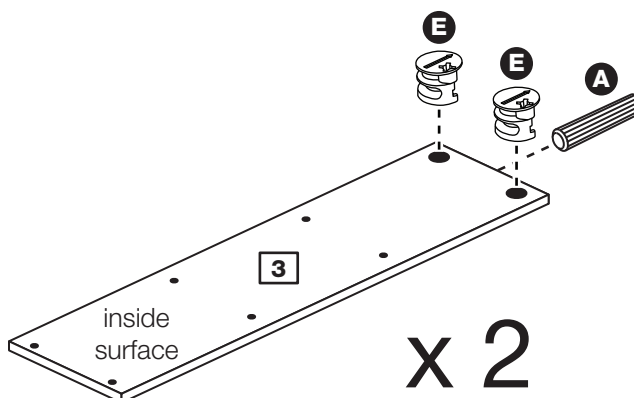

Assembly Instructions

Step 16

Fit the shelves to the bookcase ends

Attach the 3 shelves **5** to the bookcase ends **3** using 12 screws **G**.

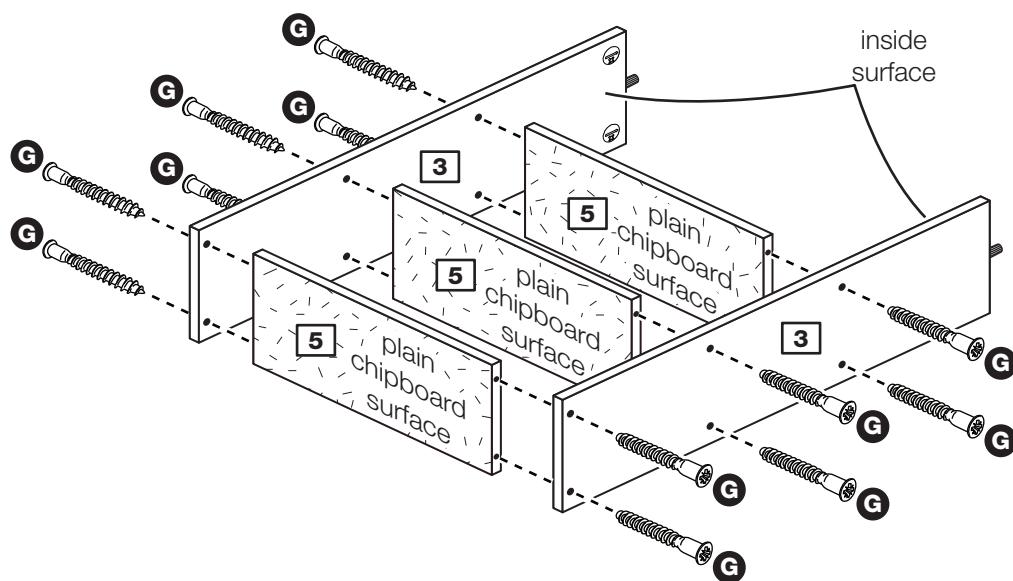

Step 17

Fit 4 plastic nails

Tap 2 plastic nails **I** into the bottom edge of each bookcase end **3** as shown.

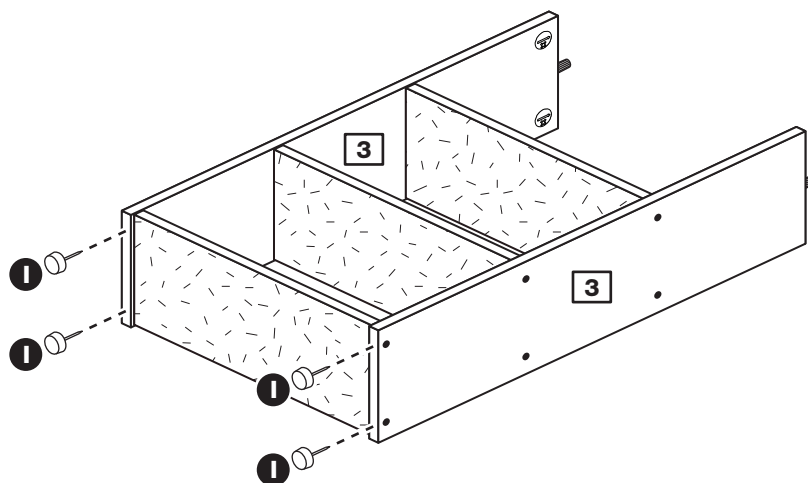

Assembly Instructions

Step 18

Choose desk layout

Before going onto the next step, decide which way around you would like your desk to be.

Place the 2 assemblies where the desk will be used, so that the unit does not have to be moved once the top panel has been secured into place.

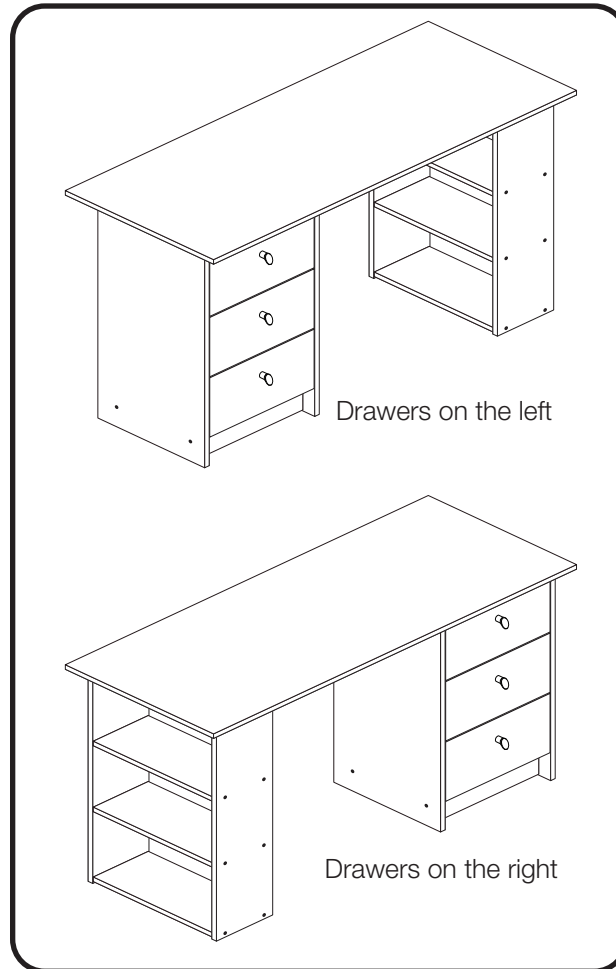

Step 19

Prepare the top

Screw 8 metal dowels **B** into the top **4**.

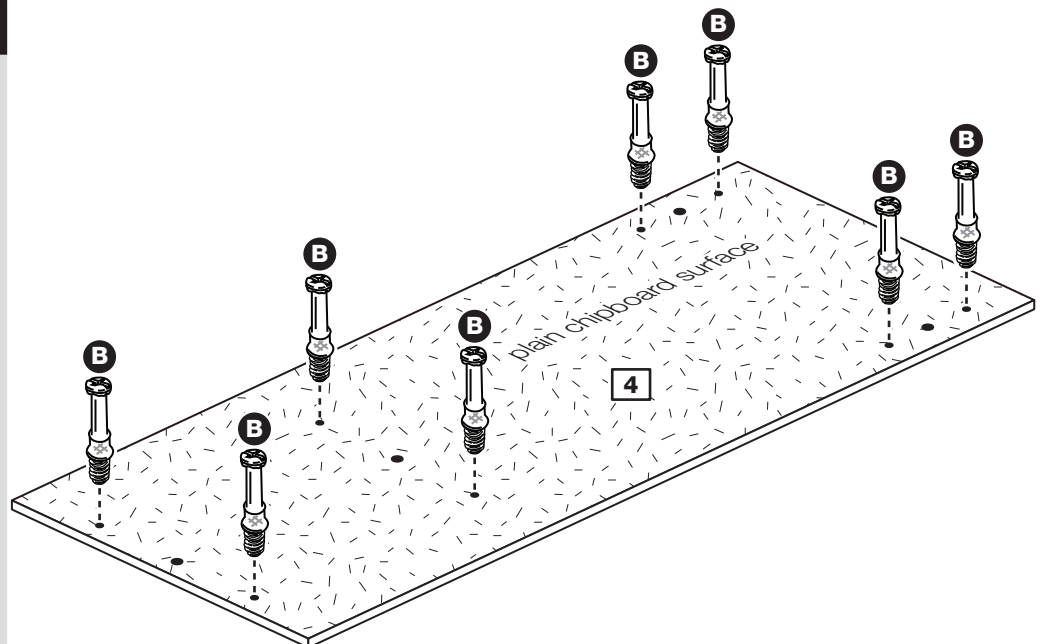

Assembly Instructions

Step 20

Fit the top

Lift the top **4** and push the 8 metal dowels **B** fitted to the top **4** down into the holes in the top edge of the sides and bookcase ends **1**, **2** and **3**.

Use a screwdriver to tighten the 8 large locking nuts **E** fitted to the sides and bookcase end panels **1**, **2** and **3**.

Note: Turn the large locking nuts **E** as far as they will go - more than 1/2 a turn.

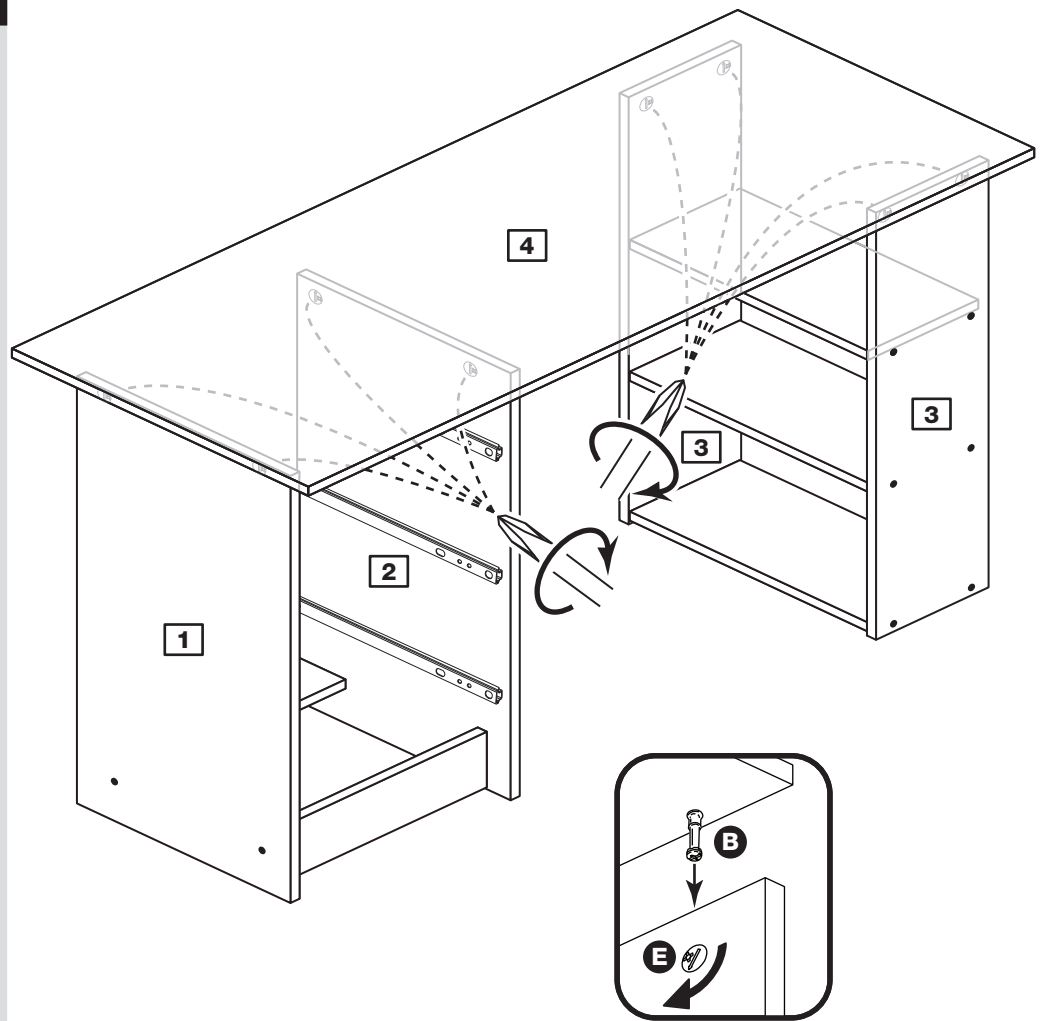

Assembly Instructions

Step 21

Fit the drawers

Starting with the bottom drawer, slide both the runners **J** forward and locate the drawer sides **9** and **10** between them, lining up the holes in the drawer wrap with the 2nd 'threaded' holes in the runners **J**.

Working from the inside of the drawer, insert 2 screws **L** through the drawer sides and out into the 2nd threaded hole in the runner.

Assembly is complete



Warning: The unit is heavy. Lift with care.

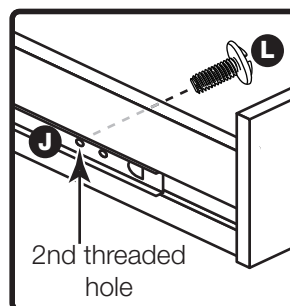
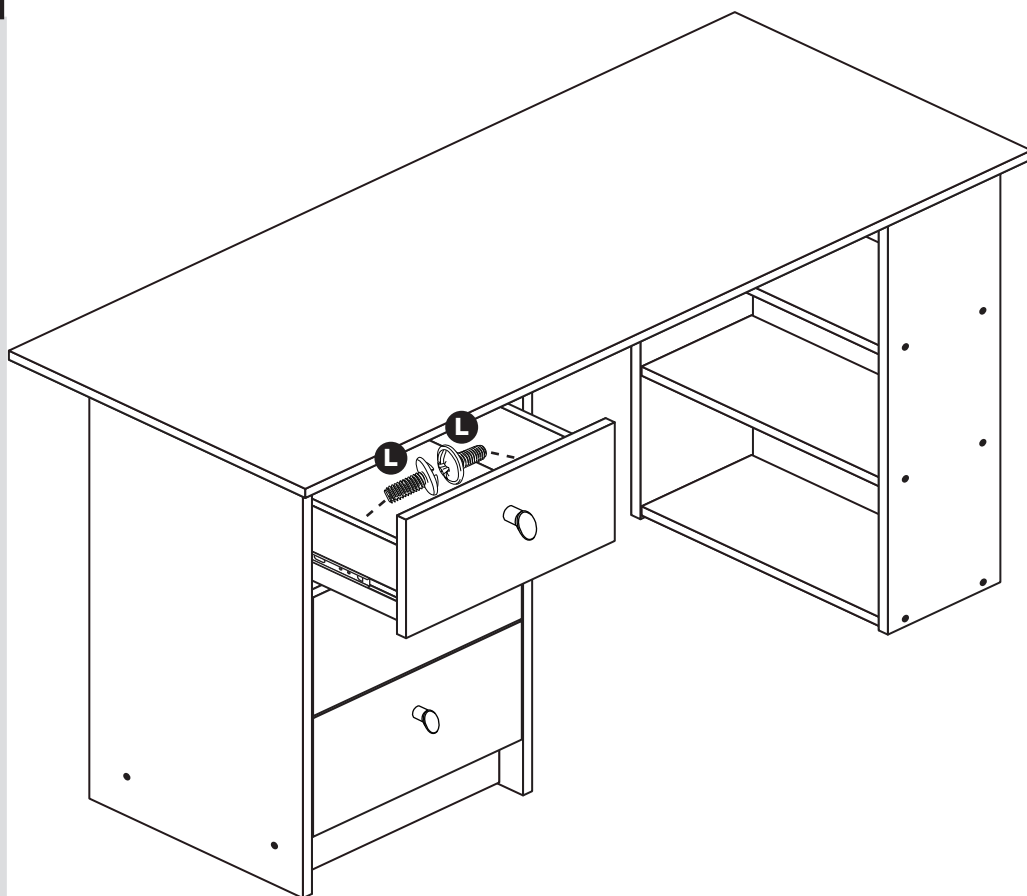

Note: Do not overtighten the screws. If they catch on the runner you may need to loosen them slightly.

If you need help or have damaged or missing parts, call the Customer Helpline: 08456 400800 and quote the reference numbers on the component pages.

Argos Ltd, 489-499 Avebury Boulevard, Central Milton Keynes, MK9 2NW

Malibu

Assembly Instructions - Please keep for future reference

274/6616

247/3848

278/5220

268/6965

238/3615

275/3922

275/6297

278/6009

280/0332

247/7167

246/4950

246/5818

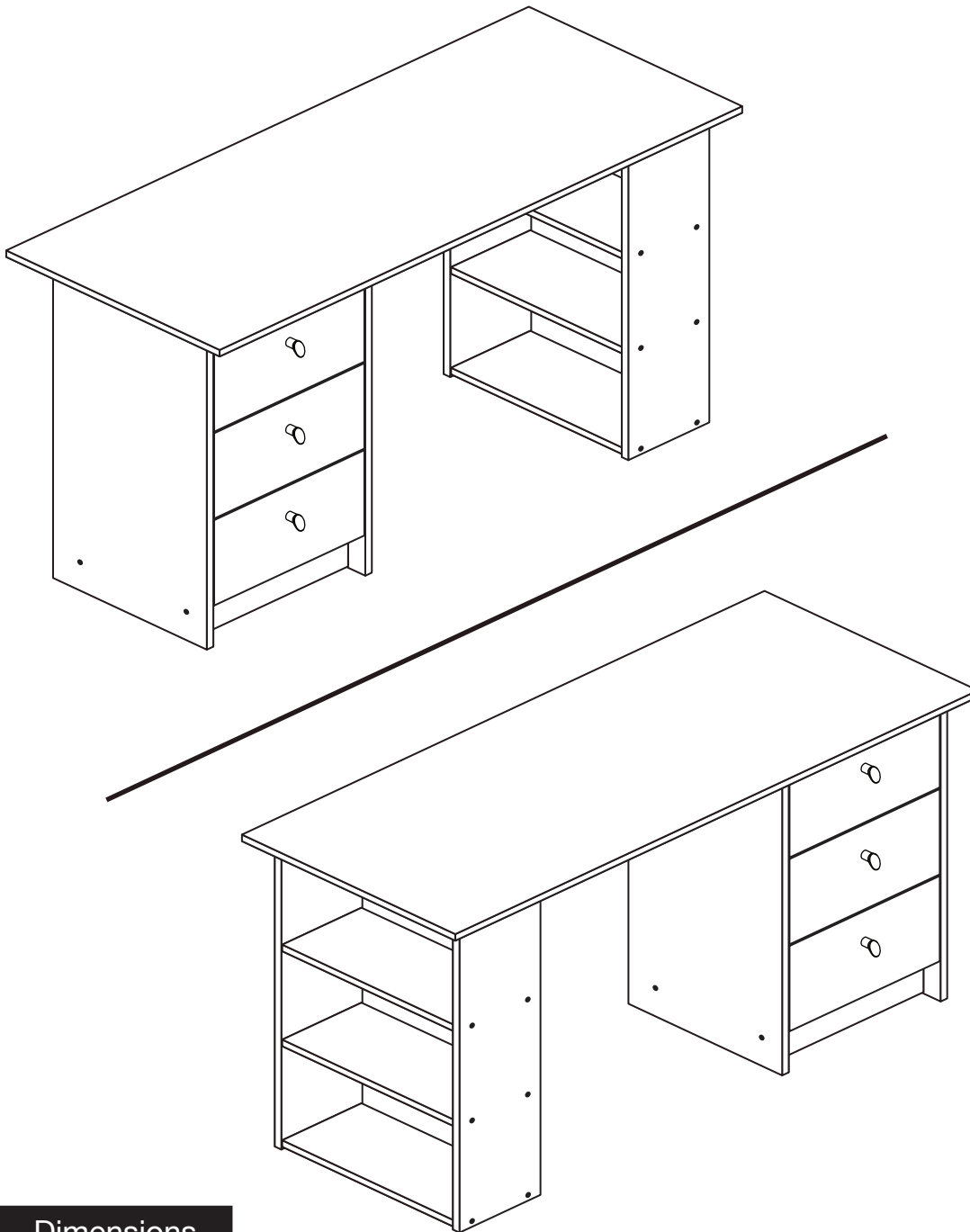

Dimensions

Width - 120cm

Depth - 49cm

Height - 72cm



**MADE IN
BRITAIN**

Important - Please read these instructions fully before starting assembly

If you need help or have damaged or missing parts, call the **Customer Helpline: 08456 400800**



Safety and Care Advice

Important - Please read these instructions fully before starting assembly

- **Warning:** This unit weighs approximately 24kgs. Please lift with care.

- Check you have all the components and tools listed on pages 2 and 3.

- Remove all fittings from the plastic bags and separate them into their groups.

- Keep children and animals away from the work area, small parts could choke if swallowed.

- Make sure you have enough space to layout the parts before starting.

- Do not stand or put weight on the product, this could cause damage.

- Assemble the item as close to its final position (in the same room) as possible.

- Assemble on a soft level surface to avoid damaging the unit or your floor (use opened out unit carton).



- We do not recommend the use of power drill/drivers **for inserting screws**, as this could damage the unit. Only use hand screwdrivers.

- **Safety note:** If there is any chance of this unit being pulled over by children etc. it is recommended that the unit is secured to a wall using suitable fixings (not supplied).

- Dispose of all packaging carefully and responsibly.

Care and maintenance

- Only clean using a damp cloth and mild detergent, do not use bleach or abrasive cleaners.

- From time to time check that there are no loose screws on this unit.

- This product should not be discarded with household waste. Take to your local authority waste disposal centre.

Note: If required the next page can be cut out and used as reference throughout the assembly. Keep this page with these instructions for future reference.

Components - Panels

If you have damaged or missing components, call the **Customer Helpline: 03456 400800** quoting the reference numbers below

Please check you have all the panels listed below

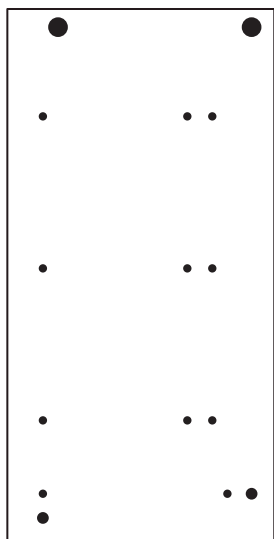

1 Left Side (D2785D)
(706 x 353mm)

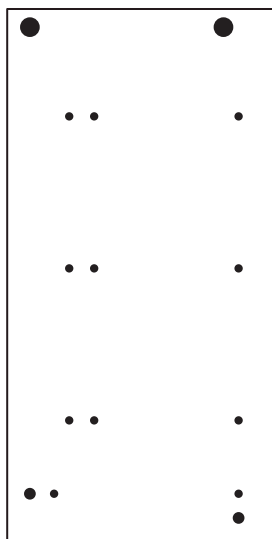

2 Right Side (D2786D)
(706 x 353mm)



3 Bookcase End (D2787D)
(706 x 186mm) x 2

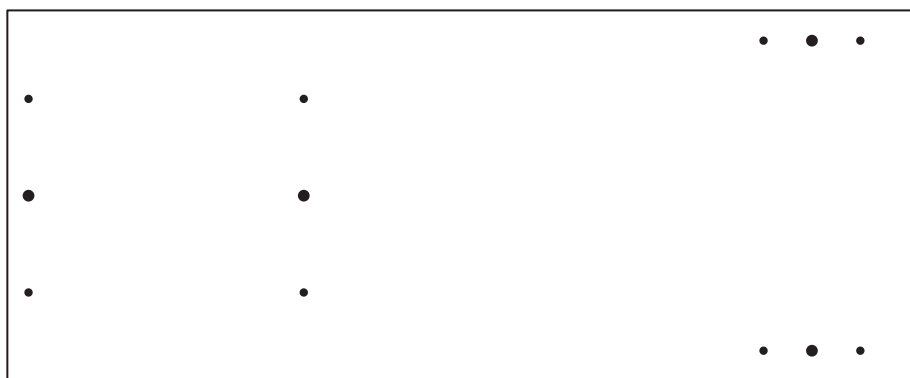

4 Top (D2784D)
(1200 x 490mm)



5 Shelf (D2788D)
(394 x 182mm) x 3



6 Plinth (D2789D)
(349 x 92mm)

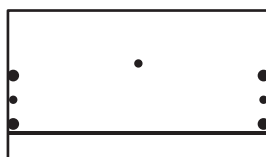

8 Drawer Front (D2791D)
(345 x 196mm) x 3

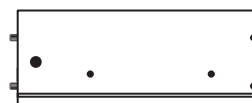

9 Left Drawer Side (W320-124LH)
(320 x 124mm) x 3



7 Rail (D2790D)
(349 x 80mm)

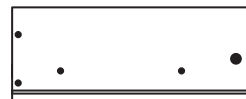

10 Right Drawer Side (W320-124RH)
(320 x 124mm) x 3

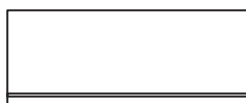

11 Drawer Back (W317-124)
(317 x 124mm) x 3

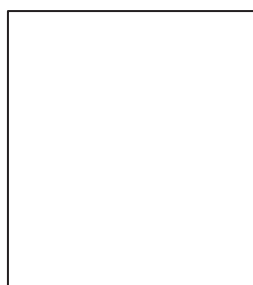

12 Drawer Base (T328-317)
(328 x 317mm) x 3

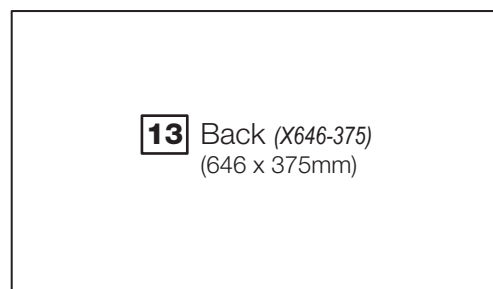

13 Back (X646-375)
(646 x 375mm)











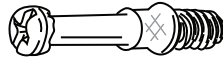
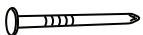



Components - Fittings

If you have damaged or missing components, call the **Customer Helpline: 03456 400800** quoting the reference numbers below

Please check you have all the fittings listed below

Note: The quantities below are the correct amount to complete the assembly. In some cases more fittings may be supplied than are required.

<p>A </p> <p>Wooden dowel (F22) x 8</p>	<p>B </p> <p>Metal dowel (F901) x 14</p>	<p>C </p> <p>Nail (F51) x 11</p>
<p>D </p> <p>Handle (F631) x 3</p>	<p>E </p> <p>Large locking nut (F900) x 8</p>	<p>F </p> <p>Small locking nut (F3) x 6</p>
<p>G </p> <p>40mm Screw (F910) x 16</p>	<p>H </p> <p>25mm Screw (F50) x 3</p>	<p>I </p> <p>Plastic Nail (F91) x 8</p>
<p>J </p> <p>Drawer runner (F1004) x 6</p>		<p>K </p> <p>9mm Screw (F73) x 12</p>
<p>L </p> <p>9mm Screw (F74) x 6</p>	<p>M </p> <p>Wedgefix (F639) x 6</p>	<p>N </p> <p>Knock-in Peg (F171GY) x 12</p>

Tools required

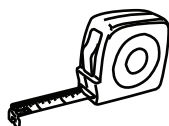

Rule



Cross-head screwdriver



Scissors



Hammer



Eye protection
(when using a hammer or drill)

Ruler - Use this ruler to help correctly identify the screws

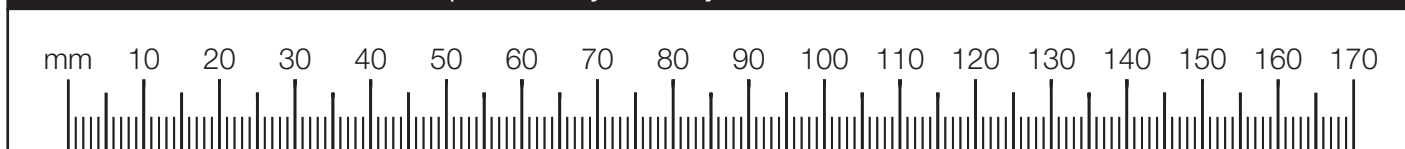

Assembly Instructions

If you have damaged or missing components, call the
Customer Helpline: 03456 400800 quoting the reference
numbers below

Step 1

Prepare the 3 drawer fronts

Screw 2 metal dowels **B** into each of the drawer fronts **8**.

Note: Tighten the metal dowels up fully against the panels.

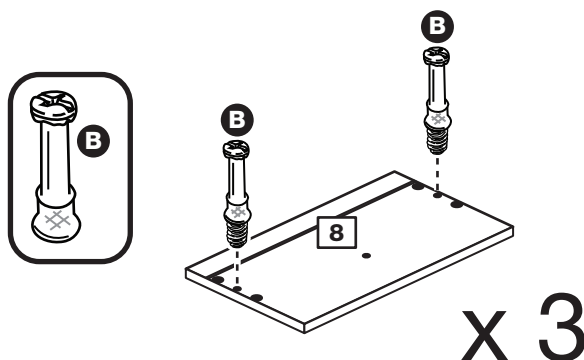

Step 2

Prepare the drawer sides

Insert a small locking nut **F** into the hole shown on the left drawer side **9** and the right drawer side **10**.

Note: The arrow on the locking nut **must** point towards the hole in the edge of the panel.

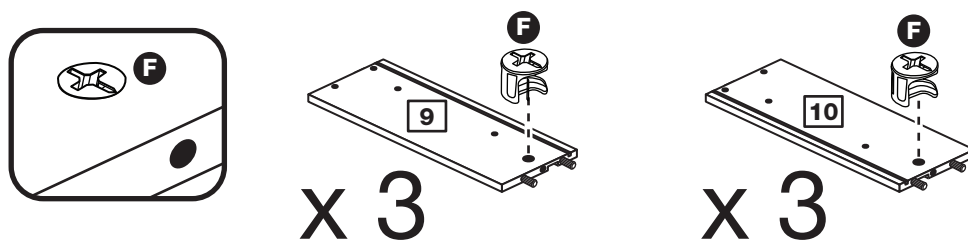

Step 3

Attach the drawer sides to the drawer fronts

Push the left drawer sides **9** and right drawer sides **10** onto the back of the drawer fronts **8**.

Turn the small locking nuts **F** on the left drawer side **9** and right drawer side **10**.

Note: Turn the locking nuts **F** clockwise to secure panels - more than 1/2 a turn.

Note: The locking nuts can be on either surface of the drawer sides. Make sure that the small groove is on the inside, as shown.

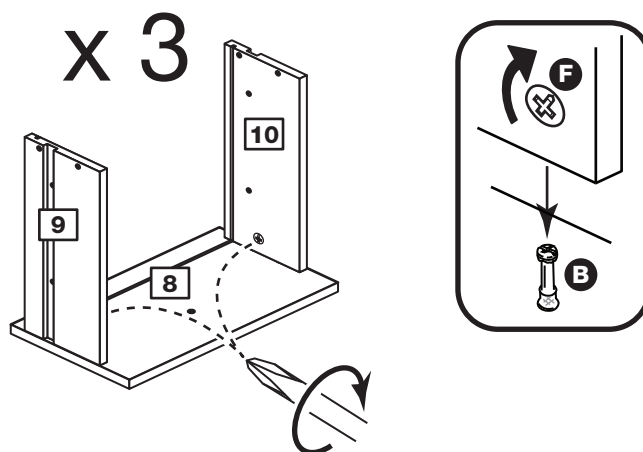

Assembly Instructions

Step 4

Fit the drawer base

Slide the drawer base **12** down the grooves in the drawer sides **9** and **10** and down into the groove in the drawer front **8**.

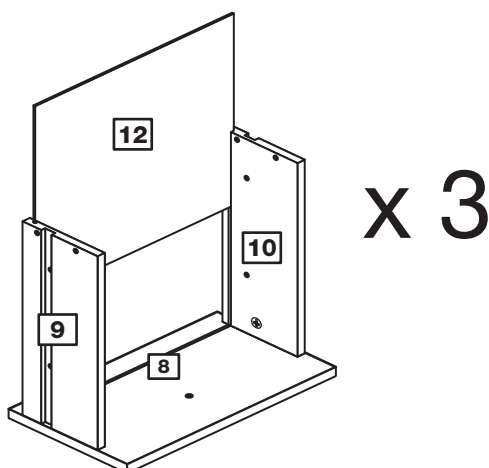

Step 5

Fit the drawer back

Fit the drawer back **11** between the drawer sides **9** and **10**. Make sure that the drawer base **12** fits into the groove in the drawer back **11**.

Hold the drawer back **11** in position and tap the knock-in pegs **N** through the holes in the drawer sides **9** and **10**.

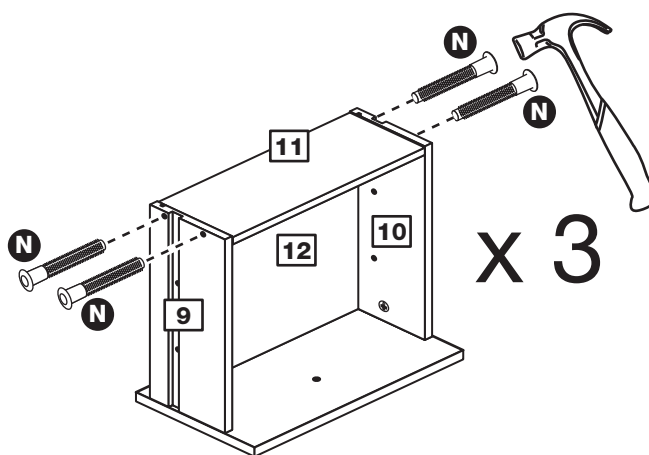

Step 6

Attach the handles

Attach a handle **D** to each of the drawer fronts **8** using screw **H**.

Note: Do not overtighten the screw.

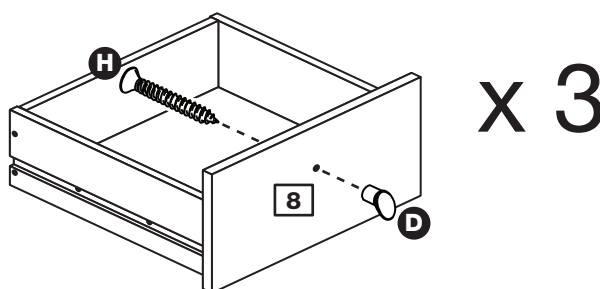

Step 7

Fit the wedgifixes

Turn the drawer assemblies over and slide 2 wedgifixes **M** into the front and back grooves, as shown, and tighten up the screws.

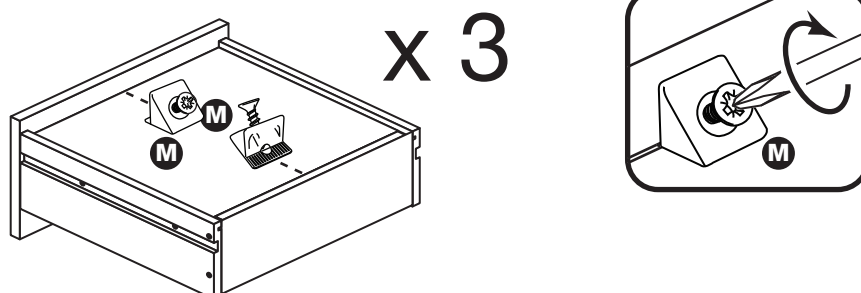

Assembly Instructions

Step 8

Prepare the left side

a: Place 3 runners **J** on the left side **1** as shown. Slide back the top of runner and use the 2nd hole from the front to fit the 1st screw **K**.

b: Slide the runner **J** back the other way and fit the 2nd screw **K** into the corresponding hole in the left side **1**.

Insert 2 large locking nuts **E** into the left side **1**.

Note: The arrow on the locking nuts **must** point towards the hole in the edge of the panel.

Tap a wooden dowel **A** into the left side **1**.

Note: Wooden dowels **must not** stick out from the edge by more than 10mm or they may damage other panels.

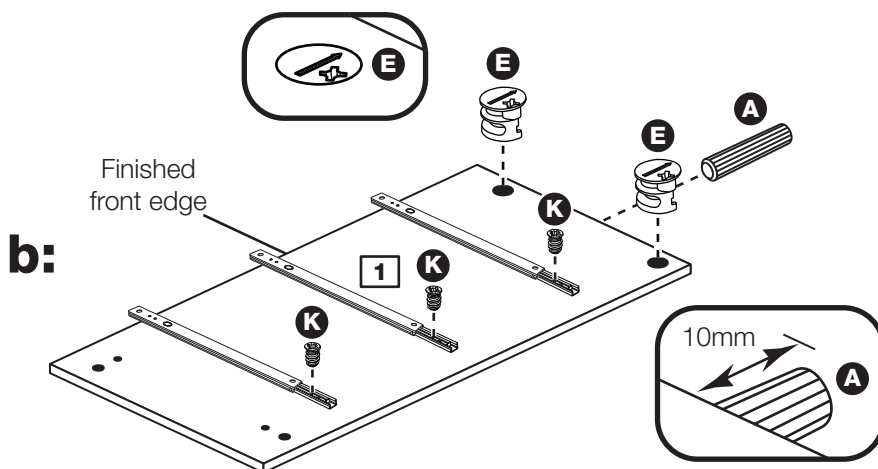
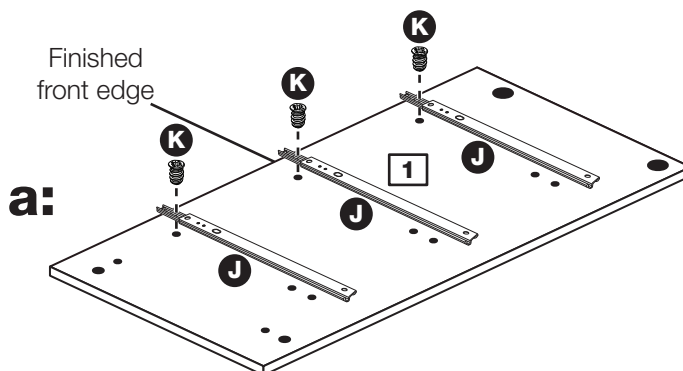
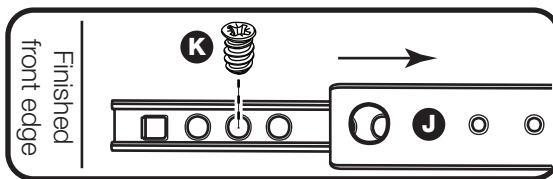

Assembly Instructions

Step 9

Prepare the right side

a: Place 3 runners **J** on the right side **2** as shown. Slide back the top of runner and use the 2nd hole from the front to fit the 1st screw **K**.

b: Slide the runner **J** back the other way and fit the 2nd screw **K** into the corresponding hole in the right side **2**.

Insert 2 large locking nuts **E** into the right side **2**.

Note: The arrow on the locking nuts **must** point towards the hole in the edge of the panel.

Tap a wooden dowel **A** into the right side **2**.

Note: Wooden dowels **must not** stick out from the edge by more than 10mm or they may damage other panels.

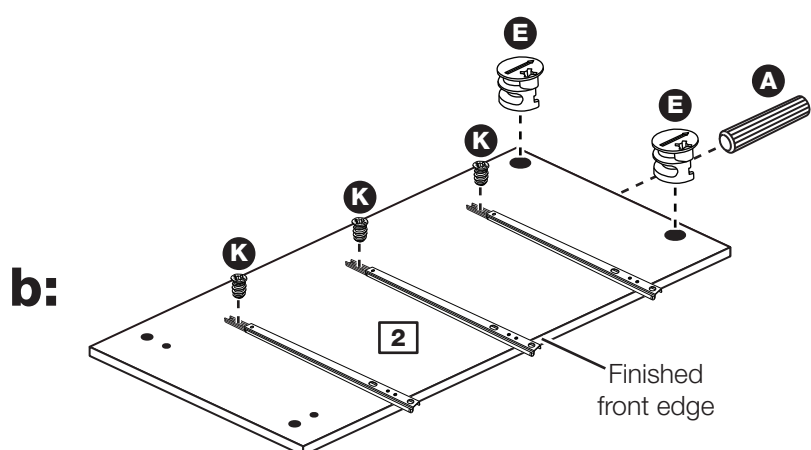
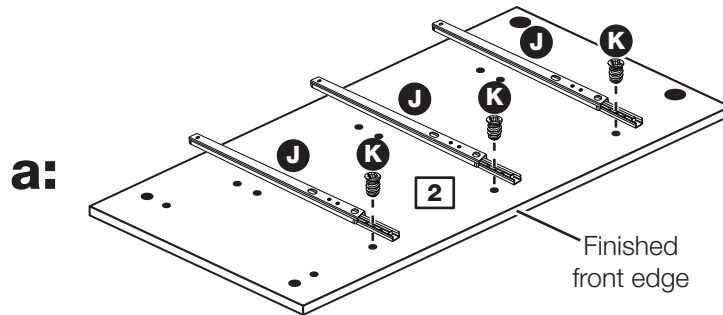
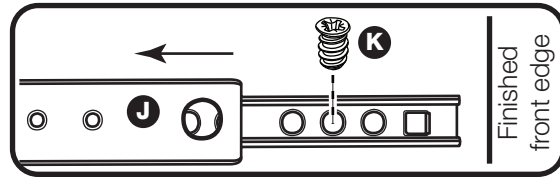

Step 10

Prepare the plinth and the rail

Tap 2 wooden dowels **A** into the plinth **6**.

Tap 2 wooden dowels **A** into the rail **7**.

Note: The plinth will be finished with the main unit colour on one surface.

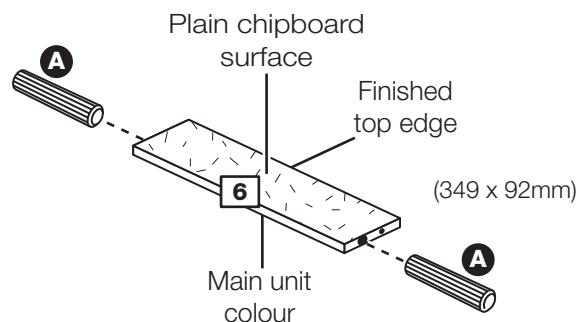

Note: The rail may be plain chipboard or its colour may differ from the main unit colour.

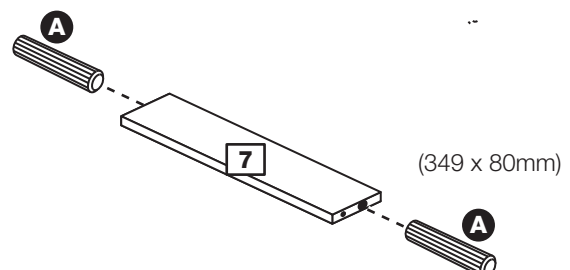

Assembly Instructions

Step 11

Fit the plinth and the rail to the right side

Push the plinth **6** onto the right side **2** and secure it with screw **G**.

Push the rail **7** onto the right side **2** and secure it with screw **G**.

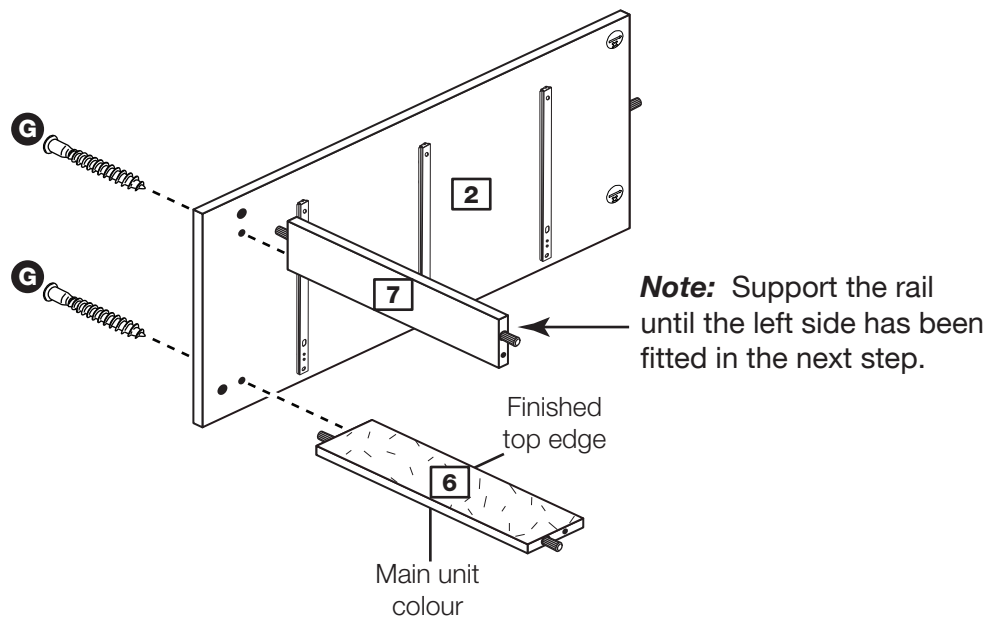

Step 12

Fit the left side

Push the left side **1** onto the unit and secure it with 2 screws **G**.

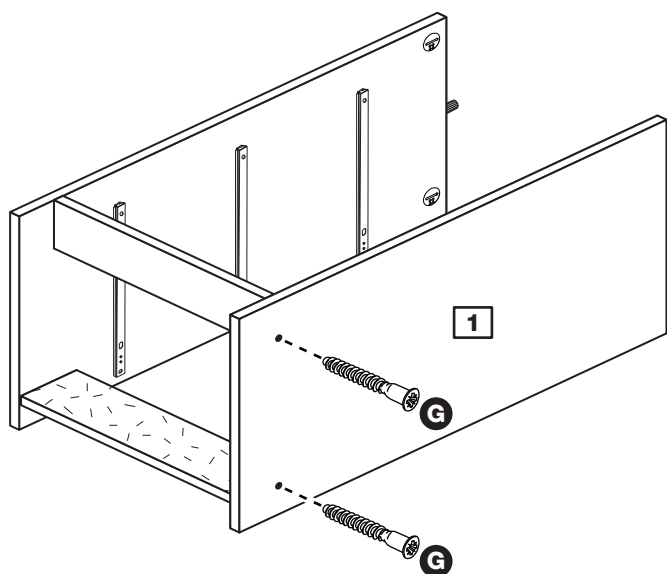

Step 13

Fit 4 plastic nails

Tap 2 plastic nails **I** into the bottom edge of each side **1** and **2** as shown.

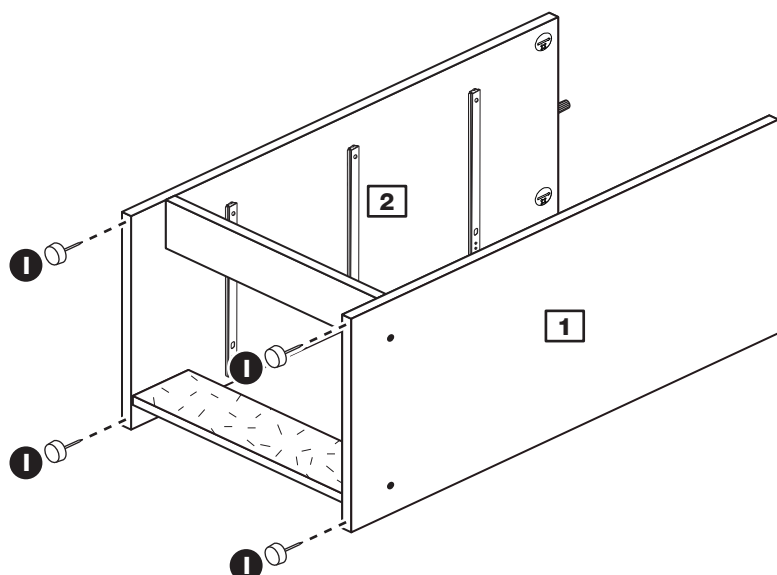

Assembly Instructions

Step 14

Fit the back

a: Square up the unit by making sure that measurement **x to x** equals **y to y**.

b: Place the back **13** down onto the unit, making sure that it is flush with the bottom of the rail **7**.

Nail **C** down the sides and along the bottom edge of the back **13**.

Note: Nails should be spaced about 150mm apart.

a: The measurement from top corner X to bottom corner X must be equal to the measurement from top corner Y to bottom corner Y

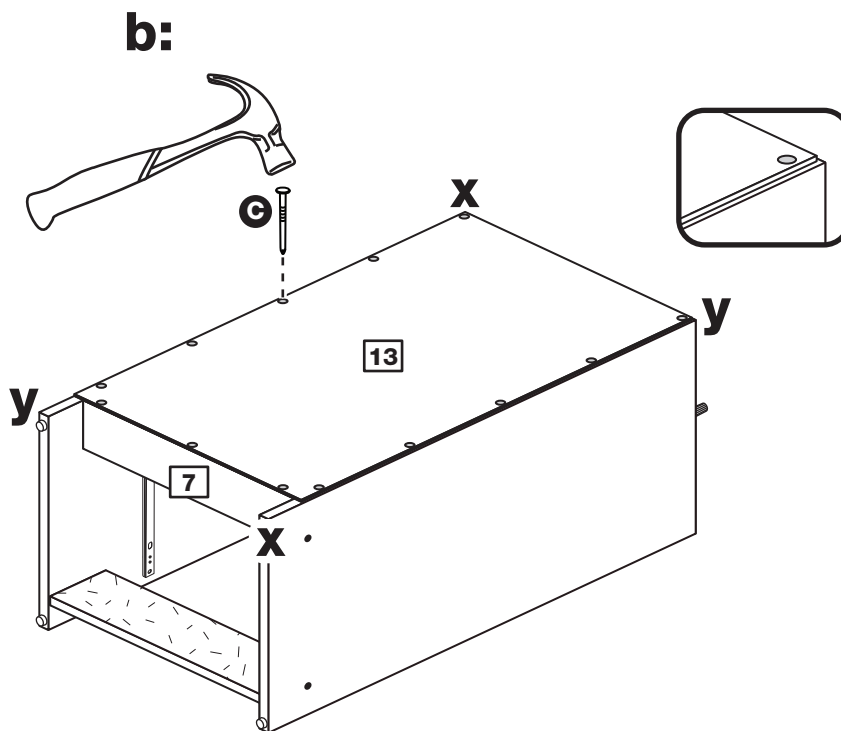

Step 15

Prepare the 2 bookcase ends

Insert 2 large locking nuts **E** into each bookcase end **3**.

Tap a wooden dowel **A** into each bookcase end **3**.

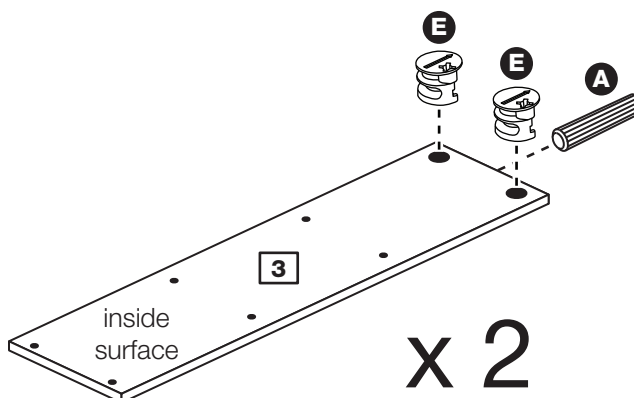

Assembly Instructions

Step 16

Fit the shelves to the bookcase ends

Attach the 3 shelves **5** to the bookcase ends **3** using 12 screws **G**.

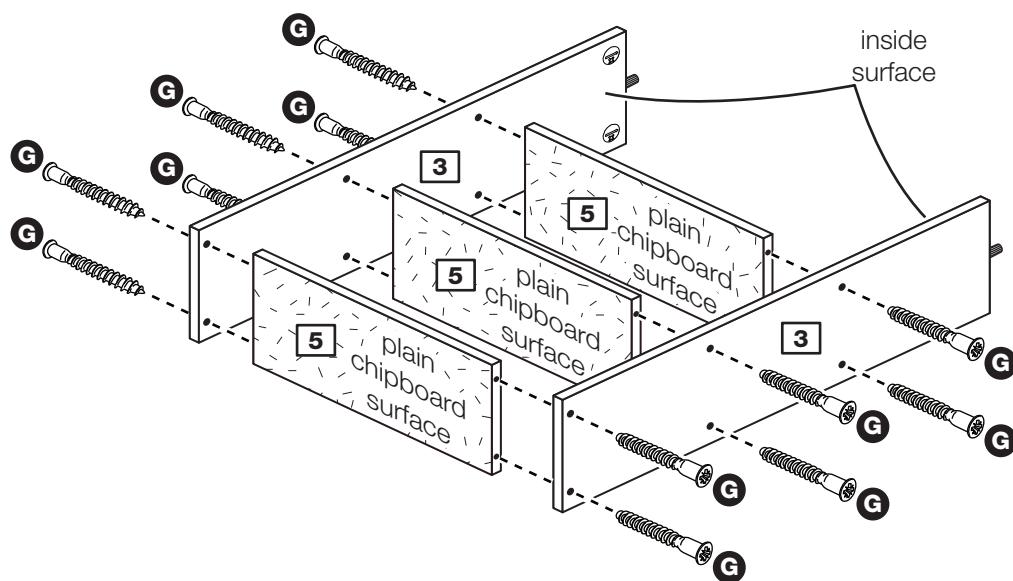

Step 17

Fit 4 plastic nails

Tap 2 plastic nails **I** into the bottom edge of each bookcase end **3** as shown.

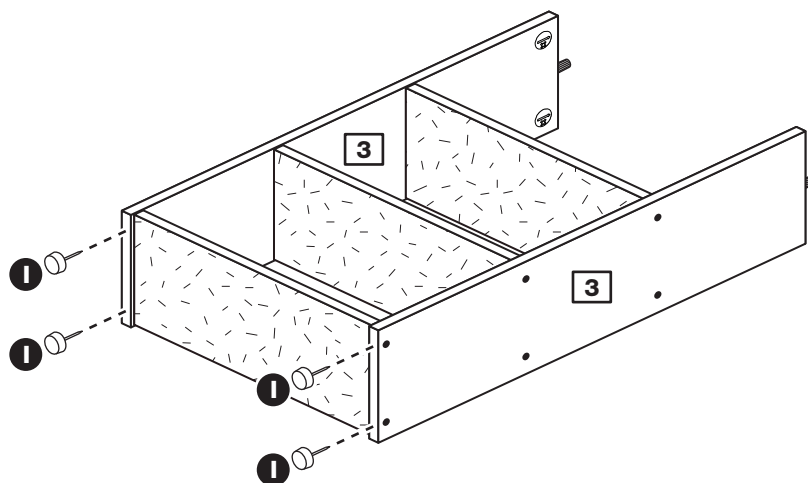

Assembly Instructions

Step 18

Choose desk layout

Before going onto the next step, decide which way around you would like your desk to be.

Place the 2 assemblies where the desk will be used, so that the unit does not have to be moved once the top panel has been secured into place.

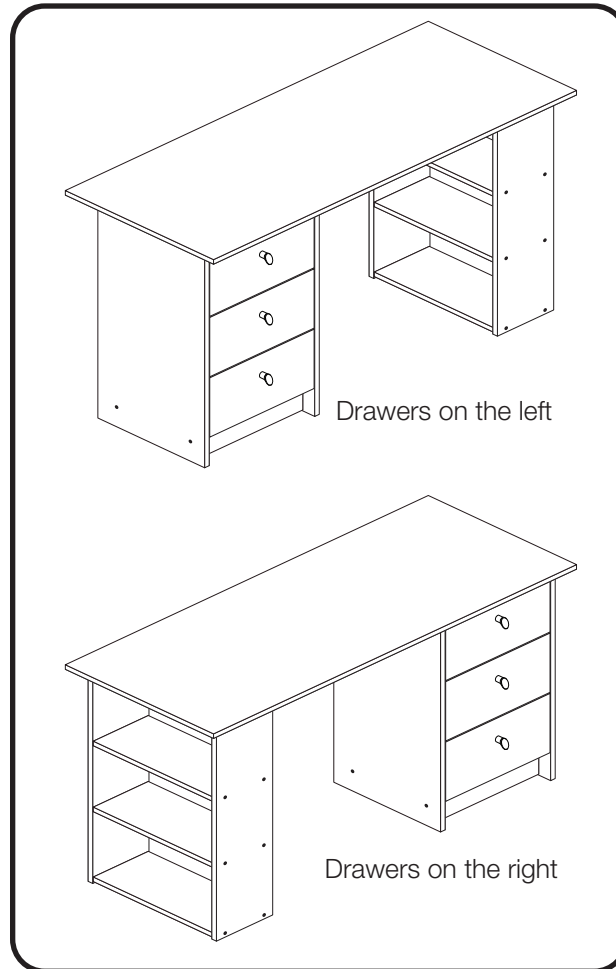

Step 19

Prepare the top

Screw 8 metal dowels **B** into the top **4**.

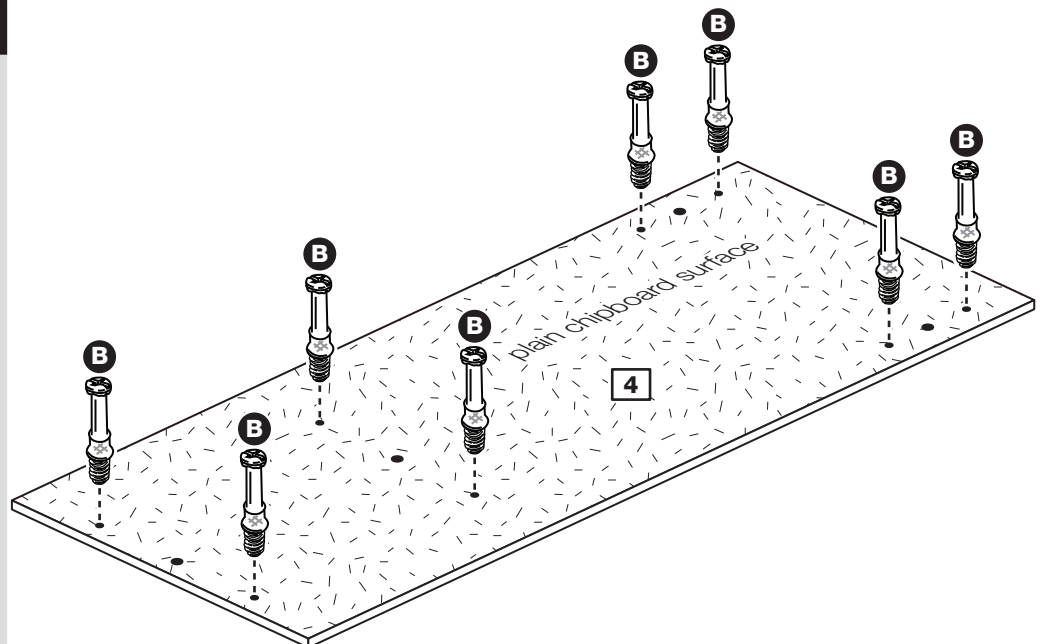

Assembly Instructions

Step 20

Fit the top

Lift the top **4** and push the 8 metal dowels **B** fitted to the top **4** down into the holes in the top edge of the sides and bookcase ends **1**, **2** and **3**.

Use a screwdriver to tighten the 8 large locking nuts **E** fitted to the sides and bookcase end panels **1**, **2** and **3**.

Note: Turn the large locking nuts **E** as far as they will go - more than 1/2 a turn.

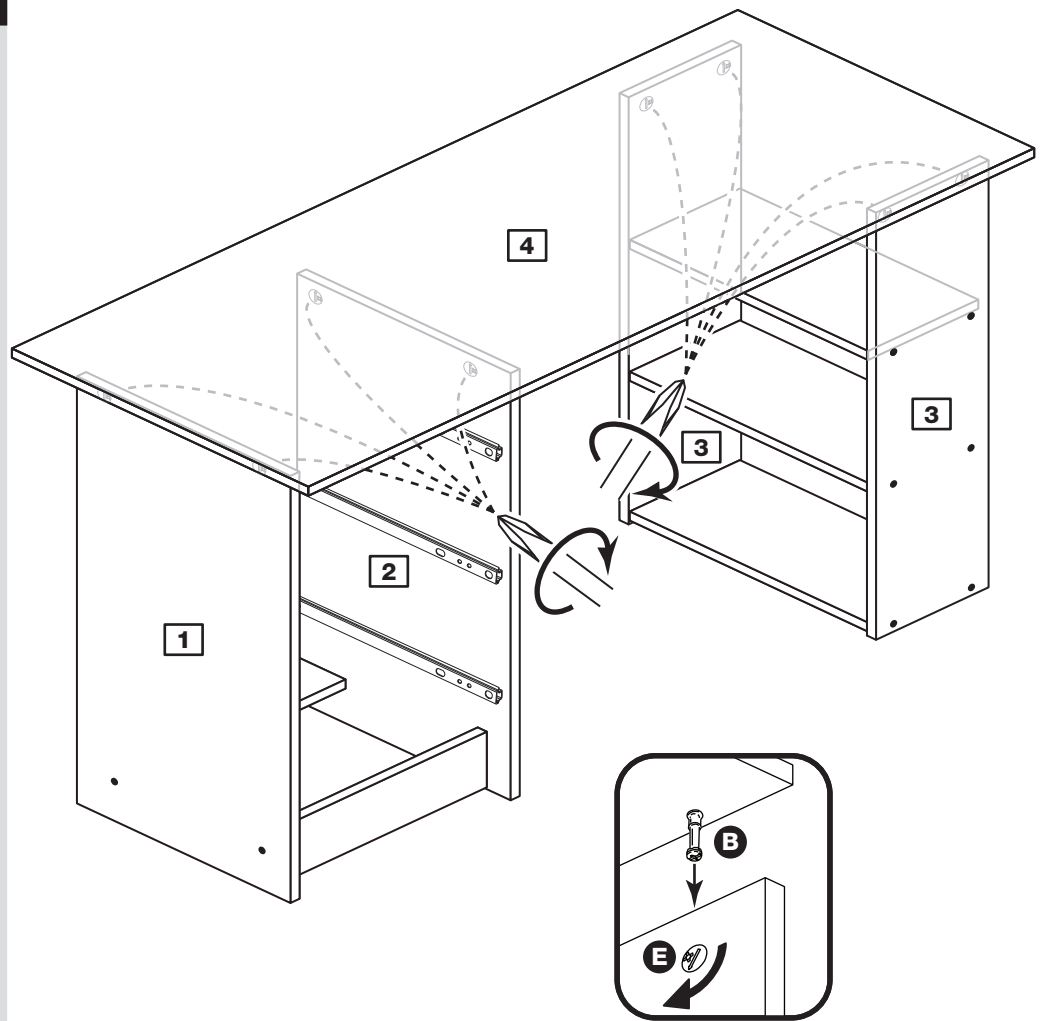

Assembly Instructions

Step 21

Fit the drawers

Starting with the bottom drawer, slide both the runners **J** forward and locate the drawer sides **9** and **10** between them, lining up the holes in the drawer wrap with the 2nd 'threaded' holes in the runners **J**.

Working from the inside of the drawer, insert 2 screws **L** through the drawer sides and out into the 2nd threaded hole in the runner.

Assembly is complete



Warning: The unit is heavy. Lift with care.

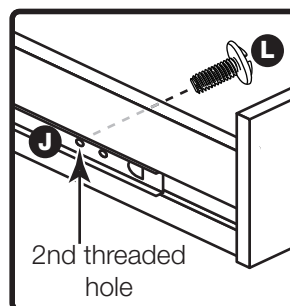
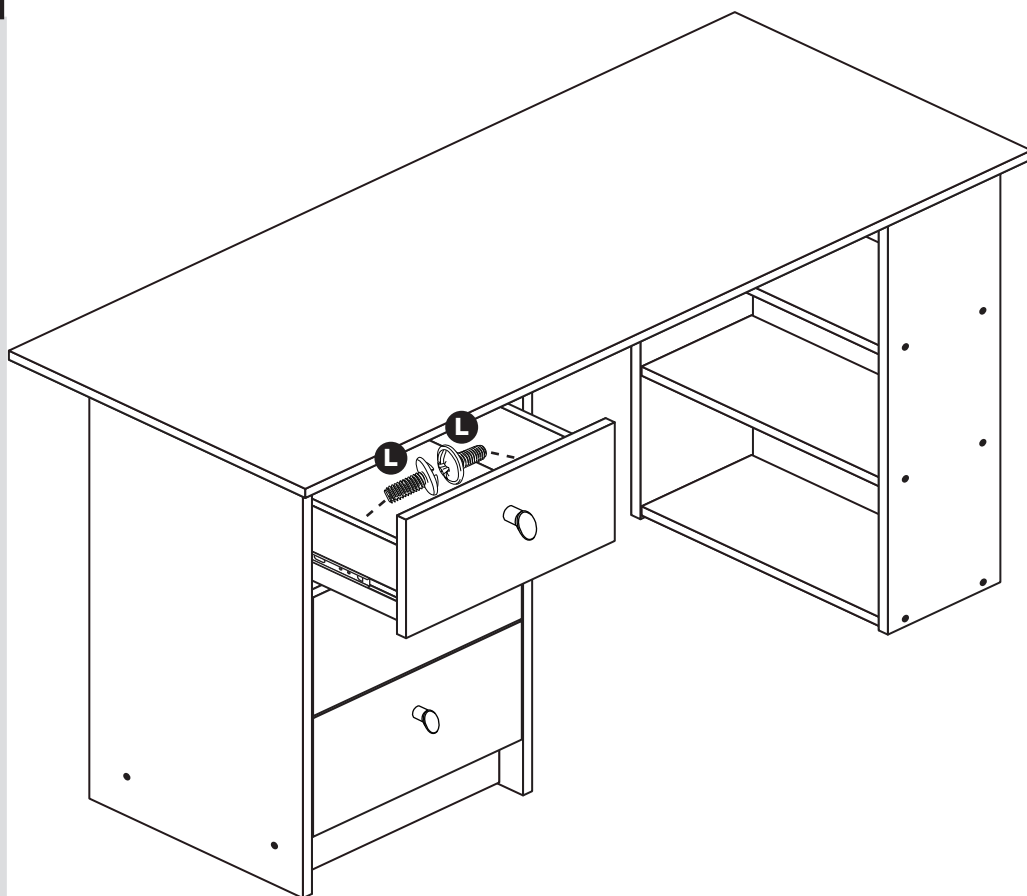

Note: Do not overtighten the screws. If they catch on the runner you may need to loosen them slightly.

If you need help or have damaged or missing parts, call the Customer Helpline: 03456 400800 and quote the reference numbers on the component pages.

Argos Ltd, 489-499 Avebury Boulevard, Central Milton Keynes, MK9 2NW

