

BDWF60W
60 cm full height
freestanding
dishwasher

INSTRUCTION MANUAL

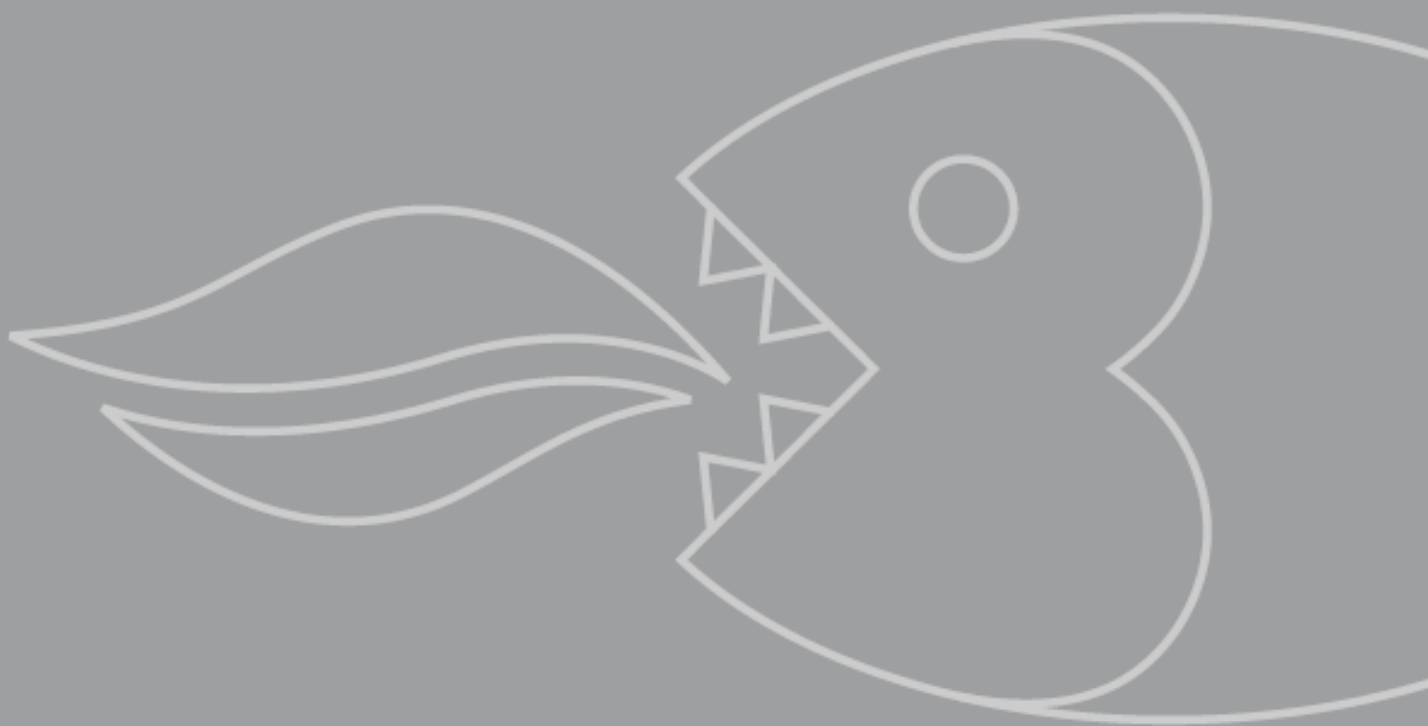

USER MANUAL FOR YOUR BAUMATIC

BDWF60W 60 cm full height freestanding dishwasher

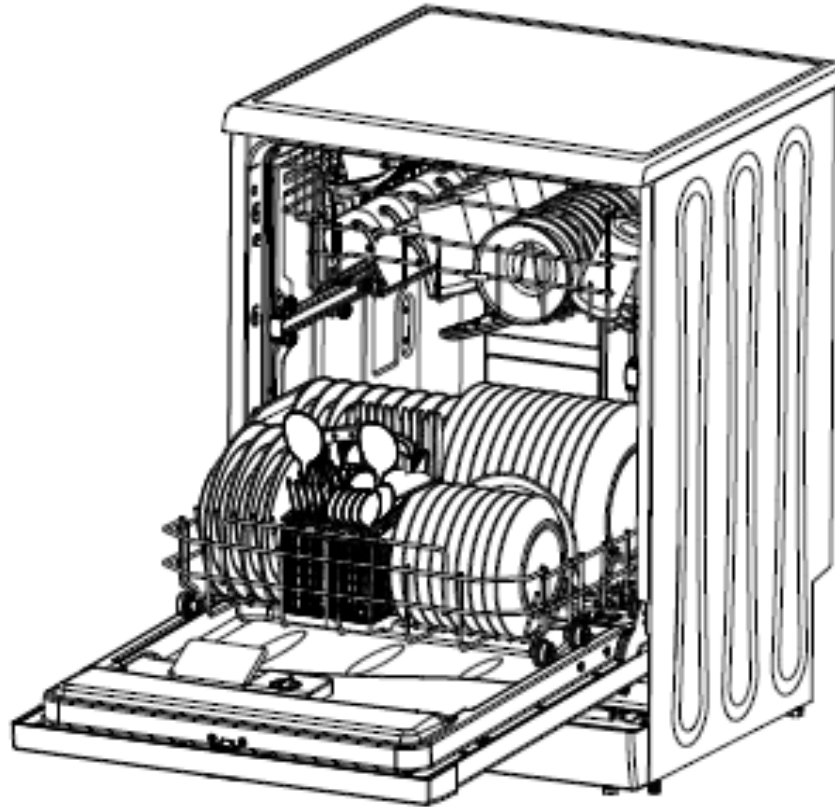

NOTE: This User Instruction Manual contains important information, including safety & installation points, which will enable you to get the most out of your appliance. Please keep it in a safe place so that it is easily available for future reference; for you or any person not familiar with the operation of the appliance.

Contents

Environmental note	3
Important safety information	4 – 6
Specifications	7 – 10
Product and aperture dimensions	7
Product specifications	7 - 8
Electrical details	8
Description of the appliance	9
Control panel	10
Using your dishwasher	10 - 21
Before first use	10
Filling with dishwasher salt	11
Setting the water softener level	12
Filling with rinse aid	13
Setting the rinse aid level	14
Filling with dishwasher detergent	14 - 15
Loading the upper basket	16
Adjusting the upper basket	16
Loading the lower basket	17
The cutlery basket	18
Loading dishes and cutlery	18 - 19
Program table	20
Setting a wash program	21
Changing a wash program	21
At the end of a wash program	22
Adding an item to the wash cycle	22
Delay start	22
Rinse aid and salt indicator neons	22
Saving energy using your dishwasher	23 - 24
Cleaning and maintenance	24 - 26
The filter system	24
Cleaning the filters	24 - 25
Cleaning the spray arms	25
Cleaning the control panel	25
Cleaning the door	26
Error code failure system	26 - 29
General troubleshooting	28 – 29
Installation	30 - 34
Connecting to the mains water supply	30
Connecting to the water outlet	31
Connecting to the power supply	32
Levelling the appliance	33
Before first use	34
Technical data	34
Contact details	38

ENVIRONMENTAL NOTE

Note: Before discarding an old appliance, switch off and disconnect it from the power supply. Cut off and render any plug useless. Cut the cable off directly behind the appliance to prevent misuse. This should be undertaken by a competent person. Disable the door lock to make sure that children cannot get stuck inside the appliance.

This appliance is marked according to the European directive 2002/96/EC on Waste electrical and Electronic Equipment (WEEE). By ensuring this product is disposed of correctly, you will help prevent potential negative consequences for the environment and human health, which could otherwise be caused by inappropriate waste handling of this product.

The symbol  on the product, or on the documents accompanying the product, indicates that this appliance may not be treated as household waste. Instead it shall be handed over to the applicable collection point for the recycling of electrical and electronic equipment.

Disposal must be carried out in accordance with local environmental regulations for waste disposal.

For more detailed information about treatment, recovery and recycling of this product, please contact your local city office, your household waste disposal service or the shop where you purchased the product.



- The packaging materials that Baumatic uses are environmentally friendly and can be recycled.
- Please discard all packaging material with due regard for the environment.

IMPORTANT SAFETY INFORMATION



Your safety is of the utmost importance to Baumatic. Please make sure that you read this instruction booklet **before** attempting to install or use the appliance. If you are unsure of any of the information contained in this booklet, please contact the Customer Care department.

General Safety

- Repairs to your appliance must only be carried out by authorised service agents. Any attempt by an inexperienced person to repair the appliance, could result in injury or damage to your dishwasher.
- If you notice that the mains cable is damaged. **The appliance must not be used.** The same applies if you notice that the worktop, control panel or base area is damaged. As this could allow access to the internal components of the machine.
- The appliance should be turned off and isolated from the mains supply, before either cleaning or maintenance work is attempted.
- The mains cable must not be used to pull the plug out of the electrical socket.
- The machine should not be sprayed with water.
- The external surface of the appliance may become hot whilst your dishwasher is in use.
- It is possible for small animals to chew either mains cables or water hoses, which could cause an electric shock hazard.

Installation

- The installation instructions contained within this user manual should be followed.
- It is obligatory for the completed installation to comply with all relevant building regulations and local water authority requirements.
- **Before the first use of the appliance, you should follow the steps listed in the "Before first use" section on page 10 and page 33 of this manual.**

- Care should be taken not to trap the power supply cable underneath the appliance whilst installing it.
- No attempt should be made to alter or modify the specifications of this appliance.

In daily use

- This appliance is only designed to wash normal domestic washloads. If you use your dishwasher in any other way or it is incorrectly used, then the manufacturer accepts no liability for any damage that might be caused and any guarantee will be void.
- It is recommended that the appliance is unplugged and the water supply is turned off after the machine is used.
- The detergents, rinse aid and salt that you place in this appliance should be suitable for automatic dishwashers. With regards to dosage levels, the detergent manufacturer's recommendations should be followed.
- Sharp knives or ones with long blades are a potential safety hazard when placed in an upright position in the cutlery basket. We would recommend that these items are placed horizontally in the upper basket.
- ***You should not*** wash any items that have come into contact with corrosive, acidic or alkaline chemicals, paint, petrol, iron or steel debris.
- ***You should not*** open the door whilst the appliance is set on a wash program. Depending on which stage that the wash program is at, hot water could escape the machine.
- ***You should not*** leave the door of the appliance open, unless you are loading or unloading the dishwasher.
- ***You should not*** stand or sit on the door when it is open.

Child Safety

- Your dishwasher should only be used by adults. You should not allow children in the area of the machine unsupervised. You should not let them touch the controls or play with the appliance.
- It could be possible for a child or pet to gain access to the dishwasher if the door is left open. Therefore please check the inside of the appliance before setting it on a wash cycle.
- Any packaging that is removed from the machine should be kept away from children.
- All detergents should be kept out of children's reach in a safe place.
- Some water will remain inside the dishwasher when it has completed a wash cycle. This water is not suitable for drinking and may contain residues from the detergents that are used in the appliance.

Declaration of conformity

This appliance complies with the following European Directives:

-73/23 dated 19/02/1973 Low Voltage Directive and subsequent modifications.

-89/336 dated 03/05/1989 Electromagnetic Compatibility Directive and subsequent modifications.

Specifications

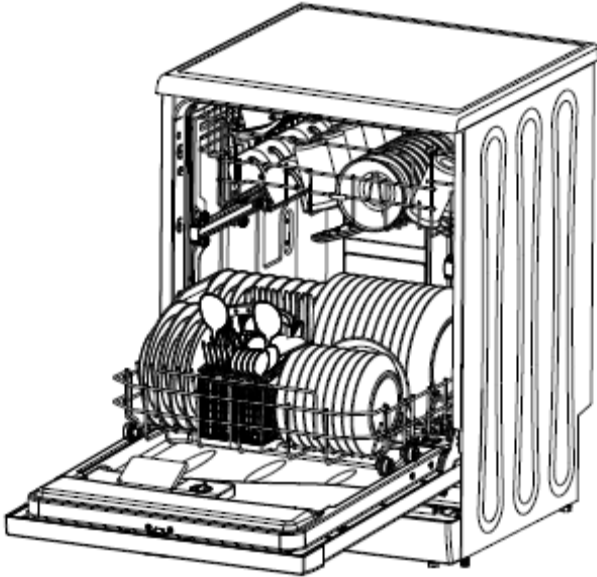

Product dimensions

Height: 850 - 870 mm
Width: 596 mm
Depth: 590 mm

Product specifications

- **12 Place settings**
- **6 functions:** Normal
Intensive
Economy
Crystal
Rapid
Rinse
- **4 temperatures:** 40°C, 45°C, 50°C, 60°C
- Noise level: 49 dB
- Self-cleaning stainless steel micro-filter
- Delay start
- Anti-leak device
- Anti-flood device
- Concealed heating element
- Collapsible plate racks
- Height adjustable upper basket
- Adjustable feet
- Residual drying

Energy efficiency details

Energy efficiency class: A+

Washing performance class: A

Drying performance class: A

Power consumption

Off mode: 0.10 W

Left on mode: 0.49 W

Electrical details

Rated voltage: 220-240 Vac 50 Hz

Supply connection: 13 A (double pole switched fused outlet with 3 mm contact gap)

For future reference please record the following information which can be found on the rating plate and the date of purchase which can be found on your sales invoice. The rating plate of your dishwasher is located on the right hand side of the drop down door.

Model Number

Serial Number

Date of Purchase

Description of the appliance

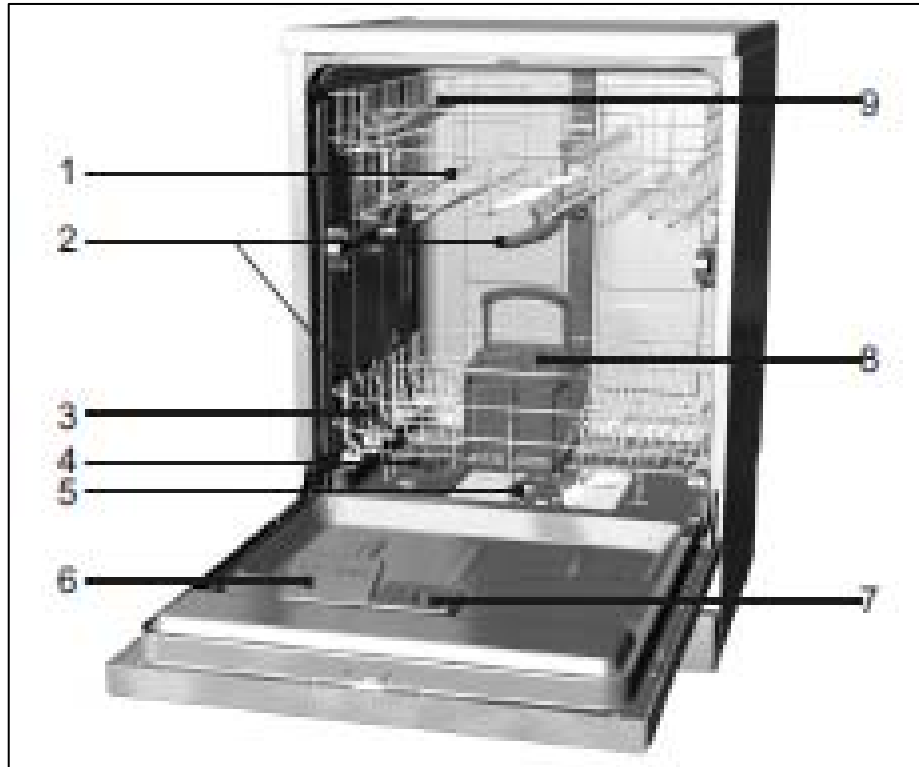

- 1) Upper basket
- 2) Spray arms
- 3) Lower basket
- 4) Water softener
- 5) Main filter
- 6) Detergent dispenser
- 7) Rinse Aid dispenser
- 8) Cutlery basket
- 9) Cup holder

Control panel

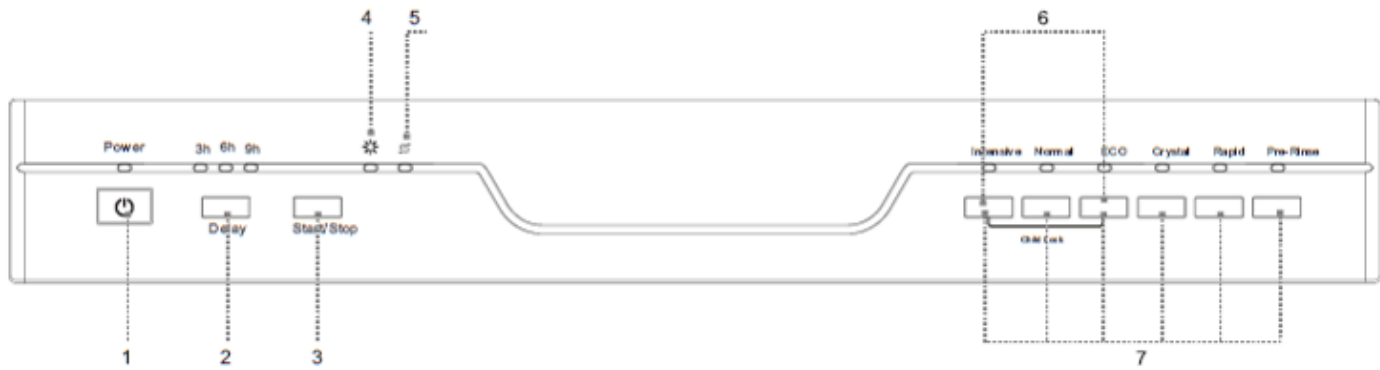

- 1) ON/OFF button
- 2) Delay start button.
- 3) Start/Stop button
- 4) Rinse aid indicator neon
- 5) Salt indicator neon
- 6) Child lock (Intensive + Eco buttons)
- 7) Program selection buttons

Using your dishwasher

Before first use

- Install the appliance as per the installation instructions contained within this booklet.
- Fill the water softener with 500ml of tap water and then fill with specialist dishwasher salt. After this you should set the water softener level.
- Fill the rinse aid dispenser and then set the rinse aid dosage.

Filling with dishwasher salt



IMPORTANT: You should only use salt that is specially designed for use in a dishwasher. If any other type of salt is used in the appliance (in particular table salt), it will damage the water softener.

- Ideally you should fill the water softener with salt, just before you are about to run a wash program. This will help to clear any salt that may have overflowed from the water softener during the salt filling process.
- Open the door of the dishwasher and then remove the lower basket. The basket should be empty when you remove it.



- Turn the water softener cap anticlockwise and remove it.
- Pour 500ml of water into the water softener.

IMPORTANT: It is only necessary to do this when you fill the container with salt for the first time.



- Pour salt into the water softener, using the funnel that is supplied with the appliance. You should add approximately 2 kg of salt into the water softener.
- It is perfectly normal for a small amount of water to come out of the water softener, whilst you are filling it with salt. This does not mean that the water softener is filled with the correct amount of salt.
- Refit and fully tighten the water softener cap.
- The salt required warning light will go out approximately 2-6 hours after you have filled the water softener with salt, however the light may not go out for a few days depending on how much it is used. When the salt indicator neon lights on the control panel, then you should follow the filling with dishwasher salt procedure again.
- **IMPORTANT:** You do not need to pour 500ml of water into the container when you subsequently fill the water softener with salt.

Setting the water softener level

It is possible to regulate the amount of salt that the water softener will release during a wash cycle. The water softener should be set to a level that is appropriate for the hardness of your water (please refer to the table below).

WATER HARDNESS				Selector	Salt consumption (gram/cycle)	Usage (cycles/1 kg)
° dH	° fH	° Clarke	Mmol/L			
0-10	0-17	0-12.5	0-1.7	/	0	/
10-25	17-44	12.5-31.3	1.7-4.4	-	20	60
25-50	44-89	31.3-62.5	4.4-8.9	Mid	40	40
>50	>89	>62.5	>8.9	+	60	25

To alter the amount of salt that is released by the water softener, you should: -

- Remove the lower basket and unscrew the cap from the water softener.

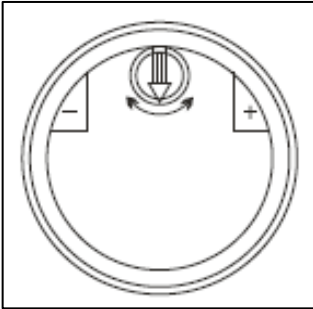

- Locate the ring with an arrow on it that is located on the water softener. (See figure opposite).
- Using the water hardness chart, you should turn the arrow to the setting that is appropriate for your water hardness.
- The "middle" selector position is halfway between the minus and plus symbols.
- **IMPORTANT:** If you are using 3 in 1 dishwasher tablets and live in a medium or hard water area, then you should still fill the water softener with salt. The water softener arrow should be turned to the minus setting.

Filling with rinse aid



The rinse aid is released during the final rinse and it helps to prevent water from forming droplets on your dishes. These droplets will lead to spots and streaks being left on items after the wash program has completed.

- Your dishwasher is designed to utilise liquid rinse aid.
- The rinse aid dispenser is located inside the drop down door, next to the detergent dispenser.

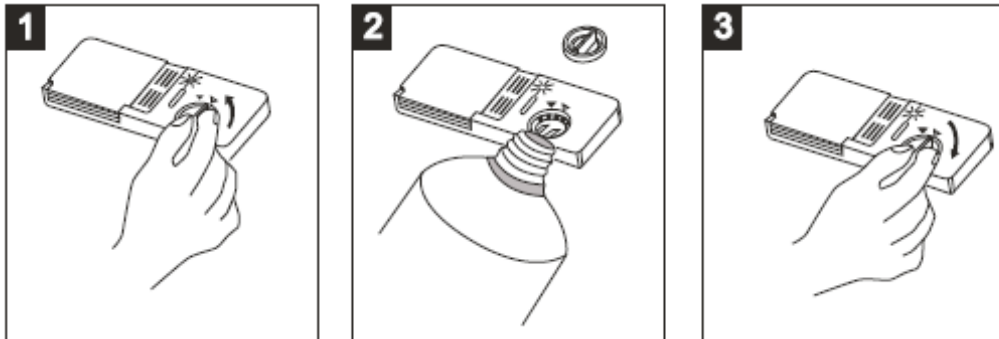

- To access the rinse aid dispenser, you should turn the cap anticlockwise and it will pop out of the hole. Then slowly pour in liquid rinse aid, the rinse aid dispenser will hold approximately 140 ml of rinse aid.
- You should continue to fill with rinse aid, until the level indicator turns completely black.
- Be careful not to overfill the dispenser, as this could cause oversudsing when a wash program is selected. Wipe away any rinse aid excess or spillages with a damp cloth.
- Replace the cap and turn it clockwise until it locks into position.
- You should refill the rinse aid dispenser when the rinse aid indicator neon lights on the control panel.
- **IMPORTANT:** *If you are using 3 in 1 dishwasher tablets then you should still fill the rinse aid dispenser.*

Setting the rinse aid level

The amount of rinse aid that the dishwasher requires also depends on the hardness of your water. You should experiment with the rinse aid setting, until you find a level that gives the best results.

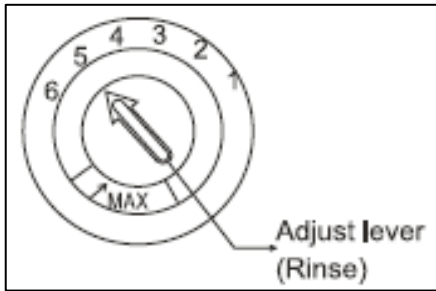

- On the first wash cycle, we would recommend that the rinse aid level is set to number 4.
- If you get water spots and poor drying performance, then you should turn the arrow anticlockwise and increase the setting to the next number.
- You should continue to adjust the rinse aid level upwards until you get no water spots.
- If you get cloudiness or streaking on your dishes, the rinse aid level is set too high and it is causing foaming during the wash cycle. Turn the arrow clockwise and lower the setting to the next number.

Filling with dishwasher detergent

The detergent dispenser must be refilled at the start of each wash cycle (apart from the Rinse wash program).

- Open the lid that closes over the detergent dispenser and place the detergent inside of the dispenser.

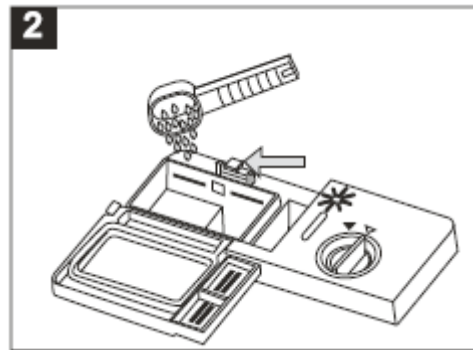
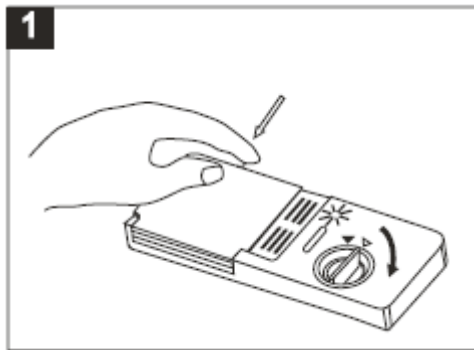

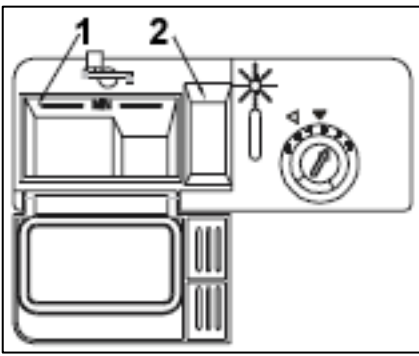

- The section marked 1 in the diagram is for the main wash cycle detergent. Only one detergent tablet should be placed in the dispenser at any one time. If you are using detergent powder or liquid, you should follow the detergent manufacturer's recommendations.
- The section marked 2 in the diagram can have separate detergent placed in it for any wash cycle that has a pre-wash element to it, however this is optional. This must be a liquid or powder detergent, not another detergent tablet.
- Shut the detergent dispenser lid and position the clip on the outer edge, so that it holds the lid shut.
- At the beginning of a wash cycle the clip will open and the tablet/powder/liquid will enter the dishwasher.

Concentrated detergent

- The use of the NORMAL program with concentrated detergents reduces pollution and is good for your dishes.
- This wash program is specifically suited to the dirt-dissolving properties of the enzymes of concentrated detergent. For this reason, the NORMAL program, in which concentrated detergent is used, can achieve the same results achieved in the INTENSIVE program.

Detergent tablets

- Different brands of detergent tablets dissolve at different speeds. For this reason, some detergent tablets cannot dissolve and develop their full cleaning power during short programs.
- It is recommended that you use longer programs when using detergent tablets to ensure the complete removal of detergent residues.

Loading the upper basket

The upper basket is most suited to washing delicate and light dishware, such as glasses, coffee & tea cups, saucers, plates, bowls and shallow pans (that are not heavily soiled).

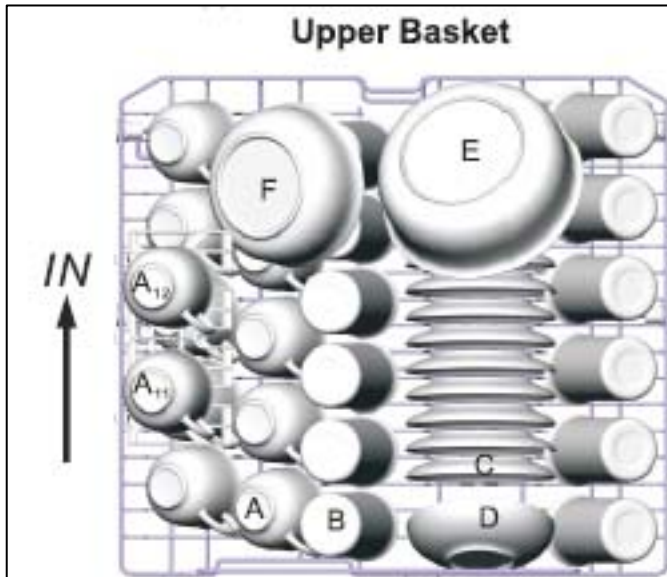

- A. Cups
- B. Glasses
- C. Saucers
- D. Small serving bowl
- E. Large serving bowl
- F. Dessert dish

- o You should position the dishes and cookware in such a way that they are not moved by the spray of water during the wash cycle.

- o Use the diagram above as a guide to the most appropriate way to load the upper basket.

Adjusting the upper basket

Your dishwasher has an adjustable upper basket which you can alter to the most suitable position for the items you are going to wash in the upper and lower baskets.



- o The height of the upper basket can be adjusted by placing the wheels on a different height of the rails. Long items such as cutlery, salad servers and knives should be placed on the shelf so they do not obstruct the rotation of the spray arms.
- o **IMPORTANT:** *The upper basket must be empty when you are removing it from the guide supports.*
- o NOTE: For easier stacking of pots and pans the cup shelf spikes can be folded down.

Loading the lower basket

The lower basket is most suited to washing larger and more heavily soiled items, such as saucepans, saucepan lids and serving dishes. You can also load bowls and a variety of plates into the lower basket.

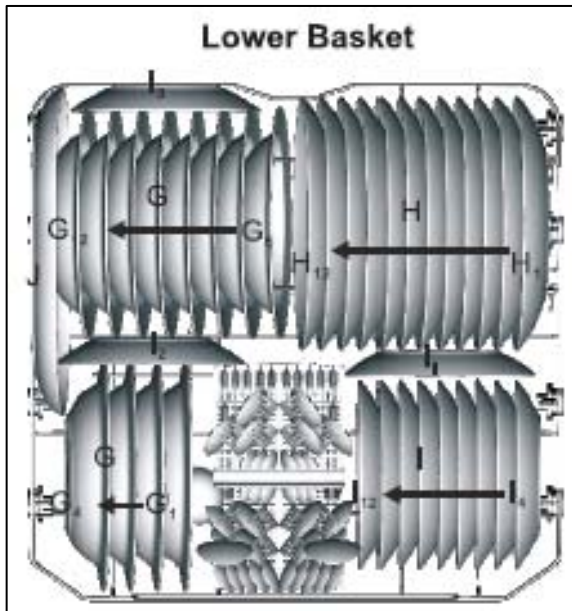

- G. Dessert dishes
- H. Dinner plates
- I. Side plates
- J. Serving plate

- o Saucepans and serving bowls must always be placed with their bases upwards.

- o Deep saucepans should be slanted, to allow water to run off.

Folding spikes of lower basket

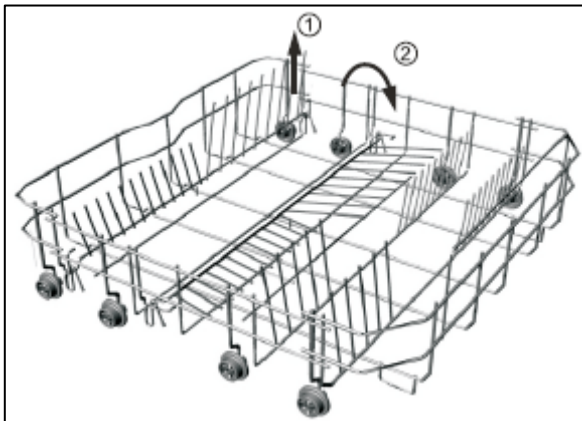

- o The bottom rack has prongs that can be folded downwards, to allow for easier loading of larger saucepans and serving bowls.

The cutlery basket

Cutlery should be placed inside of the cutlery basket. The cutlery basket should then be placed in the appropriate position in the lower basket.

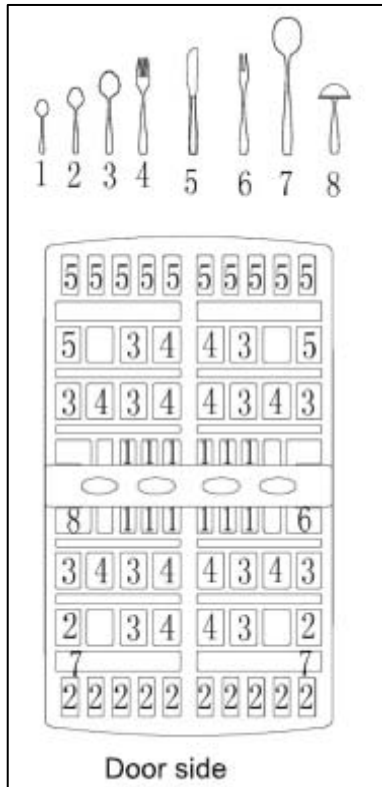

1. Teaspoons
2. Dessert spoons
3. Soup spoons
4. Forks
5. Knives
6. Serving fork
7. Serving spoon
8. Gravy ladle

- For the best washing performance, cutlery should be placed through the slots in the top of the cutlery basket.

IMPORTANT: Do not allow items of cutlery to fall through the bottom of the cutlery basket, as this may cause damage to the spray arm and/or the cutlery. If the bottom of the basket begins to deteriorate and allows items to fall through, you should replace the cutlery basket.

Loading dishes and cutlery



Household cloths, sponges or any other object that may absorb water SHOULD NOT be washed in a dishwasher.

- Remove leftovers and soften the remnants of burnt food in pans, prior to loading dishes in the appliance.
- Once the dishwasher has been loaded, check that the spray arms can move freely. If the spray arm comes into contact with any item, then you should rearrange the wash load.
- Cups, glasses, pans etc should all be loaded with their bases upwards, so that water does not collect inside of them.
- Cutlery and dishes should not cover each other; otherwise you may get poor wash results.
- Do not allow glasses to touch inside the dishwasher, otherwise damage may occur.
- Small objects can be placed inside of the cutlery basket.



The following items are NOT suitable for washing inside a dishwasher:-

- Cutlery with a handle of mother-of-pearl, wood, horn or china.
- Plastic items that are not resistant to heat.
- Cutlery that consists of glued parts that are not resistant to heat.
- Cutlery items or crockery that are bonded.
- Copper or pewter items.
- Lead crystal glass.
- Wooden platters.
- Synthetic fibre items.



The following items are not always suitable for washing inside a dishwasher:-

- Stoneware should only be washed if the manufacturer of the item has marked it as dishwasher safe.
- Plastic items (such as lunchboxes) should only be washed if the manufacturer has marked it as dishwasher safe.
- Glazed crockery may fade with repeated washing inside of a dishwasher.
- Items made of silverware or aluminium can discolour when washed inside a dishwasher.
- Any food residue should be removed from silver items immediately, as this can also result in discolouration.
- Certain types of glass may become dull or cloudy after a large number of washes.

Program table

- The ECONOMY program is suitable for cleaning a typical load of dirty dishes and is the most efficient in terms of its combined energy and water consumption.

Program	Program information	Description of cycle	Detergent pre/main	Program times*	Energy (kWh)	Water (L)
Normal **	For normally soiled loads, such as pots, plates, glasses and lightly soiled pans.	Pre-wash Rinse Wash (50°C) Hot rinse Drying	5 grams (pre-rinse) 25 grams (main wash)	153 Minutes	1.05	14
Intensive	For the heaviest soiled loads, such as pots, pans, casserole dishes and dishes that have been sitting with dried food on them for awhile.	Pre-wash Rinse Wash (60°C) Hot rinse Drying	5 grams (pre-rinse) 25 grams (main wash)	168 Minutes	1.30	14
Economy (ECO)	For lightly soiled loads, such as plates, glasses, bowls and lightly soiled plates. A standard daily cycle.	Pre-wash Wash (45°C) Hot rinse Drying	5 grams (pre-rinse) 25 grams (main wash)	123 Minutes	0.85	11
Crystal	Eco + Rapid wash, designed for delicate items such as crystal, glass or china which are more sensitive to high temperatures.	Pre-wash Wash (40°C) Hot rinse Drying	5 grams (pre-rinse) 25 grams (main wash)	126 Minutes	0.80	11
Rapid	A shorter wash for lightly soiled loads that do not need drying.	Wash (40°C) Hot rinse	25 grams (main wash)	37 Minutes	0.50	7
Pre-wash (Rinse)	To rinse dishes that you plan to wash later that day.	Rinse		8 Minutes	0.01	4

* The wash program times that are quoted are intended as a guide only. Please note that factors external to the machine, e.g. the temperature of your water supply, your water pressure etc. can affect the time it takes for the wash program to complete.

** NORMAL is the testing program for EN 50242.

Setting a wash program



Make sure that the before first use section has been followed.

- Check whether the appliance needs rinse aid or salt adding to it.
- Pull out the top and bottom baskets, then load them in accordance with the loading instructions.
- Push the top and bottom baskets fully back into position.
- Add detergent.
- Turn the appliance on by using the ON/OFF button.
- ***IMPORTANT: Wait for 5 seconds before pressing the program selection button, otherwise the appliance may not function correctly.***
- Press the program selection button to choose an appropriate wash program for the load that you are washing. The relevant program indicator neon will light to show which program you have selected.
- Close the door firmly, so that you hear the door lock click shut.
- After a few seconds, you will hear the appliance begin to fill with water and the wash program will have started.

Changing the wash program

IMPORTANT: This should only be attempted when the cycle has only just started, otherwise the detergent tablet may have already released or you could have hot water escaping.

- Slightly open the door of the appliance and wait for a minute before fully opening the door.
- Press and hold down the (selected) program selection button for 3 seconds to cancel the wash program. Then use the program selection button to choose the correct wash program.
- Close the door firmly, so that you hear the door lock click shut.
- After about 10 seconds you will hear the appliance begin to fill with water and the wash program will have started.

At the end of a wash program

- When the wash program is finished a buzzer will sound.
- Open the door of the appliance.
- Use the ON/OFF button to switch the dishwasher off.
- Wait a few minutes before unloading the dishwasher to avoid handling the dishes and utensils while they are still not and more susceptible to breakages. They will also dry better.

Adding an item to a wash cycle

IMPORTANT: This should only be attempted when the cycle has only just started, otherwise the detergent tablet may have already released or you could have hot water escaping.

- Slightly open the door of the appliance and wait for a minute before fully opening the door. The cycle will pause.
- Add the item and close the door. The cycle will resume after approximately 10 seconds.

Delay start

- Set your desired wash program as outlined on page 20 - 21.
- Press the delay start button to delay the start of the wash.
- Keep pressing the delay start button until your desired time of delay is displayed (3,6 or 9 hours).
- The maximum amount delay is 9 hours.

Rinse aid and salt indicator neons

- The rinse aid and salt indicator neons on the control panel will let you know when the appliance needs rinse aid or salt adding to it.

- The  neon indicates that you need to add rinse aid to the appliance. You should follow the procedure outlined on page 13.

- The  neon indicates that you need to add dishwasher salt to the appliance. You should follow the procedure outlined on page 11.

Saving energy using your dishwasher

Loading dishes

- Refer to the relevant section of this manual for instructions on placing items in the dishwasher for the most efficient cleaning.
- Only run the dishwasher when it is full for optimum energy and water usage.
- Check the program table to select the most efficient program according to the size and type of the load.
- The ECONOMY program washes your items at a lower temperature and uses less water during the cycle. That is better for the environment and helps to cut energy costs as well as your water bill if you're on a water meter.

Usage

- Clean the filters regularly both to keep the dishwasher clean and to maintain its efficiency.
- Always remember to switch the appliance off standby when you have finished using it. £1 billion worth of energy is wasted in the UK every year by people leaving appliances on standby.
- You do not need to rinse dishes off before loading. If you prefer to pre-rinse, use cold water on your dishes before loading them but do not waste water by letting it run continuously.
- Use the shorter and lower temperature cycles for everything but the dirtiest dishes. Shorter cycles use less energy and work just as well. Modern detergents also work just as well at lower temperatures.



IMPORTANT: *The appliance should be disconnected from your mains supply before commencing any cleaning process.*

The filter system

Your appliance is fitted with three levels of filtering; these are located in the base of the dishwasher for ease of access.

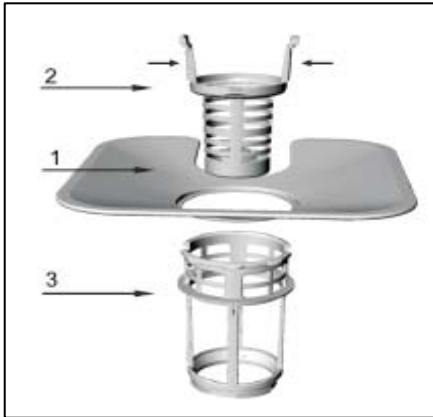

- 1) Main filter
- 2) Coarse filter
- 3) Fine filter

Main filter- Food and soil particles are trapped by this filter and pulverised by a special jet on the lower spray arm. This debris is then washed down the drain.

Coarse filter- Larger items such as pieces of bone or glass, which could clog the drain, are trapped in this filter.

Fine filter- This filter holds soil and food residue in the sump area and prevents it from being redeposited on the dishes during a wash cycle.



IMPORTANT: *Whilst the filtering system is efficient, your dishwasher is not a waste disposal unit. All items being washed inside of the dishwasher should have food scraps removed from them before being loaded into the appliance.*

Cleaning the filters

For best performance and results, the entire filter assembly should be thoroughly cleaned regularly (ideally after each wash cycle).



1. Turn the coarse filter anti-clockwise and then lift it upwards. The fine filter will come out with the coarse filter. Rinse out these sections under a tap to remove any food debris that remains in it.

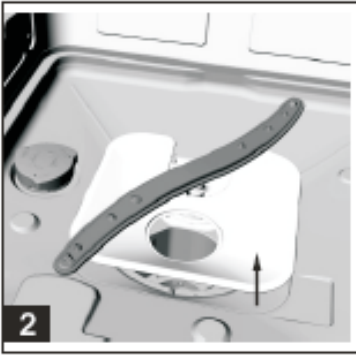

2. Pull out the main filter and rinse this under the tap to remove any food debris that is trapped in it.
3. Place all filters back in their original position.
4. You must turn the coarse filter clockwise to lock it back into position.

IMPORTANT: If a glass gets smashed inside of the appliance, you must check there is no glass in the filter before the machine is used again as this can cause a drainage failure.



IMPORTANT: THE DISHWASHER SHOULD NEVER BE SET ON A WASH CYCLE WITHOUT THE FILTERS BEING INSIDE OF THE APPLIANCE.

Cleaning the spray arms

The spray arms should be cleaned regularly, to prevent hard water deposits from clogging the spray arm jets and bearings.

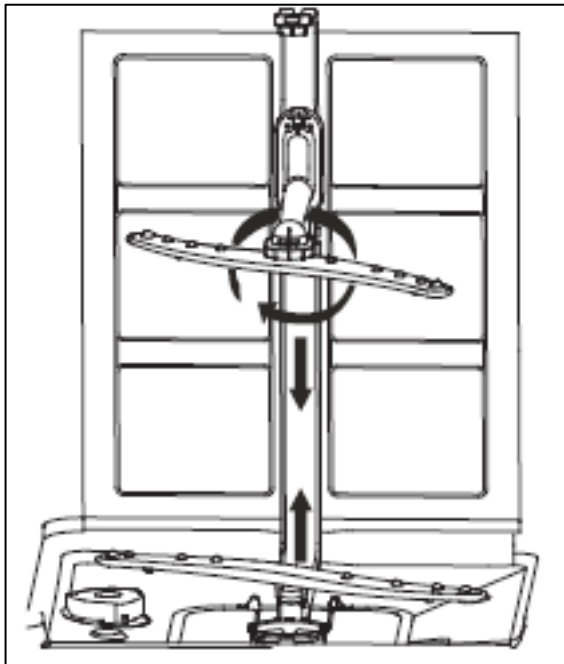

- To remove the top spray arm, unscrew the nut and take out the washer that sits on top of the spray arm and pull to remove.
- Gently pull upwards to remove the bottom spray arm.
- Wash the spray arm in warm, soapy water and use a soft brush to clean the jets.
- Rinse the spray arm thoroughly and then reassemble the spray arm back in its original position.

Cleaning the control panel

IMPORTANT: Do not use any abrasive cleaner or household polish on either the control panel or operating parts.

- Wipe over the control panel using a brand new damp cloth with warm water.

Cleaning the door

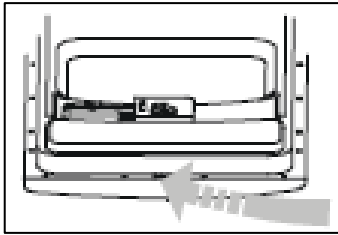

- To clean the edge around the outside of the door, you should use a soft, damp cloth only.
- To prevent water from penetrating the door lock or electrical components, **DO NOT** use a spray cleaner of any kind.
- **DO NOT** use any abrasive cleaner or scouring pads on the inner or outer surfaces, as they may cause damage to them.

Error code failure system

The following error codes (Flashing display neon's) can possibly be remedied by the customer and the maintenance steps outlined below should be followed.

BEFORE COMPLETING ANY MAINTAINANCE ON THE APPLIANCE, IT SHOULD BE DISCONNECTED FROM YOUR MAINS POWER SUPPLY.

Intensive & Crystal wash indicator neon's flash

- Longer than expected fill time.
 - ✓ Check the water pressure of your mains water supply.
 - ✓ Clean the mesh filter that sits in the inlet hose.
 - ✓ Ensure that the inlet hose is not kinked or crushed.
 - ✓ Make sure the water tap that the machine is connected to is turned on fully.

Intensive & Rapid wash indicator neon's flash

- Longer or extended drain time.
 - ✓ The drain pipe may be placed in too high a position or incorrectly. Check the installation instructions and ensure that the installation is correct.
 - ✓ Check that the outlet hose is not kinked or crushed.
 - ✓ Make sure that the drain hose has not been extended beyond its original length.

Normal & Economy wash indicator neon's flash

- The machine has sensed water in the base.
 - ✓ Check that the outlet hose is not kinked or crushed.
 - ✓ Check that there are no blockages in the drain hose or the drainage system that the appliance is connected to.
 - ✓ The drain pipe may be placed in too high a position or incorrectly. Check the installation instructions and ensure that the installation is correct.

Other error codes:

NEON	MEANING	POSSIBLE CAUSES
Intensive + Normal	Door open	The door is open when the dishwasher is operating
Intensive + Pre-Rinse	Temperature sensor	Temperature sensor malfunction
Normal + Crystal	Water leakage	Water leakage occurs
Normal + Pre-Rinse	Heating element	Abnormal heating

IMPORTANT: If any of the above fault codes (flashing neon's on the control panel) appears then you should check the trouble shooting table on page 28-29 for possible solutions. If no solution can be found or an error code not listed is displayed then you should disconnect your appliance from the mains supply and contact customer service immediately.

FOR THE ABOVE FAULT CODES, IF THE CODE REAPPEARS AFTER FOLLOWING THE ADVICE AND CLEARING THE FAULT CODE YOU SHOULD TURN OFF THE APPLIANCE. DISCONNECT THE APPLIANCE FROM YOUR MAINS SUPPLY AND THEN ARRANGE FOR AN ENGINEER TO ATTEND THE APPLIANCE BY CONTACTING THE CUSTOMER CARE DEPARTMENT.

Please note that if an engineer is asked to attend whilst the product is under guarantee and finds that the problem is not the result of an appliance fault, then you may be liable for the cost of the call out charge.

The appliance must be accessible for the engineer to perform any necessary repair. If your appliance is installed in such a way that an engineer is concerned that damage will be caused to the appliance or your kitchen, then he will not complete a repair.

This includes situations where appliances have been tiled in, sealed in with sealant, have wooden obstructions placed in front of the appliance, like plinths. Or any installation other than the one specified by the manufacturer has been completed.

Please refer to the conditions of guarantee that appear on the warranty card that you receive with the appliance.

IMPORTANT: The manufacturer operates a policy of continuous improvement and reserves the right to adjust and modify its products without prior notification.

General troubleshooting

PROBLEM	POSSIBLE CAUSES	WHAT TO DO
<i>Dishwasher doesn't run</i>	<p>Fuse blown or the circuit breaker has tripped</p> <p>Power supply is not switched on</p> <p>Water pressure is low</p>	<p>Replace the fuse or reset the circuit breaker. Remove any other appliances that are sharing the same circuit with the dishwasher.</p> <p>Make sure that the dishwasher is turned on and that the door is closed securely.</p> <p>Make sure that the power cord is fully plugged into the wall socket.</p> <p>Check that the water supply is connected properly and that the water is turned on.</p>
<i>Drain pump doesn't stop</i>	Overflow	The system is designed to detect an overflow. If it does, then it will run the drain pump continuously when there is power to the appliance.
<i>Noise</i>	<p>Some audible sounds are normal</p> <p>Utensils are not secure in the baskets or something small has dropped into the basket</p> <p>Motor hums</p>	<p>You will get a level of operating noise during a wash cycle, in particular when food is being removed from items and when the detergent dispenser places the tablet into the tub.</p> <p>Ensure that everything is loaded as per The manufacturer's loading instructions.</p> <p>If the dishwasher is not going to be used for a period of time, then you should make sure that the appliance is set on a wash program once a week. Otherwise the seal around the motor may dry out and cause noise.</p>
<i>Suds in the tub</i>	<p>Improper detergent use</p> <p>Spilled rinse aid</p>	<p>Ensure if you are using 3 in 1 detergent tablets, in conjunction with rinse aid and salt that the levels are set correctly.</p> <p>Always wipe up any excess rinse aid or rinse aid spillages immediately.</p>
<i>Stained tub interior</i>	Detergent with colourant was used	Use a detergent without colourant.
<i>Dishes are not fully dried</i>	Rinse aid dispenser is empty	Make sure that the rinse aid dispenser is filled with rinse aid.

<i>Dishes and pans are not clean</i>	Improper program Improper loading	<p>Select a more intense wash program.</p> <p>Make sure that the spray arms and the detergent dispenser are not being impeded by large dishes.</p>
<i>Spots and filming on glasses and pans</i>	Extremely hard water Low inlet temperature Improper loading Improper detergent Incorrect salt/rinse aid levels	<p>Refer to the relevant sections of this booklet, to ensure that the detergent, salt and rinse aid levels are set correctly. Ensure that the appliance is loaded correctly.</p>
<i>Steam</i>	A normal phenomenon	<p>You may get a small amount of steam coming through the vent by the door latch, during drying and water draining.</p>
<i>Black or grey marks on dishes</i>	Aluminium utensils have rubbed against dishes	<p>Use a mild abrasive cleaner to eliminate the marks. Make sure that the appliance is loaded correctly in future.</p>
<i>Water standing in the bottom of the tub</i>	This is normal	<p>A small amount of clean water in the base of the appliance is not something to be concerned about.</p>
<i>Dishwasher leaks</i>	The rinse aid dispenser is overfilled or rinse aid has been spilt inside the appliance Dishwasher isn't level	<p>Take care not to overfill the rinse aid dispenser. Spilt rinse aid could cause oversudsing and lead to overflowing. Wipe away any spills immediately with a damp cloth.</p> <p>Make sure that the dishwasher is level.</p>

Installation



IMPORTANT: THIS INSTALLATION MUST BE COMPLETED BY A SUITABLY QUALIFIED PERSON. THE MANUFACTURER ONLY SANCTIONS THE INSTALLATION GIVEN IN THIS INSTRUCTION MANUAL. YOU SHOULD DISPOSE OF ALL PACKAGING IN AN ENVIRONMENTALLY FRIENDLY MANNER.

Connecting to the mains water supply



IMPORTANT: Do not connect the appliance to your mains water supply using an old or an existing water inlet hose. The inlet hose supplied with the dishwasher is the **ONLY** one that should be used.

DO NOT CONNECT THE WATER INLET HOSE TO A HOT WATER TAP.

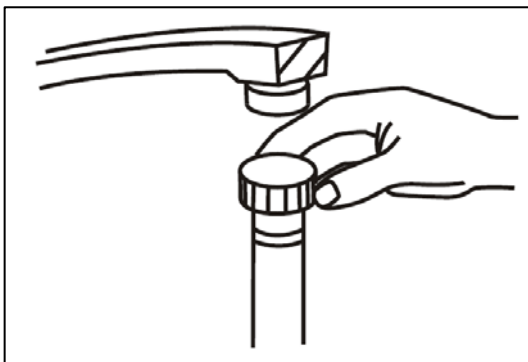

- Before connection, we would advise running the water to ensure that it is clear and free from impurities as dirty water could block the inlet pipe and damage the machine.
- The inlet hose will be located inside the cavity of the dishwasher.
- Connect the water inlet hose to a threaded water tap that has a 3/4" thread and to the inlet hose connector on the appliance.
- Fully tighten the inlet hose to the water tap and the dishwasher.

Connecting to the water outlet

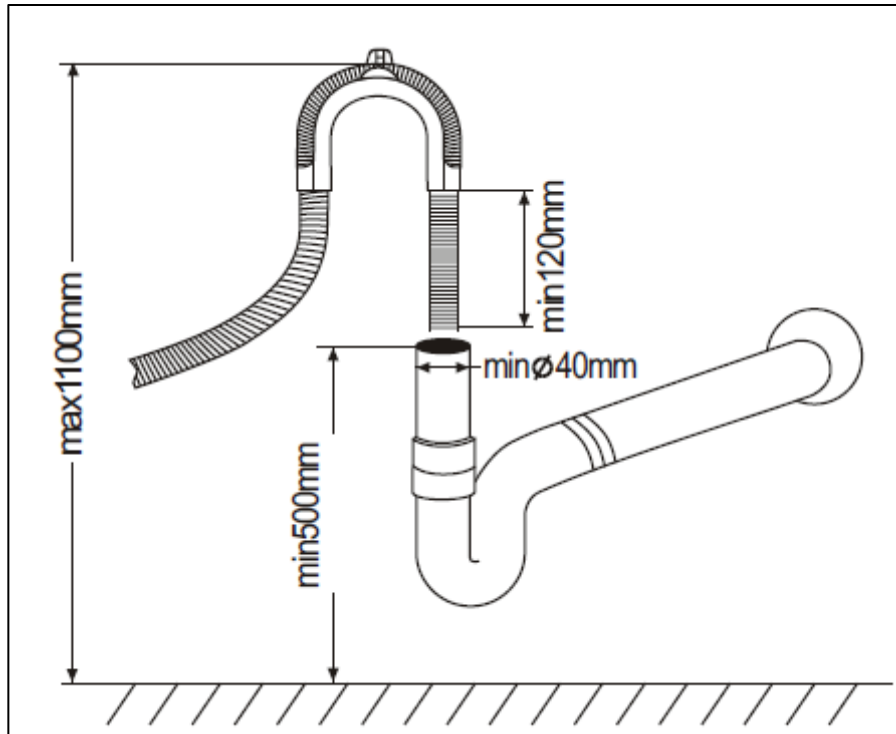

- Secure the drain hose, so that it cannot move whilst the dishwasher is in use.
- Place the end of the drain hose in your drain pipe and push it a short way down (min 120mm)
- **IMPORTANT:** Do not insert the drain hose too deeply into the pipe, as this may cause siphoning.
- **NEVER EXTEND THE DRAINAGE HOSE FROM ITS ORIGINAL LENGTH.**

Connecting to the power supply

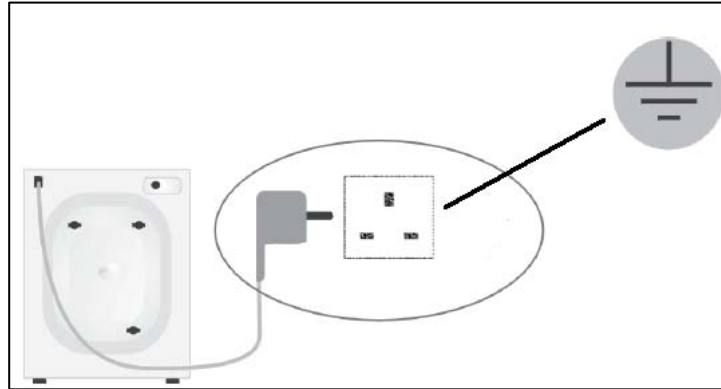

- **IMPORTANT:** The electrical socket must still be accessible once the appliance is installed.

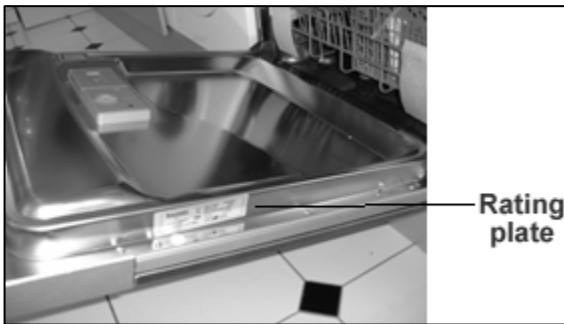

- Consult the rating plate, located on the right hand side of the drop down door **BEFORE** making the electrical connections. Ensure that the voltage reaching the plug is the same as that on the rating plate.
- **DO NOT REMOVE THE RATING PLATE AS THE INFORMATION ON IT IS IMPORTANT.**
- The moulded plug that is supplied with the appliance must be placed into an earthed and insulated socket.
- Broken or damaged power leads must only be replaced by a suitably qualified person. A power lead of a similar type must be used in replacement.
- Power lead type – H 0 V V – F 3G 1,5.
- **IMPORTANT:** We do not recommend that this appliance is connected to an extension lead.

Levelling the appliance

- **IMPORTANT:** Your dishwasher must be level for it to operate properly.



- Make sure that the dishwasher is supported whilst it is being levelled, otherwise it may tip over.



- The feet can be adjusted using a spanner.



- Use a spirit level to check that the appliance is level.
- Check that the appliance is level from side to side.
- Check that the appliance is level from front to back.

Before first use

You should check the following before using the appliance for the first time: -

- That the dishwasher is level and fixed in position.
- That the water tap is fully open.
- That there are no leaks at either end of the drain or inlet hoses.
- That the inlet and outlet hose are fully tightened.
- That the inlet and outlet hoses are not kinked.
- That the power is switched on.
- That the water softener has been filled with 500ml of water and salt.
- That the rinse aid dispenser has been filled.

Technical Data

Manufacturer	BAUMATIC
Model Number	BDWF60W
Standard Place Settings	12
Energy Efficiency Class (1)	A+
Annual Energy Consumption (2)	289 kWh
Energy Consumption of the Standard Cleaning Cycle	1.03 kWh
Power Consumption of Off Mode	0.10 W
Power Consumption of Left-On Mode	0.49 W
Annual Water Consumption (3)	3920 litres
Drying Efficiency Class (4)	A
Standard Cleaning Cycle (5)	Normal 50°C
Program Duration of the Standard Cleaning Cycle	153 mins
Noise Level	49 dB
Installation Type	Freestanding

(1) On a scale from A+++ (highest efficiency) to D (lowest efficiency).

(2) Annual energy consumption based on 280 standard cleaning cycles using cold water fill and the consumption of the low power modes. The actual energy consumption will depend on how the appliance is used.

(3) Annual water consumption based on 280 standard cleaning cycles. The actual water consumption will depend on how the appliance is used.

(4) On a scale from A (highest efficiency) to G (lowest efficiency).

(5) This program is suitable for cleaning normally soiled tableware and is the most efficient program in terms of combined energy and water consumption.



United Kingdom

Baumatic Ltd.,
Baumatic Buildings,
6 Bennet Road,
Reading, Berkshire
RG2 0QX
United Kingdom

Sales Telephone

(0118) 933 6900

Sales Fax

(0118) 931 0035

Customer Care Telephone

(0118) 933 6911

Customer Care Fax

(0118) 986 9124

Spares Telephone

(01235) 437244

Advice Line Telephone

(0118) 933 6933

E-mail:

sales@baumatic.co.uk
customercare@baumatic.co.uk
spares@baumatic.co.uk
technical@baumatic.co.uk

Website:

www.baumatic.co.uk

Facebook:

www.facebook.com/baumatic.uk

Republic of Ireland

Service Telephone

1-890 812 724

Spares Telephone

091 756 771

Czech Republic

Baumatic CR spol s.r.o.
Lípová 665
460 01 Liberec 4
Czech Republic

+420 483 577 200

www.baumatic.cz

Slovakia

Baumatic Slovakia, s.r.o.
Panenská 34
811 03 Bratislava - Staré Mesto
Slovakia

+421 255 640 618

www.baumatic.sk

Germany

Baumatic GmbH
Bachstr.10-12
D-32 257 Bünde
Deutschland

+49 (0) 5223 99408 0

www.baumatic.de

Italy

Baumatic Italia S.R.L.
Via Galvani N.3
35011 Campodarsego (PD)

+3904 9920 2297

www.baumatic.it

Holland

Baumatic Benelux B.V.
Dukdalfweg 15d
1332 BH ALMERE
Nederland

+31(0)36 549 1553

www.baumatic.nl

