

Capella - 2 Drawer 4 Door Robe

Assembly Instructions - Please keep for future reference

266/0709

248/4112

266/9683

241/5844

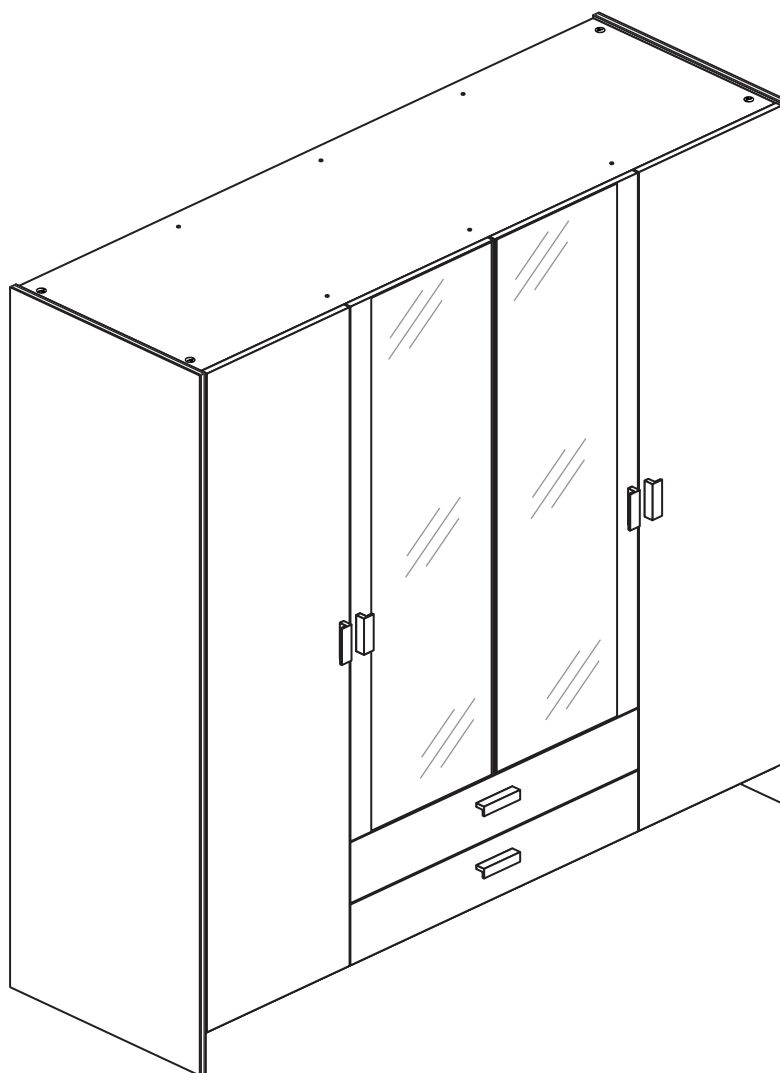

Dimensions

Width - 152cm

Depth - 49cm

Height - 181cm



**MADE IN
BRITAIN**

Important - Please read these instructions fully before starting assembly

If you need help or have damaged or missing parts, call the **Customer Helpline: 08456 400800**



Safety and Care Advice

Important - Please read these instructions fully before starting assembly

- **Warning:** This unit weighs approximately 96kgs. Please lift with care.
- Check you have all the components and tools listed on pages 2 and 3.
- Remove all fittings from the plastic bags and separate them into their groups.
- Keep children and animals away from the work area, small parts could choke if swallowed.
- Parts of the assembly will be easier with 2 people.

- Make sure you have enough space to layout the parts before starting.
- Do not stand or put weight on the product, this could cause damage.
- Assemble the item as close to its final position (in the same room) as possible.
- Assemble on a soft level surface to avoid damaging the unit or your floor (use opened out unit carton).



- We do not recommend the use of power drill/drivers **for inserting screws**, as this could damage the unit. Only use hand screwdrivers.







- **Safety note:** It is recommended that this unit is secured to a wall using the bracket supplied.

- Dispose of all packaging carefully and responsibly.

Care and maintenance

- Only clean using a damp cloth and mild detergent, do not use bleach or abrasive cleaners.
- From time to time check that there are no loose screws on this unit.
- This product should not be discarded with household waste. Take to your local authority waste disposal centre.

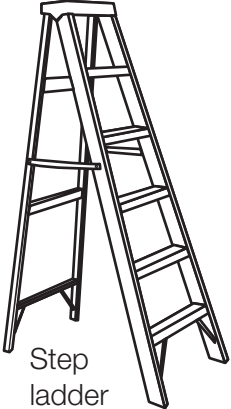
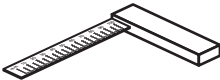
Tools required

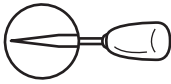
 Rule	 Spirit level	 Eye protection (when using a hammer or drill)	 Cross-head screwdriver	 Electric drill (only use when drilling into walls)	 Step ladder
 Square	 Scissors	 Hammer	 Bradawl		

Note: If required the next page can be cut out and used as reference throughout the assembly. Keep this page with these instructions for future reference.

Components - Panels

If you have damaged or missing components, call the **Customer Helpline: 08456 400800** quoting the reference numbers below

Please check you have all the panels listed below

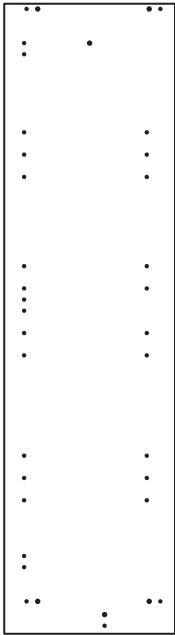

1 Left Side (D1013A)
(1808 x 490mm)

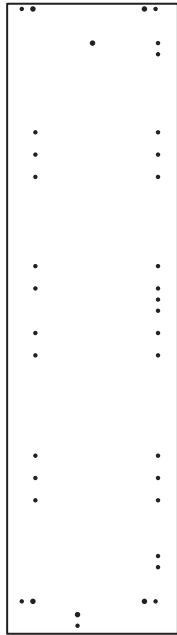

2 Right Side (D1014A)
(1808 x 490mm)

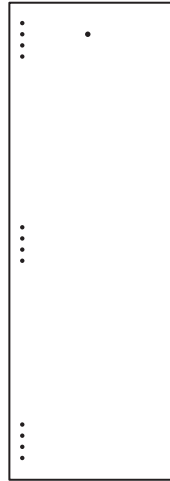

3 Centre Divider (D1028A)
(1369 x 470mm)



4 Top (D1026A)
(1491 x 471mm)

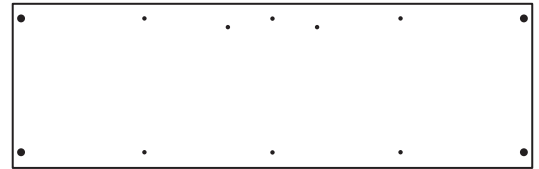

5 Base (D1111C)
(1491 x 471mm)

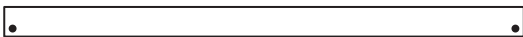

6 Plinth (D1032A)
(1491 x 85mm)

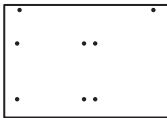

7 Short Divider (D1027A)
(323 x 470mm) x 2

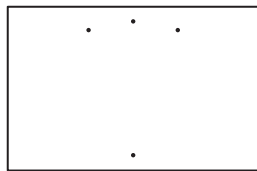

8 Fixed Shelf (D1029C)
(720 x 470mm)

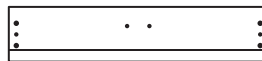

9 Drawer Front (D1031A)
(743 x 157mm) x 2



10 Mirror Door (D1030A)
(1381 x 369mm) x 2
(Mirror - SG14
1376 x 311mm
4mm Safety Back SAR)

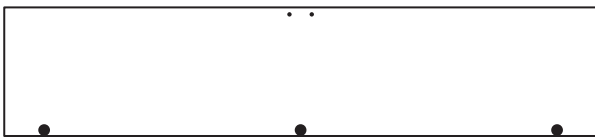

11 Large Door (D1017A)
(1701 x 369mm) x 2

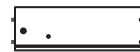

12 Left Drawer Side (W370-124LH)
(370 x 124mm) x 2



13 Right Drawer Side (W370-124RH)
(370 x 124mm) x 2



14 Drawer Back (W688-124BK)
(688 x 124mm) x 2



15 Drawer Base (T699-367)
(699 x 367mm) x 2

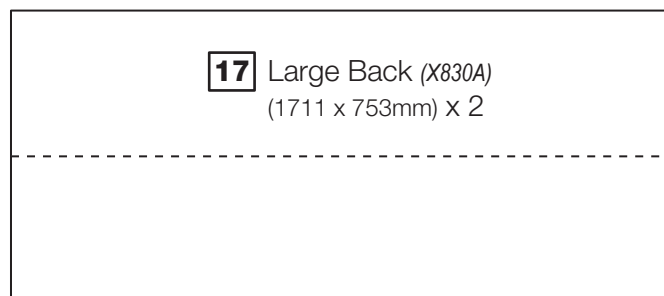

17 Large Back (X830A)
(1711 x 753mm) x 2

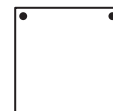

18 Drawer Support (D1397A)
(302 x 302mm)



16 Hanging Rail (FHR728)
(728mm long) x 2











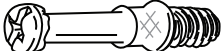
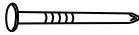









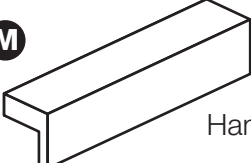
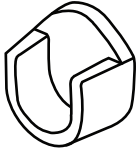
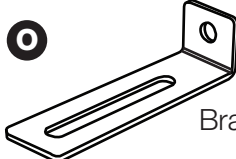

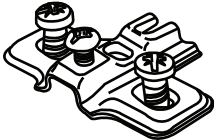
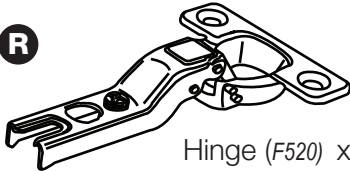
Components - Fittings

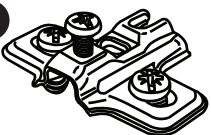
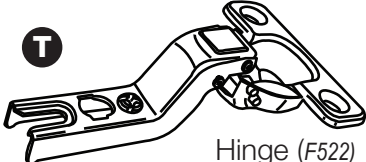
If you have damaged or missing components, call the **Customer Helpline: 08456 400800** quoting the reference numbers below

Please check you have all the fittings listed below

Note: The quantities below are the correct amount to complete the assembly. In some cases more fittings may be supplied than are required.

<p>A </p> <p>Wooden dowel (F22) x 10</p>	<p>B </p> <p>Metal dowel (F901) x 16</p>	<p>C </p> <p>Nail (F51) x 48</p>
<p>D </p> <p>Large locking nut (F900) x 12</p>	<p>E </p> <p>Small locking nut (F3) x 4</p>	<p>F </p> <p>Knock-in Peg (F171GY) x 8</p>
<p>G </p> <p>40mm Screw (F910) x 14</p>	<p>H </p> <p>25mm Screw (F50) x 12</p>	<p>I </p> <p>13mm Screw (F79) x 1</p>
<p>J </p> <p>13mm Screw (F63) x 24</p>	<p>K </p> <p>9mm Screw (F74) x 4</p>	<p>L </p> <p>9mm Screw (F73) x 8</p>
<p>M </p> <p>Handle (F930) x 6</p>	<p>N </p> <p>Rail holder (F1014) x 4</p>	<p>O </p> <p>Bracket (F327) x 1</p>
<p>P </p> <p>Drawer runner (F1004) x 4</p>		
<p>Q </p> <p>Hinge Plate (F521) x 6</p>	<p>R </p> <p>Hinge (F520) x 6</p>	
<p>S </p> <p>Hinge plate (F523) x 6</p>	<p>T </p> <p>Hinge (F522) x 6</p>	
<p>U </p> <p>Wedgfix (F639) x 8</p>	<p>V </p> <p>Plastic Nail (F91) x 5</p>	<p>W </p> <p>Nail screw (F277) x 6</p>
<p>X </p> <p>Back holder (F276) x 6 *These can also be round</p>		

Ruler - Use this ruler to help correctly identify the screws

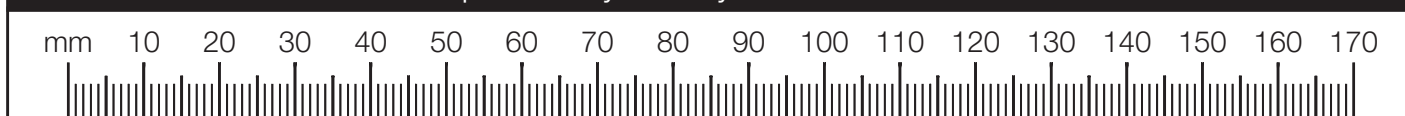

Assembly Instructions

If you have damaged or missing components, call the
Customer Helpline: 08456 400800 quoting the reference
numbers below

Step 1

Prepare the drawer fronts

Screw 2 metal dowels **B** into the holes shown on the back of each drawer front **9**.

Note: Tighten the metal dowels up fully against the panels.

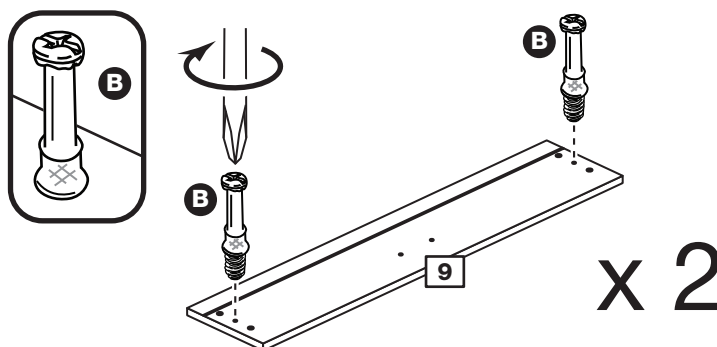

Step 2

Prepare the drawer sides

Insert a small locking nut **E** into the hole shown on the left drawer side **12** and right drawer side **13**.

Note: The arrow on the locking nut **must** point towards the hole in the edge of the panel.

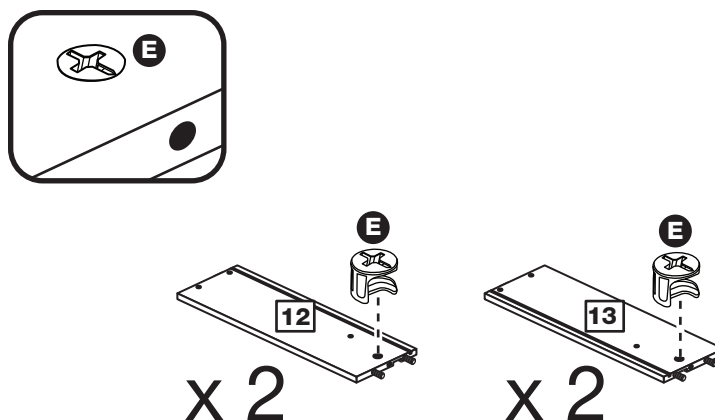

Note: Due to the manufacturing process, the holes for the locking nut can be on either surface of the drawer sides.

Step 3

Attach the drawer sides to the drawer fronts

Push the left drawer sides **12** and right drawer sides **13** onto the back of the drawer fronts **9**.

Turn the small locking nuts **E** on the left drawer side **12** and right drawer side **13**.

Note: Turn the locking nuts **E** clockwise to secure panels - more than 1/2 a turn.

Note: The locking nuts can be on either surface of the drawer sides. Make sure that the small groove is on the inside, as shown.

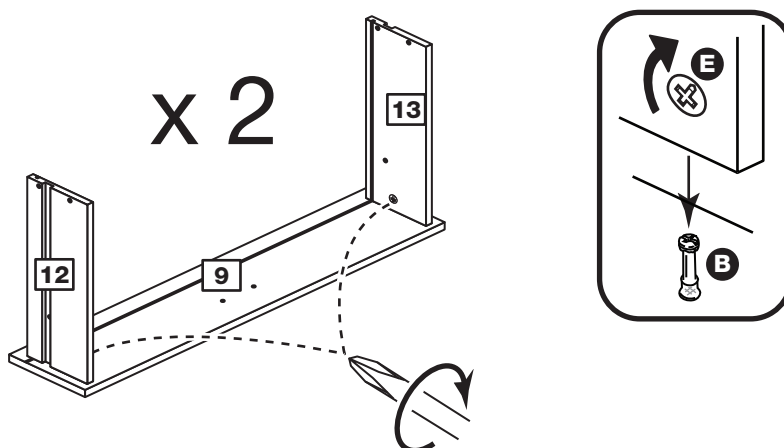

Assembly Instructions

Step 4

Fit the drawer base

Slide the drawer base **15** down the grooves in the drawer sides **12** and **13** and down into the groove in the drawer front **9**.

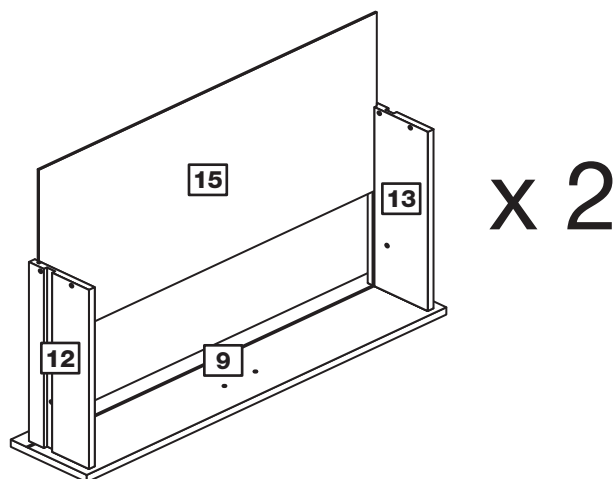

Step 5

Fit the drawer back

Fit the drawer back **14** between the drawer sides **12** and **13**.

Make sure that the drawer base **15** fits into the groove in the drawer back **14**.

Hold the drawer back **14** in position and tap the knock-in pegs **F** through the holes in the drawer sides **12** and **13**.

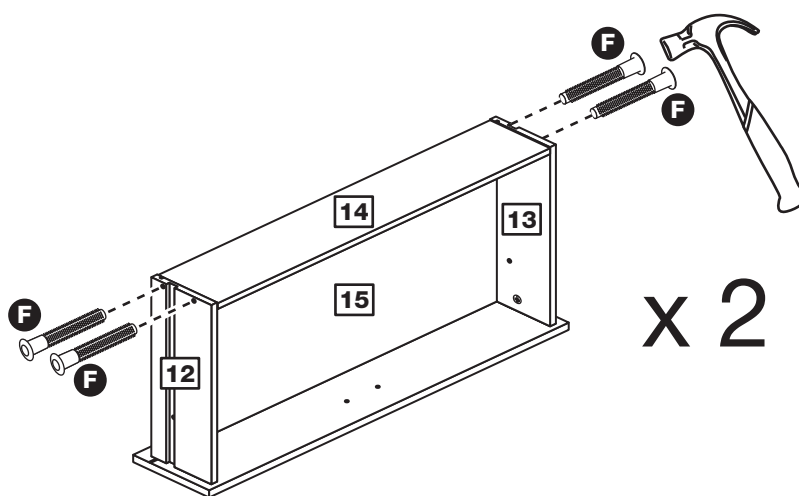

Step 6

Attach the handle

Attach a handle **M** to each drawer front **9** using 2 screws **H**.

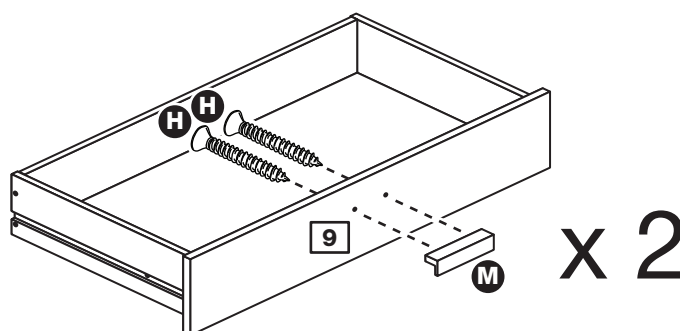

Step 7

Fit the wedgifixes

Turn the 2 drawer assemblies over and slide 4 wedgifixes **U** into the front and back grooves, as shown, and tighten up the screws.

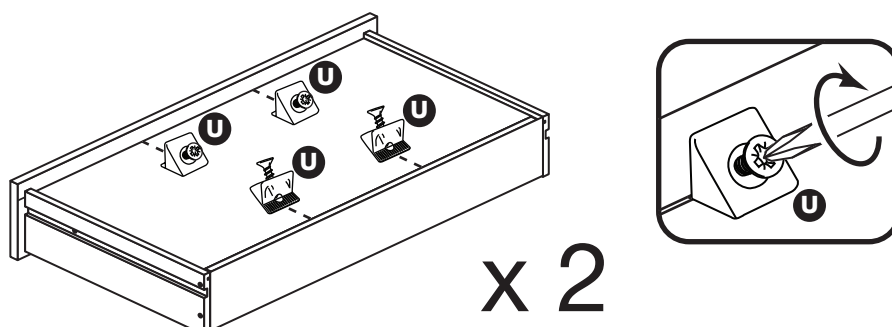

Assembly Instructions

Step 8

Prepare a short divider

a: Place 2 runners **P** on a short divider **7**. Slide back top of runner and use 1st hole from the front to fit 1st screw **L**.

b: Slide runner back the other way and use 3rd hole from the back to fit 2nd screw **L**.

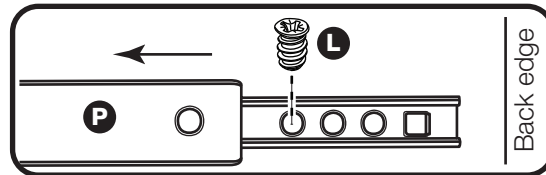
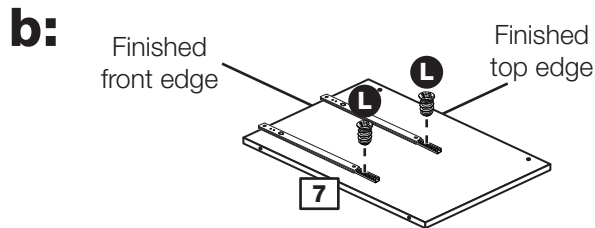
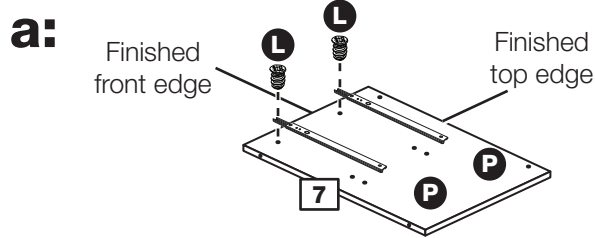
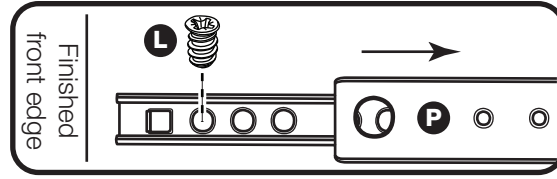

Step 9

Prepare the other short divider

a: Place 2 runners **P** on a short divider **7**. Slide back top of runner and use 1st hole from the front to fit 1st screw **L**.

b: Slide runner back the other way and use 3rd hole from the back to fit 2nd screw **L**.

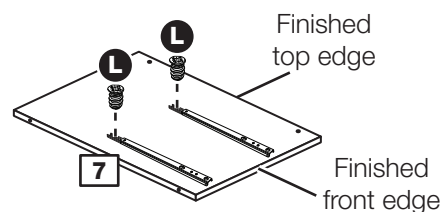
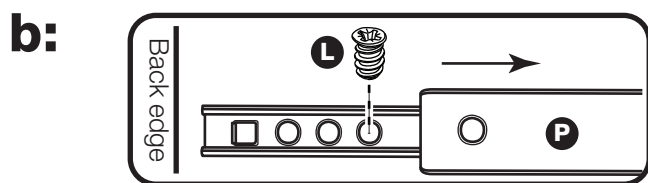
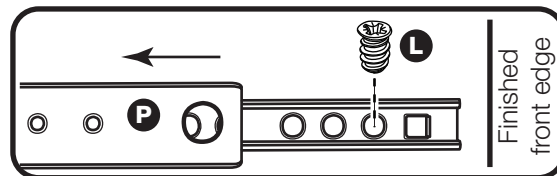
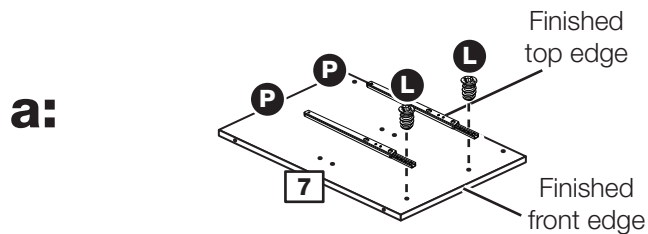

Assembly Instructions

Step 10

Prepare the fixed shelf

Screw 2 metal dowels **B** into the fixed shelf **8**.

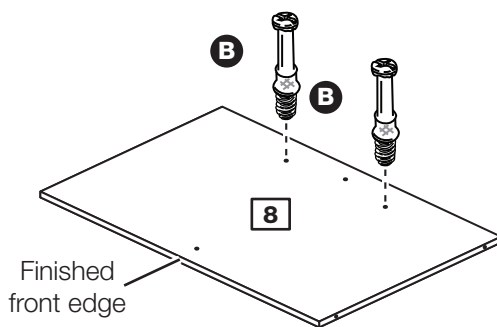

Step 11

Join the short dividers to the fixed shelf

Attach the 2 short dividers **7** to the fixed shelf **8** using 4 screws **G**.

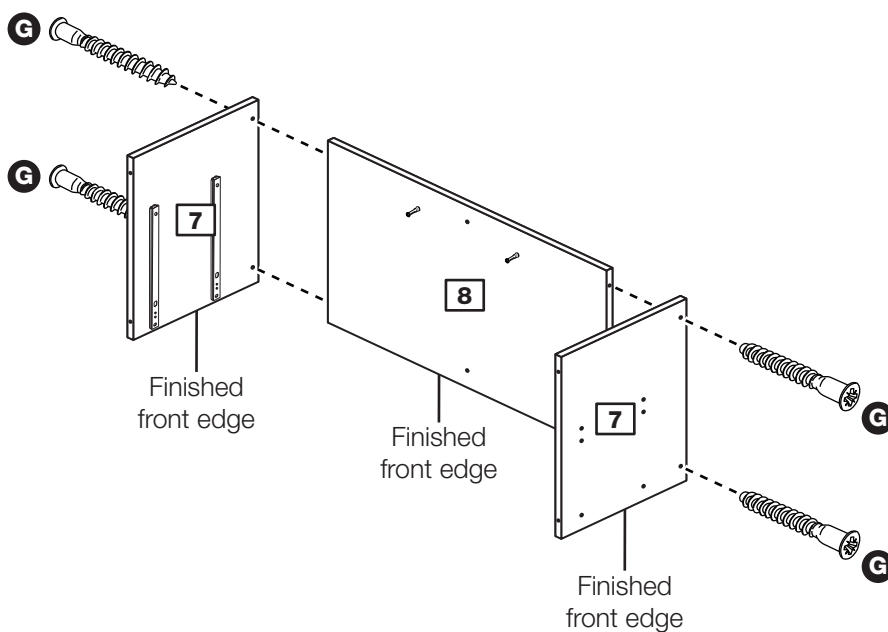

Assembly Instructions

Step 12

Prepare the centre divider

Important: The hinge plates **Q** used in this step are in the bag marked as **AHP0826**.

Fit 3 hinge plates **Q** to the centre divider **3** as shown, making sure that the slot is facing towards the finished front edge.

Push a rail holder **N** into the centre divider **3**. Make sure that it is fitted straight, in line with the panel edges.

Turn the centre divider over

Fit 3 hinge plates **Q** to the other surface of the centre divider **3** as shown, making sure that the slot is facing towards the finished front edge.

Push another rail holder **N** into the centre divider **3**.

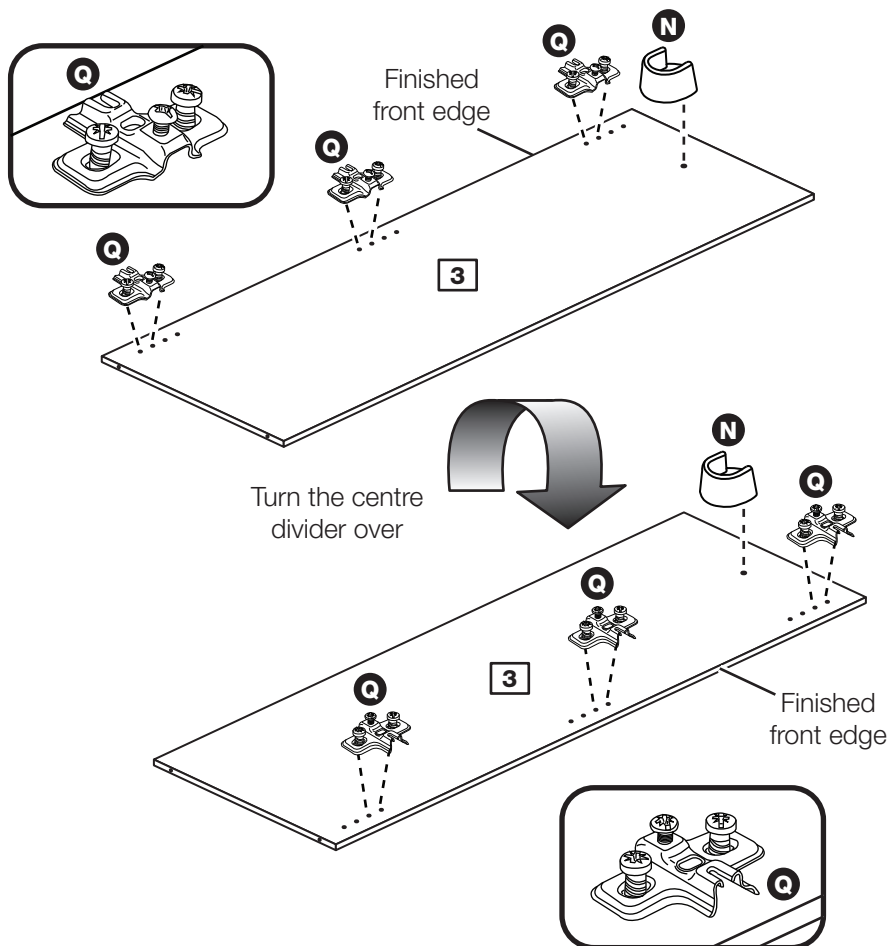
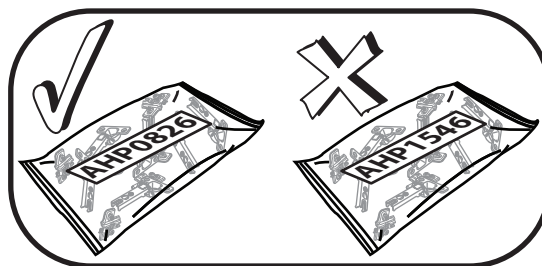

Step 13

Fit the centre divider

Attach the centre divider **3** to the fixed shelf **8** using 2 screws **G**.

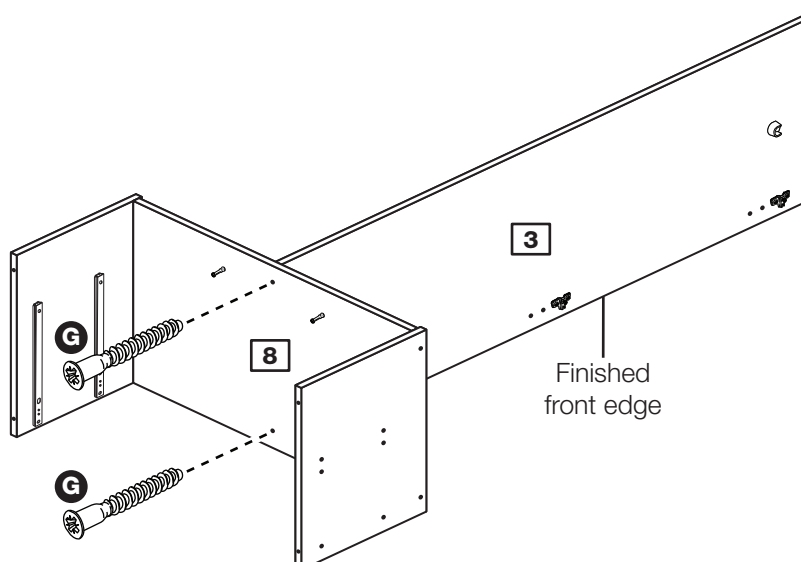

Assembly Instructions

Step 14

Prepare the drawer support

Insert 2 large locking nuts **D** into the drawer support **18**.

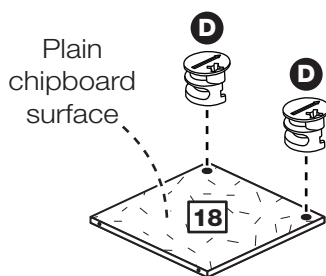

Note: Due to the manufacturing process, the drawer support may either have 1 or 2 plain chipboard surfaces.

Step 15

Prepare the top and base

a: Tap 4 wooden dowels **A** into the top **4**.

Note: Wooden dowels **must not** stick out from the edge by more than 10mm or they may damage other panels.

Insert 4 large locking nuts **D** into the top **4**.

Note: The arrow on the locking nut **must** point towards the hole in the edge of the panel.

b: Tap 4 wooden dowels **A** into the base **5**.

Insert 4 large locking nuts **D** into the base **5**.

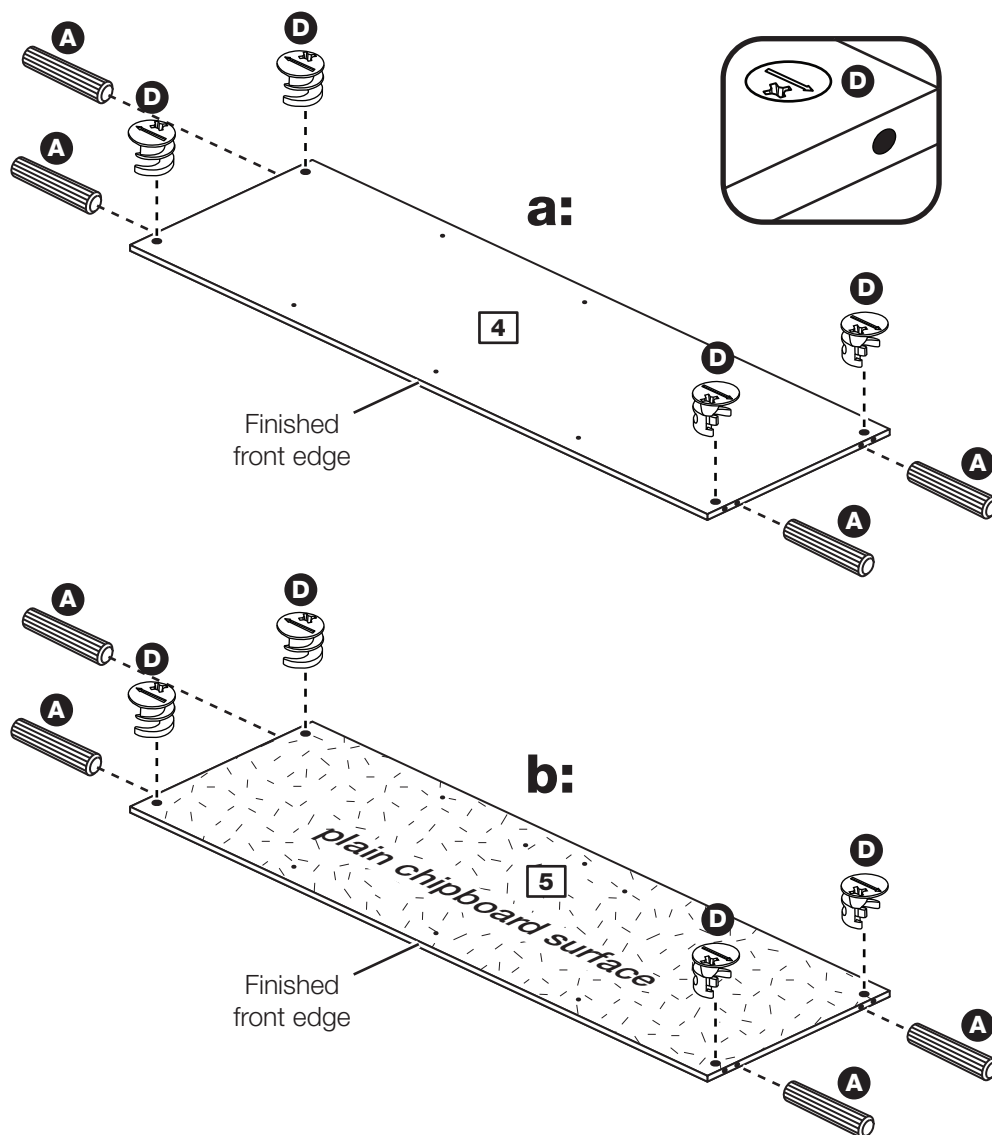

Assembly Instructions

Step 16

Fit the drawer support

Push the drawer support **18** onto the metal dowels **B** fitted to the fixed shelf **8**.

Use a screwdriver to tighten the 2 large locking nuts **D** fitted to the drawer support **18**.

Note: Turn the large locking nuts **D** as far as they will go - more than 1/2 a turn.

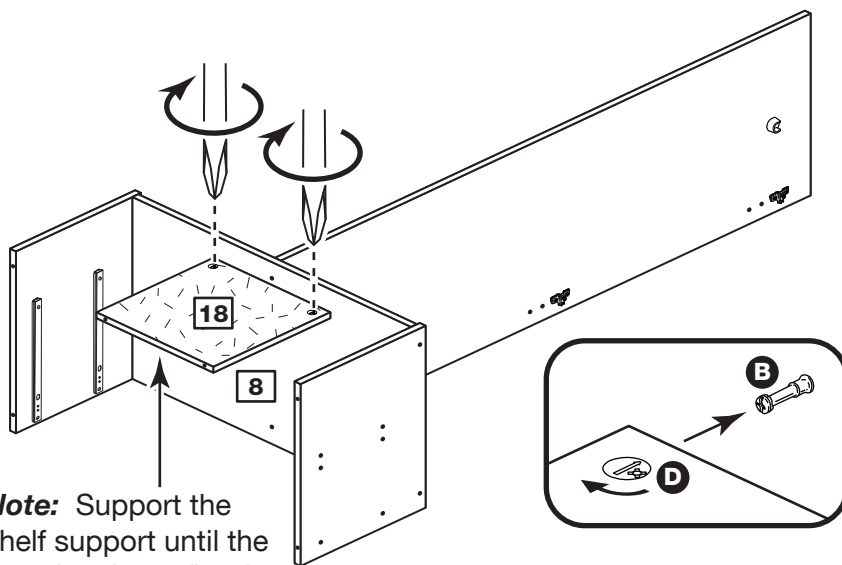

Note: Support the shelf support until the base has been fitted in the next step.

Step 17

Fit the base

Attach the base **5** to the short dividers **7** and drawer support **18** using 6 screws **G**.

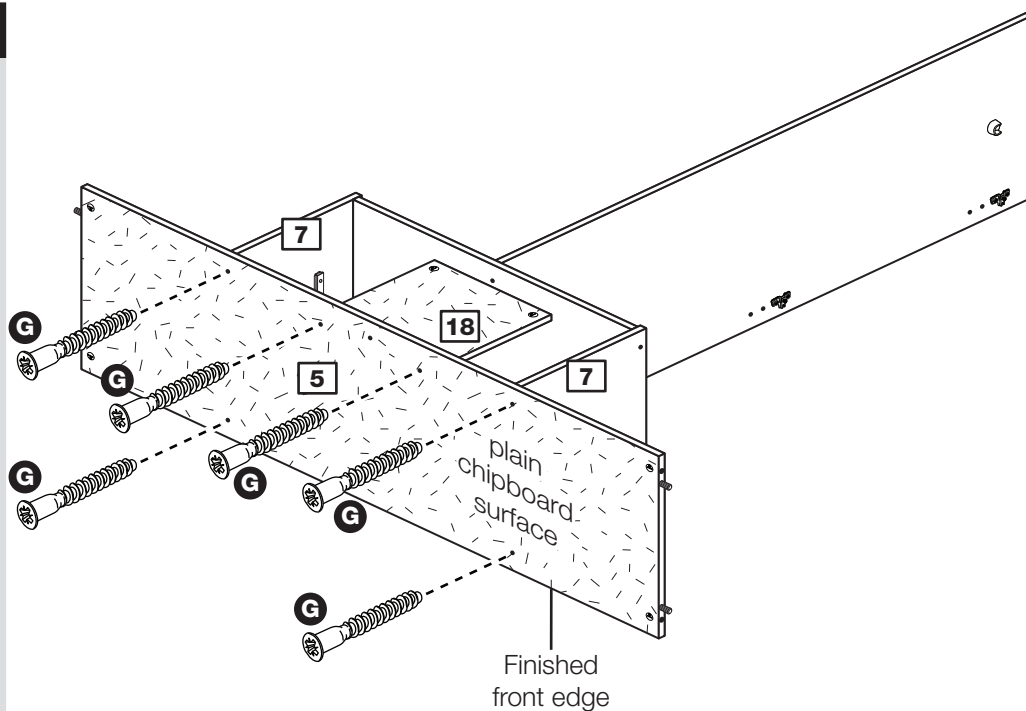

Assembly Instructions

Step 18

Fit the top

Attach the top **4** to the centre divider **3** using 2 screws **G**.

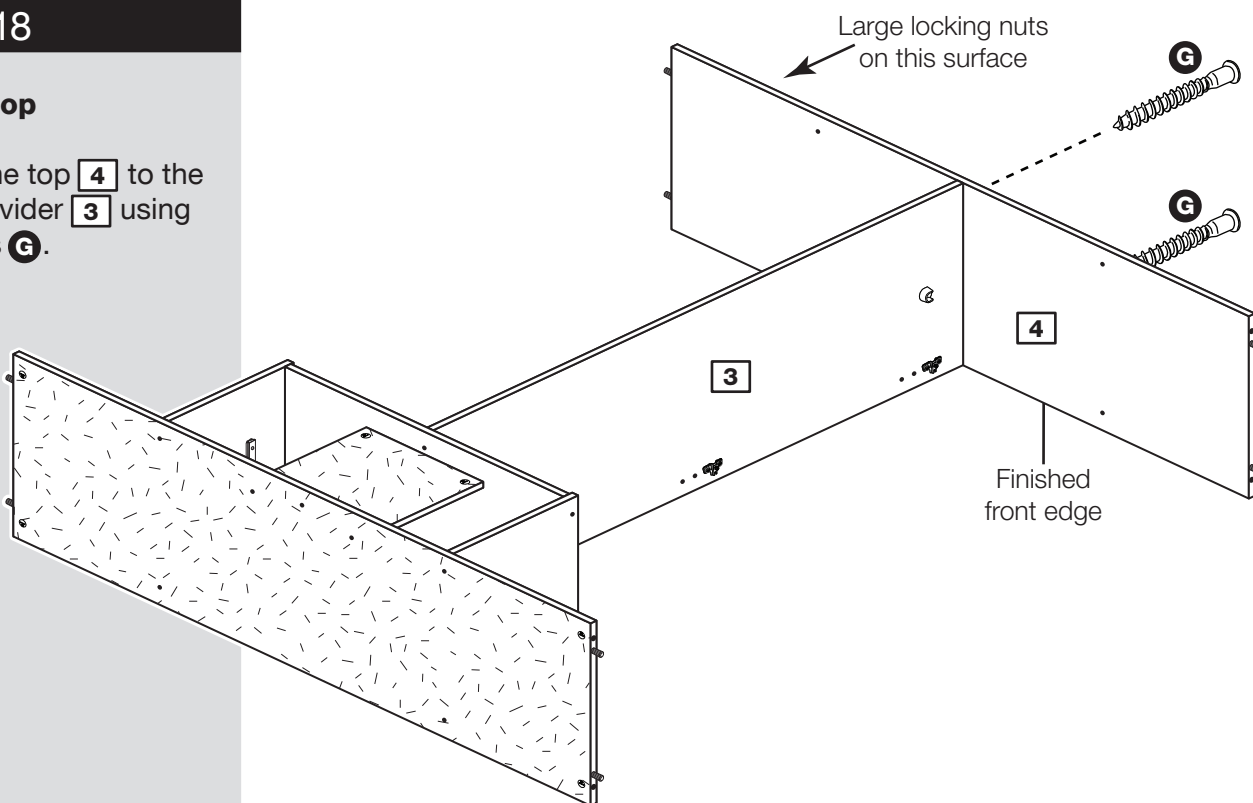

Step 19

Prepare the left side

Important: The hinge plates **S** used in these 2 steps are in the bag marked as **AHP1546**.

Fit 3 hinge plates **S** onto the left side **1**, making sure that the slot is facing towards the finished front edge.

Screw 5 metal dowels **B** into the left side **1**.

Note: Tighten the metal dowels up fully against the panels.

Push a rail holder **N** into the left side **1**. Make sure that it is fitted straight, in line with the panel edges.

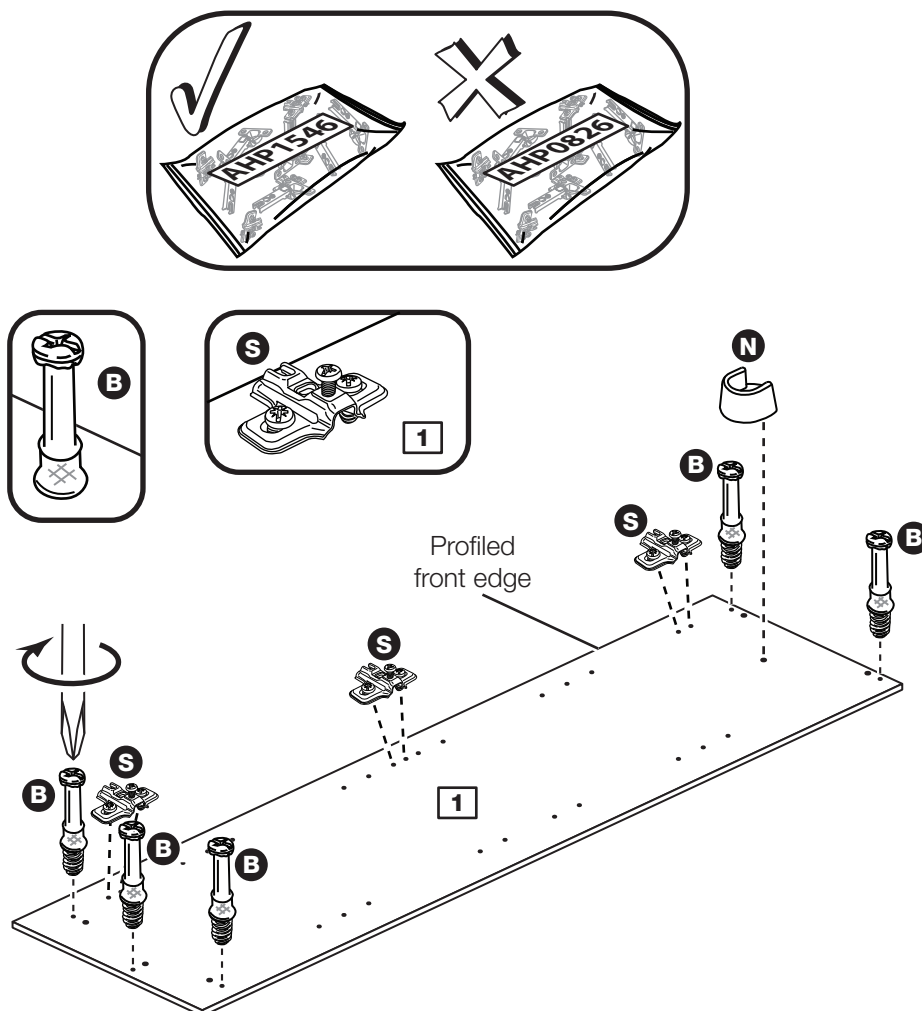

Assembly Instructions

Step 20

Prepare the right side

Fit 3 hinge plates **S** onto the right side **2**, making sure that the slot is facing towards the finished front edge.

Screw 5 metal dowels **B** into the right side **2**.

Note: Tighten the metal dowels up fully against the panels.

Push a rail holder **N** into the right side **2**. Make sure that it is fitted straight, in line with the panel edges.

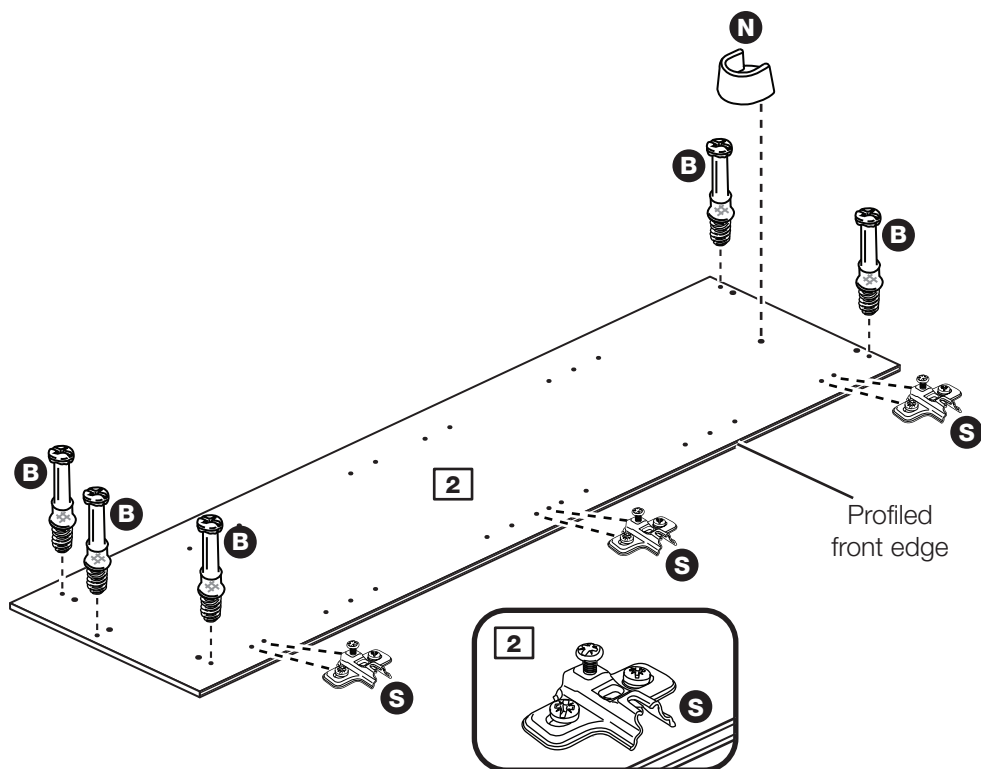

Step 21

Fit the right side

Push the right side **2** onto the top **4** and base **5** as shown.

Use a screwdriver to tighten the 4 large locking nuts **D** fitted to the top **4** and base **5**.

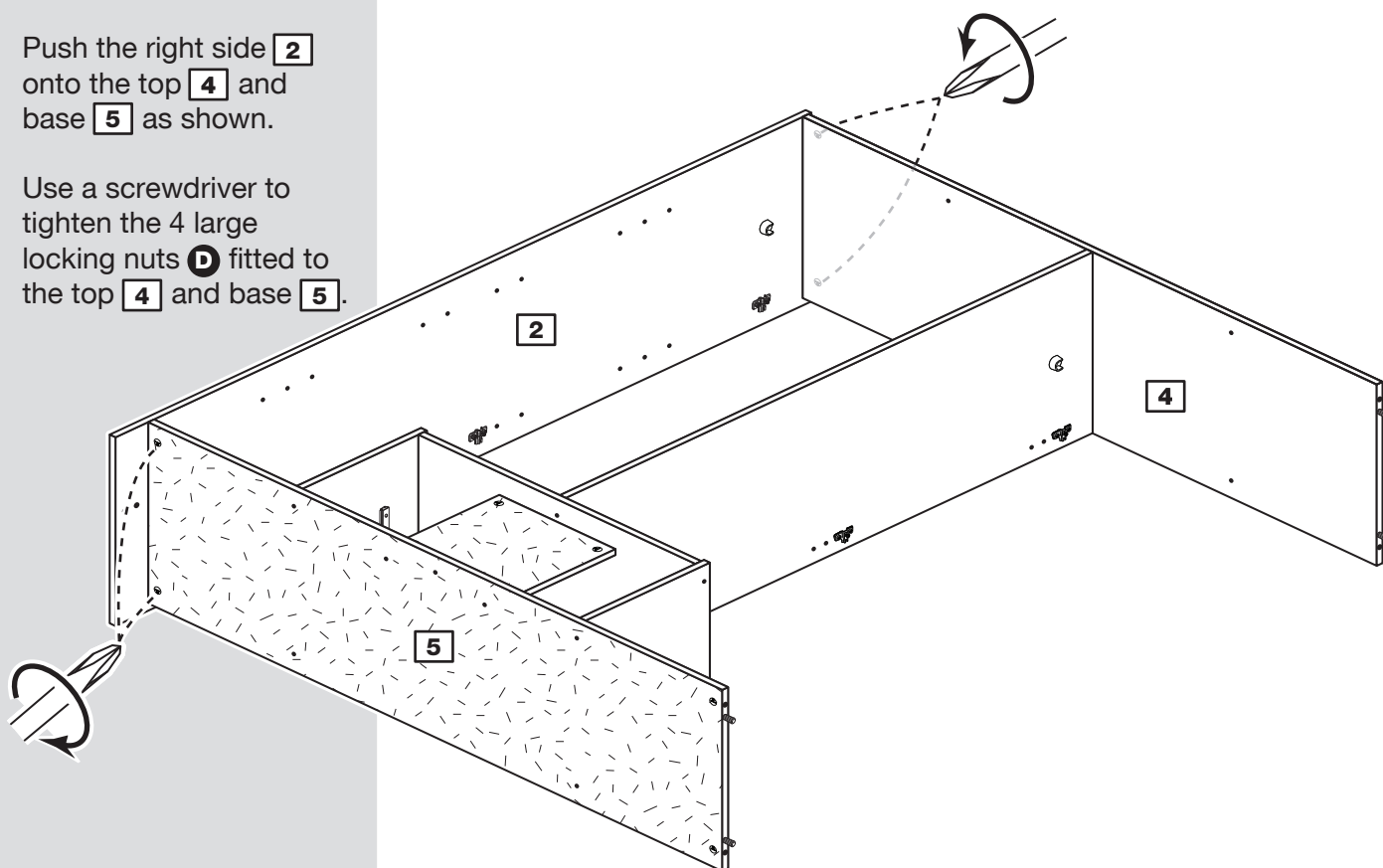

Assembly Instructions

Step 22

Prepare the plinth

Tap 2 wooden dowels **A** into the plinth **6**.

Insert 2 large locking nuts **D** into the plinth **6**.

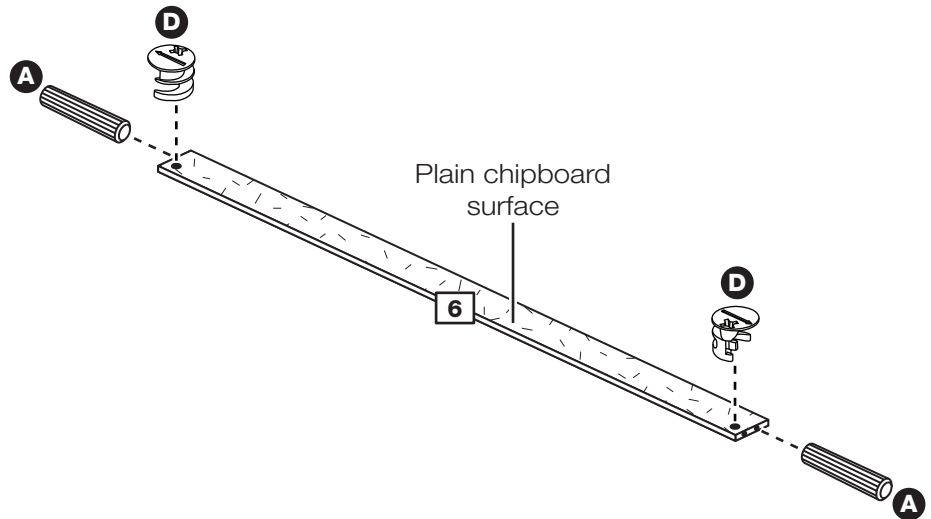

Step 23

Fit the plinth

Push the plinth **6** onto the right side **2** as shown.

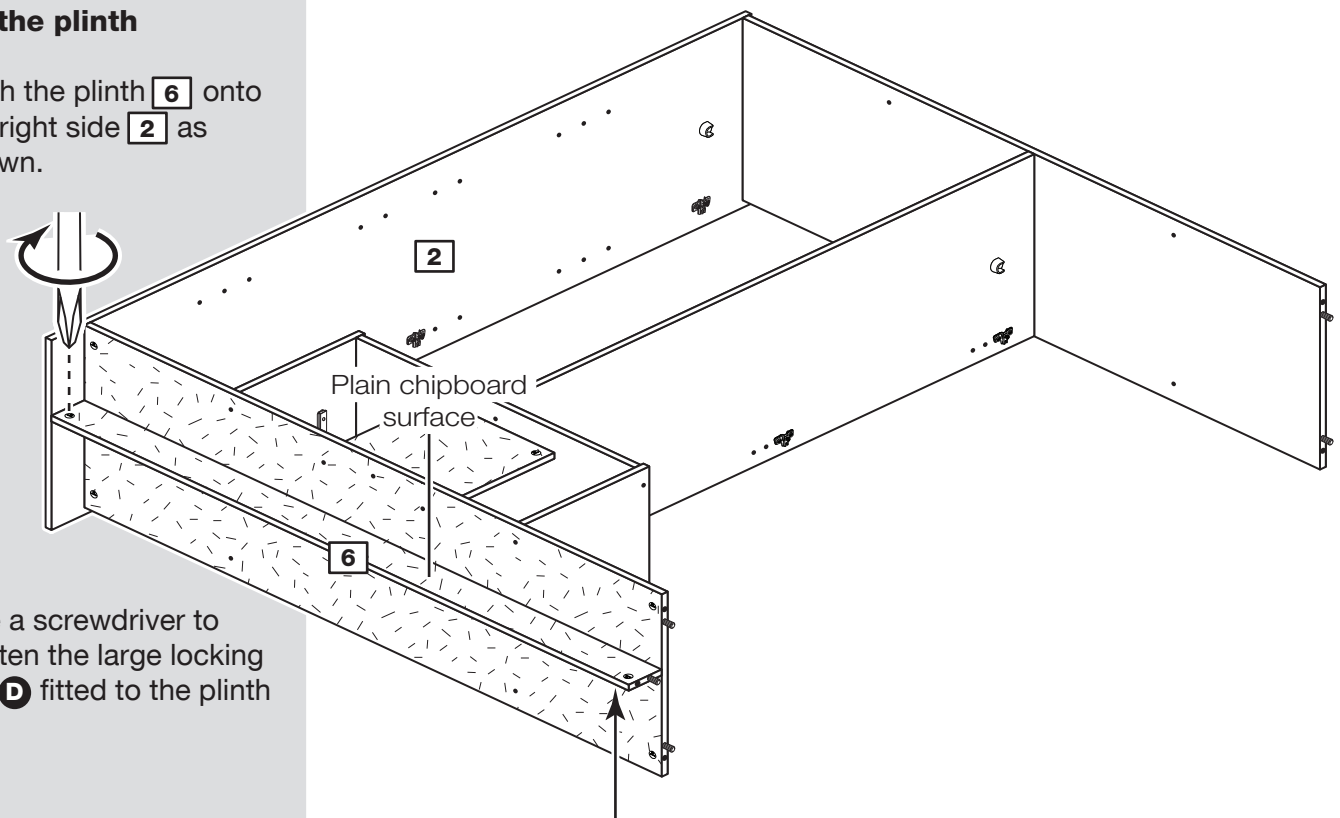

Use a screwdriver to tighten the large locking nut **D** fitted to the plinth **6**.

Note: Support the plinth until the left side has been fitted in the next step.

Assembly Instructions

Step 24

Fit the left side

Push the left side **1** onto the assembly.

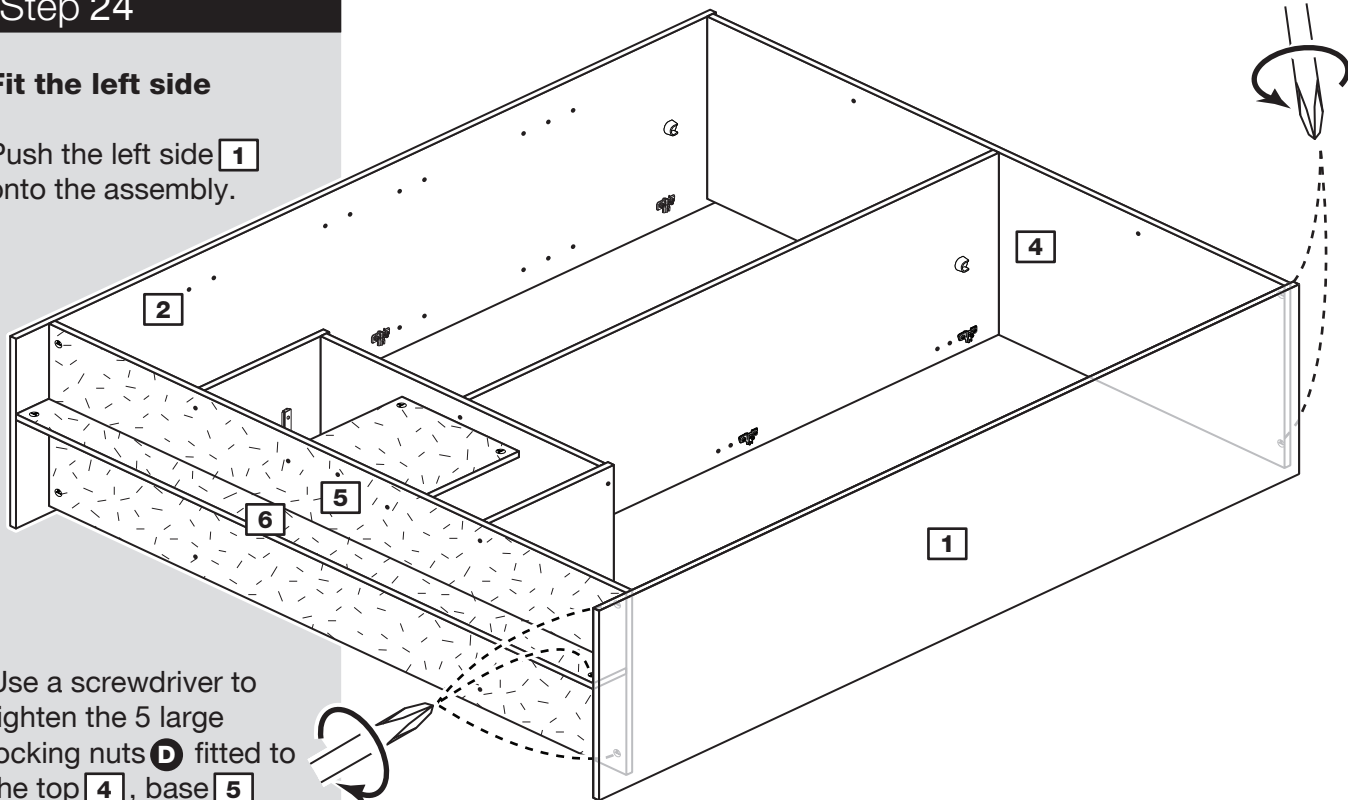

Step 25

Fit the 5 plastic nails

Tap 2 plastic nails **V** into the bottom edge of each of the sides **1** and **2** and 1 into the plinth **6**.

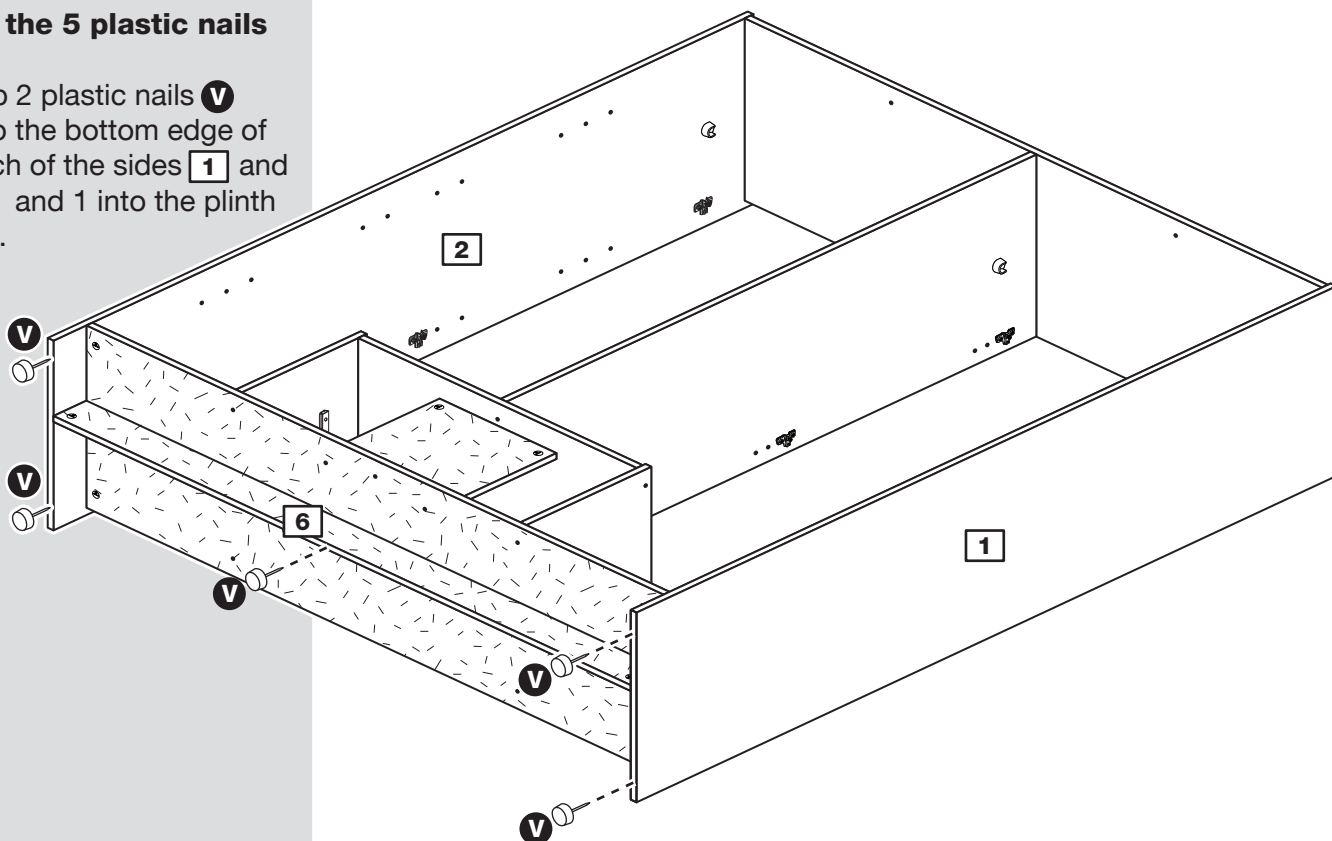

Assembly Instructions

Step 26

Fit the back panels

a: Square up the unit by making sure that measurement **x to x** equals **y to y**.

b: Place the 2 backs **17** coloured surface facing down, onto the unit as shown.

Make sure that the 2 backs **17** are pushed up tight against each other and that they meet in the centre of the centre divider's **3** back edge.

Nail **c** around the outside edges of the 2 backs **17**.

Note: Do not nail where the 2 backs meet. Nails should be spaced out evenly.

c: Push the 6 nail screws **w** through the 6 back holders **x** and tap them down between the 2 backs **17** and into the back edge of the centre divider **3**.

Keep tapping the nail screws **w** in until the back holders **x** dig into the small and large back.

a: The measurement from top corner X to bottom corner X must be equal to the measurement from top corner Y to bottom corner Y

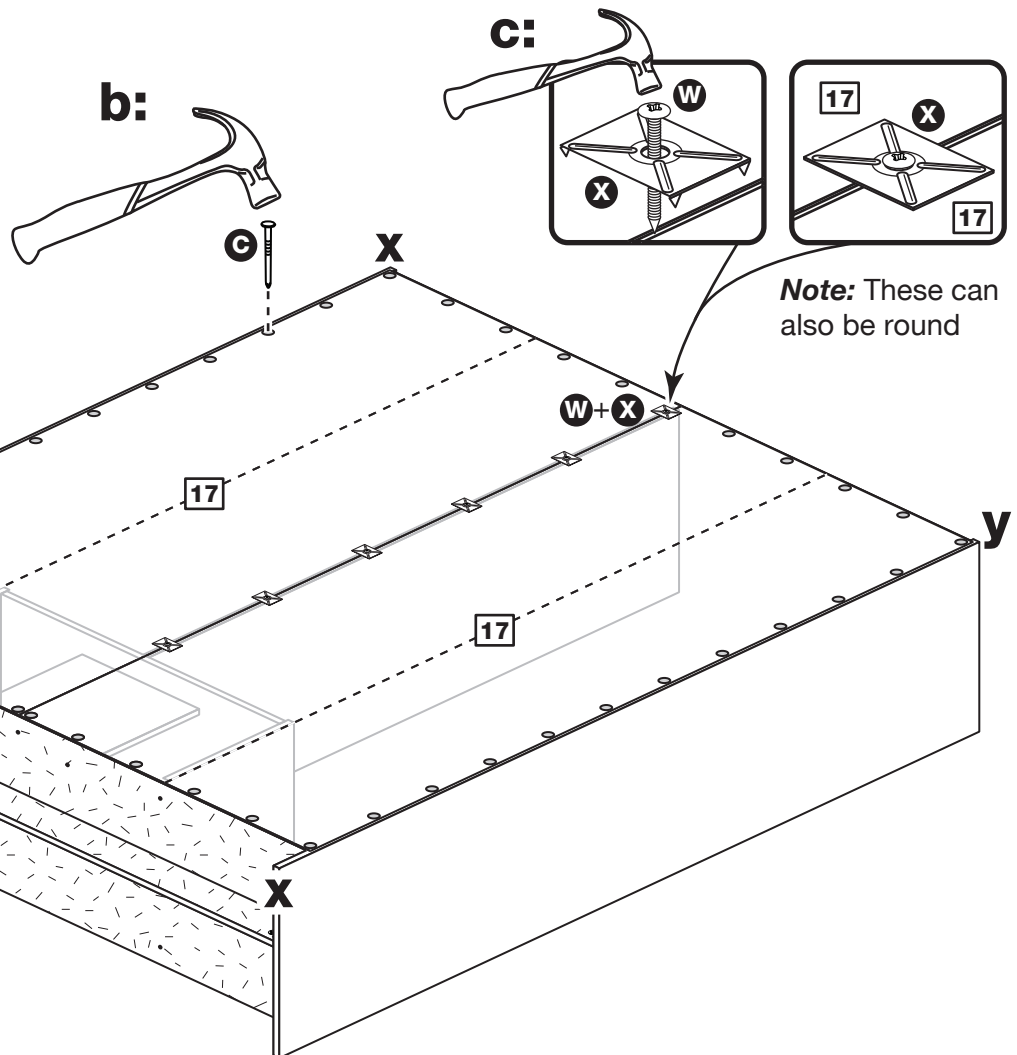

Stand the unit up for the next step.



Warning: The unit is heavy. Lift with care.

Assembly Instructions

Step 27

Fit the hanging rails and drawers

Push the hanging rails **16** into the rail holders **N** fitted to the left side **1**, right side **2** and centre divider **3**.

Starting with the bottom drawer, slide both the runners **P** forward and locate the drawer sides **12** and **13** between them, lining up the holes in the drawer wrap with the 2nd 'threaded' holes in the runners **P**.

Working from the inside of the drawer, insert 2 screws **K** through the wrap and out into the 2nd threaded hole in the runner.

Note: Do not over-tighten the screws **K. If they catch on the runner you may need to loosen them slightly.**

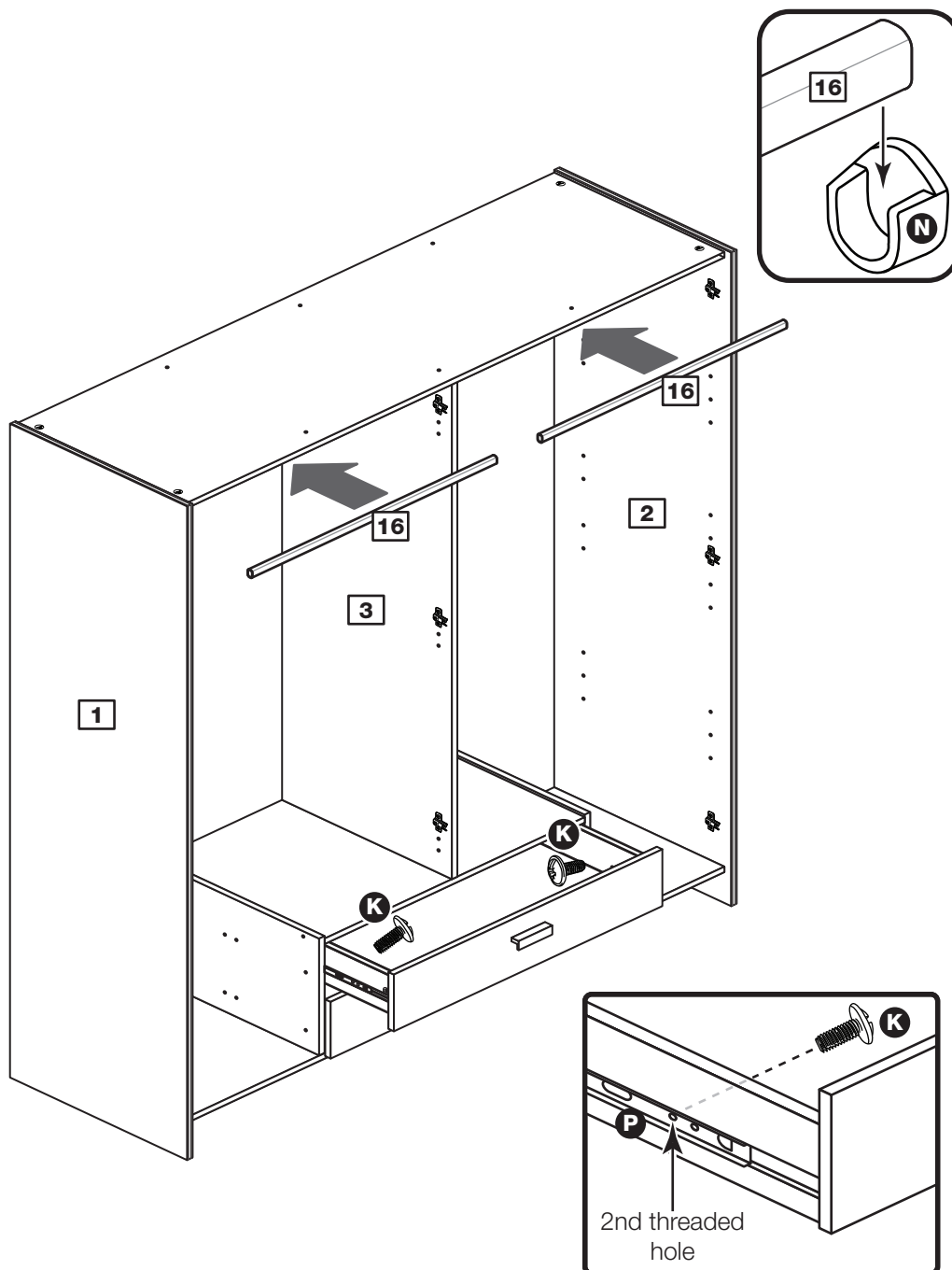

Assembly Instructions

Step 28

Prepare the large doors

Important: The 6 hinges used in this step are in the bag marked as **AHP1546**.

Push fit 3 hinges **T** into each large door **11**.

Secure each hinge with 2 screws **J**.

Note: Before securing with the screws, make sure that the hinges are positioned at 90 degrees with the edge of the door.

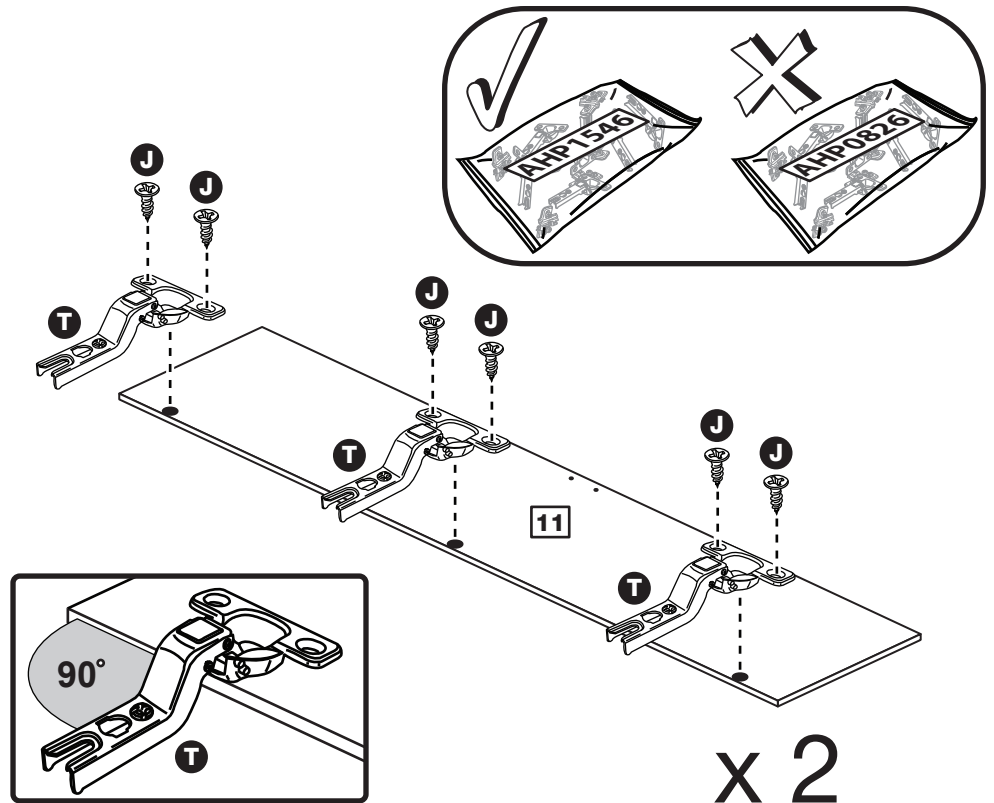

Step 29

Prepare the mirror doors

Important: The 3 hinges used in this step are in the bag marked as **AHP0826**.

Push fit 3 hinges **R** into each mirror door **10**.

Secure each hinge with 2 screws **J**.

Note: Before securing with the screws, make sure that the hinges are positioned at 90 degrees with the edge of the door.

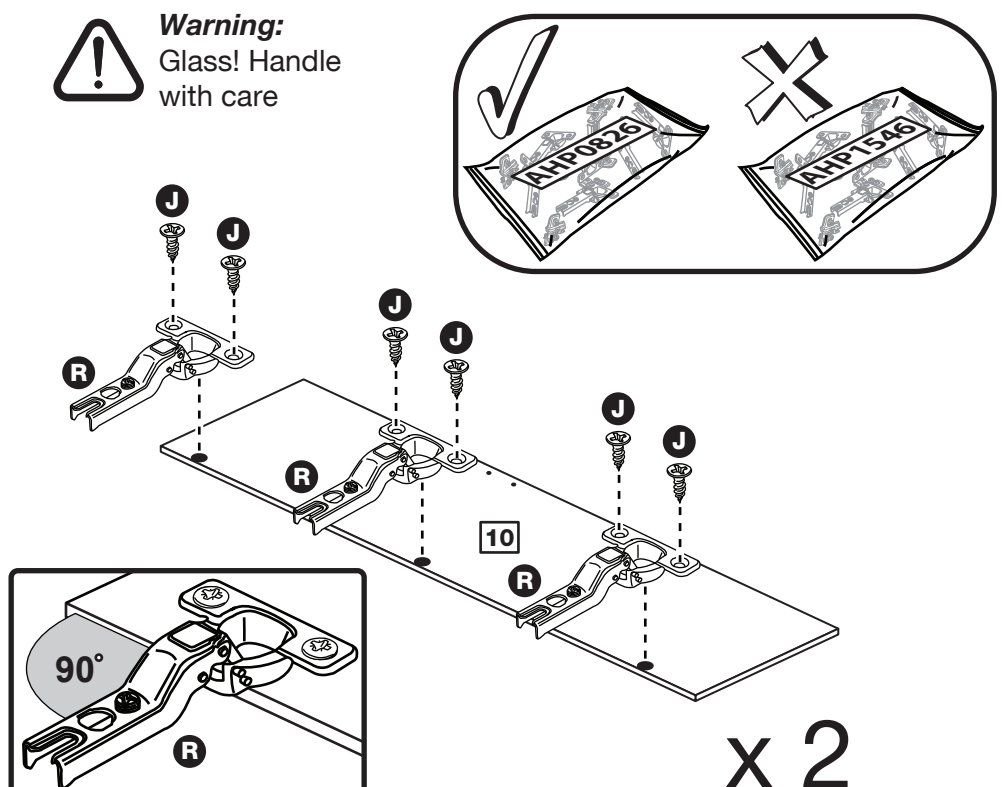

Assembly Instructions

Step 30

Drill the handle holes in each mirror door

Important: Please follow these instructions carefully.

Lay the 2 mirror doors **10** down onto a smooth surface.

Check that the hinges and holes are in the same place as the diagrams.

Note: We recommend the use of a small piece of waste wood, placed behind the hole while drilling, to reduce the possibility of any breakout.

Using the pilot hole in the rear face of the door, drill through the hole indicated opposite, using a 2.5mm diameter drill.

Turn the door over and open out the 2.5mm hole that you have just drilled by drilling back through it with a 5mm drill.

IMPORTANT

Carefully choose the 2 holes you need to drill for each mirror door.
Only drill 1 set of handle holes in each mirror door.



Warning:
Glass! Handle with care

ONLY drill these 2 holes in the mirror door

This will be the LEFT mirror door

DO NOT drill these holes

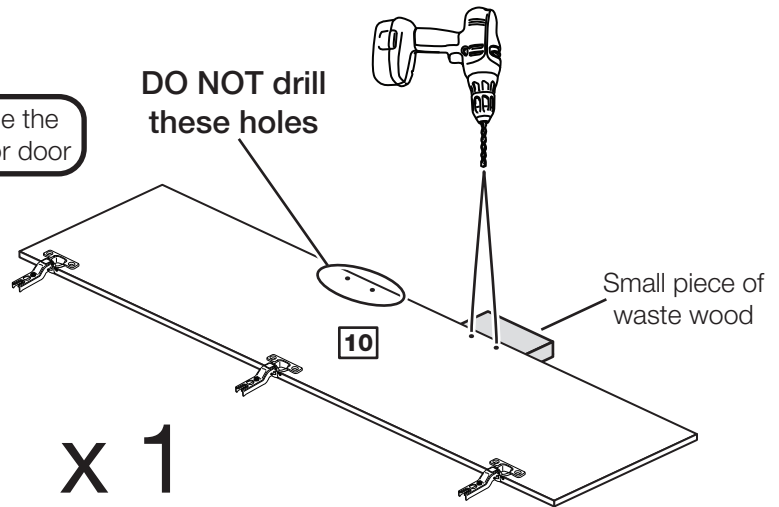

Warning:
Glass! Handle with care

ONLY drill these 2 holes in the mirror door

This will be the RIGHT mirror door

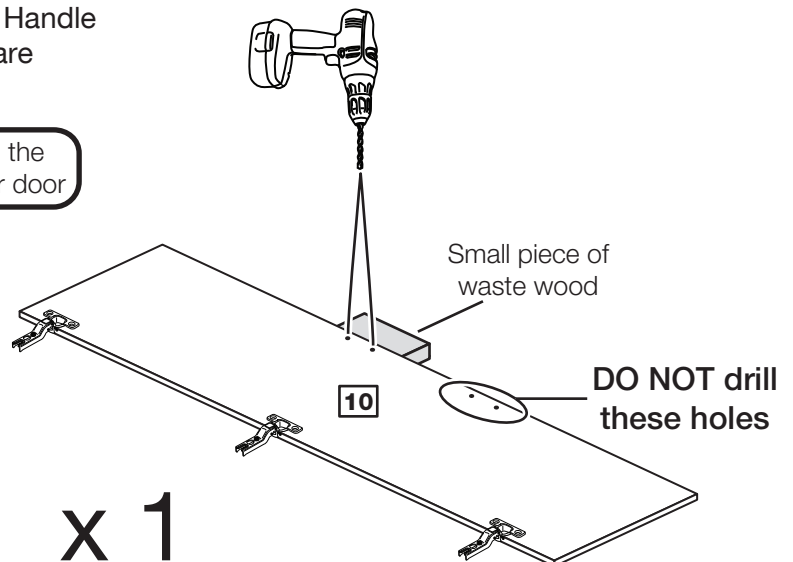

Assembly Instructions

Step 31

Fit the mirror doors and handles

Note: The easiest way to attach the mirror doors **10** is to fit the top hinge first, then align and fit the other hinges.

a: Push the hinge **R** onto the front part of the hinge plate **Q**. The recess at the bottom of screw B goes into the slot in the hinge plate.

b: Keep the hinge **R** FLAT against the hinge plate **Q** as you slide it across as far as it will go. Tighten screw A.

c: The hinge **R** must be flat against the hinge plate **Q** prior to any adjustment.

d: The hinge **R** must NOT be AT AN ANGLE to the hinge plate **Q** when assembled. This would indicate that the recess at the bottom of screw B had not located in the slot in the hinge plate and the hinge would not be secure. Remove the hinge from the hinge plate and then re-assemble being careful to follow instructions a-c.

e: Attach a handle **M** to each mirror door **10** using 2 screws **H**.

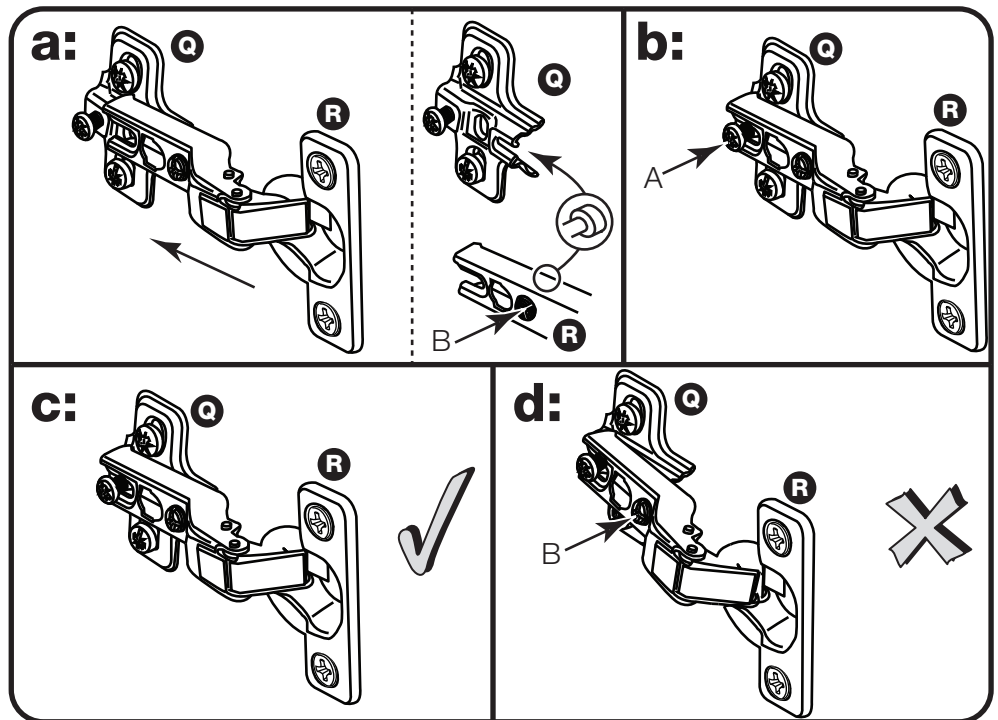

Warning:
Glass! Handle with care

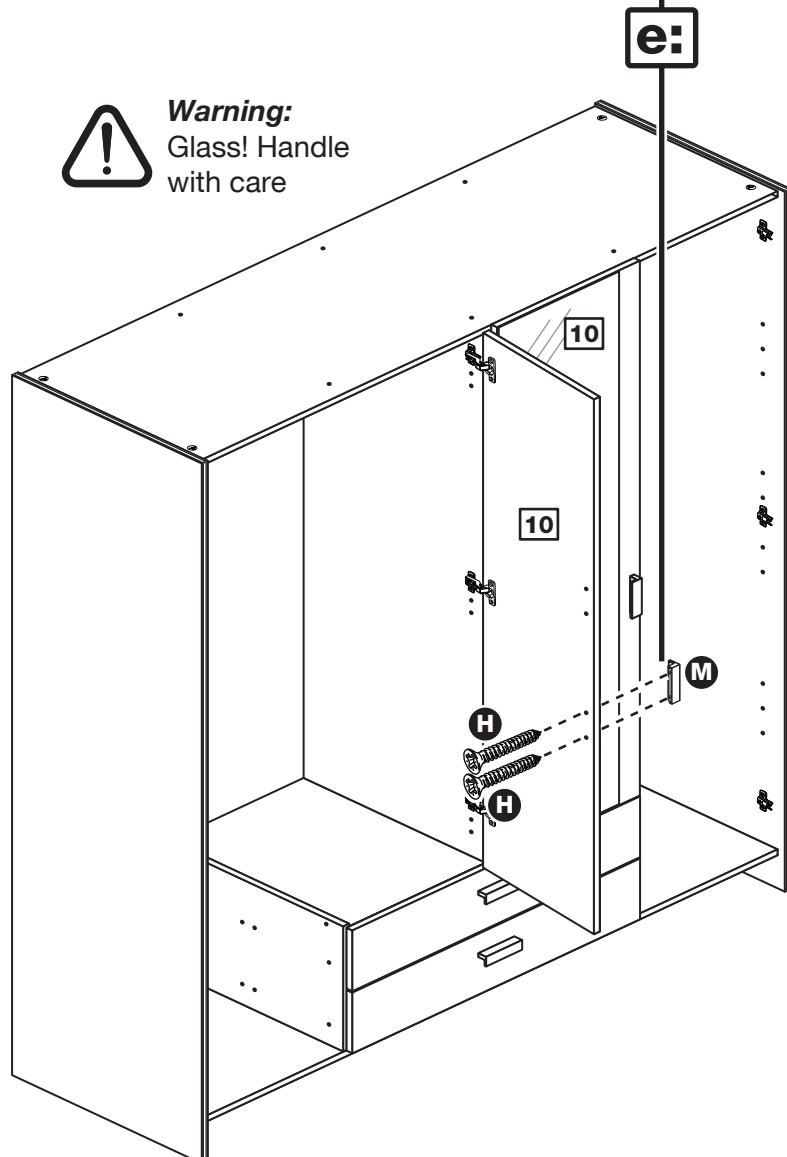

Assembly Instructions

Step 32

Fit the large doors and handles

Note: The easiest way to attach each door **11** is to fit the top hinge first, then align and fit the other hinges.

a: Push the hinge **T** onto the front part of the hinge plate **S**.
The recess at the bottom of screw B goes into the slot in the hinge plate.

b: Keep the hinge **T** FLAT against the hinge plate **S** as you slide it across as far as it will go. Tighten screw A.

c: The hinge **T** must be flat against the hinge plate **S** prior to any adjustment.

d: The hinge **T** must NOT be AT AN ANGLE to the hinge plate **S** when assembled. This would indicate that the recess at the bottom of screw B had not located in the slot in the hinge plate and the hinge would not be secure. Remove the hinge from the hinge plate and then re-assemble being careful to follow instructions a-c.

e: Attach a handle **M** to each large door **11** using 2 screws **H**.

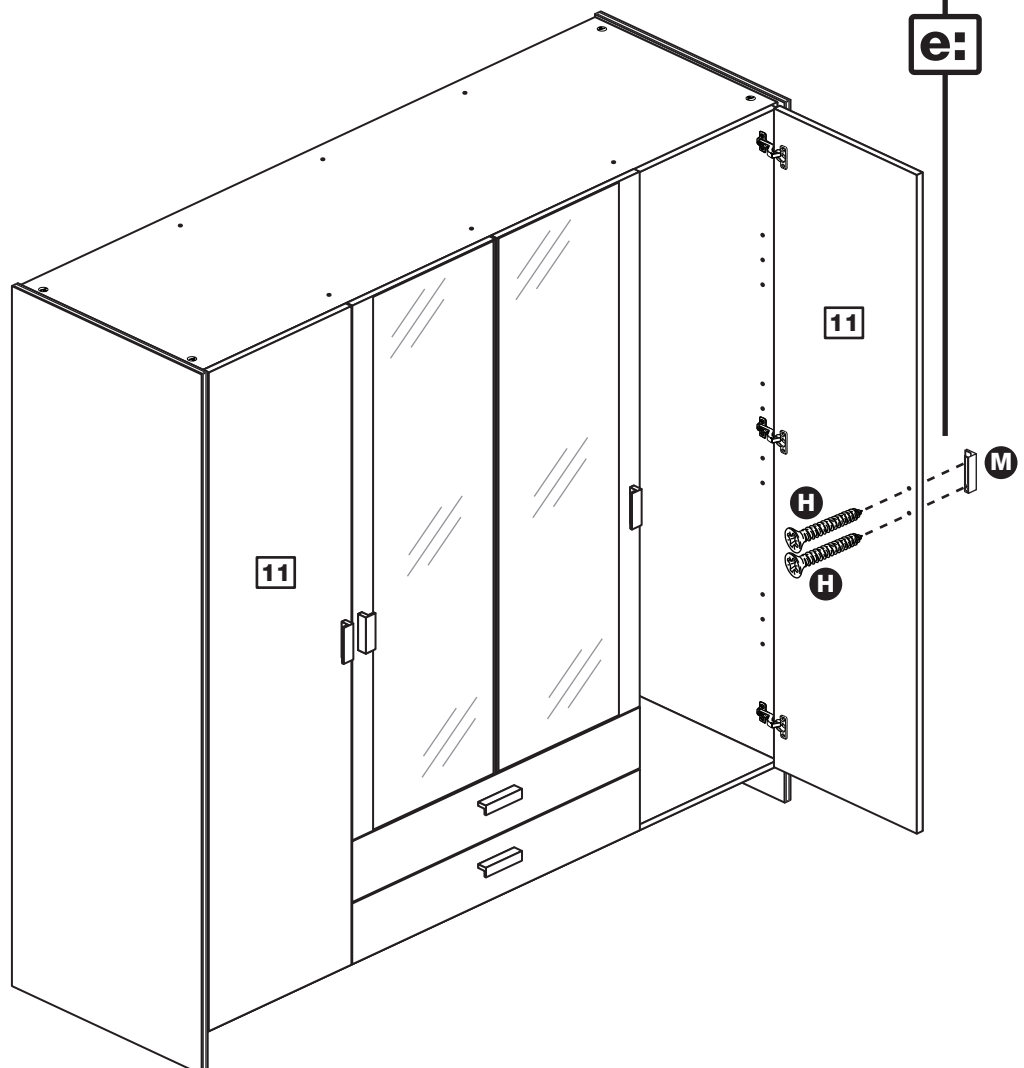
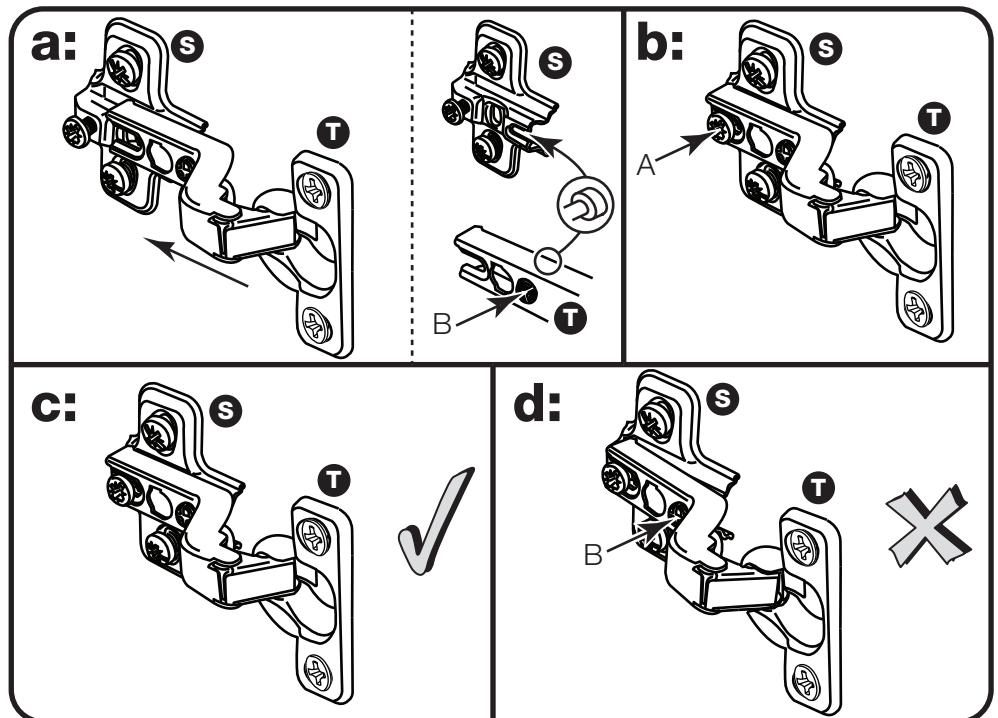

Assembly Instructions

Step 33

Adjust the doors if needed

a: Before adjusting the doors, use a spirit level to check the base (or top) of the unit is level, front-to-back and side-to-side in the 3 positions shown. Use suitable packing pieces (not supplied) to make the unit level BEFORE making any adjustment to the hinges, as shown.

b: Height adjustment.

Loosen screws A on hinge plates and move door up or down as required. Retighten screw A.

c: Forward and Back adjustment.

Loosen screw B on hinge plate and move door in or out as required. Retighten screw B.

d: Sideways adjustment.

To move door 'out' loosen screw C. To move door 'in' tighten screw C.

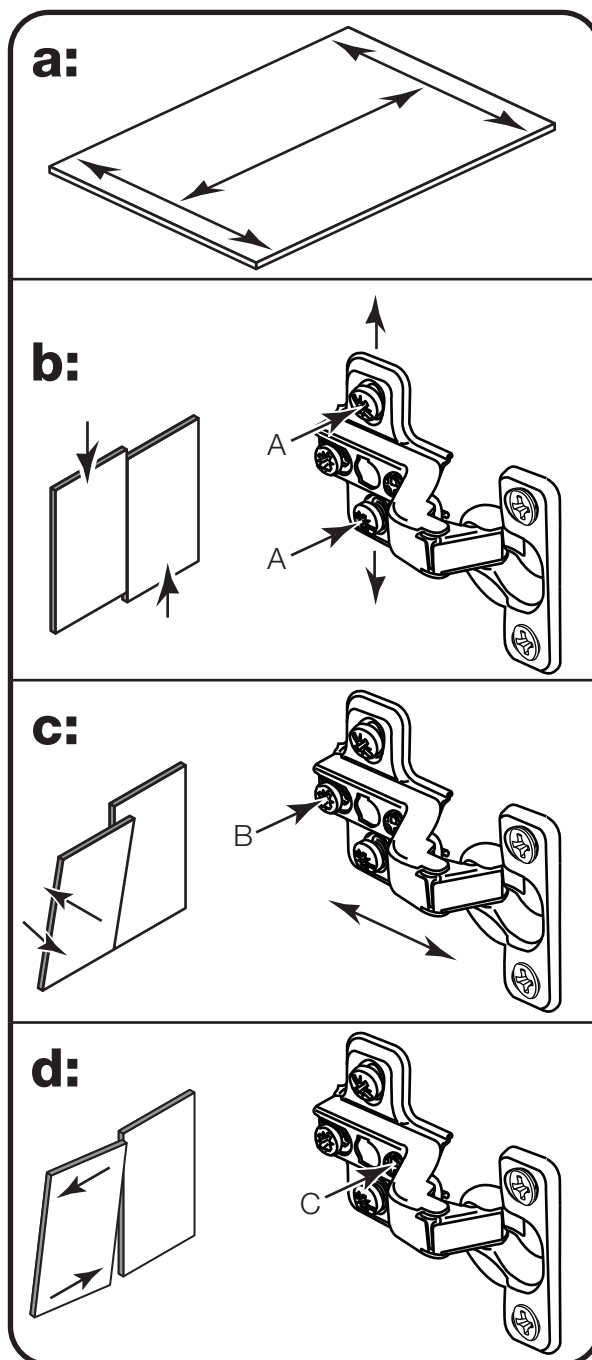

This shows the hinge and plate that is fitted to the outer doors. The ones fitted to the centre doors are adjusted in the same way.



Assembly Instructions

Step 34



Fit the bracket

To prevent possible overbalancing, we recommend that this unit is secured to a suitable wall by use of the bracket  fitted to the top of the unit.

Fixings are not supplied, as they will need to suit the wall type and the length of screw will depend on the distance from the back of the unit to the wall.

Fix the bracket  loosely onto the top of the unit using screw  and mark the wall for the wall fixing.

Swivel the bracket  away from the wall and drill a hole in the wall using a suitable drill bit and fit your wall fixing.

Swivel the bracket  back and fix the bracket to the wall, then tighten Screw .

Note: Take care when drilling the wall that you do not drill into any pipes, wires etc. If in doubt, consult an expert.



Warning: The unit is heavy. Lift with care.

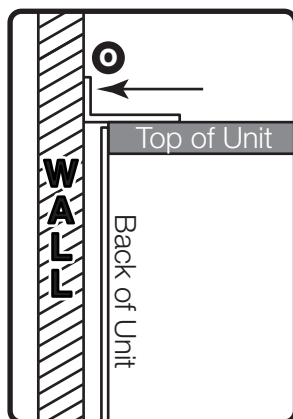
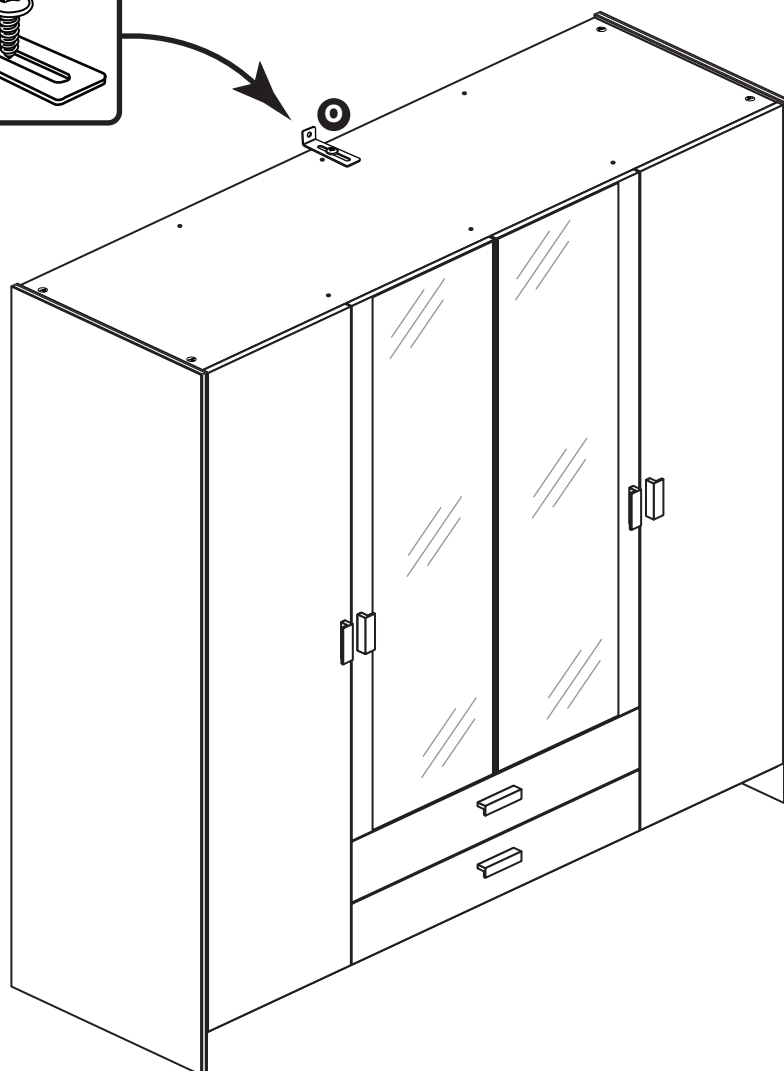
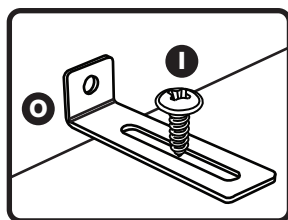

Assembly Instructions

Step 35

Assembly is complete

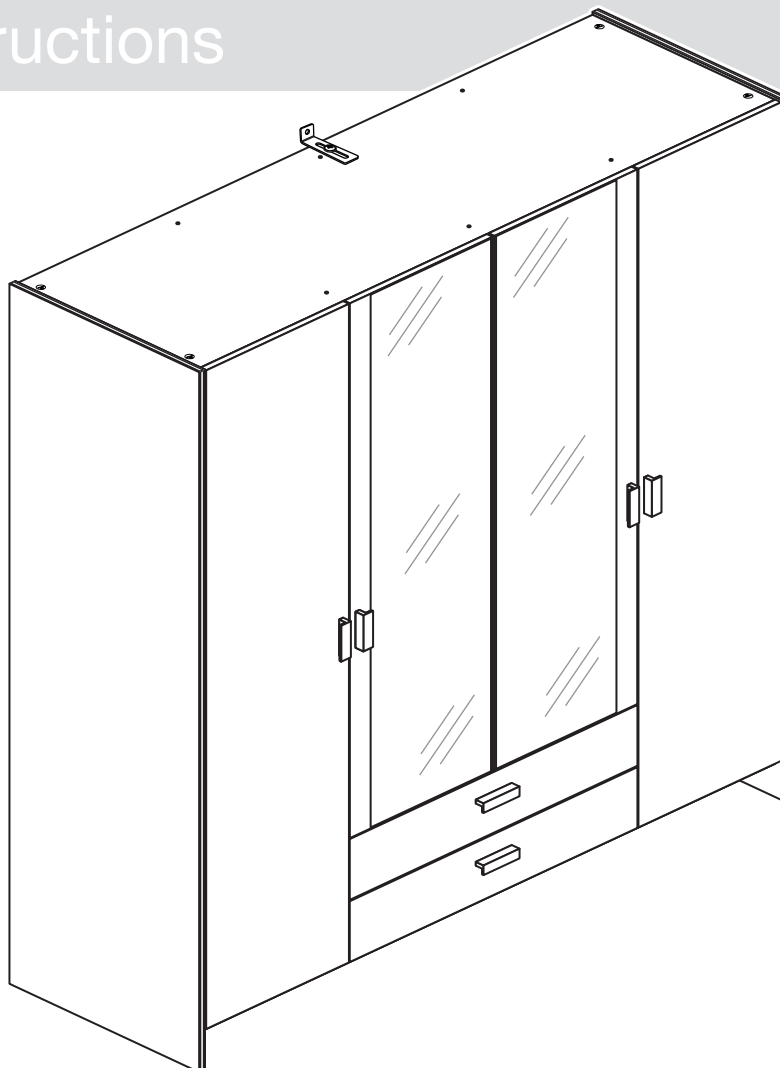

IMPORTANT INFORMATION ABOUT THIS PRODUCT

This product complies with the requirements of BS 7449:1991 and has been manufactured by DECORATIVE PANELS FURNITURE LTD, TEESIDE INDUSTRIAL ESTATE, THORNABY-ON-TEES, CLEVELAND, TS17 9LT.

The product code for this unit and the item code(s) for the glass components are listed in the Assembly Instructions along with a description of the type of glass used. All clear/tinted glass complies with the requirements of BS 6206 Class A. All mirrors comply with the requirements of BS 6206 Class C. If the glass component contained in this unit is chipped or broken consult the furniture manufacturer, retailer, or agent with regard to obtaining a manufacturing specification and shape for replacement glass quoting the unit description and batch number or date of manufacture.

Do not place very hot or very cold items against or in close proximity to glass surface(s) unless adequately thick insulating material is used to prevent such items coming in contact with the glass.

Do not strike the glass with hard or pointed items.

Do not sit or stand upon horizontal glass surfaces.

When cleaning glass panels use a damp cloth or leather with washing liquid or soft soap if necessary - do not use washing powders or any other substance containing abrasives since these substances scratch glass.

If stated in the instruction leaflet, it is essential that this unit is fixed to a wall.

KEEP THESE INSTRUCTIONS FOR FUTURE USE

If you need help or have damaged or missing parts, call the **Customer Helpline: 08456 400800** and quote the reference numbers on the component pages.

Argos Ltd, 489-499 Avebury Boulevard, Central Milton Keynes, MK9 2NW