

Stirling - 1 Drawer 2 Door Robe

Assembly Instructions - Please keep for future reference

343/9049

345/7162

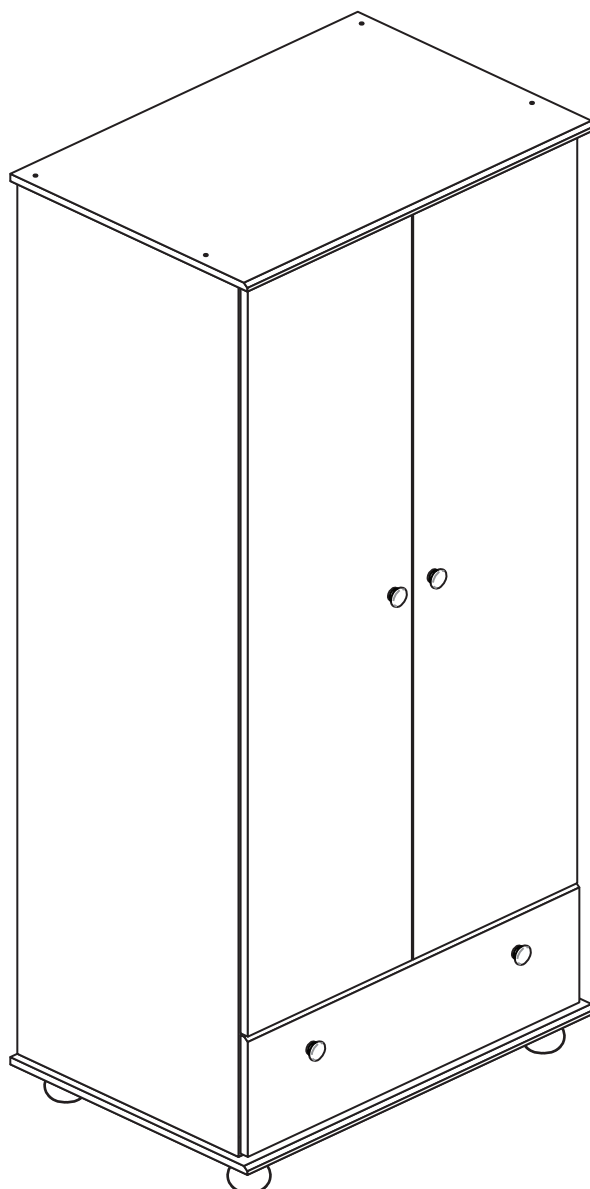

Dimensions

Width - 72cm

Depth - 49cm

Height - 189cm



**MADE IN
BRITAIN**

Important - Please read these instructions fully before starting assembly

If you need help or have damaged or missing parts, call the **Customer Helpline: 08456 400800**



Safety and Care Advice

Important - Please read these instructions fully before starting assembly

- **Warning:** This unit weighs approximately 48kgs. Please lift with care.
- Check you have all the components and tools listed on pages 1, 2 and 3.
- Remove all fittings from the plastic bags and separate them into their groups.
- Keep children and animals away from the work area, small parts could choke if swallowed.
- Parts of the assembly will be easier with 2 people.

- Make sure you have enough space to layout the parts before starting.
- Do not stand or put weight on the product, this could cause damage.
- Assemble the item as close to its final position (in the same room) as possible.
- Assemble on a soft level surface to avoid damaging the unit or your floor (use opened out unit carton).



- We do not recommend the use of power drill/drivers **for inserting screws**, as this could damage the unit. Only use hand screwdrivers.









- **Safety note:** It is recommended that this unit is secured to a wall using the bracket supplied.

- Dispose of all packaging carefully and responsibly.

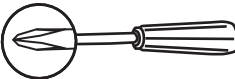
Care and maintenance

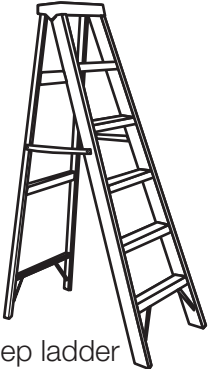
- Only clean using a damp cloth and mild detergent, do not use bleach or abrasive cleaners.
- From time to time check that there are no loose screws on this unit.
- This product should not be discarded with household waste. Take to your local authority waste disposal centre.

Tools required

 Rule	 Spirit level	 Eye protection (when using a hammer or drill)	 Cross-head screwdriver	 Electric drill (do not use for fitting screws)	 Step ladder
 Square	 Scissors	 Hammer	 Bradawl		

Note: If required the next page can be cut out and used as reference throughout the assembly. Keep this page with these instructions for future reference.

Components - Panels

If you have damaged or missing components, call the **Customer Helpline: 08456 400800** quoting the reference numbers below

Please check you have all the panels listed below

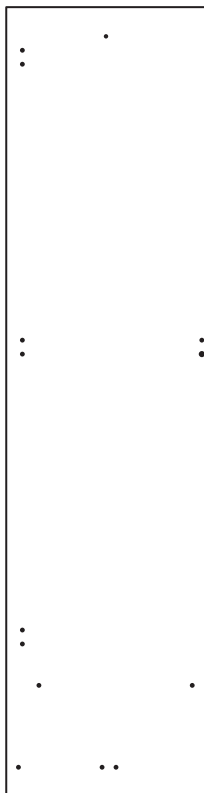

1 Left Side (D3016A)
(1810 x 457mm)

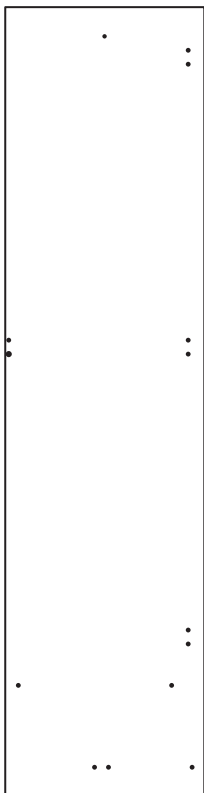

2 Right Side (D3017A)
(1810 x 457mm)



3 Top (D3014A)
(718 x 490mm)



4 Base (D3015B)
(718 x 490mm)



5 Horizontal (D3018A)
(659 x 456mm)

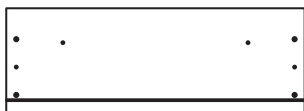

6 Drawer Front (D3000A)
(685 x 245mm)

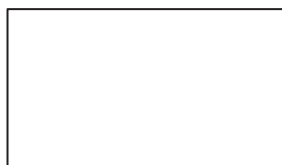

7 Drawer Base (T637-367)
(637 x 367mm)

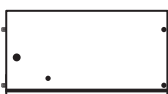

8 Left Drawer Side (W370-195LH)
(370 x 195mm)

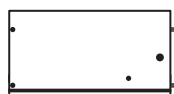

9 Right Drawer Side (W370-195RH)
(370 x 195mm)



10 Drawer Back (W626-195)
(626 x 195mm)



11 Hanging Rail (FHR649)
(649mm long)



12 Back Rail (D3020A)
(659 x 123mm)

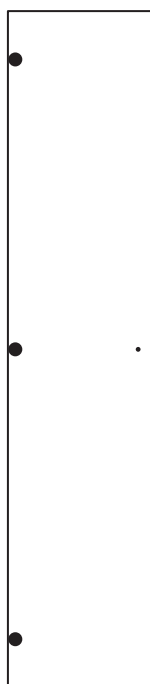

13 Door (D3019A)
(1553 x 339mm) x 2

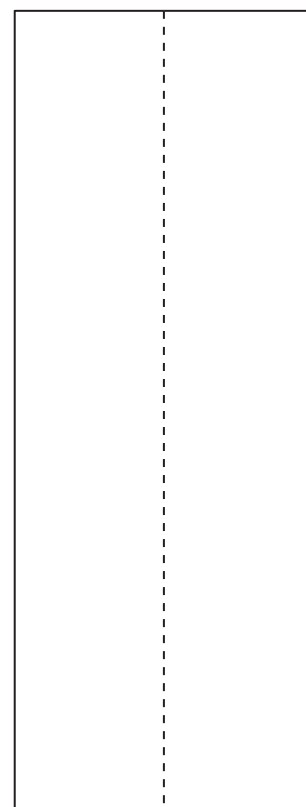

14 Back (X1836-685)
(1836 x 685mm)











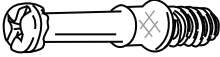



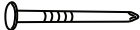



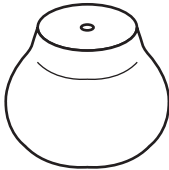

Components - Fittings

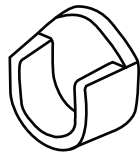
If you have damaged or missing components, call the **Customer Helpline: 08456 400800** quoting the reference numbers below

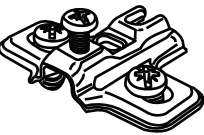
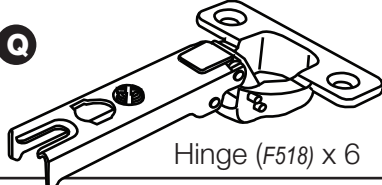
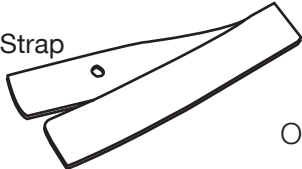
Please check you have all the fittings listed below

Note: The quantities below are the correct amount to complete the assembly. In some cases more fittings may be supplied than are required.

<p>A </p> <p>Metal dowel (F901) x 4</p>	<p>B </p> <p>Large locking nut (F900) x 2</p>	<p>C </p> <p>Small locking nut (F3) x 2</p>
<p>D </p> <p>Wooden dowel (F22) x 2</p>	<p>E </p> <p>Nail (F51) x 33</p>	<p>F </p> <p>Knock-in Peg (F171GY) x 4</p>
<p>G </p> <p>40mm Screw (F910) x 16</p>	<p>H </p> <p>38mm Screw (F81) x 4</p>	<p>I </p> <p>9mm Screw (F73) x 4</p>
<p>J </p> <p>9mm Screw (F74) x 2</p>	<p>K </p> <p>Foot (F340) x 4</p>	<p>L </p> <p>13mm Screw (F63) x 14</p>
<p>M </p> <p>Wedgefix (F639) x 4</p>	<p>N </p> <p>Rail holder (F1014) x 2</p>	<p>O </p> <p>Handle (F463) x 4</p>
<p>P </p> <p>Hinge plate (F523) x 6</p>	<p>Q </p> <p>Hinge (F518) x 6</p>	
<p>R    </p> <p>Strap Screw Washer x 2</p> <p>Overbalance protector kit (F269) x 1</p>		
<p>S </p> <p>Drawer runner (F1004) x 2</p>		

Ruler - Use this ruler to help correctly identify the screws

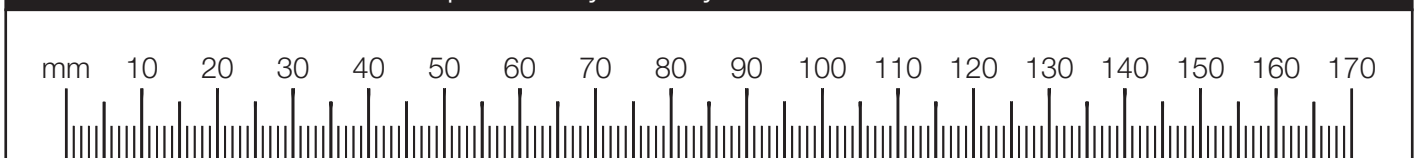

Assembly Instructions

If you have damaged or missing components, call the
Customer Helpline: 08456 400800 quoting the reference
numbers below

Step 1

Prepare the drawer front

Screw 2 metal dowels **A** into the drawer front **6**.

Note: Tighten the metal dowels up fully against the panels.

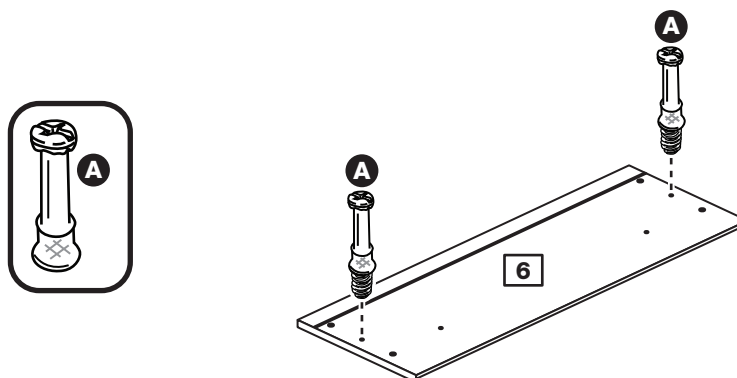

Step 2

Prepare the drawer sides

Insert a small locking nut **C** into the hole shown on the left drawer side **8** and the right drawer side **9**.

Note: The arrow on the locking nut **must** point towards the hole in the edge of the panel.

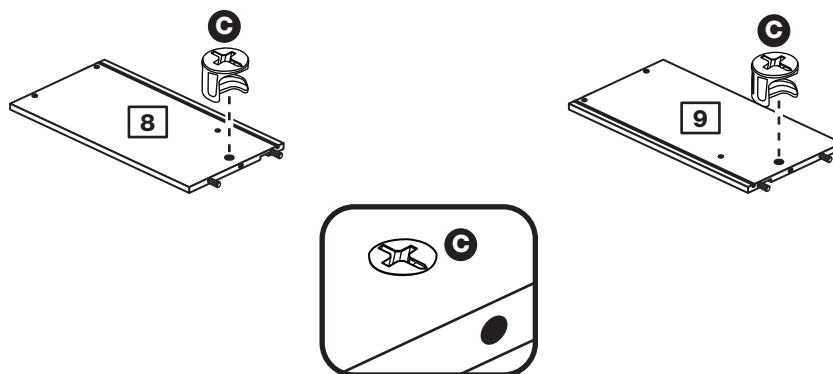

Step 3

Attach the drawer sides to the drawer front

Push the left drawer side **8** and right drawer side **9** onto the back of the drawer front **6**.

Turn the small locking nuts **C** on the left drawer side **8** and right drawer side **9**.

Note: Turn the locking nuts **C** clockwise to secure panels - more than 1/2 a turn.

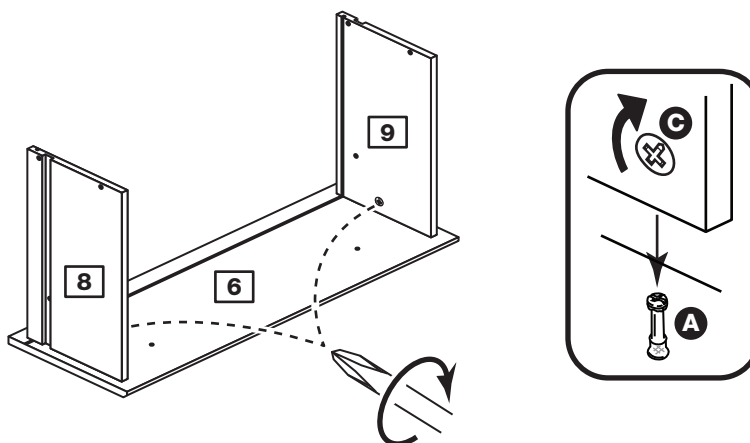

Assembly Instructions

Step 4

Fit the drawer base

Slide the drawer base **7** down the grooves in the large drawer sides **8** and **9** and down into the groove in the large drawer front **6**.

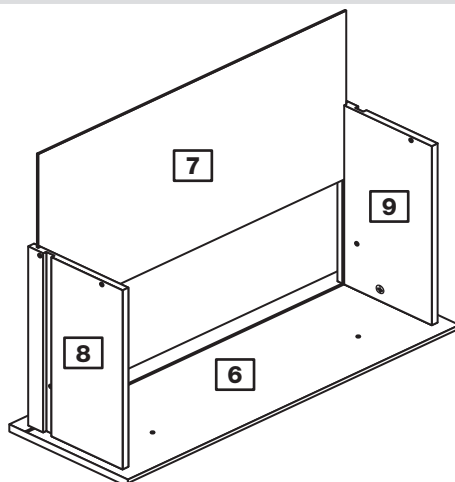

Step 5

Fit the large drawer back

Fit the drawer back **10** between the drawer sides **8** and **9**. Make sure that the drawer base **7** fits into the groove in the drawer back **10**.

Hold the drawer back **10** in position and tap the knock-in pegs **F** through the holes in the drawer sides **8** and **9**.

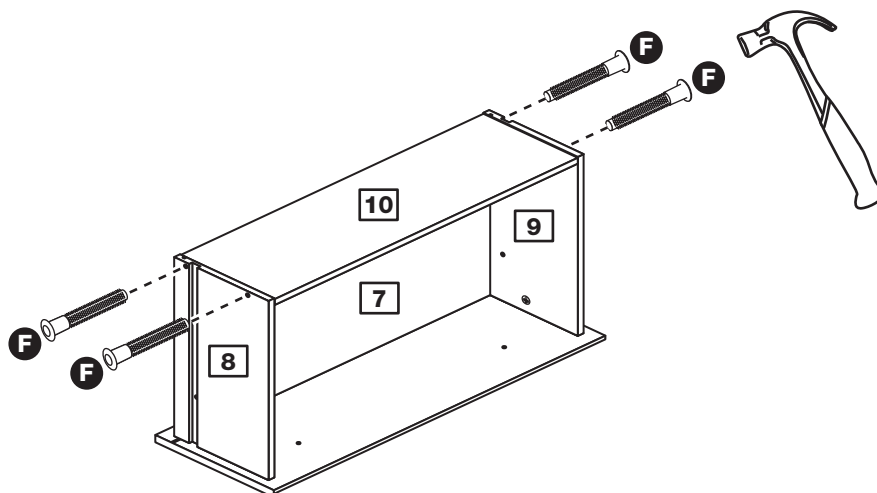

Step 6

Attach the handles

Attach 2 handles **O** to the drawer front **6** using screws **H**.

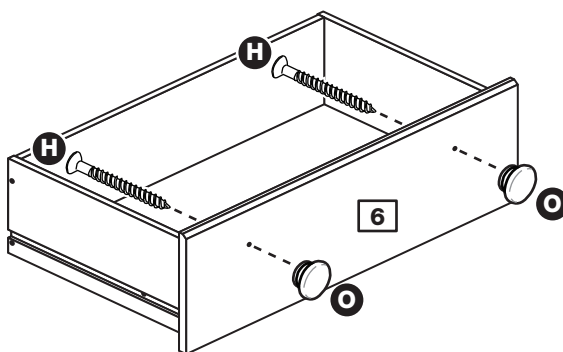

Step 7

Fit the wedgexes

Turn the large drawer assembly over and slide 4 wedgexes **M** into the front and back grooves, as shown, and tighten up the screws.

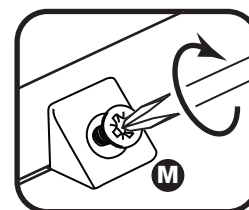
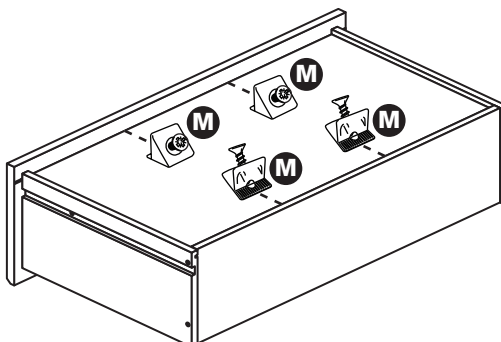

Assembly Instructions

Step 8

Prepare the left side

a: Fit 3 hinge plates **P** to the left side **1** making sure that the slot is facing towards the finished front edge.

Push a rail holder **N** into the left side **1**. Make sure that it is fitted straight, in line with the panel edges and then secure with screw **L**.

Place a runner **S** onto the left side **1**. Slide back the top of runner and use the 2nd hole from the front to fit the 1st screw **I**.

Screw a metal dowel **A** into the left side **1**.

b: Slide the runner **S** back the other way and fit the 2nd screw **I** into the corresponding hole in the left side **1**.

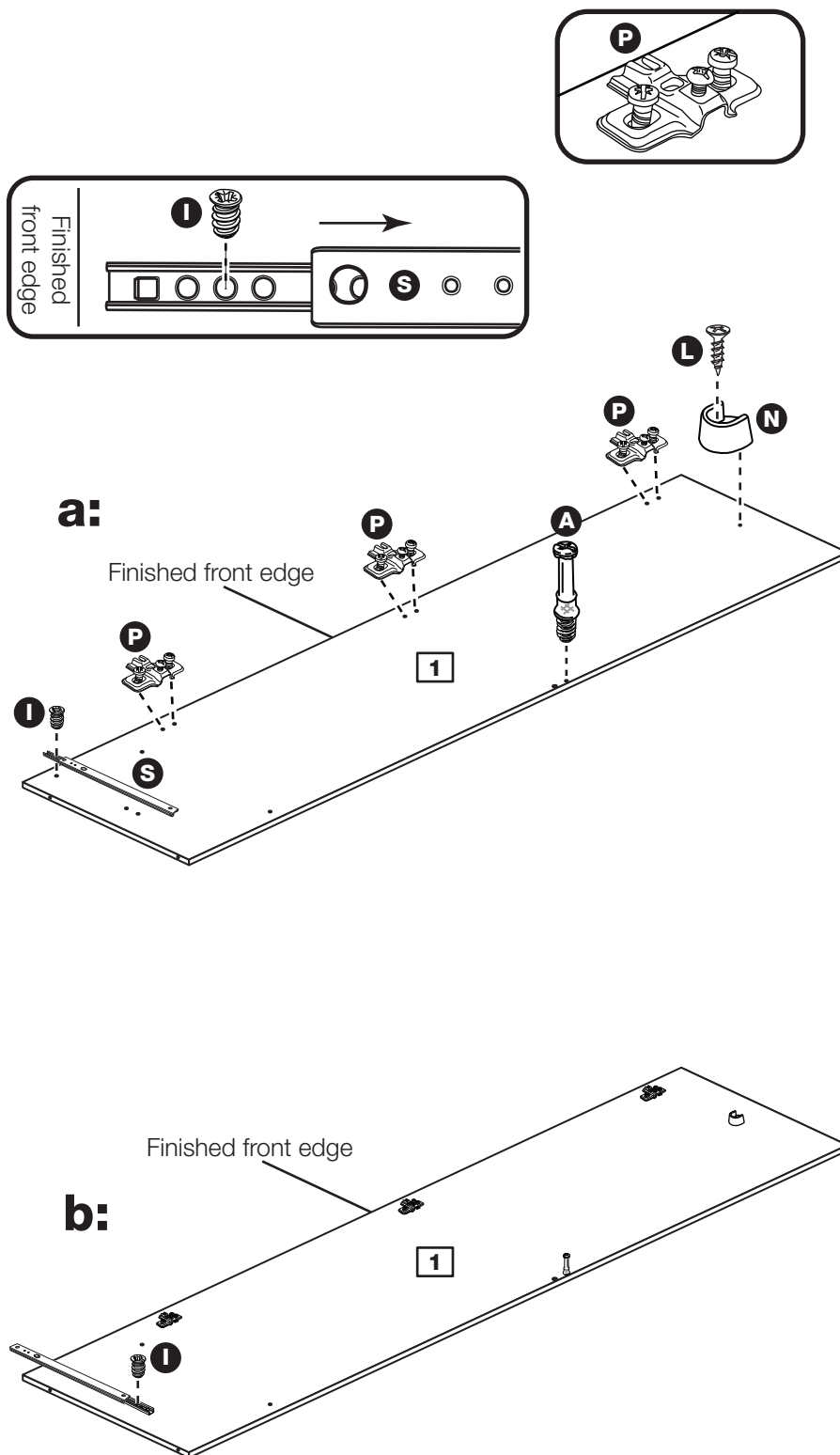

Assembly Instructions

Step 9

Prepare the right side

a: Fit 3 hinge plates **P** to the right side **2** making sure that the slot is facing towards the finished front edge.

Push a rail holder **N** into the right side **2**. Make sure that it is fitted straight, in line with the panel edges and then secure with screw **L**.

Place a runner **S** onto the right side **2**. Slide back the top of runner and use the 2nd hole from the front to fit the 1st screw **I**.

Screw a metal dowel **A** into the right side **2**.

b: Slide the runner **S** back the other way and fit the 2nd screw **I** into the corresponding hole in the right side **2**.

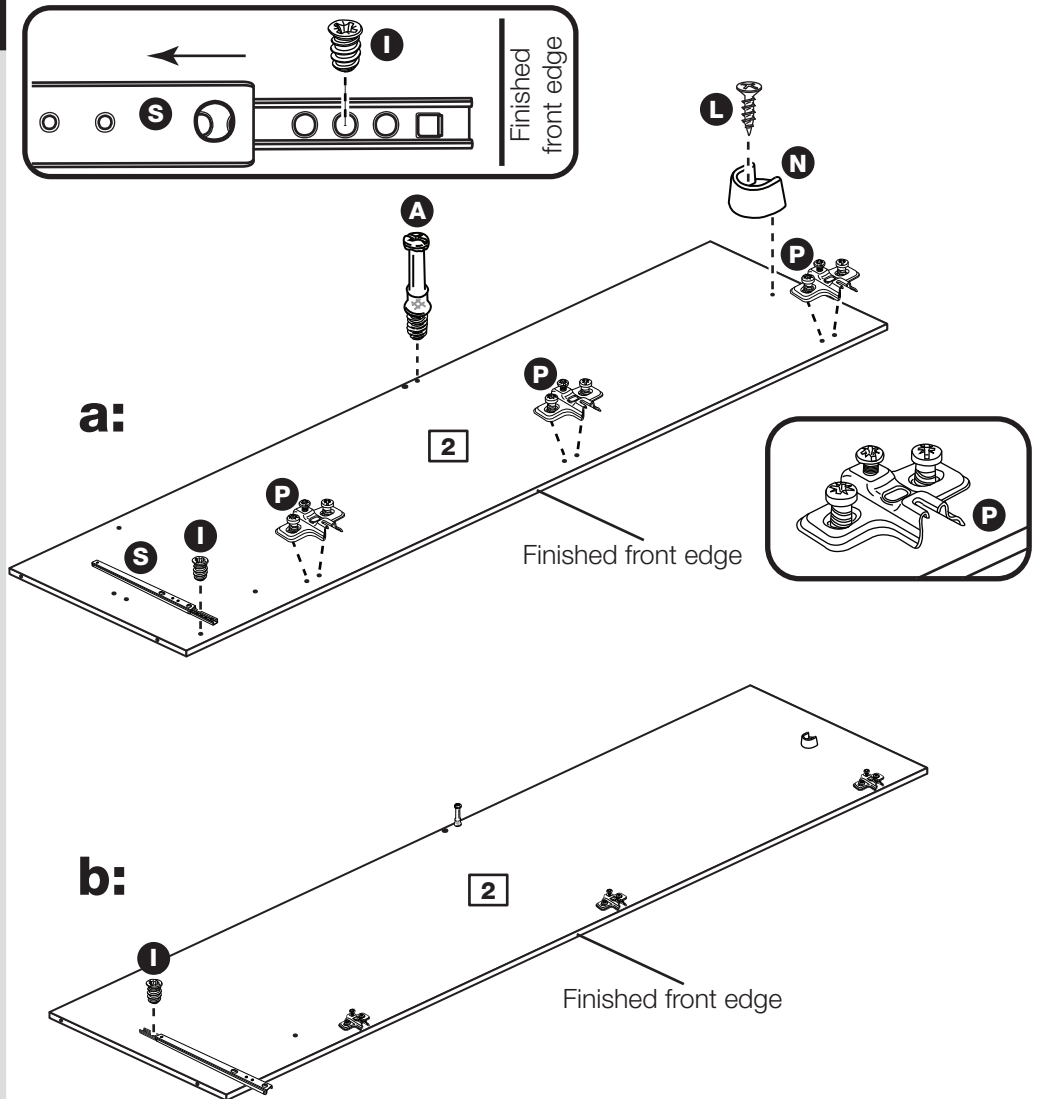

Step 10

Fit the horizontal to the right side

Attach the horizontal **5** to the right side **2** using 2 screws **G**.

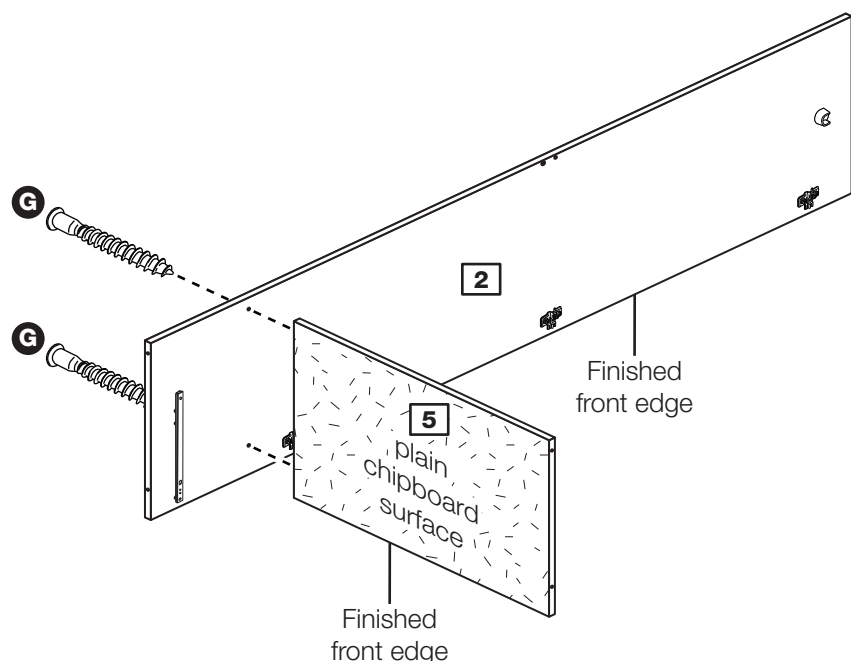

Assembly Instructions

Step 11

Prepare the back rail

Insert 2 large locking nuts **B** into the back rail **12**.

Note: The arrow on the locking nut **must** point towards the hole in the edge of the panel.

Tap 2 wooden dowels **D** into the back rail **12**.

Note: Wooden dowels **must not** stick out from the edge by more than 10mm or they may damage other panels.

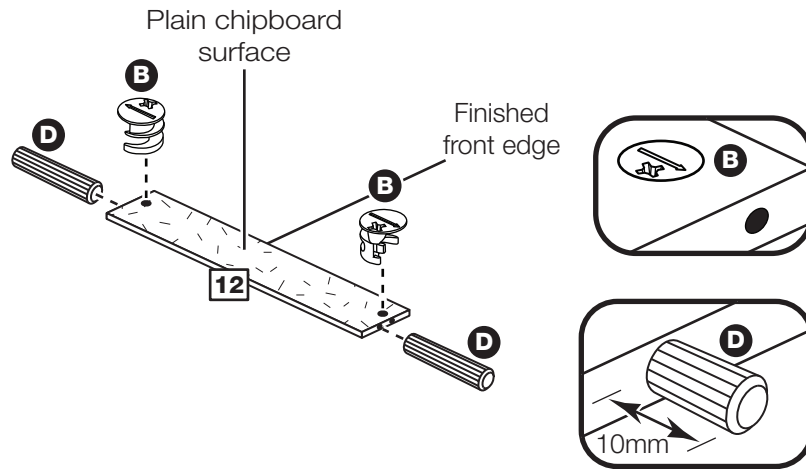

Step 12

Fit the back rail to the right side

Push the back rail **12** onto the right side **2**.

Use a screwdriver to tighten the large locking nut **B** fitted to the back rail **12**.

Note: Turn the large locking nut **B** as far as it will go - more than 1/2 a turn.

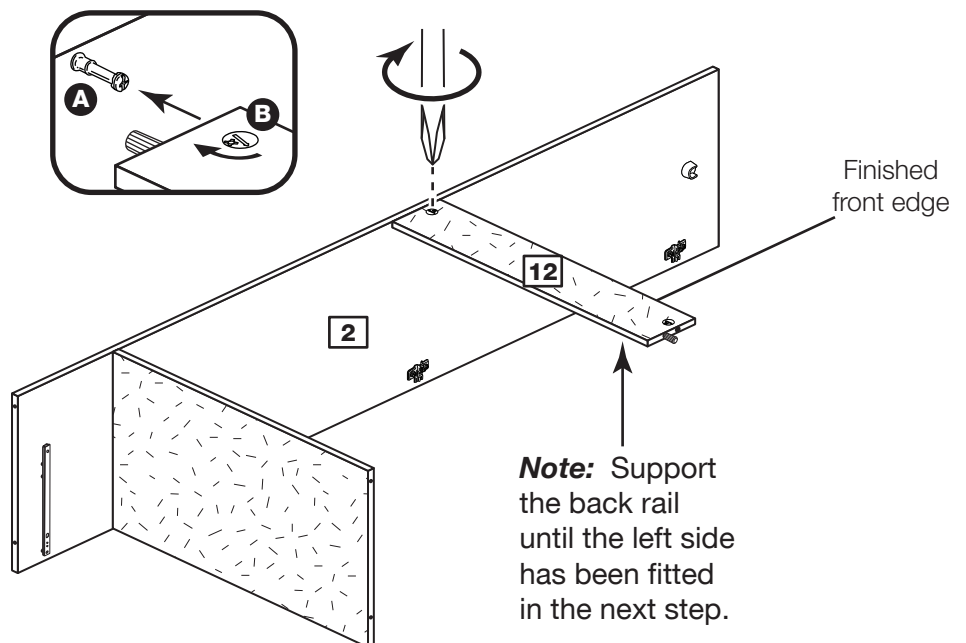

Assembly Instructions

Step 13

Fit the left side

Push the left side **1** onto the horizontal **5** and back rail **12**.

Attach the left side **1** to the horizontal **5** using 2 screws **G**.

Use a screwdriver to tighten the large locking nut **B** fitted to the back rail **12**.

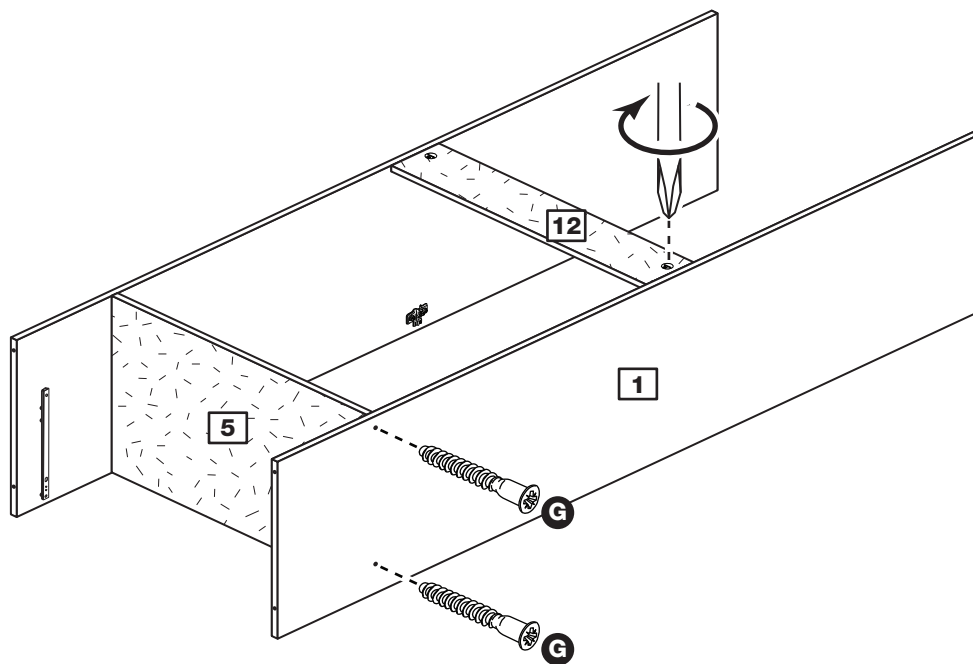

Step 14

Fit the top

Attach the top **3** to the left side **1** and right side **2** using 4 screws **G**.

Note: To make it easier to fit the top and base panels, place polystyrene blocks from the packaging underneath the side panels to raise the assembly.

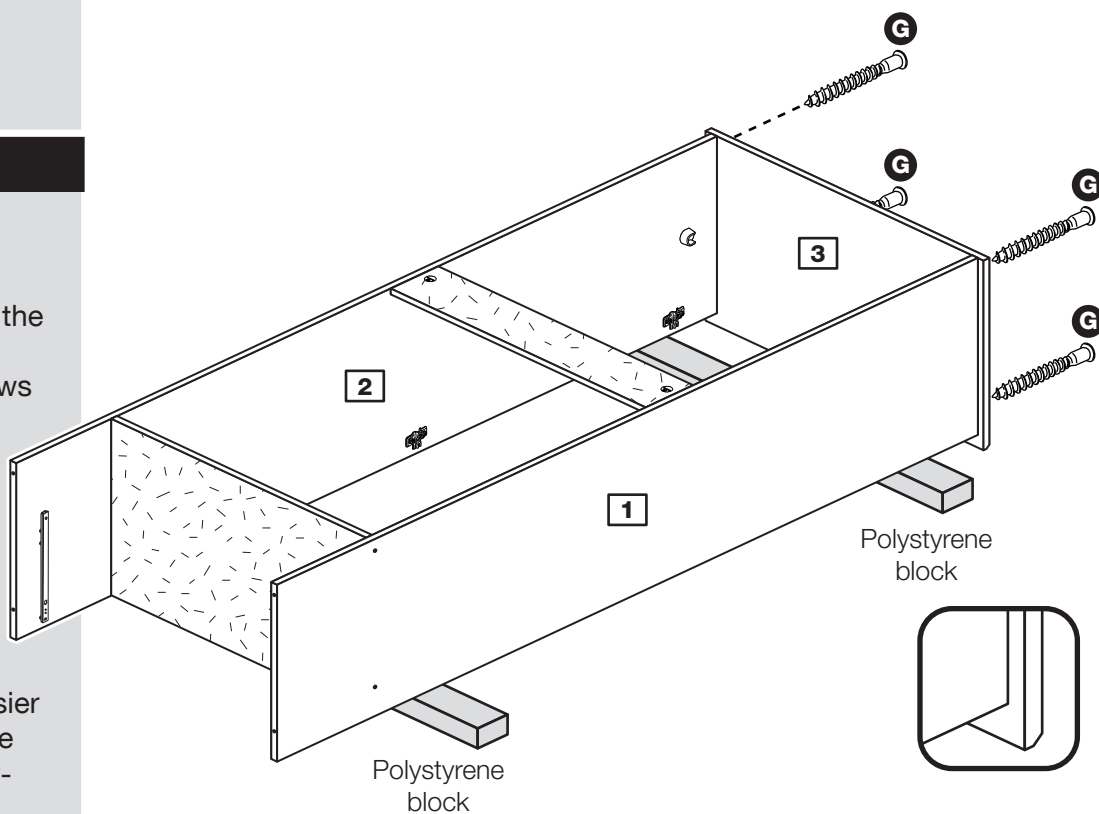

Assembly Instructions

Step 15

Fit the base

Attach the base **4** to the left side **1** and right side **2** using 4 screws **G**.

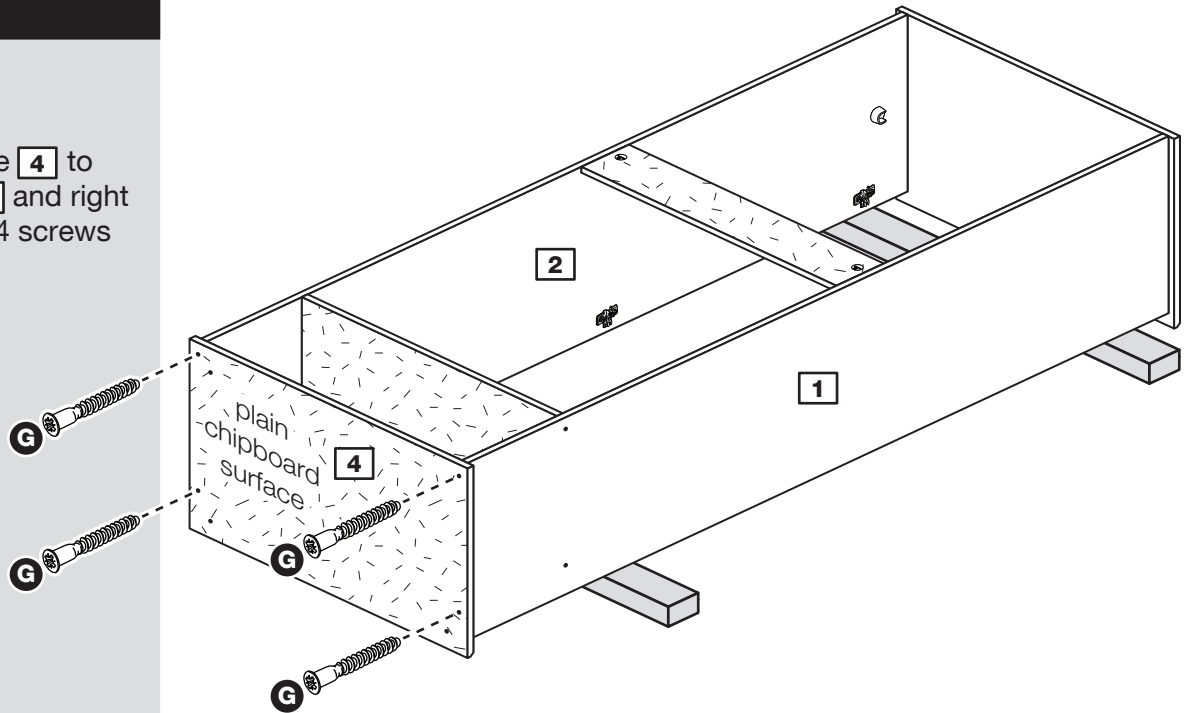

Step 16

Fit the feet

Fit the 4 feet **K** to the base **4** using 4 screws **G**.

Note: You may find it easier to turn the foot as the screw is held with the screwdriver.

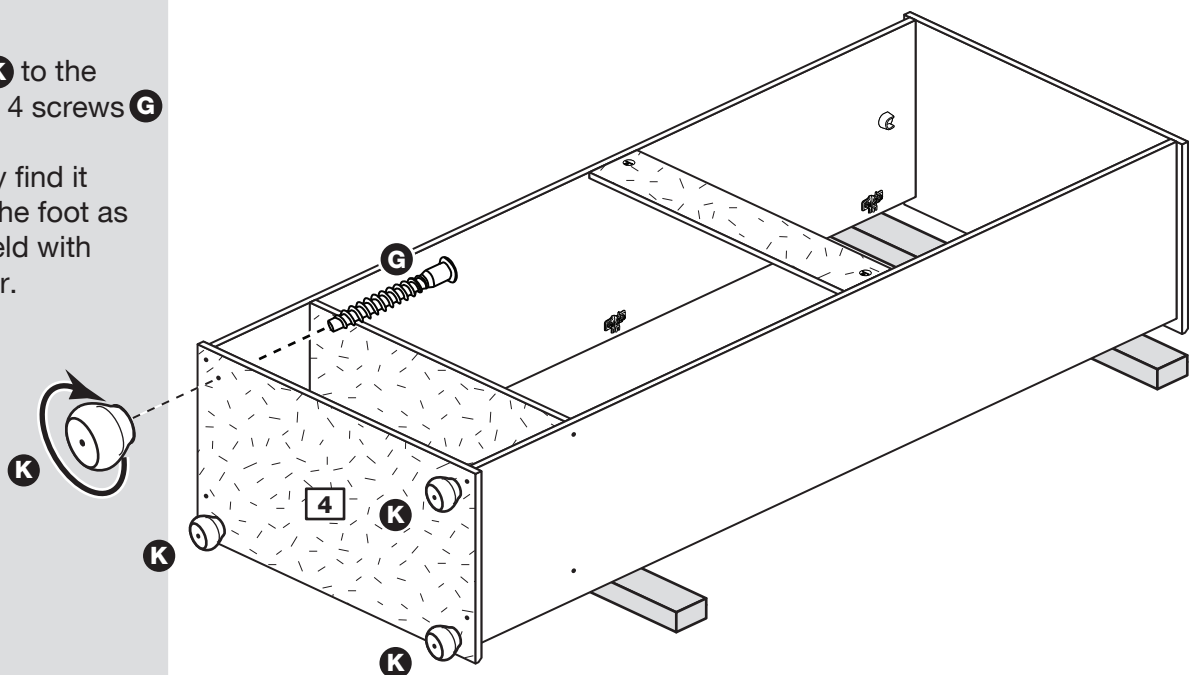

Assembly Instructions

Step 17

Fit the back

a: Square up the unit by making sure that measurement **x** to **x** equals **y** to **y**.

b: Place the back **14** onto the unit.

Nail **E** around the outside edges of the back **14**.

Note: Nails should be spaced about 150mm apart.

Stand the unit up for the next step.



Warning: The unit is heavy. Lift with care.

a: The measurement from top corner X to bottom corner X must be equal to the measurement from top corner Y to bottom corner Y

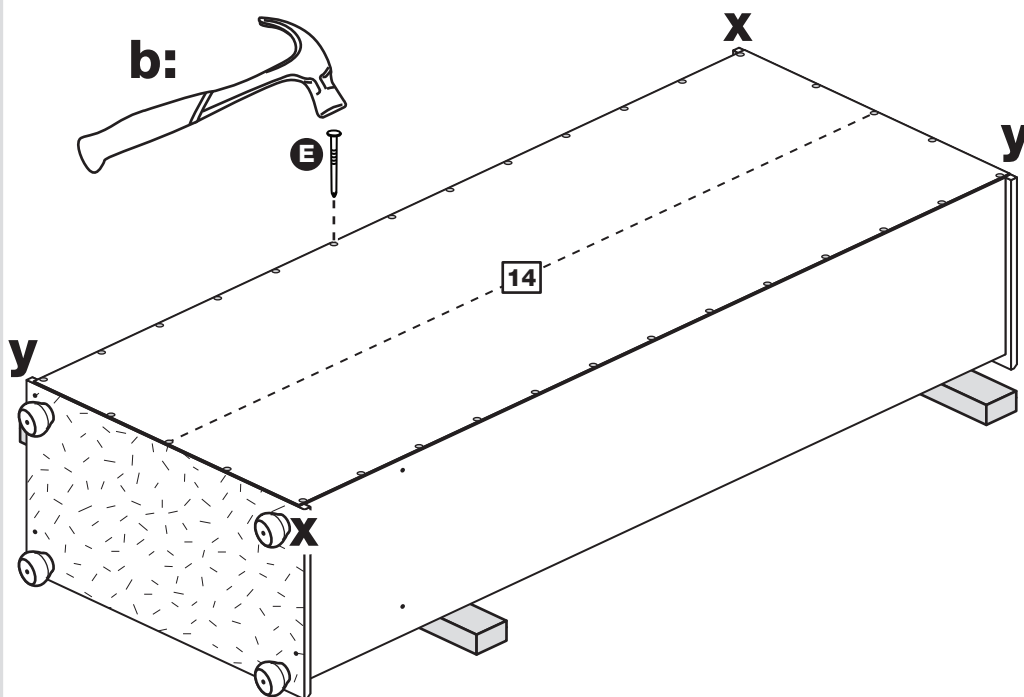

Step 18

Fit the drawers

Slide both the runners **S** forward and locate the drawer sides **8** and **9** between them, lining up the holes in the drawer sides with the 2nd 'threaded' holes in the runners **S**.

Working from the inside of the drawer, insert 2 screws **J** through the drawer sides and out into the 2nd threaded hole in the runner.

Note: Do not overtighten the screws **J**. If they catch on the runner you may need to loosen them slightly.

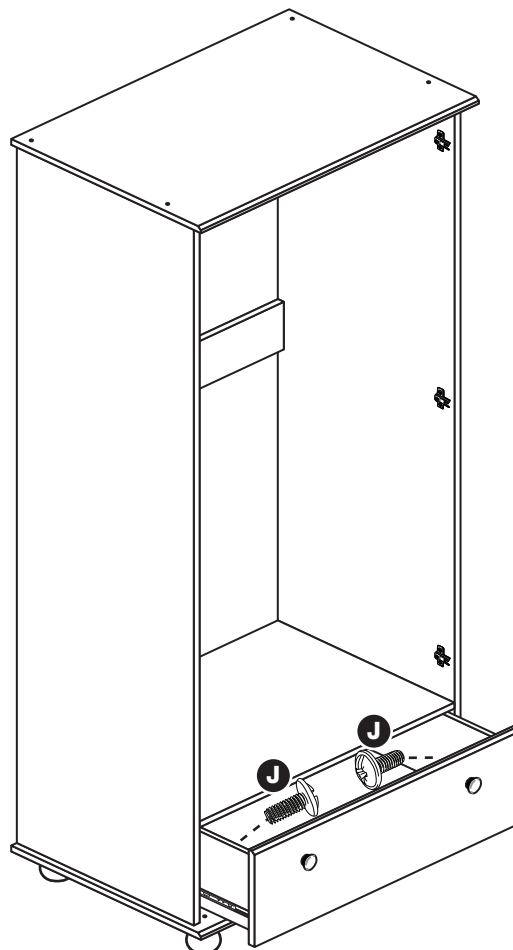
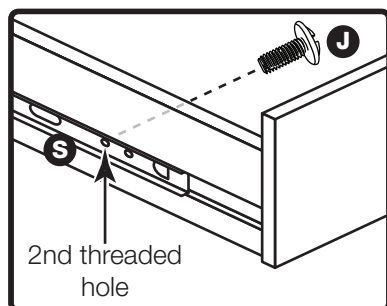

Assembly Instructions

Step 19

Fit the hanging rail

Push hanging rail **11** into the rail holders **N** fitted to the side panels.

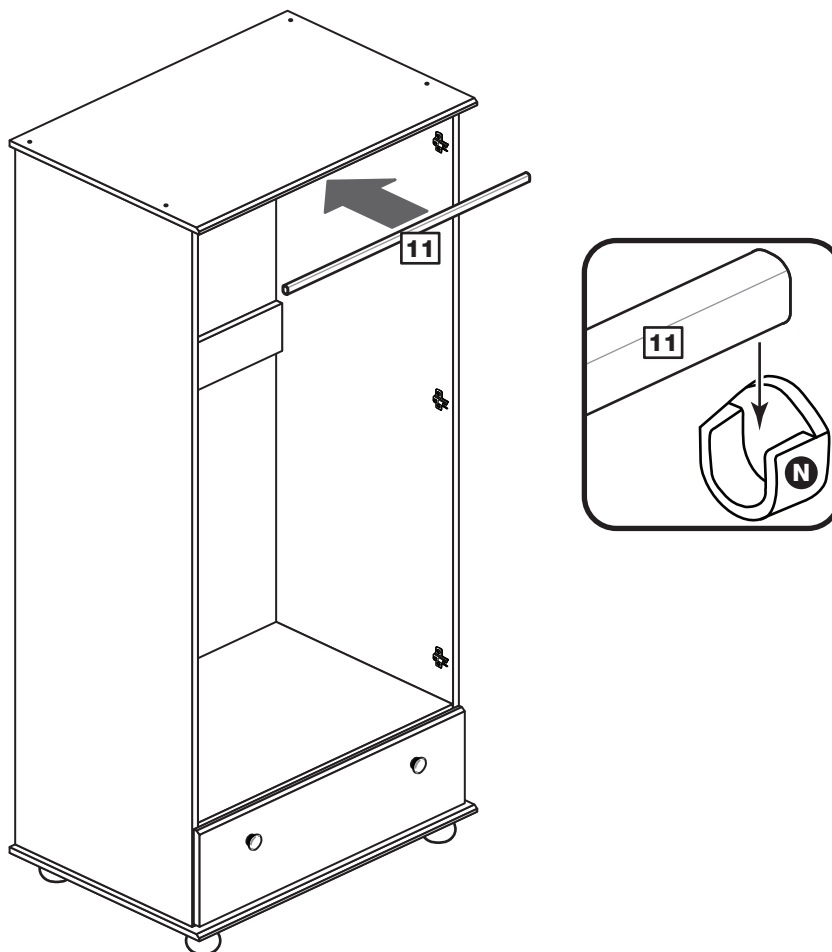

Step 20

Prepare the 2 doors

Push fit 3 hinges **Q** into each of the 2 doors **13**.

Secure each hinge with 2 screws **L**.

Note: Before securing with the screws, make sure that the hinges are positioned at 90 degrees with the edge of the door.

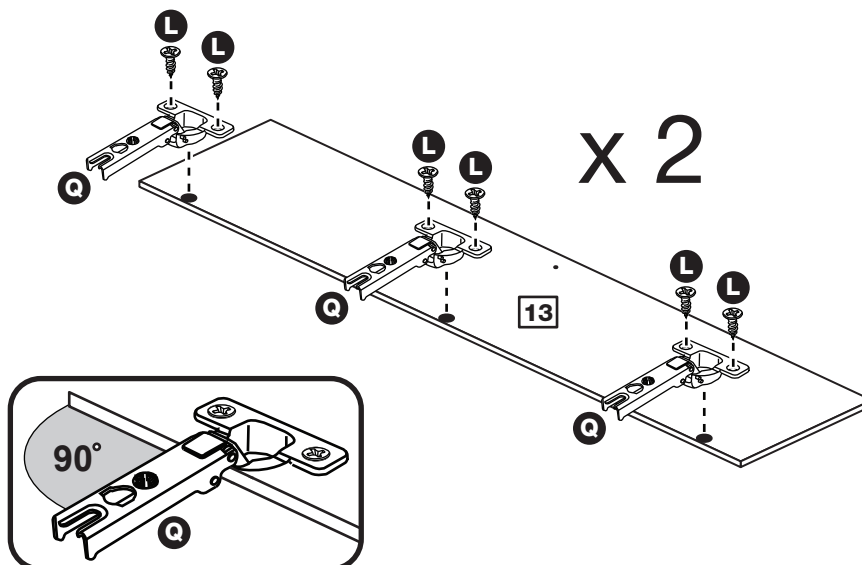

Assembly Instructions

Step 21

Fit doors and handles

Note: The easiest way to attach each door **13** is to fit the top hinge first, then align and fit the other hinges.

a: Push the hinge **Q** onto the front part of the hinge plate **P**. The recess at the bottom of screw B goes into the slot in the hinge plate.

b: Keep the hinge **Q** FLAT against the hinge plate **P** as you slide it across as far as it will go. Tighten screw A.

c: The hinge **Q** must be flat against the hinge plate **P** prior to any adjustment.

d: The hinge **Q** must NOT be AT AN ANGLE to the hinge plate **P** when assembled. This would indicate that the recess at the bottom of screw B had not located in the slot in the hinge plate and the hinge would not be secure. Remove the hinge from the hinge plate and then re-assemble being careful to follow instructions a-c.

e: Attach a handle **O** to each door **13** using screw **H**.

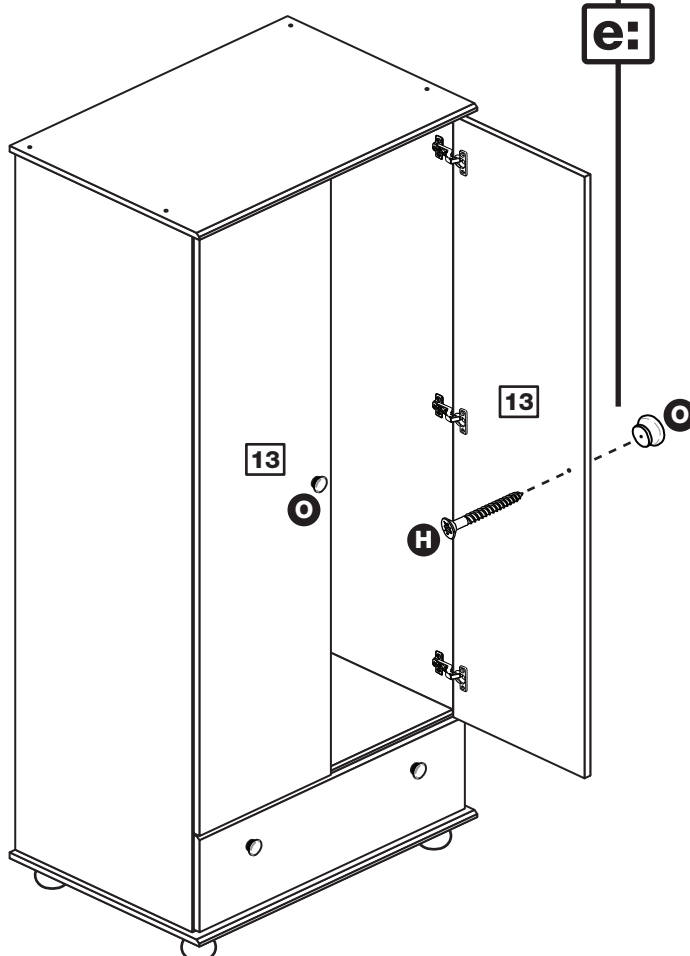
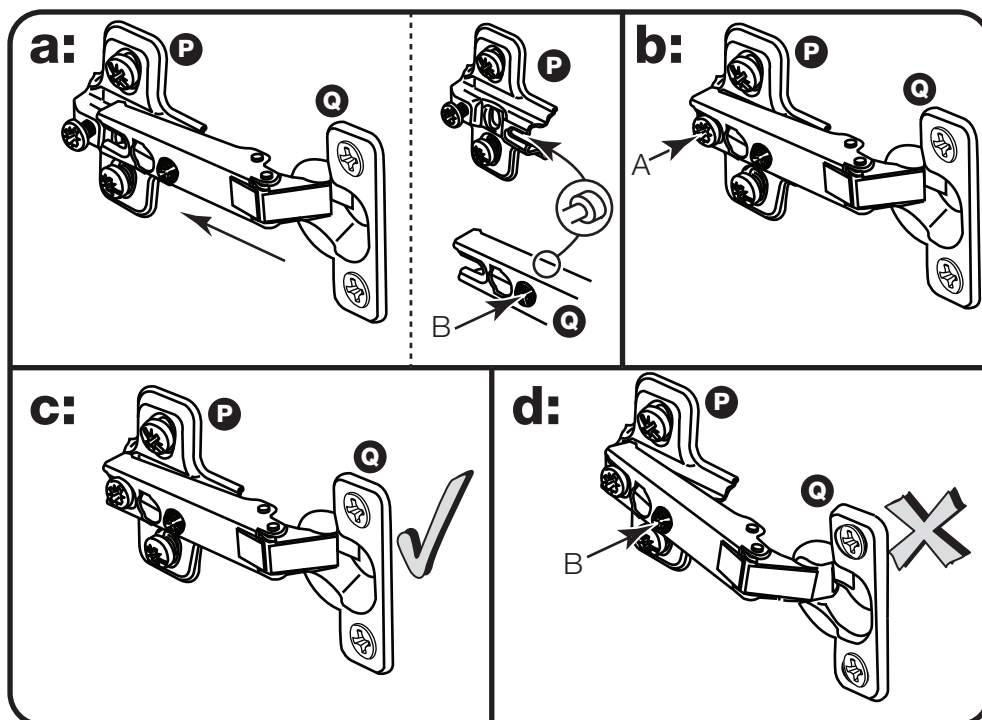

Assembly Instructions

Step 22

Adjust the doors if needed

a: Before adjusting the doors, use a spirit level to check the base (or top) of the unit is level, front-to-back and side-to-side in the 3 positions shown. Use suitable packing pieces (not supplied) to make the unit level BEFORE making any adjustment to the hinges, as shown.

b: Height adjustment.

Loosen screws A on hinge plates and move door up or down as required. Retighten screw A.

c: Forward and Back adjustment.

Loosen screw B on hinge plate and move door in or out as required. Retighten screw B.

d: Sideways adjustment.

To move door 'out' loosen screw C. To move door 'in' tighten screw C.

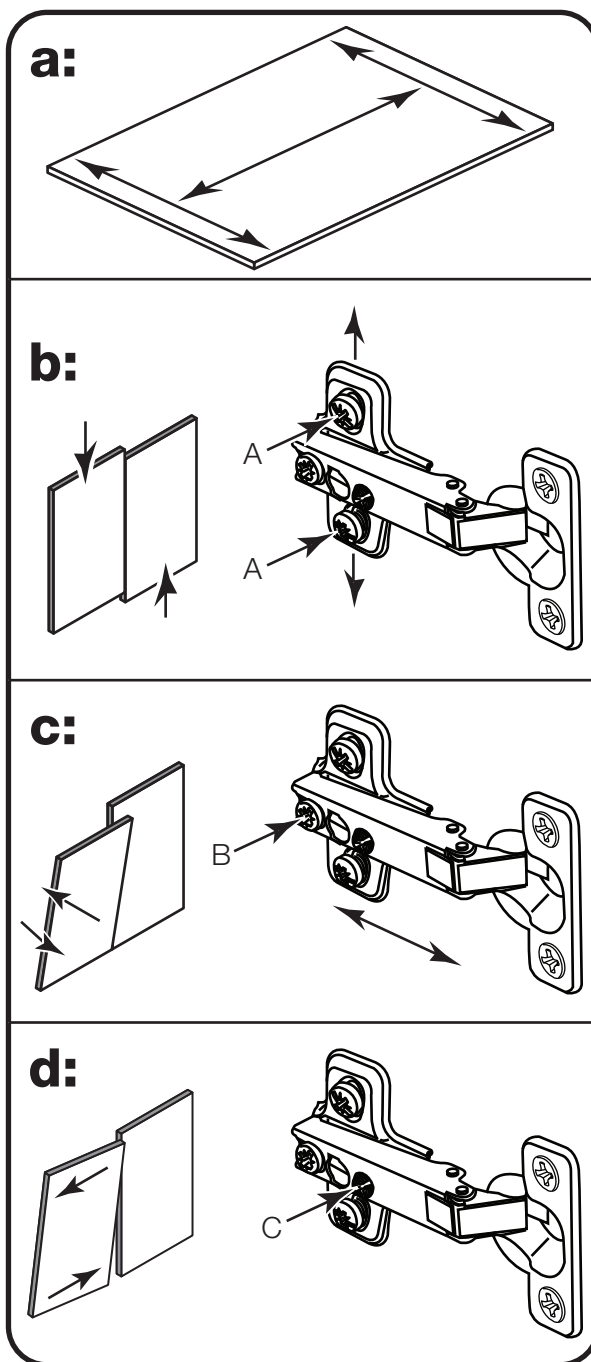

Assembly Instructions

Step 23

Fit the overbalance protector

To prevent possible overbalancing we recommend that this unit is secured to a suitable wall by use of the overbalance protector kit **R** fitted to the unit or, an alternative fixing method of your choice.

Wall fixings are not supplied as they will need to suit the wall type.

Note: Take care when drilling the wall that you do not drill into any pipes, wires etc. If in doubt, consult an expert.



Warning: The unit is heavy. Lift with care.

Assembly is complete

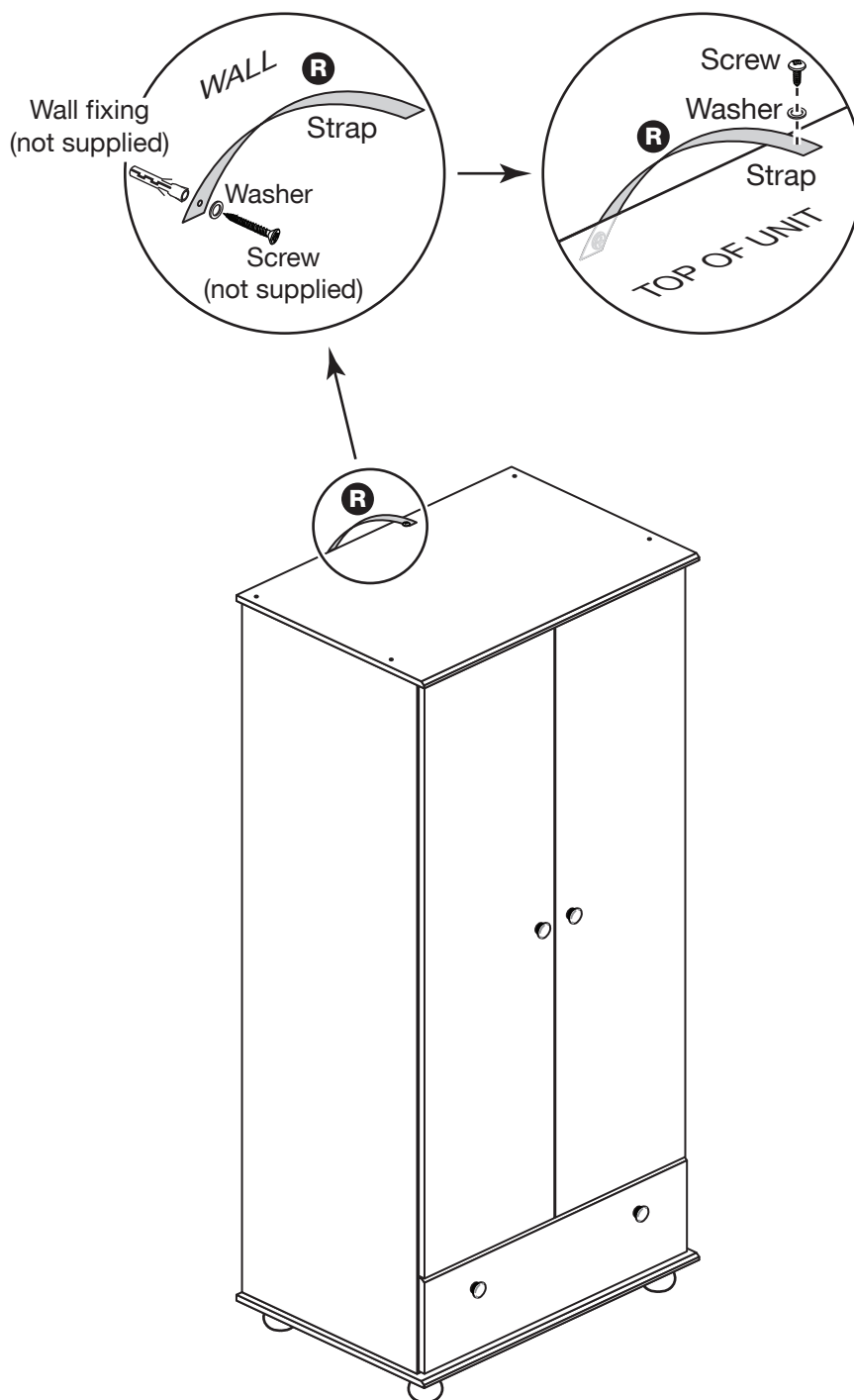

If you need help or have damaged or missing parts, call the Customer Helpline: 08456 400800 and quote the reference numbers on the component pages.

Argos Ltd, 489-499 Avebury Boulevard, Central Milton Keynes, MK9 2NW

Stirling - 2 Drawer Bedside

Assembly Instructions - Please keep for future reference

355/8243

356/5470

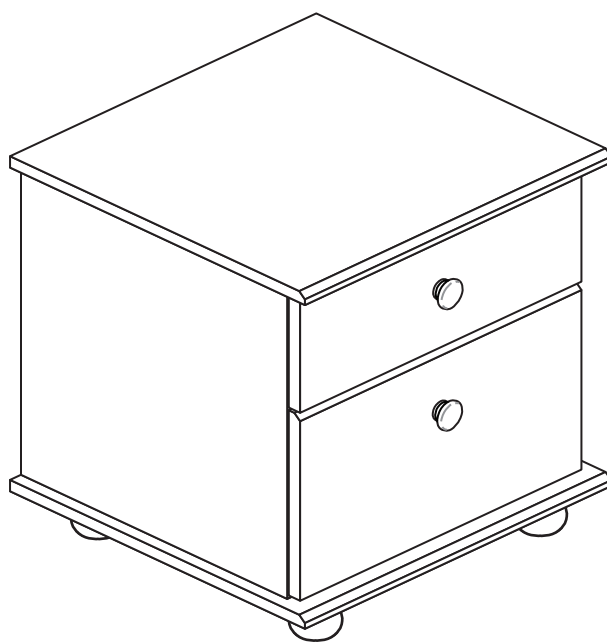

Dimensions

Width - 40.5cm

Depth - 39cm

Height - 49.5cm



**MADE IN
BRITAIN**

Important - Please read these instructions fully before starting assembly

If you need help or have damaged or missing parts, call the **Customer Helpline: 08456 400800**



Safety and Care Advice

Important - Please read these instructions fully before starting assembly

- **Warning:** This unit weighs approximately 12.5kgs. Please lift with care.

- Check you have all the components and tools listed on pages 2 and 3.

- Remove all fittings from the plastic bags and separate them into their groups.

- Keep children and animals away from the work area, small parts could choke if swallowed.

- Parts of the assembly will be easier with 2 people.

- Make sure you have enough space to layout the parts before starting.

- Do not stand or put weight on the product, this could cause damage.

- Assemble the item as close to its final position (in the same room) as possible.

- Assemble on a soft level surface to avoid damaging the unit or your floor (use opened out unit carton).



- We do not recommend the use of power drill/drivers **for inserting screws**, as this could damage the unit. Only use hand screwdrivers.

- **Safety note:** If there is any chance of this unit being pulled over by children etc. it is recommended that the unit is secured to a wall using suitable fixings (not supplied).

- Dispose of all packaging carefully and responsibly.

Care and maintenance

- Only clean using a damp cloth and mild detergent, do not use bleach or abrasive cleaners.

- From time to time check that there are no loose screws on this unit.

- This product should not be discarded with household waste. Take to your local authority waste disposal centre.

Note: If required the next page can be cut out and used as reference throughout the assembly. Keep this page with these instructions for future reference.

Components - Panels

If you have damaged or missing components, call the
Customer Helpline: 08456 400800 quoting the reference
 numbers below

Please check you have all the panels listed below

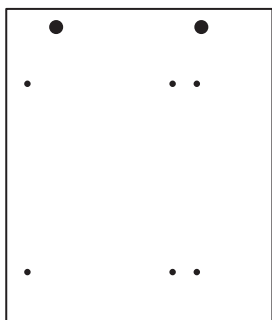

1 Left Side (D2991A)
 (413 x 352mm)

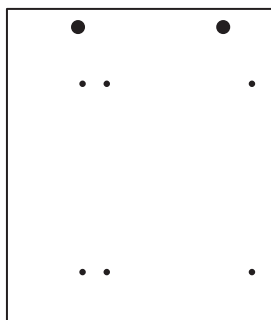

2 Right Side (D2992A)
 (413 x 352mm)

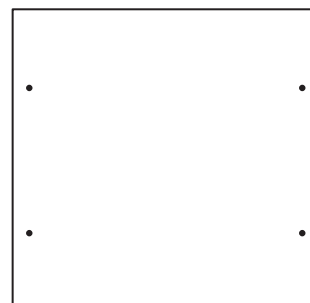

3 Top (D2990A)
 (405 x 390mm)

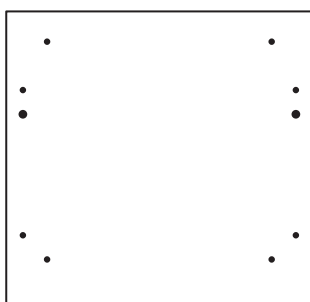

4 Base (D2993B)
 (405 x 390mm)

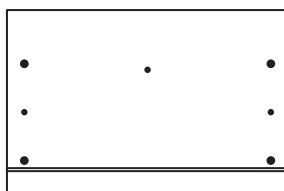

5 Large Drawer Front (D2995A)
 (372 x 245mm)

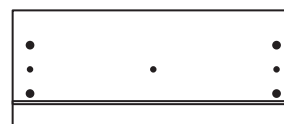

6 Small Drawer Front (D2994A)
 (372 x 156mm)

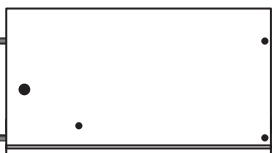

7 Large Left Drawer
 Side (W350-195LH)
 (350 x 195mm)

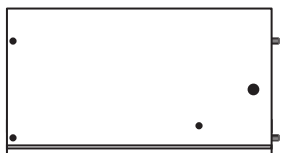

8 Large Right Drawer
 Side (W350-195RH)
 (350 x 195mm)



9 Large Drawer
 Back (W313-195)
 (313 x 195mm)

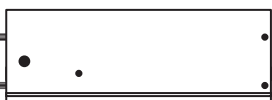

10 Small Left Drawer
 Side (W350-124LH)
 (350 x 124mm)

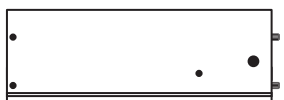

11 Small Right Drawer
 Side (W350-124RH)
 (350 x 124mm)

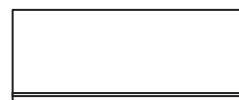

12 Small Drawer
 Back (W313-124)
 (313 x 124mm)

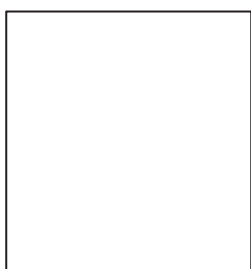

13 Drawer Base (T324-347)
 (324 x 347mm) x 2



14 Back (X439-372)
 (439 x 372mm)











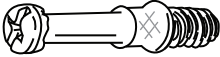



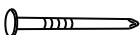

Components - Fittings

If you have damaged or missing components, call the **Customer Helpline: 08456 400800** quoting the reference numbers below

Please check you have all the fittings listed below

Note: The quantities below are the correct amount to complete the assembly. In some cases more fittings may be supplied than are required.

<p>A </p> <p>Metal dowel (F901) x 8</p>	<p>B </p> <p>Large locking nut (F900) x 4</p>	<p>C </p> <p>Small locking nut (F3) x 4</p>
<p>D </p> <p>Wooden dowel (F22) x 2</p>	<p>E </p> <p>Nail (F51) x 10</p>	<p>F </p> <p>Knock-in Peg (F171GY) x 8</p>
<p>G </p> <p>40mm Screw (F910) x 8</p>	<p>H </p> <p>38mm Screw (F81) x 2</p>	<p>I </p> <p>9mm Screw (F73) x 8</p>
<p>J </p> <p>9mm Screw (F74) x 4</p>	<p>K </p> <p>Wedgex (F639) x 4</p>	<p>L </p> <p>Handle (F463) x 2</p>
<p>M </p> <p>Drawer runner (F1004) x 4</p>		<p>N </p> <p>Foot (F340) x 4</p>

Tools required

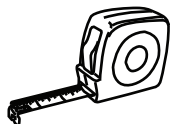

Rule



Cross-head screwdriver



Scissors



Hammer



Eye protection (when using a hammer or drill)

Ruler - Use this ruler to help correctly identify the screws

mm 10 20 30 40 50 60 70 80 90 100 110 120 130 140 150 160 170

Assembly Instructions

If you have damaged or missing components, call the
Customer Helpline: 08456 400800 quoting the reference
numbers below

Step 1

Prepare the large drawer front

Screw 2 metal dowels **A**
into the large drawer
front **5**.

Note: Tighten the metal
dowels up fully against
the panels.

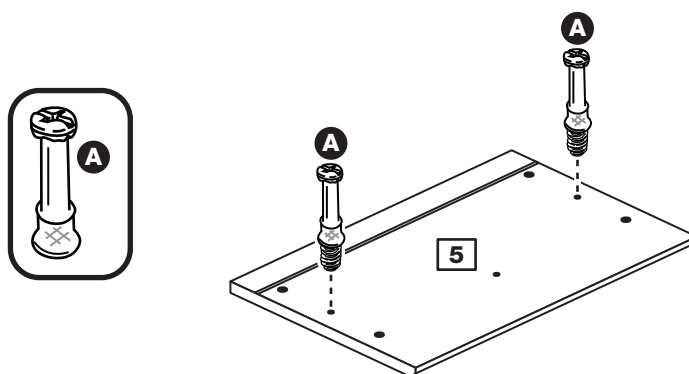

Step 2

Prepare the large drawer sides

Insert a small locking
nut **C** into the hole
shown on the large left
drawer side **7** and the
large right drawer side
8.

Note: The arrow on the
locking nut **must** point
towards the hole in the
edge of the panel.

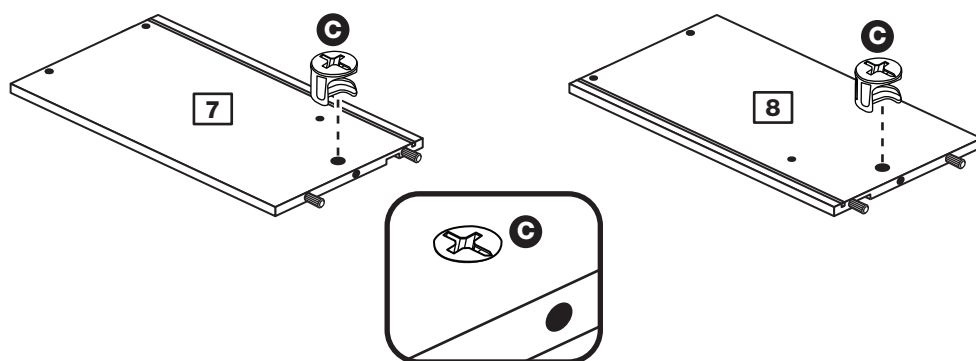

Step 3

Attach the large drawer sides to the large drawer front

Push the large left drawer
side **7** and large right
drawer side **8** onto the
back of the large drawer
front **5**.

Turn the small locking
nuts **C** on the large left
drawer side **7** and large
right drawer side **8**.

Note: Turn the locking
nuts **C** clockwise to
secure panels - more
than 1/2 a turn.

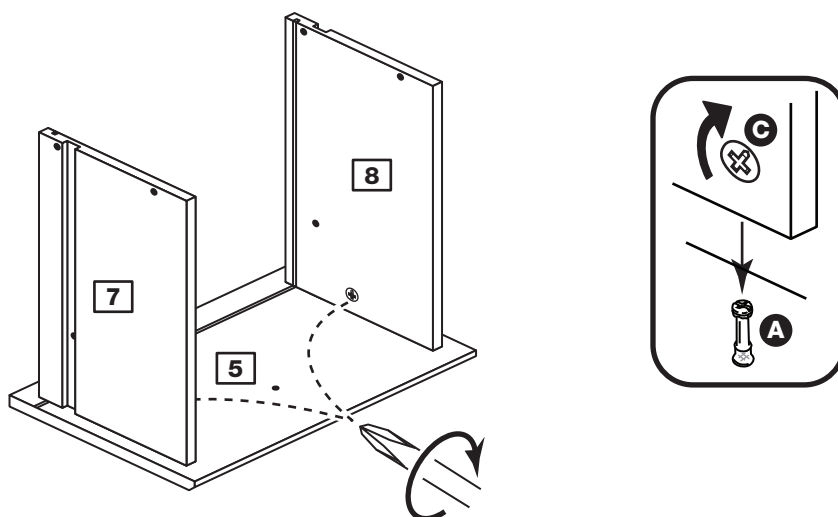

Assembly Instructions

Step 4

Fit the drawer base

Slide the drawer base **13** down the grooves in the large drawer sides **7** and **8** and down into the groove in the large drawer front **5**.

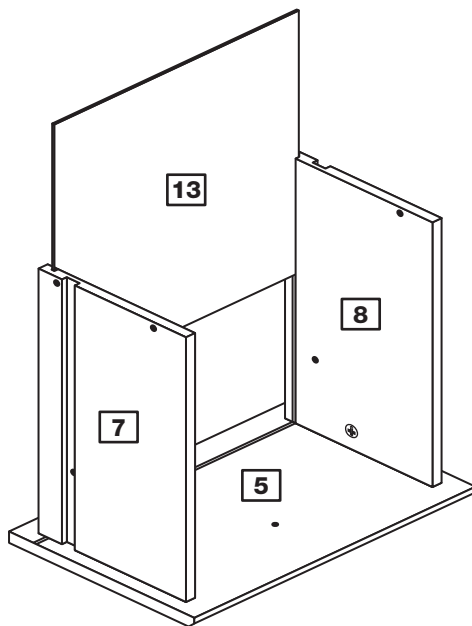

Step 5

Fit the large drawer back

Fit the large drawer back **9** between the large drawer sides **7** and **8**. Make sure that the drawer base **13** fits into the groove in the large drawer back **9**.

Hold the large drawer back **9** in position and tap the knock-in pegs **F** through the holes in the large drawer sides **7** and **8**.

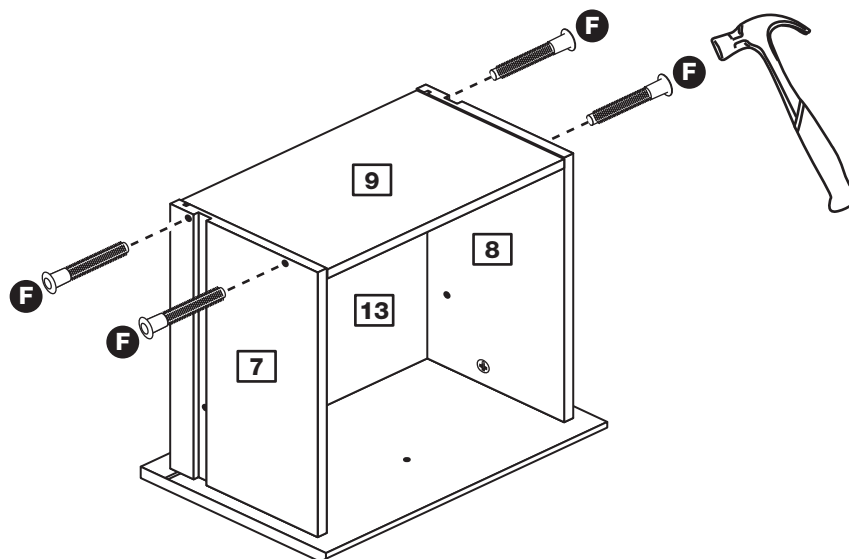

Step 6

Attach the handle

Attach a handle **L** to the large drawer front **5** using screw **H**.

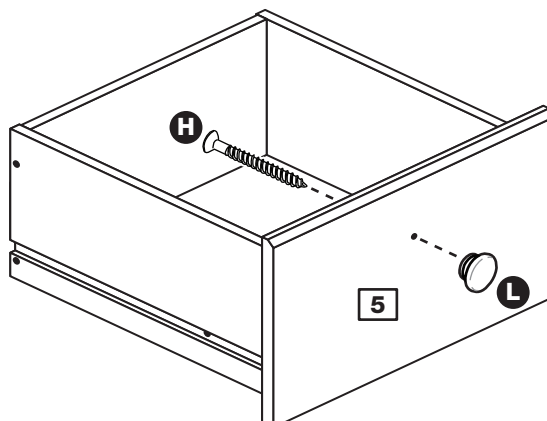

Assembly Instructions

Step 7

Fit the wedgexes

Turn the large drawer assembly over and slide 2 wedgexes **K** into the front and back grooves, as shown, and tighten up the screws.

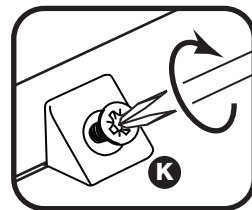
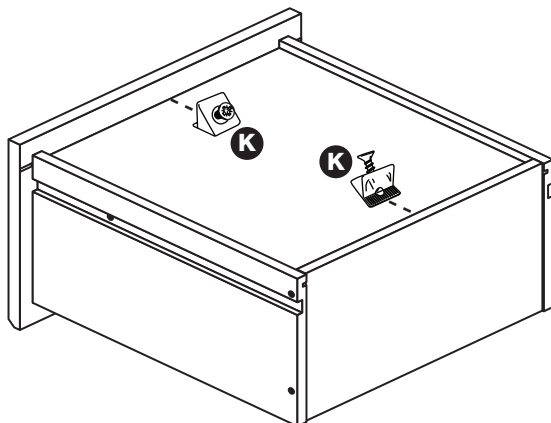

Step 8

Prepare the small drawer front

Screw 2 metal dowels **A** into the small drawer front **6**.

Note: Tighten the metal dowels up fully against the panels.

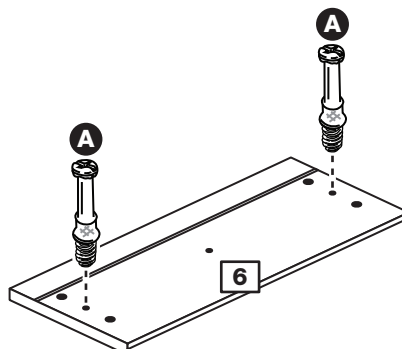
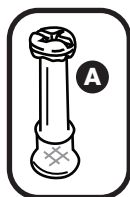

Step 9

Prepare the small drawer sides

Insert a small locking nut **C** into the hole shown on the small left drawer side **10** and the small right drawer side **11**.

Note: The arrow on the locking nut **must** point towards the hole in the edge of the panel.

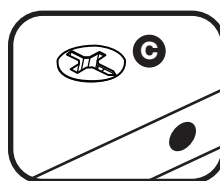
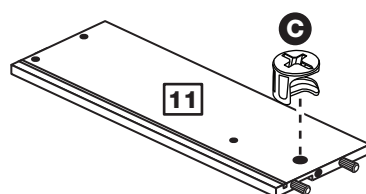
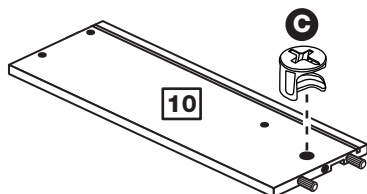

Assembly Instructions

Step 10

Attach the small drawer sides to the small drawer front

Push the small left drawer side **10** and small right drawer side **11** onto the back of the small drawer front **6**.

Turn the small locking nuts **C** on the small left drawer side **10** and small right drawer side **11**.

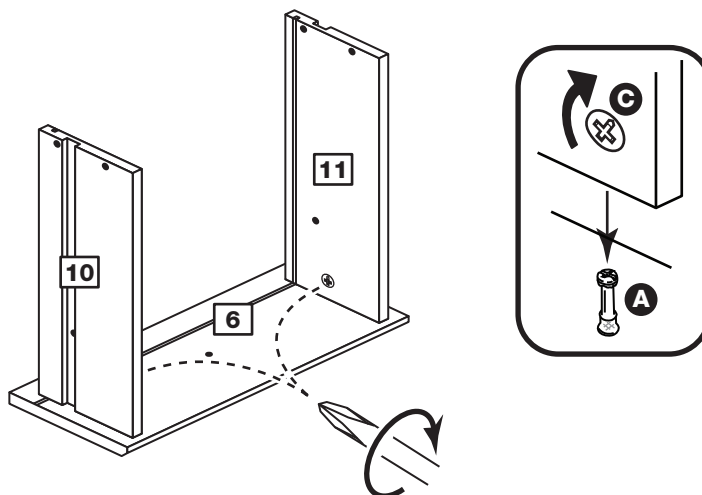

Step 11

Fit the drawer base

Slide the drawer base **13** down the grooves in the small drawer sides **10** and **11** and down into the groove in the small drawer front **6**.

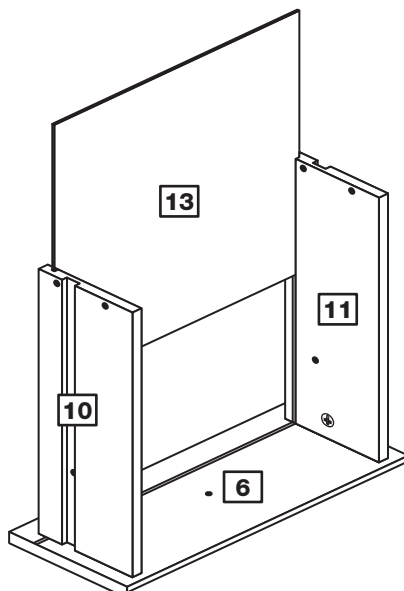

Step 12

Fit the small drawer back

Fit the small drawer back **12** between the small drawer sides **10** and **11**. Make sure that the small drawer base **13** fits into the groove in the small drawer back **12**.

Hold the small drawer back **12** in position and tap the knock-in pegs **F** through the holes in the small drawer sides **10** and **11**.

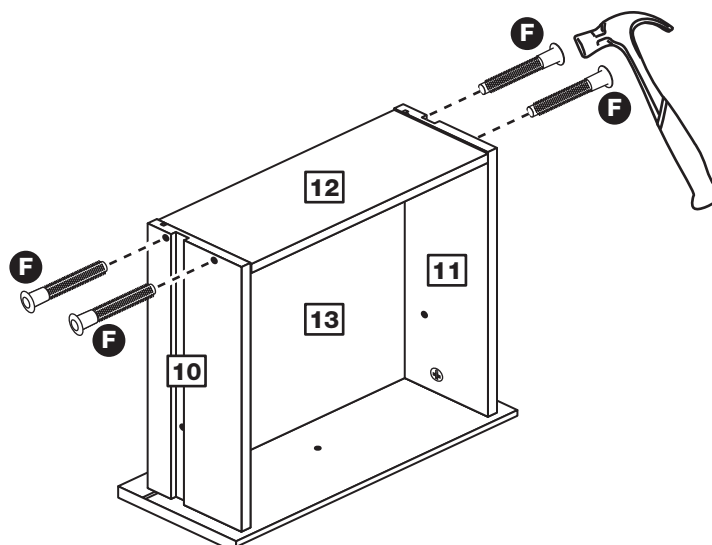

Assembly Instructions

Step 13

Attach the handle

Attach a handle **L** to the small drawer front **6** using screw **H**.

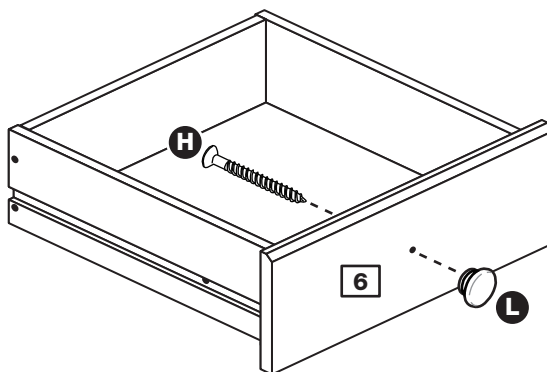

Step 14

Fit the wedgexes

Turn the small drawer assembly over and slide 2 wedgexes **K** into the front and back grooves, as shown, and tighten up the screws.

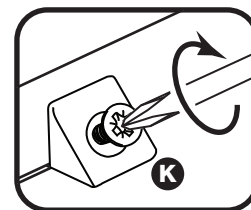
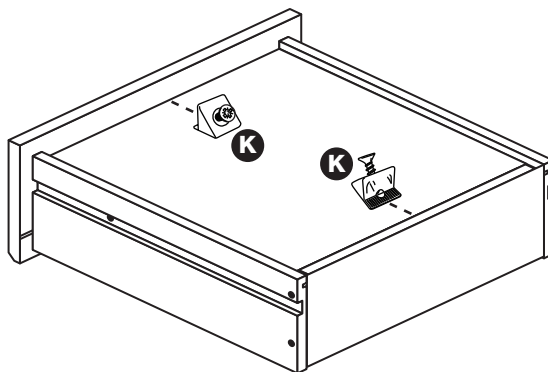

Step 15

Prepare the top

Screw 4 metal dowels **A** into the top **3**.

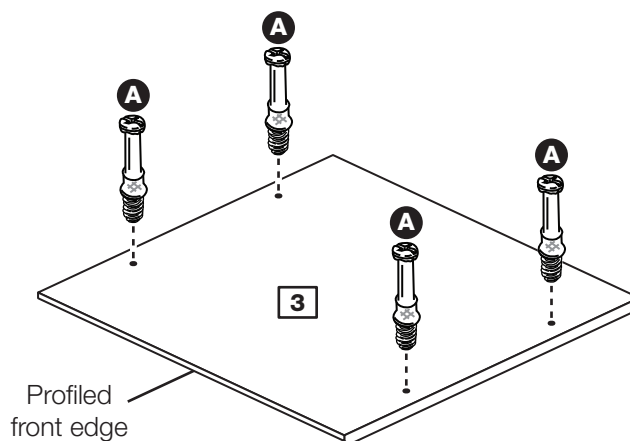

Assembly Instructions

Step 16

Prepare the left side

a: Place 2 runners **M** on the left side **1**. Slide back the top of runner and use the 2nd hole from the front to fit the 1st screw **I**.

b: Slide the runner **M** back the other way and fit the 2nd screw **I** into the corresponding hole in the left side **1**.

c: Insert 2 large locking nuts **B** into the left side **1**.

Note: The arrow on the locking nut **must** point towards the hole in the edge of the panel.

Tap a wooden dowel **D** into the left side **1**.

Note: Wooden dowels **must not** stick out from the edge by more than 10mm or they may damage other panels.

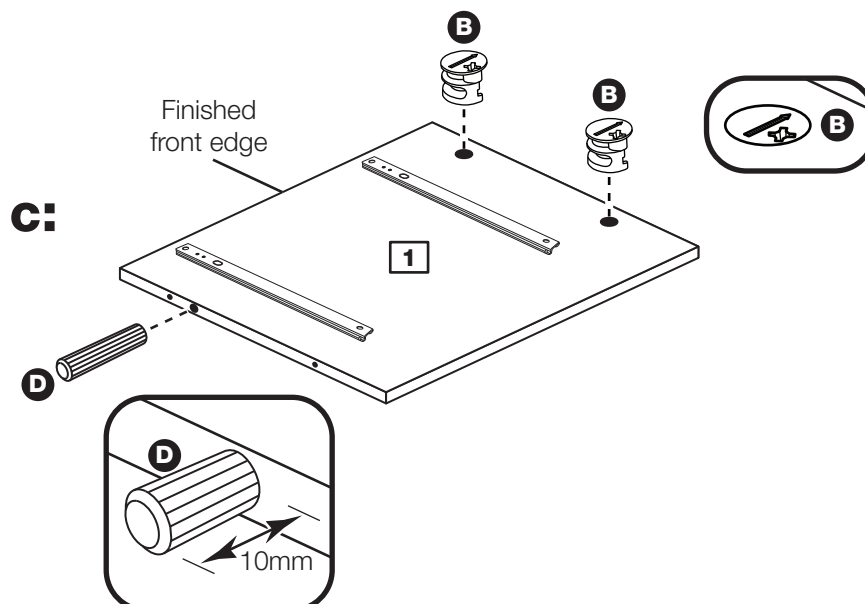
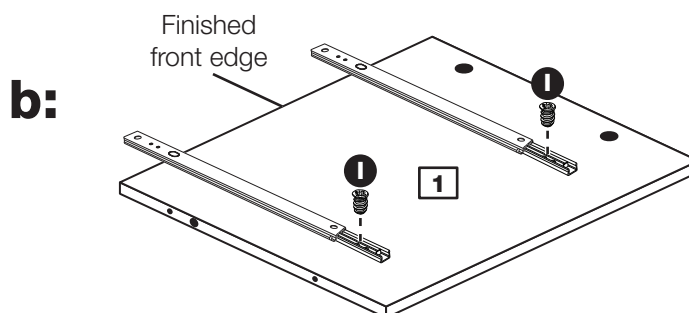
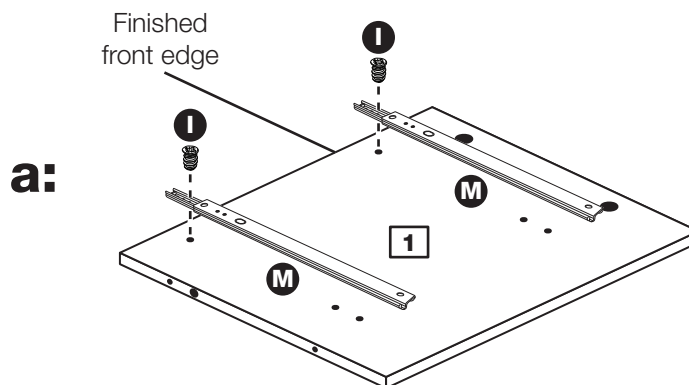
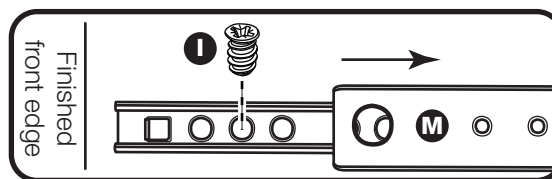

Assembly Instructions

Step 17

Prepare the right side

a: Place 2 runners **M** on the right side **2**. Slide back the top of runner and use the 2nd hole from the front to fit the 1st screw **I**.

b: Slide the runner **M** back the other way and fit the 2nd screw **I** into the corresponding hole in the right side **2**.

c: Insert 2 large locking nuts **B** into the right side **2**.

Tap a wooden dowel **D** into the right side **2**.

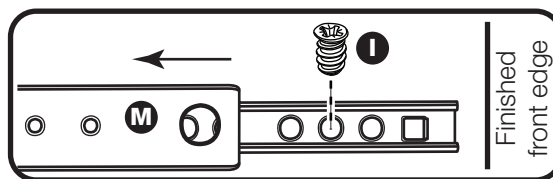

a:

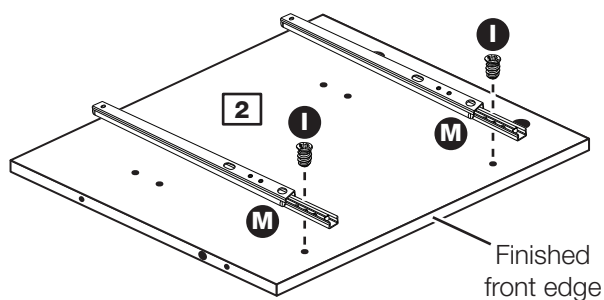

b:

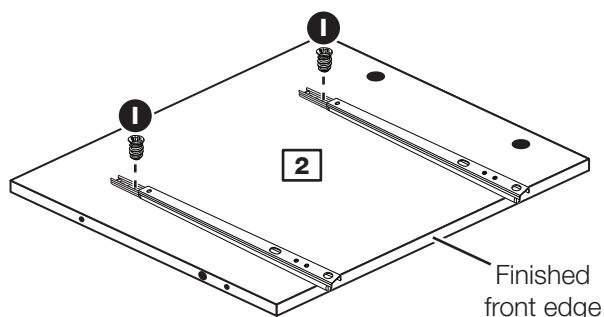

c:

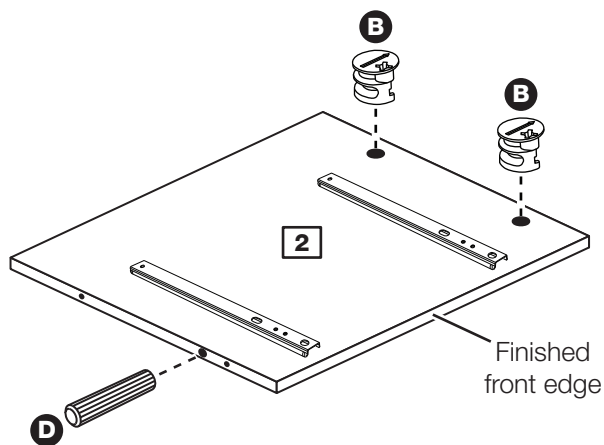

Assembly Instructions

Step 18

Join the top and right side

Push the right side **2** onto the top **3**.

Use a screwdriver to tighten the 2 large locking nuts **B** fitted to the right side **2**.

Note: Turn the large locking nuts **B** as far as they will go - more than 1/2 a turn.

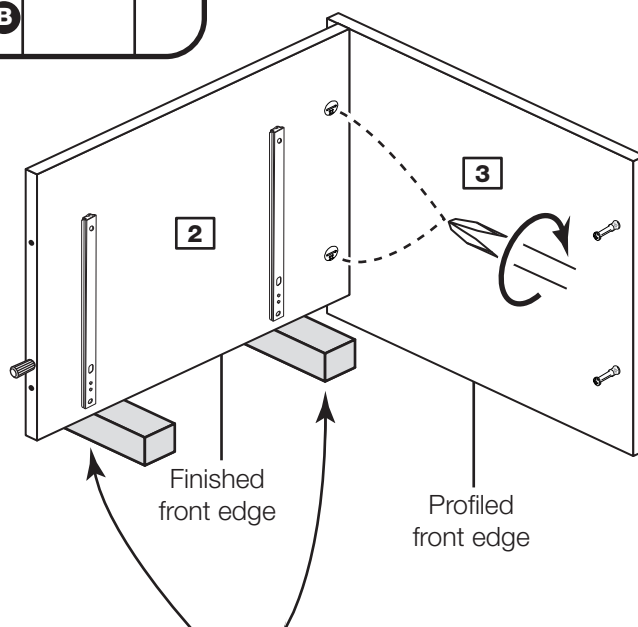
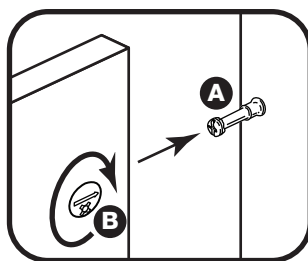

Note: To make it easier to fit the top and base panels, place polystyrene blocks from the packaging underneath the side panels to raise the assembly.

Step 19

Join the left side

Push the left side **1** onto the top **3**.

Use a screwdriver to tighten the 2 large locking nuts **B** fitted to the left side **1**.

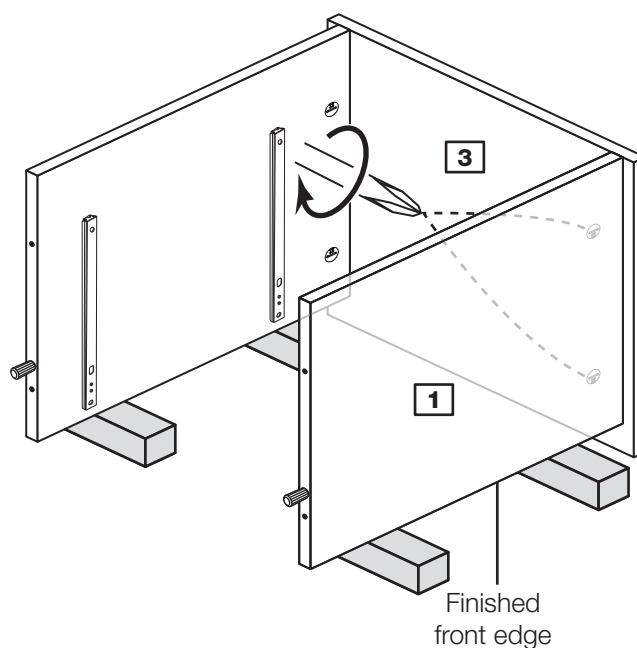

Assembly Instructions

Step 20

Fit the base

Attach the base **4** to the left side **1** and right side **2** using 4 screws **G**.

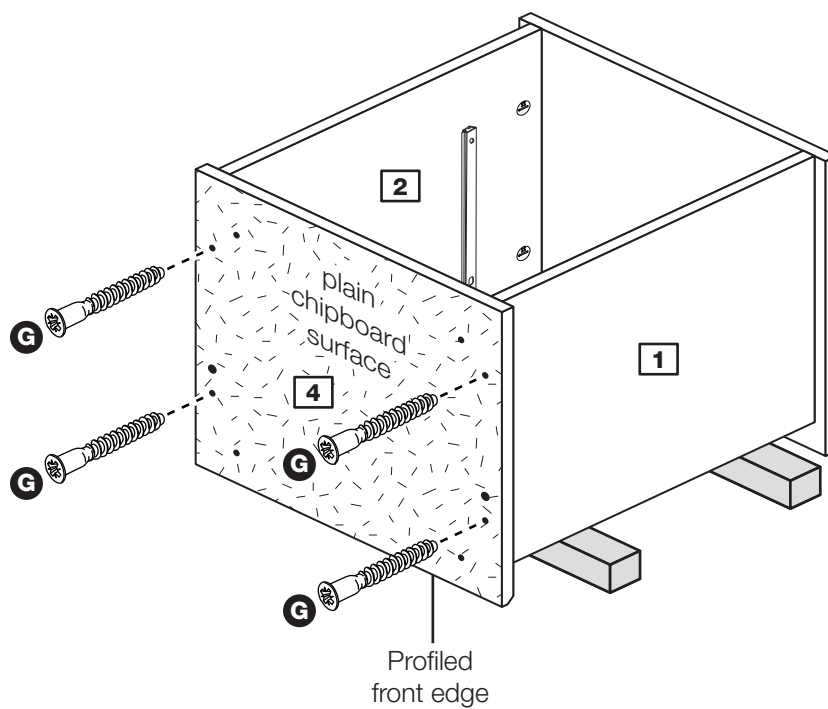

Step 21

Fit the feet

Fit the 4 feet **N** to the base **4** using screws **G**.

Note: You may find it easier to turn the foot as the screw is held with the screwdriver.

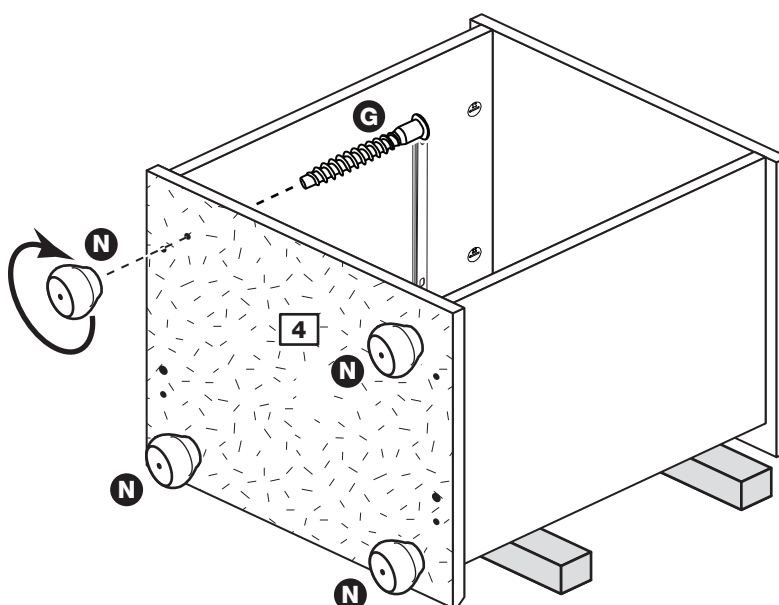

Assembly Instructions

Step 22

Fit the back

a: Square up the unit by making sure that measurement **x to x** equals **y to y**.

b: Place the back **14** onto the unit.

Nail **E** around the outside edges of the back **14**.

Note: Nails should be spaced out evenly.

Stand the unit up for the next step.

a: The measurement from top corner X to bottom corner X must be equal to the measurement from top corner Y to bottom corner Y

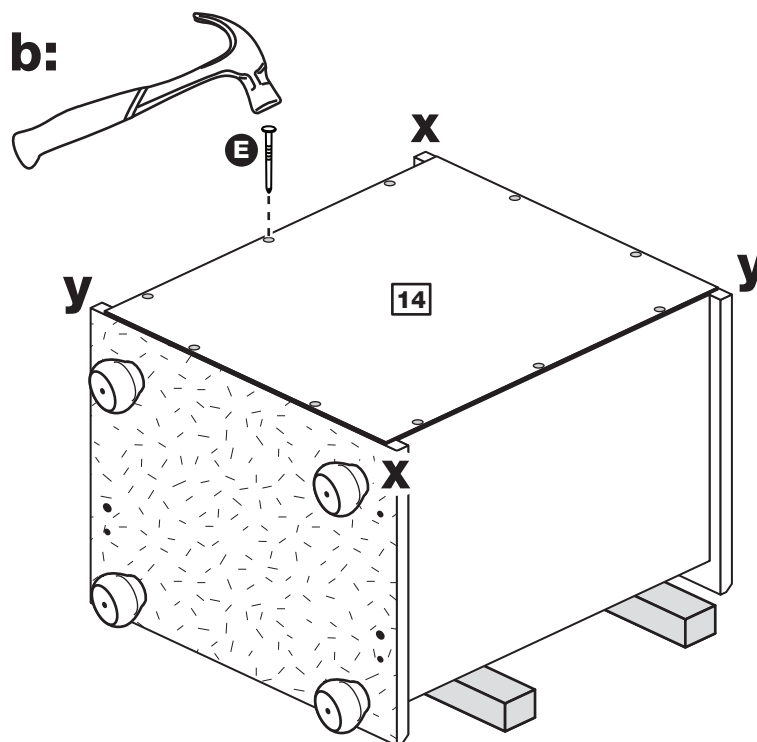

Assembly Instructions

Step 23

Fit the drawers

Starting with the large bottom drawer, slide both the runners **M** forward and locate the drawer sides between them, lining up the holes in the drawer wrap with the 2nd 'threaded' holes in the runners **M**.

Working from the inside of the drawer, insert 2 screws **J** through the drawer sides and out into the 2nd threaded hole in the runner.

Note: Do not overtighten the screws **J**. If they catch on the runner you may need to loosen them slightly.

Assembly is complete

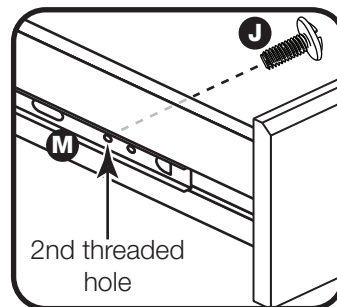
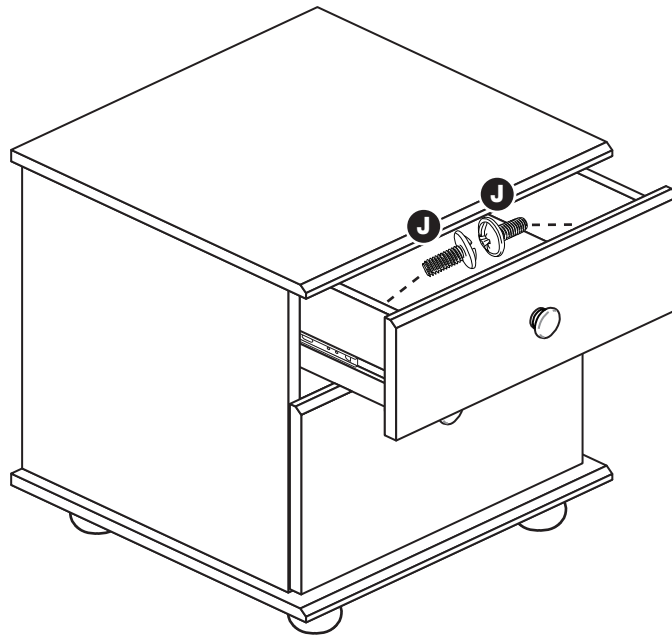

If you need help or have damaged or missing parts, call the Customer Helpline: 08456 400800 and quote the reference numbers on the component pages.

Argos Ltd, 489-499 Avebury Boulevard, Central Milton Keynes, MK9 2NW

Stirling - 4 Drawer Chest

Assembly Instructions - Please keep for future reference

357/4681

359/1994



Dimensions

Width - 72cm

Depth - 39cm

Height - 86.5cm



**MADE IN
BRITAIN**

Important - Please read these instructions fully before starting assembly

If you need help or have damaged or missing parts, call the **Customer Helpline: 08456 400800**



Safety and Care Advice

Important - Please read these instructions fully before starting assembly

- **Warning:** This unit weighs approximately 27kgs. Please lift with care.

- Check you have all the components and tools listed on pages 1, 2 and 3.

- Remove all fittings from the plastic bags and separate them into their groups.

- Keep children and animals away from the work area, small parts could choke if swallowed.

- Parts of the assembly will be easier with 2 people.

- Make sure you have enough space to layout the parts before starting.

- Do not stand or put weight on the product, this could cause damage.

- Assemble the item as close to its final position (in the same room) as possible.

- Assemble on a soft level surface to avoid damaging the unit or your floor (use opened out unit carton).



- We do not recommend the use of power drill/drivers **for inserting screws**, as this could damage the unit. Only use hand screwdrivers.

- **Safety note:** It is recommended that this unit is secured to a wall using the bracket supplied.

- Dispose of all packaging carefully and responsibly.

Care and maintenance

- Only clean using a damp cloth and mild detergent, do not use bleach or abrasive cleaners.

- From time to time check that there are no loose screws on this unit.

- This product should not be discarded with household waste. Take to your local authority waste disposal centre.

Tools required

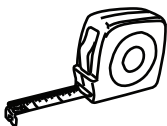

Rule



Cross-head screwdriver



Scissors



Hammer



Eye protection (when using a hammer or drill)



Electric drill (only use when drilling into walls)

Note: If required the next page can be cut out and used as reference throughout the assembly. Keep this page with these instructions for future reference.

Components - Panels

If you have damaged or missing components, call the **Customer Helpline: 08456 400800** quoting the reference numbers below

Please check you have all the panels listed below

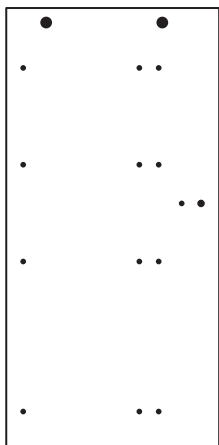

1 Left Side (D2997A)
(732 x 352mm)

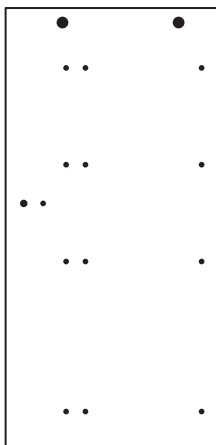

2 Right Side (D2998A)
(732 x 352mm)

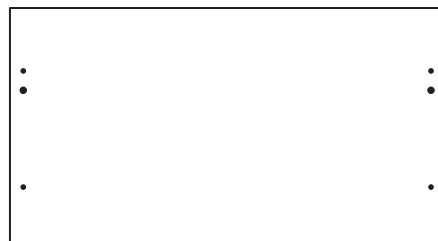

3 Top (D2996A)
(718 x 390mm)



4 Base (D2999B)
(718 x 390mm)



5 Back Rail (D3002A)
(659 x 96mm)

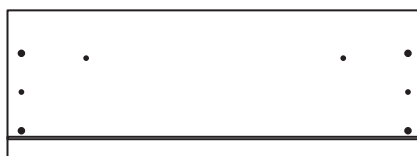

6 Large Drawer Front (D3000A)
(685 x 245mm)



7 Small Drawer Front (D3001A)
(685 x 156mm) x 3

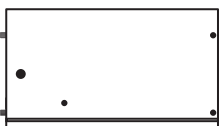

8 Large Left Drawer Side (W350-195LH)
(350 x 195mm)



9 Large Right Drawer Side (W350-195RH)
(350 x 195mm)



10 Large Drawer Back (W626-195)
(626 x 195mm)



11 Small Left Drawer Side (W350-124LH)
(350 x 124mm) x 3



12 Small Right Drawer Side (W350-124RH)
(350 x 124mm) x 3



13 Small Drawer Back (W626-124)
(626 x 124mm) x 3



14 Drawer Base (T637-347)
(637 x 347mm) x 4

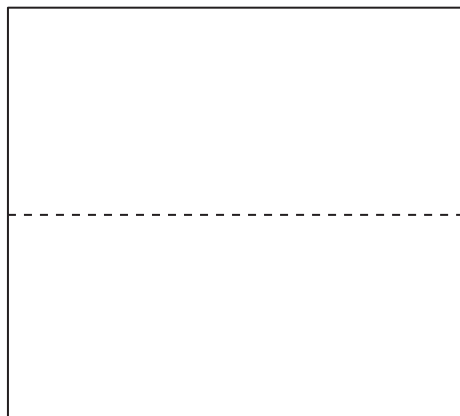

15 Back (X758-685)
(758 x 685mm)











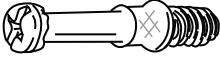



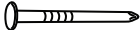



Components - Fittings

If you have damaged or missing components, call the **Customer Helpline: 08456 400800** quoting the reference numbers below

Please check you have all the fittings listed below

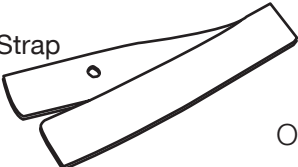
Note: The quantities below are the correct amount to complete the assembly. In some cases more fittings may be supplied than are required.

<p>A  Metal dowel (F901) x 14</p>	<p>B  Large locking nut (F900) x 6</p>	<p>C  Small locking nut (F3) x 8</p>
<p>D  Wooden dowel (F22) x 6</p>	<p>E  Nail (F51) x 20</p>	<p>F  Knock-in Peg (F171GY) x 16</p>
<p>G  40mm Screw (F910) x 8</p>	<p>H  38mm Screw (F81) x 8</p>	<p>I  9mm Screw (F73) x 16</p>
<p>J  9mm Screw (F74) x 8</p>	<p>K  Wedgefix (F639) x 16</p>	<p>L  Handle (F463) x 8</p>
<p>M  Drawer runner (F1004) x 8</p>		<p>N  Foot (F340) x 4</p>
<p>O  Strap  Screw  Washer x 2 Overbalance protector kit (F269) x 1</p>		

Tools required

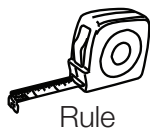

Rule



Scissors



Cross-head screwdriver



Hammer



Eye protection (when using a hammer or drill)



Electric drill (only use when drilling into walls)

Ruler - Use this ruler to help correctly identify the screws



Assembly Instructions

If you have damaged or missing components, call the
Customer Helpline: 08456 400800 quoting the reference
numbers below

Step 1

Prepare the large drawer front

Screw 2 metal dowels **A** into the large drawer front **6**.

Note: Tighten the metal dowels up fully against the panels.

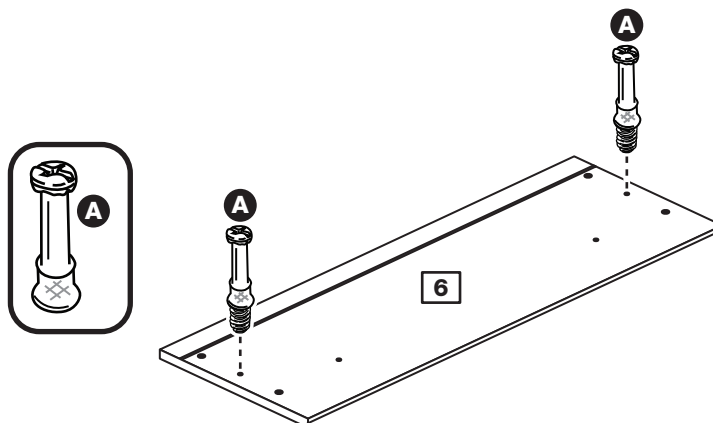

Step 2

Prepare the pair of large drawer sides

Insert a small locking nut **C** into the hole shown on the large left drawer side **8** and the large right drawer side **9**.

Note: The arrow on the locking nut **must** point towards the hole in the edge of the panel.

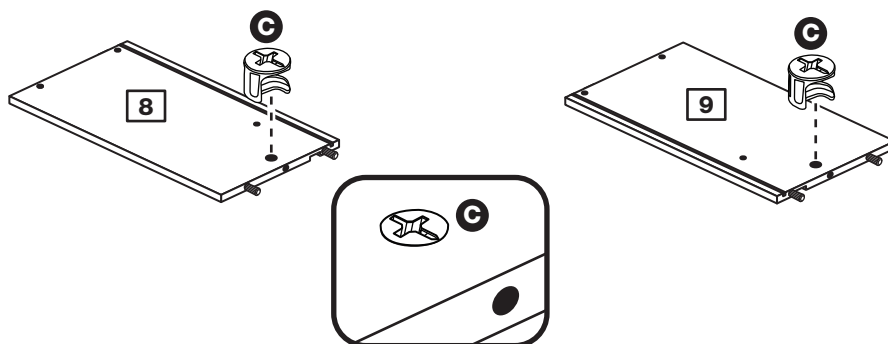

Step 3

Attach the large drawer sides to the large drawer front

Push the large left drawer side **8** and large right drawer side **9** onto the back of the large drawer front **6**.

Turn the small locking nuts **C** on the large left drawer side **8** and large right drawer side **9**.

Note: Turn the locking nuts **C** clockwise to secure panels - more than 1/2 a turn.

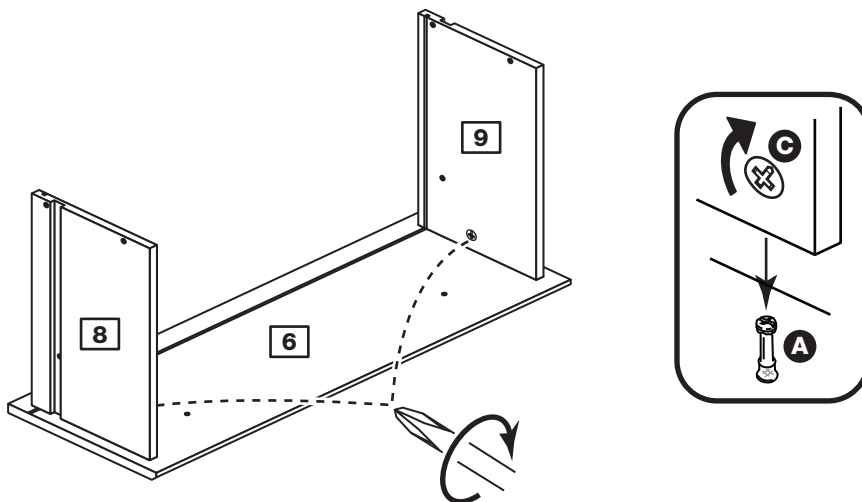

Assembly Instructions

Step 4

Fit the drawer base

Slide the drawer base **14** down the grooves in the large drawer sides **8** and **9** and down into the groove in the large drawer front **6**.

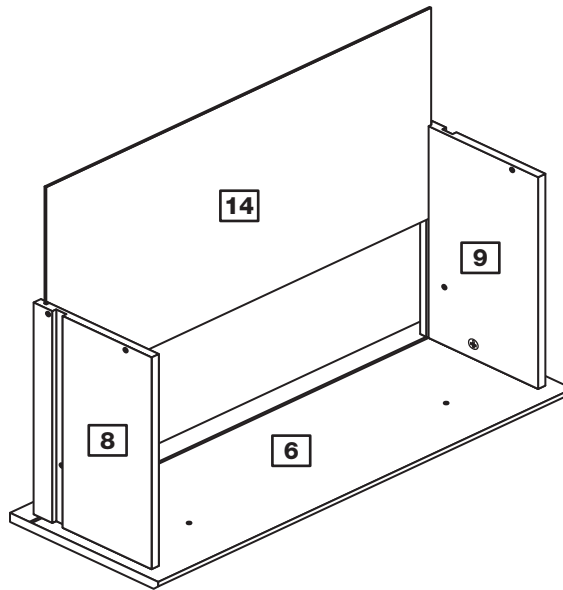

Step 5

Fit the large drawer back

Fit the large drawer back **10** between the large drawer sides **8** and **9**. Make sure that the drawer base **14** fits into the groove in the large drawer back **10**.

Hold the large drawer back **10** in position and tap the knock-in pegs **F** through the holes in the large drawer sides **8** and **9**.

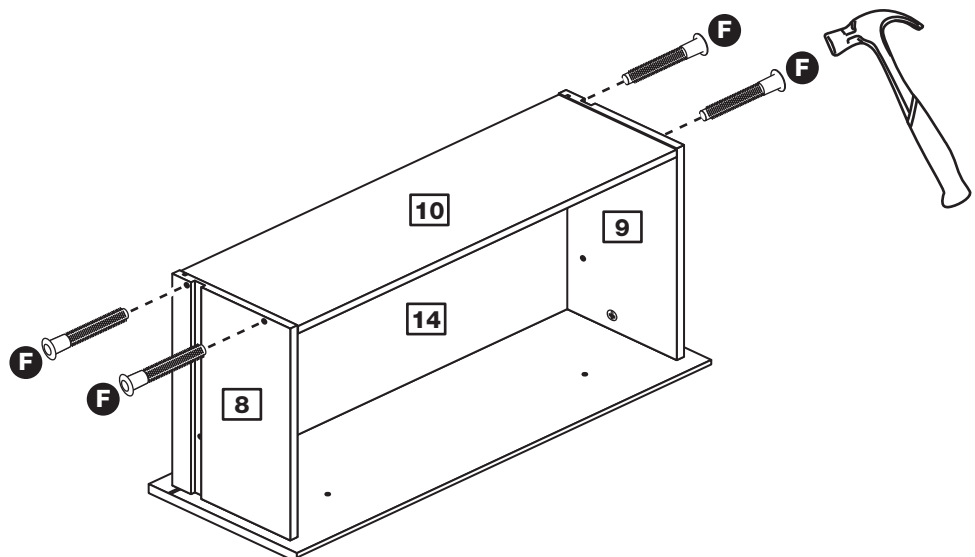

Step 6

Attach the handles

Attach 2 handles **L** to the large drawer front **6** using screw **H**.

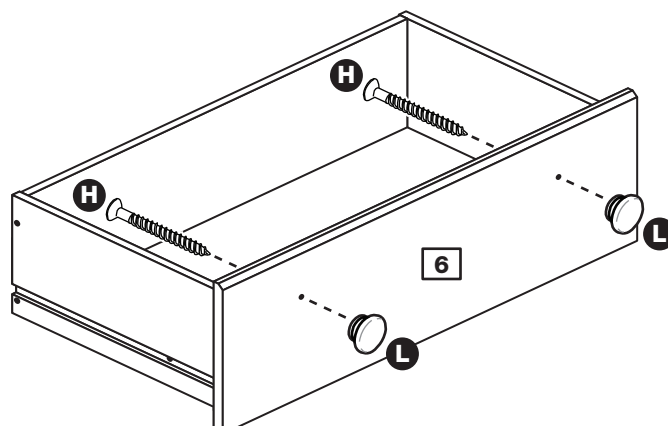

Assembly Instructions

Step 7

Fit the wedgexes

Turn the large drawer assembly over and slide 4 wedgexes **K** into the front and back grooves, as shown, and tighten up the screws.

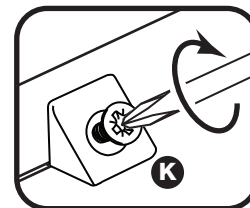
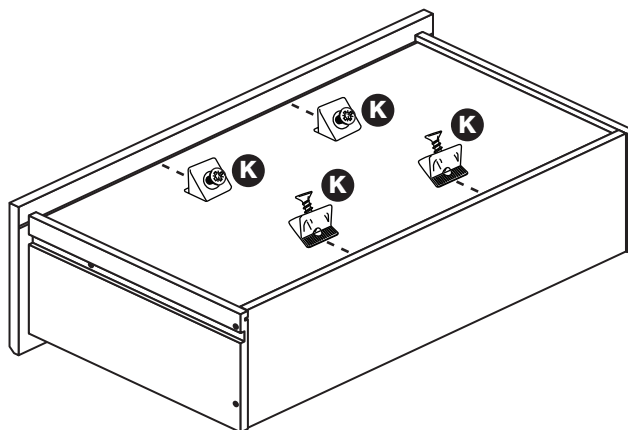

Step 8

Prepare the 3 small drawer fronts

Screw 2 metal dowels **A** into each small drawer front **7**.

Note: Tighten the metal dowels up fully against the panels.

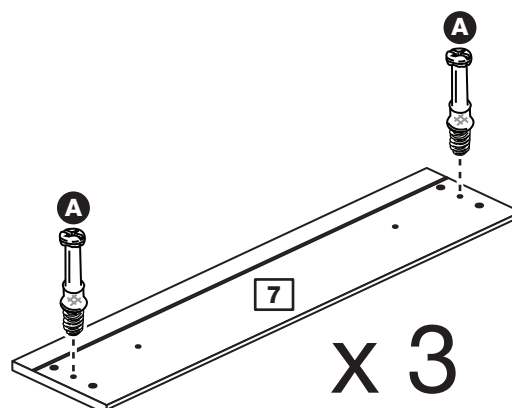
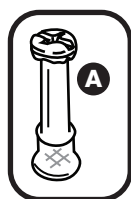

Step 9

Prepare the 3 pairs of small drawer sides

Insert a small locking nut **C** into the hole shown on the small left drawer side **11** and the small right drawer side **12**.

Note: The arrow on the locking nut **must** point towards the hole in the edge of the panel.

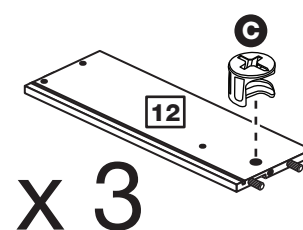
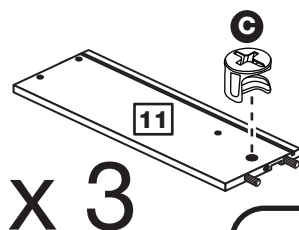

Assembly Instructions

Step 10

Attach the small drawer sides to the small drawer fronts

Push the small left drawer side **11** and small right drawer side **12** onto the back of the small drawer front **7**.

Turn the small locking nuts **C** on the small left drawer side **11** and small right drawer side **12**.

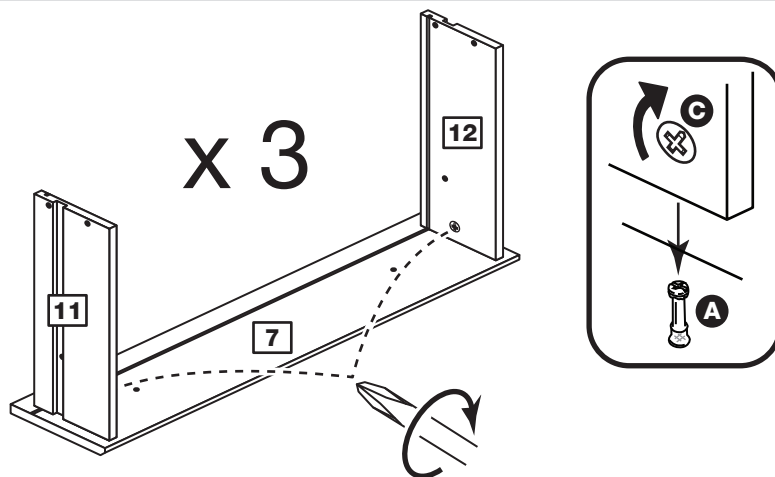

Step 11

Fit the drawer bases

Slide the drawer base **14** down the grooves in the small drawer sides **11** and **12** and down into the groove in the small drawer front **7**.

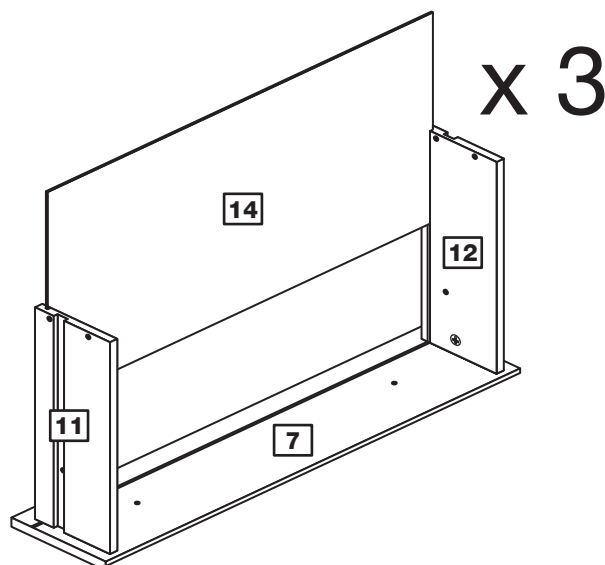

Step 12

Fit the small drawer backs

Fit the small drawer back **13** between the small drawer sides **11** and **12**. Make sure that the small drawer base **14** fits into the groove in the small drawer back **13**.

Hold the small drawer back **13** in position and tap the knock-in pegs **F** through the holes in the small drawer sides **11** and **12**.

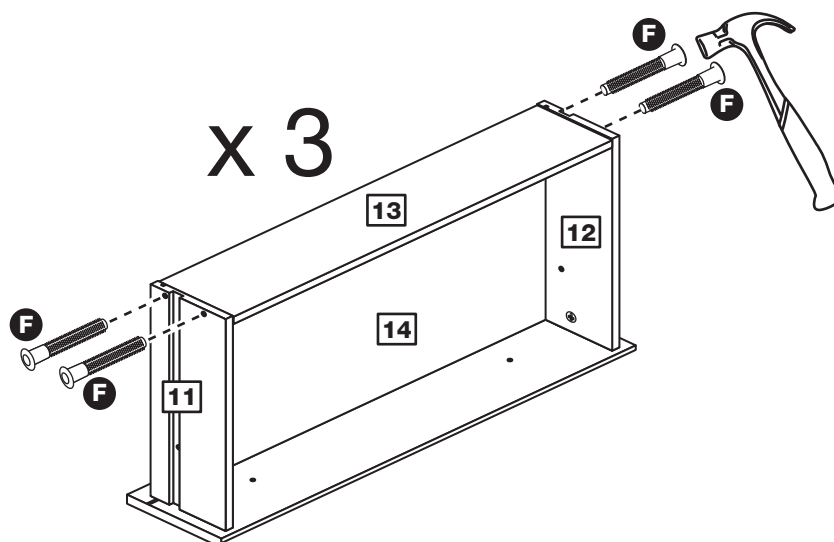

Assembly Instructions

Step 13

Attach the handles

Attach 2 handles **L** to each of the small drawer fronts **7** using screws **H**.

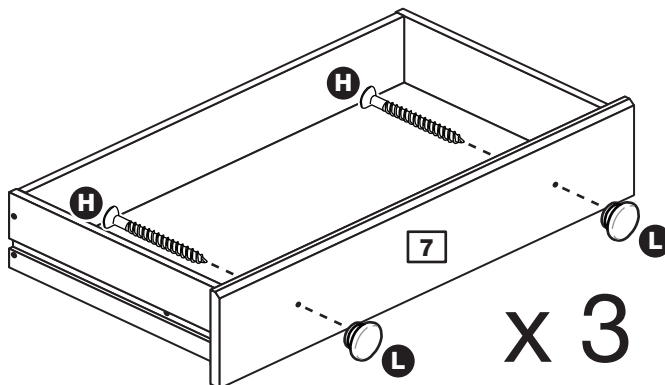

Step 14

Fit the wedgexes

Turn the small drawer assemblies over and slide 4 wedgexes **K** into the front and back grooves, as shown, and tighten up the screws.

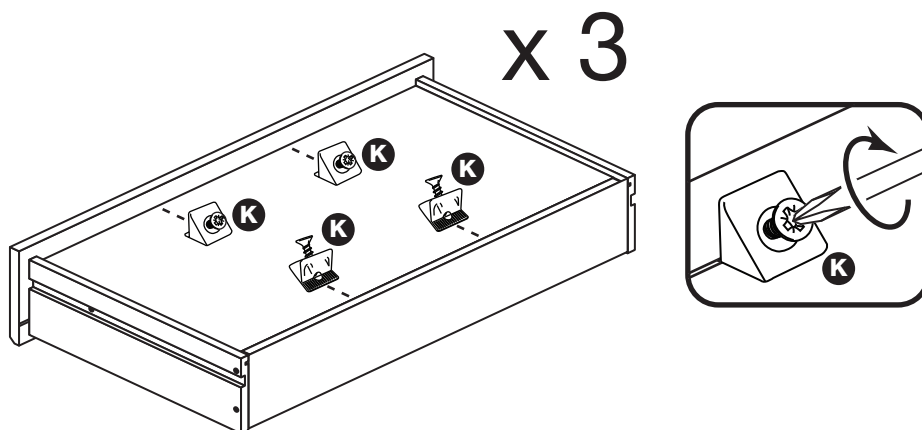

Step 15

Prepare the top

Screw 4 metal dowels **A** into the top **3**.

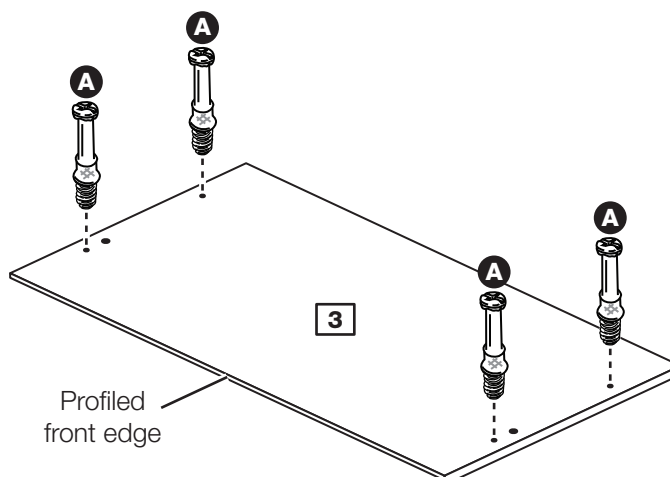

Assembly Instructions

Step 16

Prepare the left side

a: Place 4 runners **M** on the left side **1**. Slide back the top of runner and use the 2nd hole from the front to fit the 1st screw **I**.

b: Slide the runner **M** back the other way and fit the 2nd screw **I** into the corresponding hole in the left side **1**.

c: Screw a metal dowel **A** into the left side **1**.

Insert 2 large locking nuts **B** into the left side **1**.

Note: The arrow on the locking nut **must** point towards the hole in the edge of the panel.

Tap 2 wooden dowels **D** into the left side **1**.

Note: Wooden dowels **must not** stick out from the edge by more than 10mm or they may damage other panels.

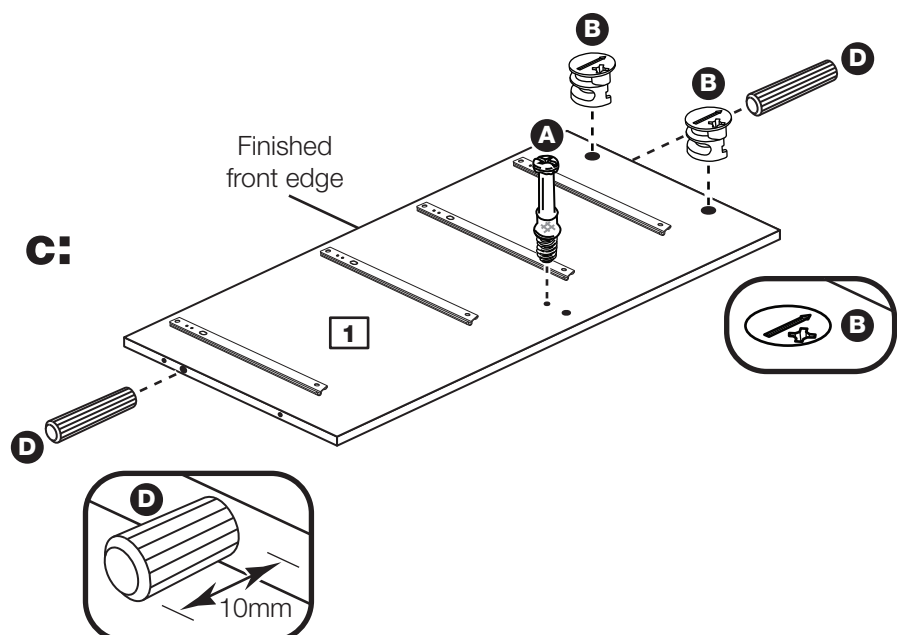
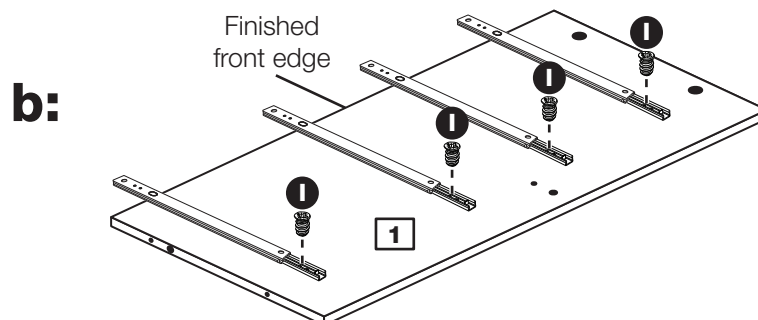
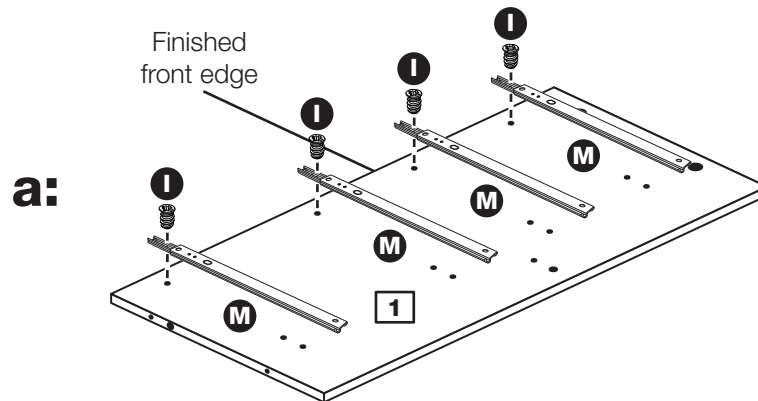
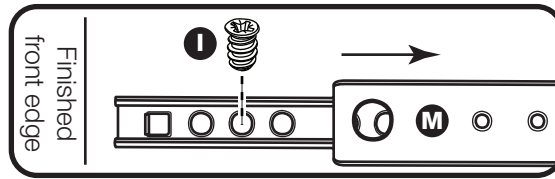

Assembly Instructions

Step 17

Prepare the right side

a: Place 4 runners **M** on the right side **2**. Slide back the top of runner and use the 2nd hole from the front to fit the 1st screw **I**.

b: Slide the runner **M** back the other way and fit the 2nd screw **I** into the corresponding hole in the right side **2**.

c: Screw a metal dowel **A** into the right side **2**.

Insert 2 large locking nuts **B** into the right side **2**.

Tap 2 wooden dowels **D** into the right side **2**.

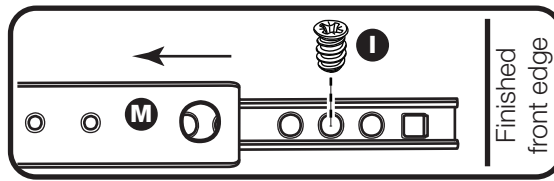

a:

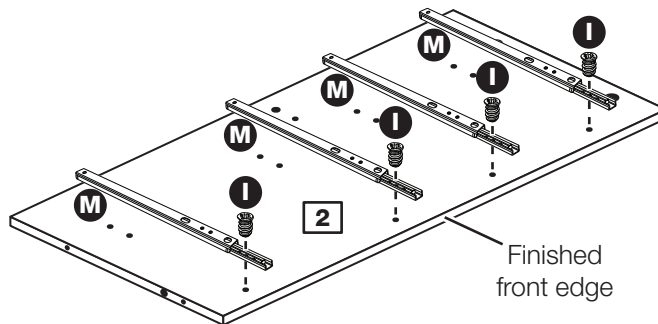

b:

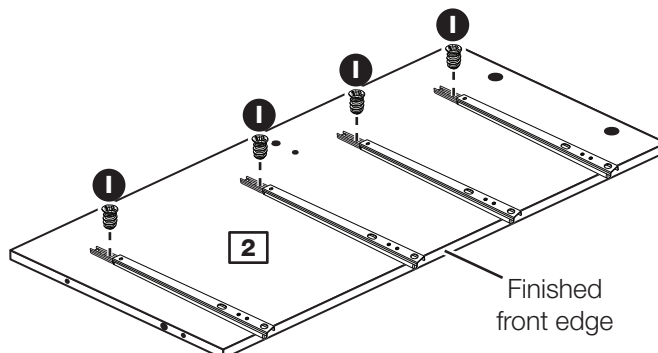

c:

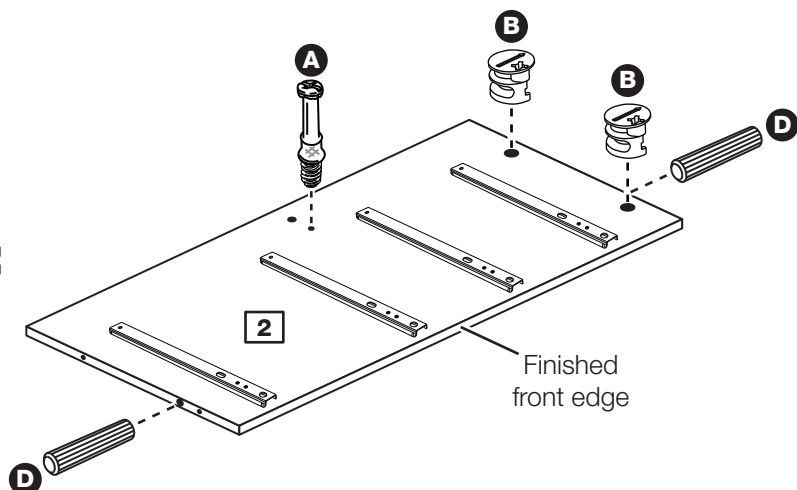

Assembly Instructions

Step 18

Join the top and right side

Push the right side **2** onto the top **3**.

Use a screwdriver to tighten the 2 large locking nuts **B** fitted to the right side **2**.

Note: Turn the large locking nuts **B** as far as they will go - more than 1/2 a turn.

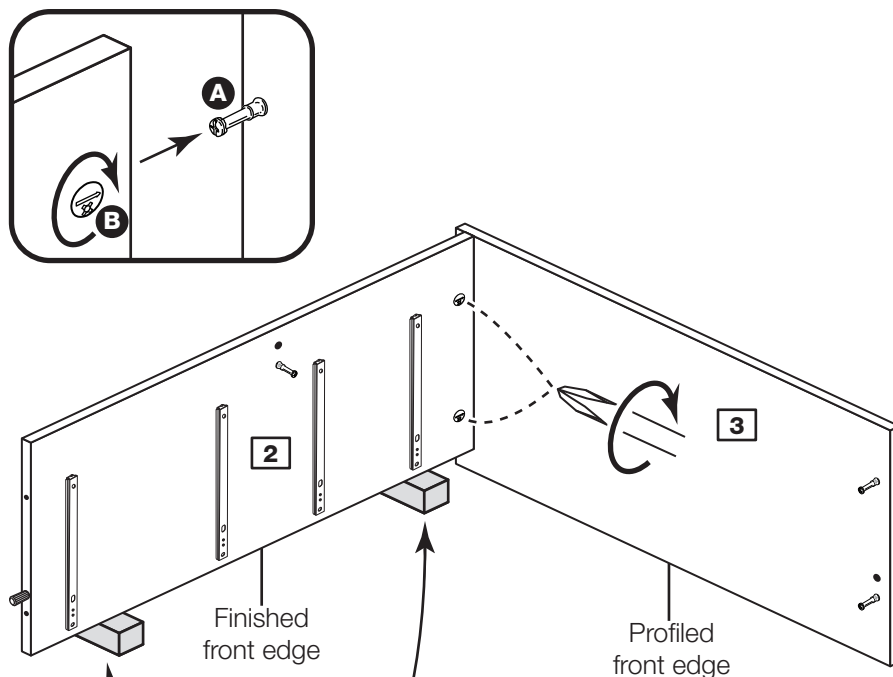

Note: To make it easier to fit the top and base panels, place polystyrene blocks from the packaging underneath the side panels to raise the assembly.

Step 19

Prepare the back rail

Insert 2 large locking nuts **B** into the back rail **5**.

Tap 2 wooden dowels **D** into the back rail **5**.

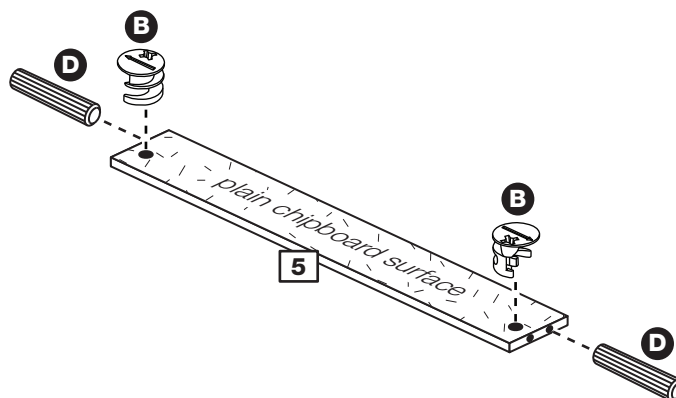

Assembly Instructions

Step 20

Fit the back rail

Push the back rail **5** onto the right side **2**.

Use a screwdriver to tighten the large locking nut **B** fitted to the back rail **5**.

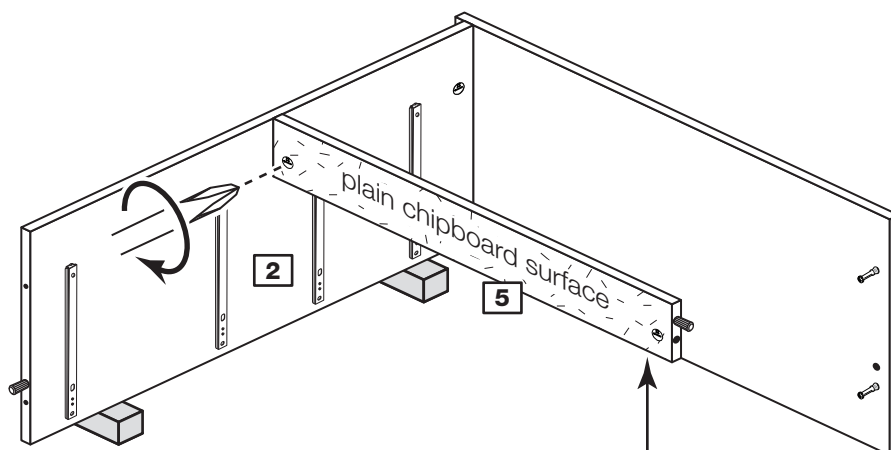

Note: Support the back rail until the left side has been fitted in the next step.

Step 21

Fit the left side

Push the left side **1** onto the top **3** and back rail **5**.

Use a screwdriver to tighten the 3 large locking nuts **B** fitted to the left side **1** and back rail **5**.

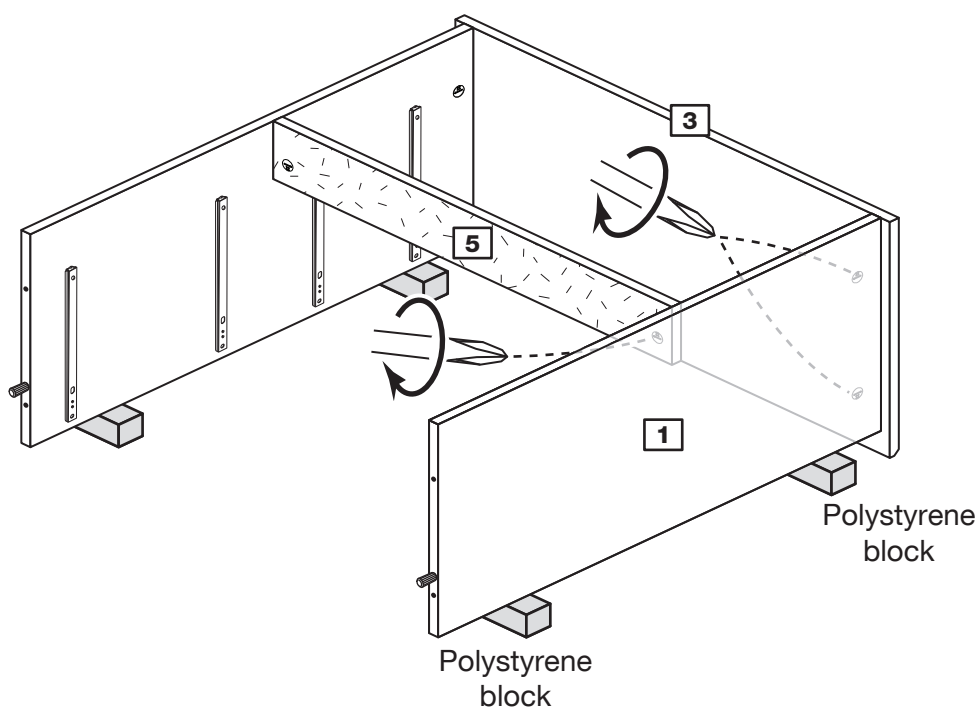

Assembly Instructions

Step 22

Fit the base

Attach the base **4** to the left side **1** and right side **2** using 4 screws **G**.

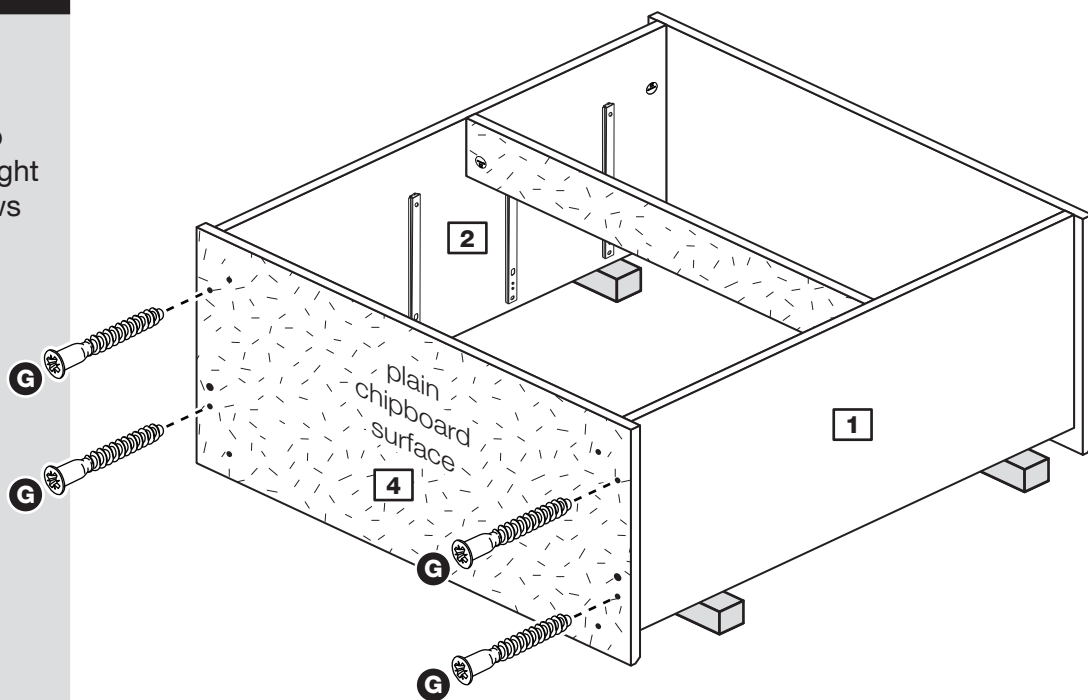

Step 23

Fit the feet

Fit the 4 feet **N** to the base **4** using screws **G** and tighten them.

Note: You may find it easier to turn the foot as the screw is held with the screwdriver.

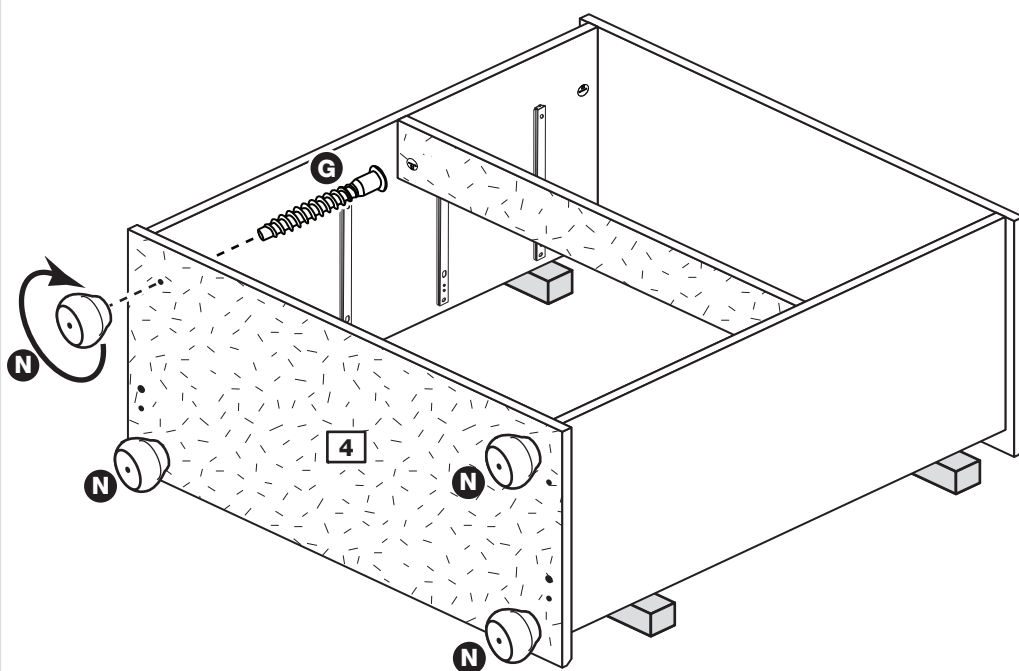

Assembly Instructions

Step 24

Fit the back

a: Square up the unit by making sure that measurement **x to x** equals **y to y**.

b: Place the back **15** onto the unit.

Nail **E** around the outside edges of the back **15**.

Note: Nails should be spaced out evenly.

Stand the unit up for the next step.



Warning: The unit is heavy. Lift with care.

a: The measurement from top corner X to bottom corner X must be equal to the measurement from top corner Y to bottom corner Y

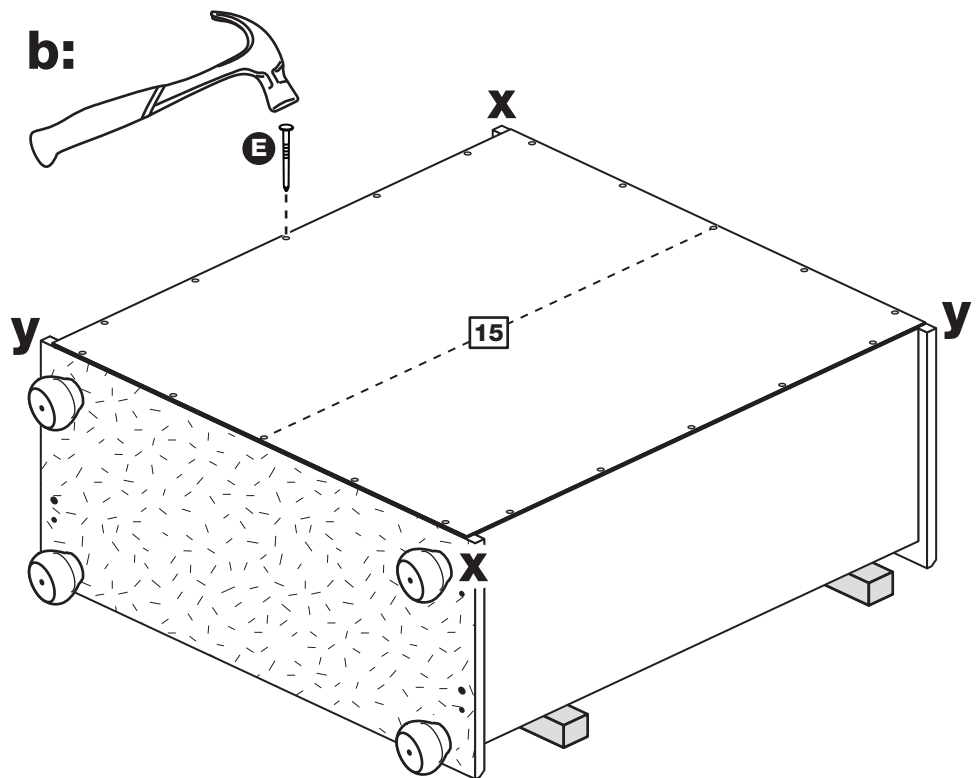

Step 25

Fit the overbalance protector

To prevent possible overbalancing we recommend that this unit is secured to a suitable wall by use of the overbalance protector kit **⊙** fitted as shown or an alternative fixing method of your choice.

Wall fixings are not supplied as they will need to suit the wall type.

Fit one end of the strap to the wall

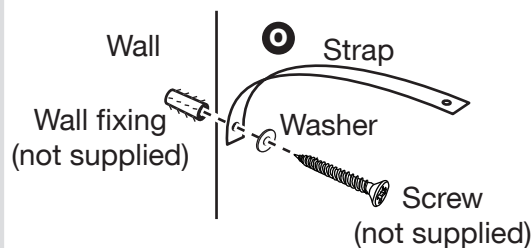

Fit the other end of the strap to a suitable position on the unit

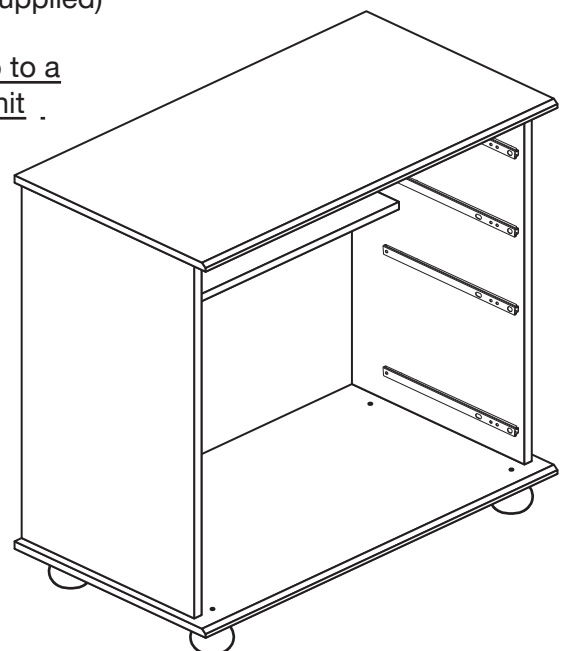
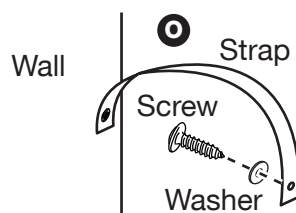

Warning: Take care when drilling the wall that you do not drill into any pipes, wires etc. If in doubt, consult an expert

Assembly Instructions

Step 26

Fit the drawers

Starting with the large bottom drawer, slide both the runners **M** forward and locate the drawer sides between them, lining up the holes in the drawer wrap with the 2nd 'threaded' holes in the runners **M**.

Working from the inside of the drawer, insert 2 screws **J** through the drawer sides and out into the 2nd threaded hole in the runner.

Note: Do not overtighten the screws **J**. If they catch on the runner you may need to loosen them slightly.

Assembly is complete

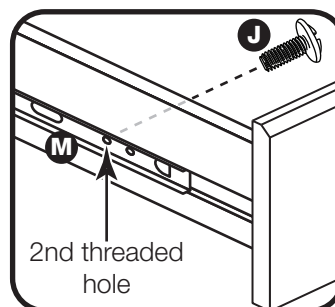
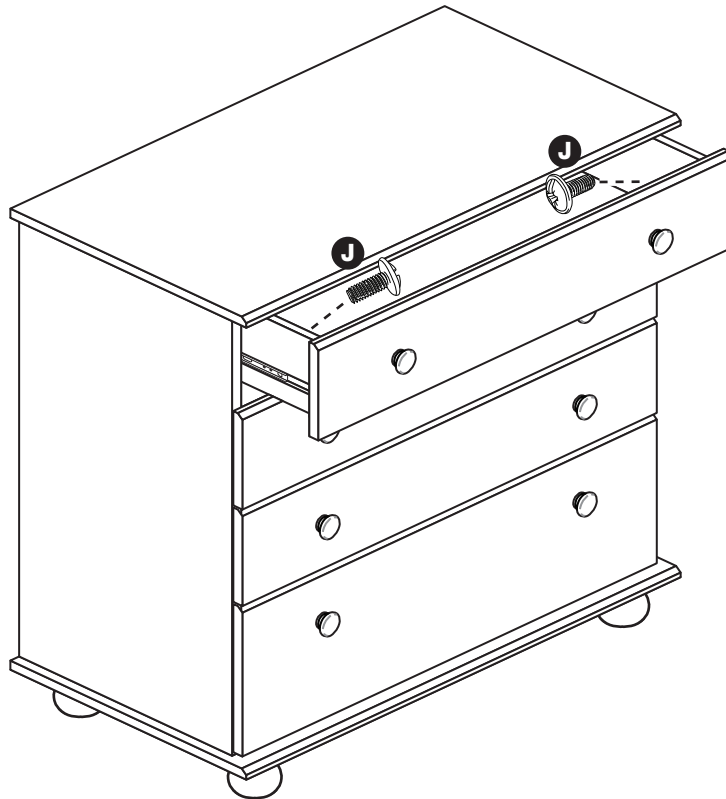

If you need help or have damaged or missing parts, call the Customer Helpline: 08456 400800 and quote the reference numbers on the component pages.

Argos Ltd, 489-499 Avebury Boulevard, Central Milton Keynes, MK9 2NW