

Capella - Dressing Table

Assembly Instructions - Please keep for future reference

262/1982

267/6511

264/0877

227/5091

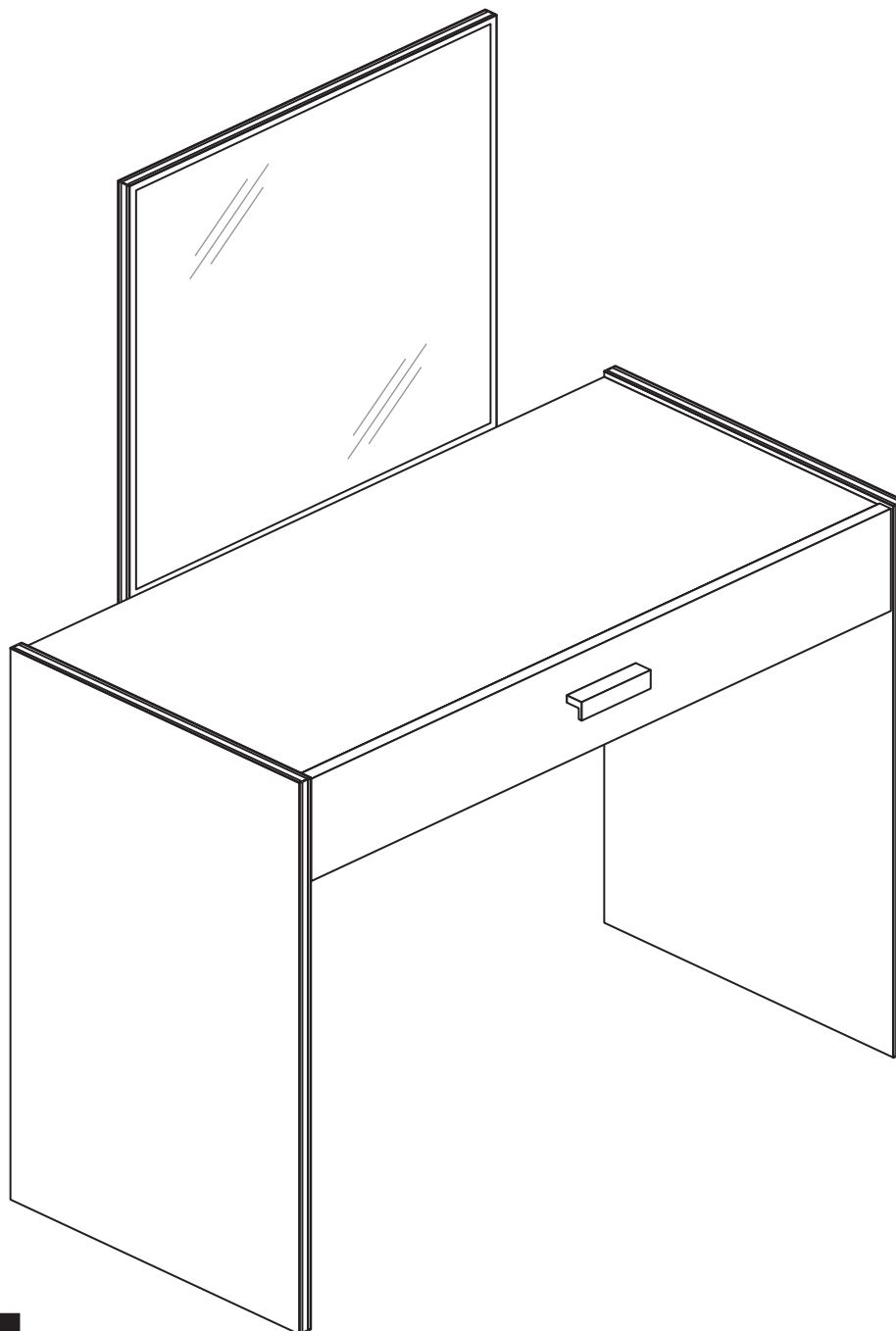

Dimensions

Width - 81.6cm

Depth - 39cm

Height - 129.3cm



**MADE IN
BRITAIN**

Important - Please read these instructions fully before starting assembly

If you need help or have damaged or missing parts, call the **Customer Helpline: 08456 400800**



Safety and Care Advice

Important - Please read these instructions fully before starting assembly

- **Warning:** This unit weighs approximately 23kgs. Please lift with care.

- Check you have all the components and tools listed on pages 2 and 3.

- Remove all fittings from the plastic bags and separate them into their groups.

- Keep children and animals away from the work area, small parts could choke if swallowed.

- Parts of the assembly will be easier with 2 people.

- Make sure you have enough space to layout the parts before starting.

- Do not stand or put weight on the product, this could cause damage.

- Assemble the item as close to its final position (in the same room) as possible.

- Assemble on a soft level surface to avoid damaging the unit or your floor (use opened out unit carton).



- We do not recommend the use of power drill/drivers **for inserting screws**, as this could damage the unit. Only use hand screwdrivers.

- **Safety note:** If there is any chance of this unit being pulled over by children etc. it is recommended that the unit is secured to a wall using suitable fixings (not supplied).

- Dispose of all packaging carefully and responsibly.

Care and maintenance

- Only clean using a damp cloth and mild detergent, do not use bleach or abrasive cleaners.

- From time to time check that there are no loose screws on this unit.

- This product should not be discarded with household waste. Take to your local authority waste disposal centre.

Note: If required the next page can be cut out and used as reference throughout the assembly. Keep this page with these instructions for future reference.

Components - Panels

If you have damaged or missing components, call the **Customer Helpline: 08456 400800** quoting the reference numbers below

Please check you have all the panels listed below

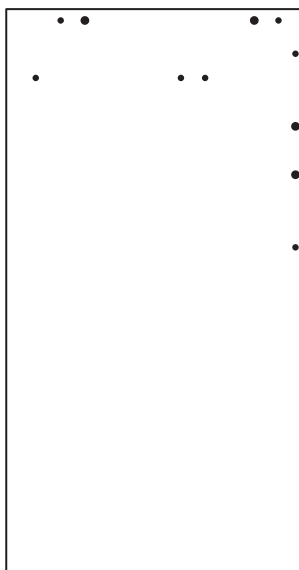

1 Left Side (D1033A)
(744 x 390mm)

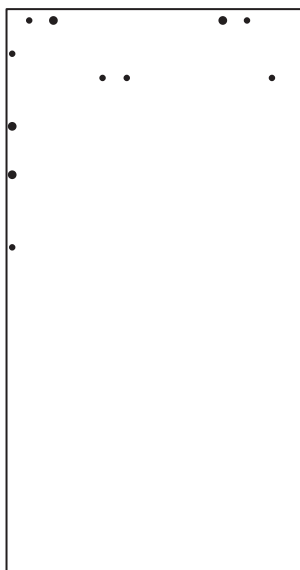

2 Right Side (D1034A)
(744 x 390mm)

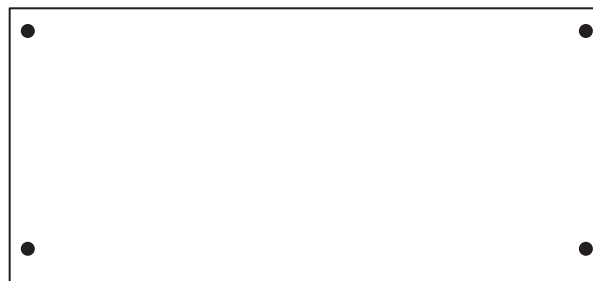

3 Top (D1035A)
(786 x 369mm)

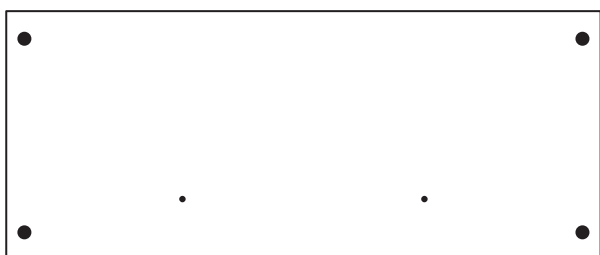

4 Modesty (D1037A)
(786 x 329mm)

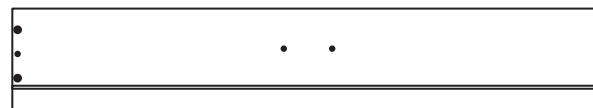

5 Drawer Front (D1038A)
(782 x 138mm)

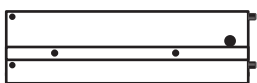

6 Left Drawer Side (W516BLH)
(320 x 95mm)

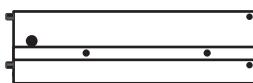

7 Right Drawer Side (W516BRH)
(320 x 95mm)

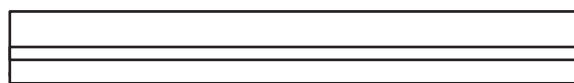

8 Drawer Back (W441BBK)
(756 x 95mm)



9 Drawer Base (T441)
(767 x 317mm)

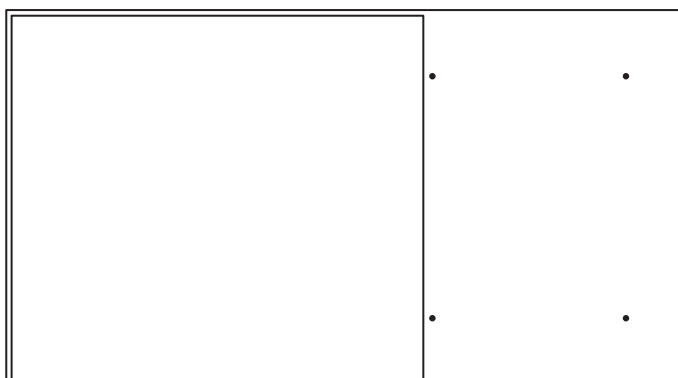

10 Mirror Back (D1036A)
(900 x 495mm)

(Mirror SG12
484 x 548mm
4mm Safety Back SAR)









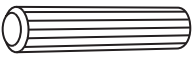
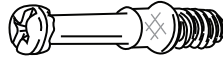
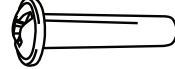

Components - Fittings

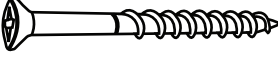
If you have damaged or missing components, call the **Customer Helpline: 08456 400800** quoting the reference numbers below

Please check you have all the fittings listed below

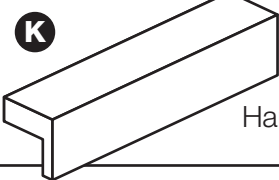
Note: The quantities below are the correct amount to complete the assembly. In some cases more fittings may be supplied than are required.

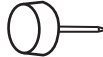
<p>A </p> <p>Wooden dowel (F22) x 8</p>	<p>B </p> <p>Metal dowel (F901) x 10</p>	<p>C </p> <p>25mm Connecting sleeve (F432) x 2</p>
<p>D </p> <p>Large locking nut (F900) x 8</p>	<p>E </p> <p>Small locking nut (F3) x 2</p>	<p>F </p> <p>45mm Screw (F65) x 2</p>
<p>G </p> <p>25mm Screw (F50) x 2</p>	<p>H </p> <p>9mm Screw (F74) x 4</p>	<p>I </p> <p>9mm Screw (F73) x 4</p>
<p>J </p> <p>Drawer runner (F1004) x 2</p>		<p>K </p> <p>Handle (F930) x 1</p>
<p>L </p> <p>Knock-in Peg (F171) x 4</p>	<p>M </p> <p>Wedgefix (F639) x 4</p>	<p>N </p> <p>Plastic Nail (F91) x 4</p>

Tools required

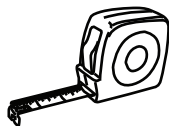

Rule



Cross-head screwdriver



Scissors



Hammer



Eye protection (when using a hammer or drill)

Ruler - Use this ruler to help correctly identify the screws

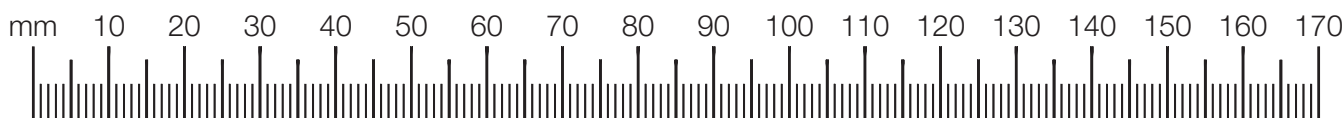

Assembly Instructions

If you have damaged or missing components, call the Customer Helpline: 08456 400800 quoting the reference numbers below

Step 1

Prepare the drawer front

Screw 2 metal dowels **B** into the holes shown on the back of the drawer front **5**.

Note: Tighten the metal dowels up fully against the panels.

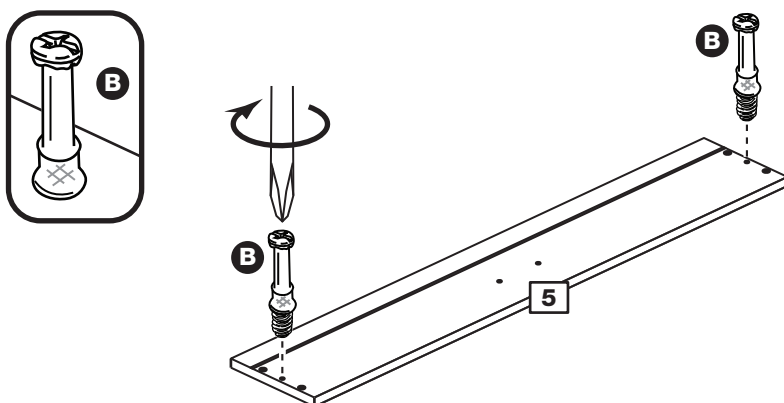

Step 2

Prepare the drawer sides

Insert a small locking nut **E** into the hole shown on the left drawer side **6** and right drawer side **7**.

Note: The arrow on the locking nut **must** point towards the hole in the edge of the panel.

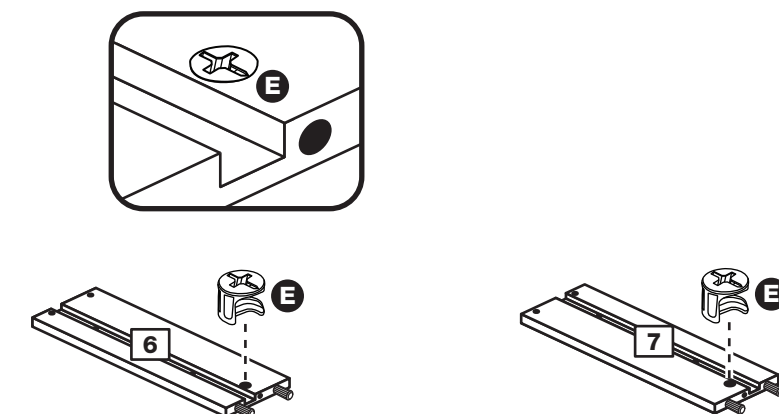

Step 3

Assemble the drawer sides and back

Fit the left drawer side **6** and right drawer side **7** to the drawer back **8** by tapping in 4 knock-in pegs **L**.

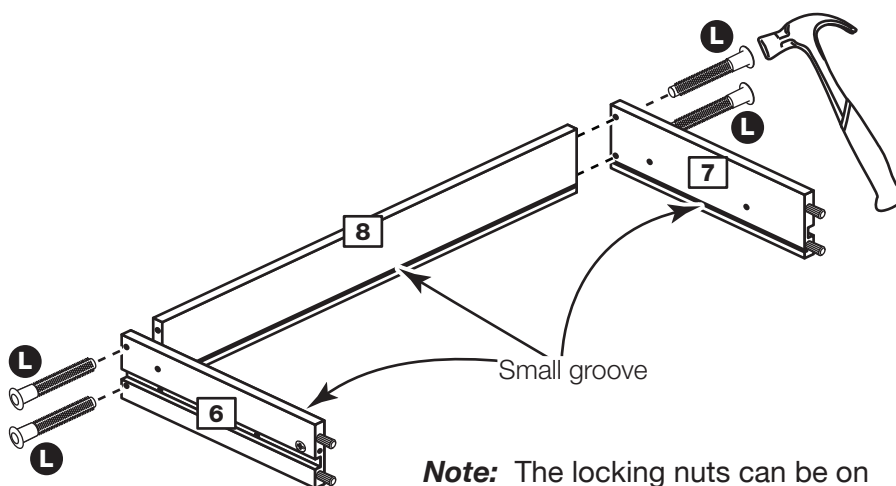

Note: The locking nuts can be on either surface of the drawer sides. Make sure that the small groove is on the inside, as shown.

Assembly Instructions

Step 4

Fit the drawer base

Slide the drawer base **9** along the grooves of the drawer sides **6** and **7** into the groove of the drawer back **8**.

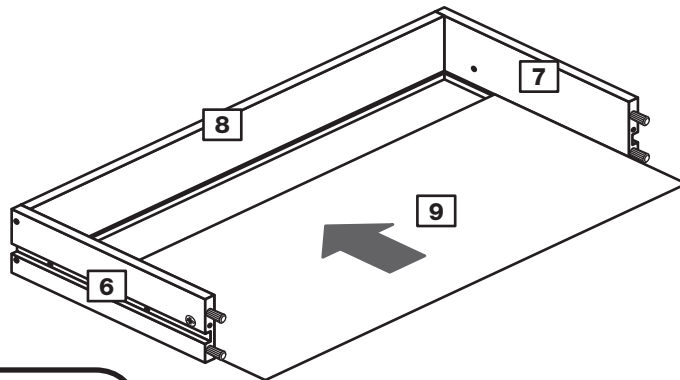

Step 5

Attach the drawer front

Turn the drawer assembly over and push onto the back of the drawer front **5**.

Note: Turn locking nuts **E** clockwise to secure panels - more than 1/2 a turn.

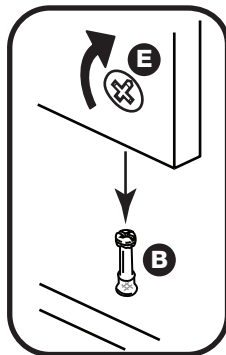

Note: The locking nuts can be on either surface of the drawer sides.

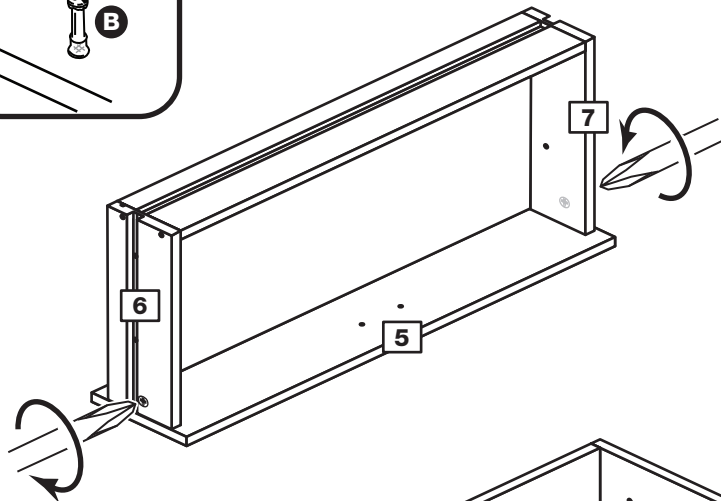

Step 6

Attach the handle

Attach a handle **K** to the drawer front **5** using 2 screws **G**.

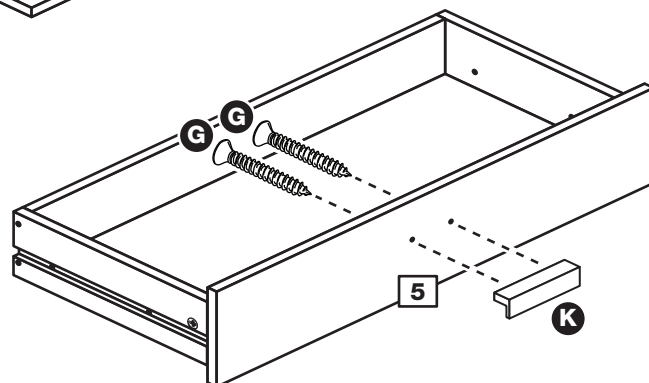

Step 7

Fit the wedgifixes

Turn the drawer assembly over and slide 4 wedgifixes **M** into the front and back grooves, as shown, and tighten up the screws.

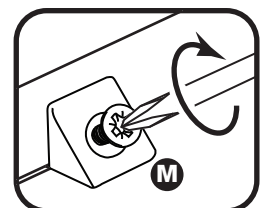
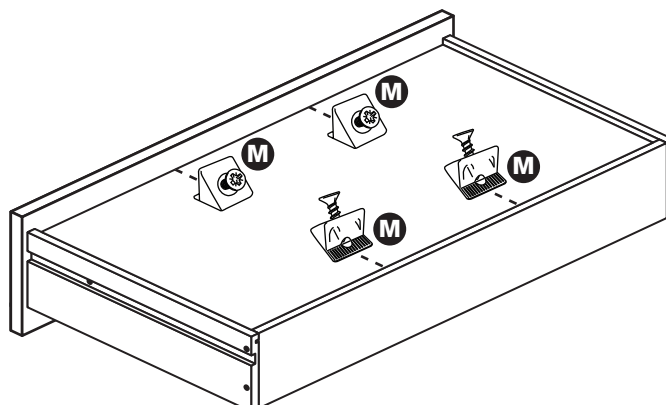

Assembly Instructions

Step 8

Prepare the left side

a: Place 1 runner **J** on the left side **1**. Slide back the top of the runner and use the 1st hole from the front to fit the 1st screw **I**.

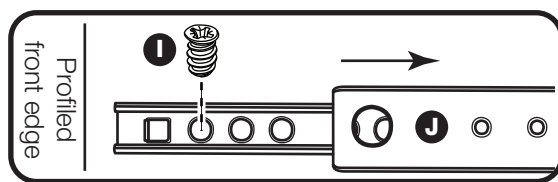

a:

Profiled front edge

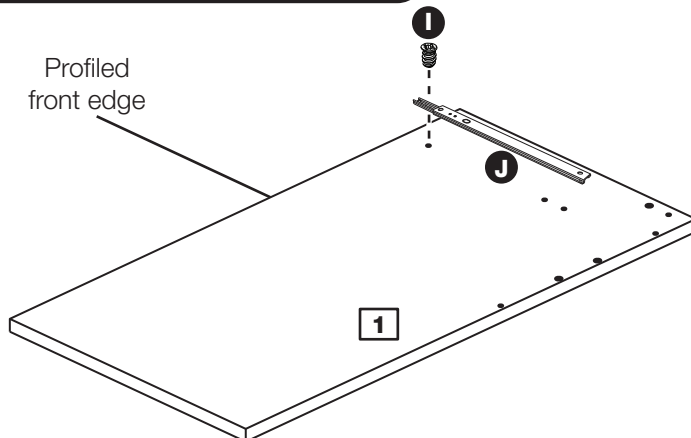

b: Slide the runner back the other way and use the 3rd hole from the back to fit the 2nd screw **I**.

b:

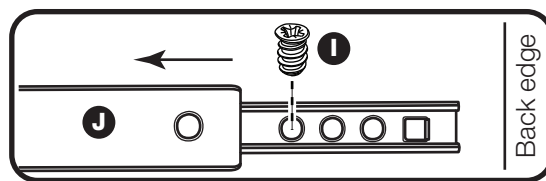

Profiled front edge

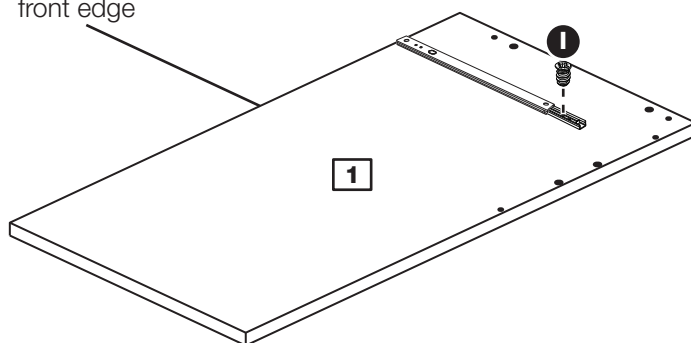

c: Screw 4 metal dowels **B** into the left side **1**.

c:

Profiled front edge

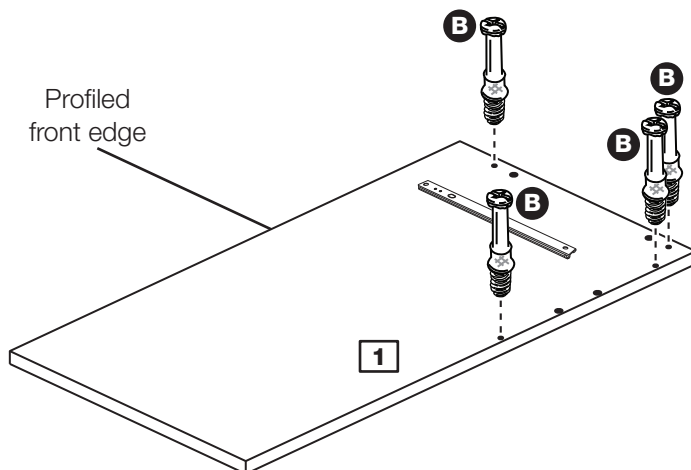

Assembly Instructions

Step 9

Prepare the right side

a: Place 1 runner **J** on the right side **2**. Slide back the top of the runner and use the 1st hole from the front to fit the 1st screw **I**.

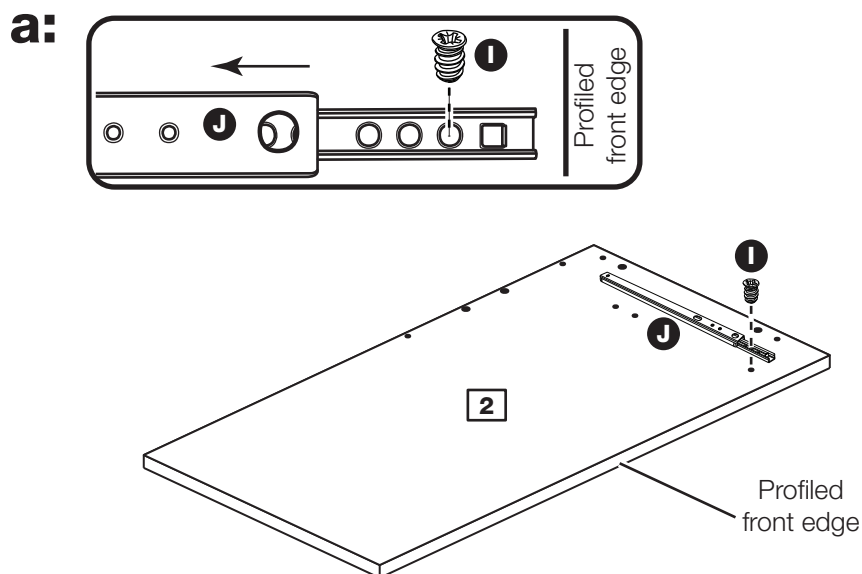

b: Slide the runner back the other way and use the 3rd hole from the back to fit the 2nd screw **I**.

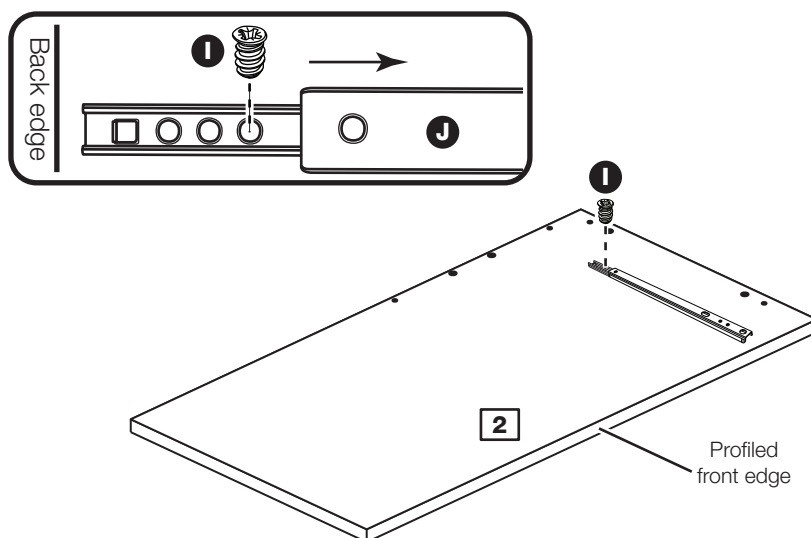

c: Screw 4 metal dowels **B** into the right side **2**.

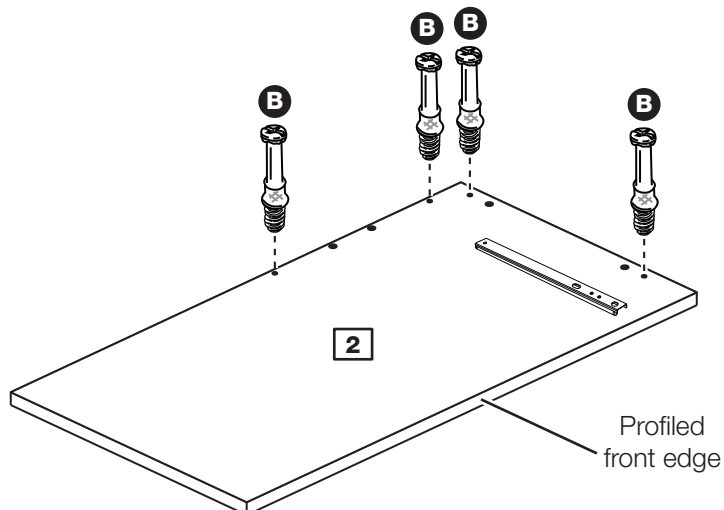

Assembly Instructions

Step 10

Prepare the top

Tap 4 wooden dowels **A** into the top **3** as shown.

Note: Wooden dowels **must not** stick out from the edge by more than 10mm or they may damage other panels.

Insert 4 large locking nuts **D** into the top **3** as shown.

Note: The arrow on the locking nut **must** point towards the hole in the edge of the panel.

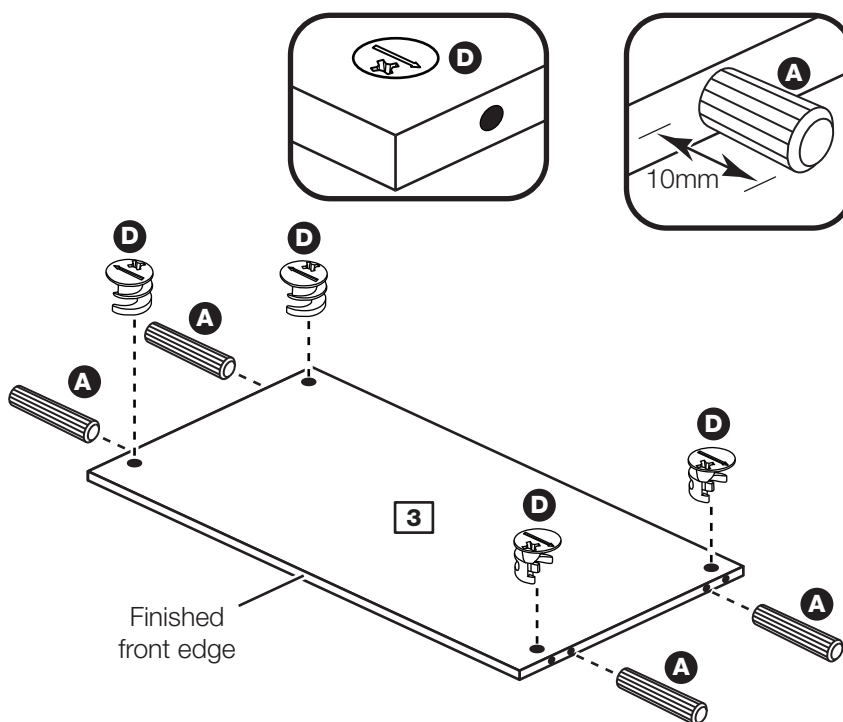

Step 11

Join the right side and top

Push the top **3** onto the right side **2** as shown.

Use a screwdriver to tighten the 2 large locking nuts **D** fitted to the top **3**.

Note: Turn the large locking nuts **D** as far as they will go - more than 1/2 a turn.

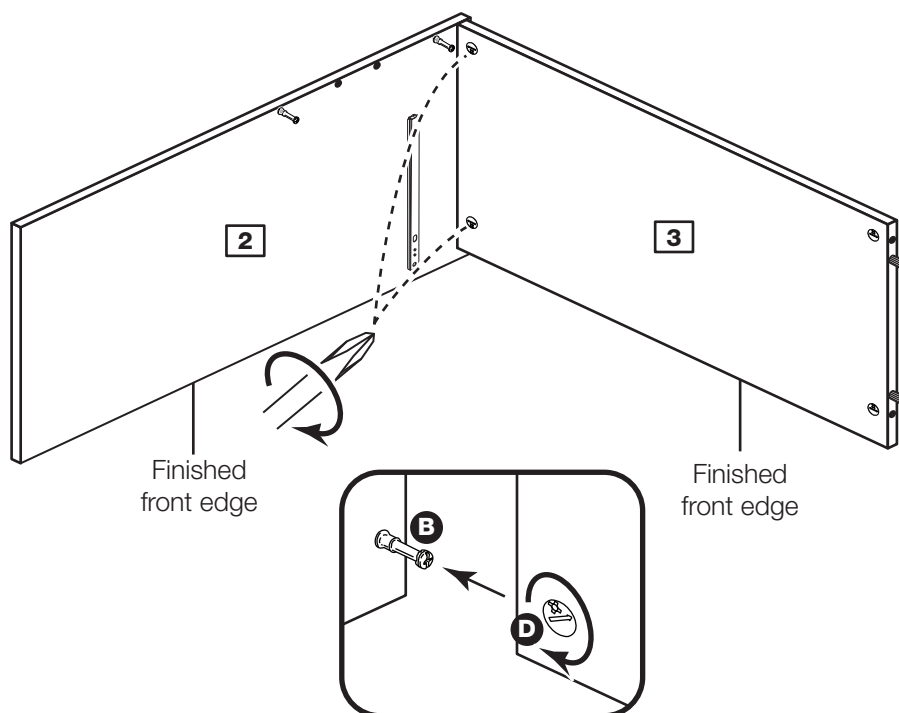

Assembly Instructions

Step 12

Prepare the modesty

Tap 4 wooden dowels **A** into the modesty **4**.

Insert 4 large locking nuts **D** into the modesty **4**.

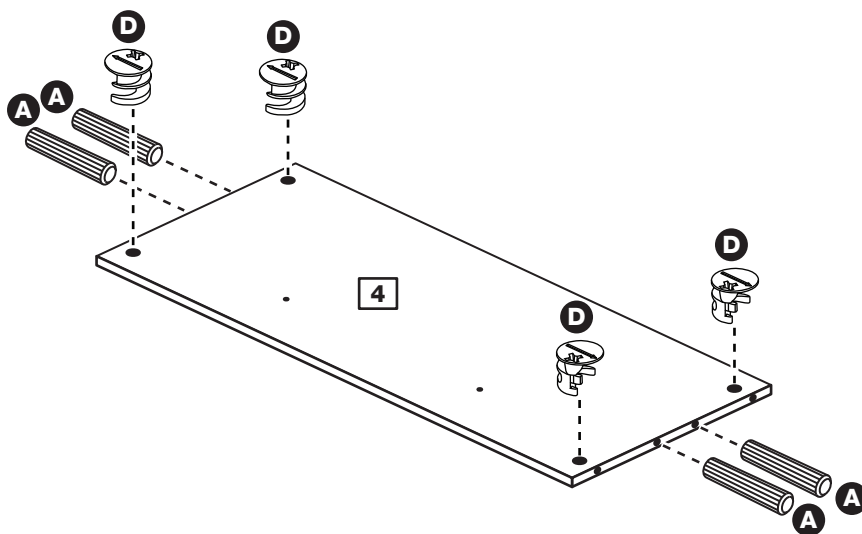

Step 13

Fit the modesty

2 people are needed here

Attach the modesty **4** to the right side **2**.

Use a screwdriver to tighten the 2 large locking nuts **D** fitted to the modesty **4**.

Support the modesty until the left side has been fitted in the next step.

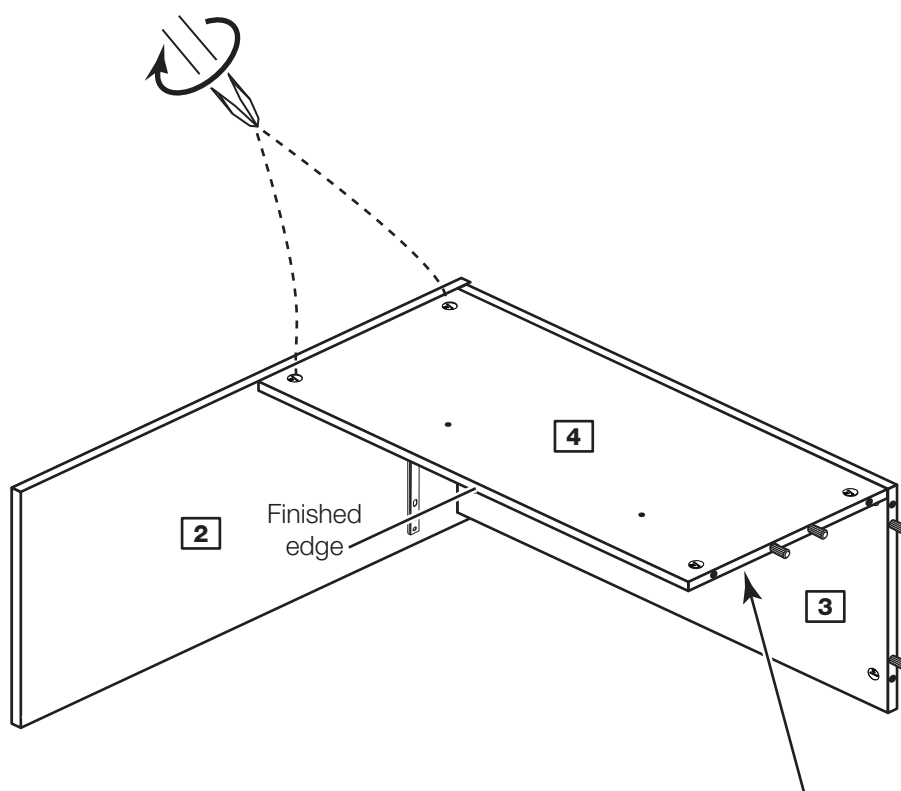

Note: Support this end of modesty until the left side has been fitted in the next step.

Assembly Instructions

Step 14

Fit the left side

Push the left side **1** onto the assembly.

Use a screwdriver to tighten the 4 large locking nuts **D** fitted to the top **3** and the modesty **4**.

Fit the 4 plastic nails

Tap 2 plastic nails **N** into the bottom edge of each of the sides **1** and **2**.

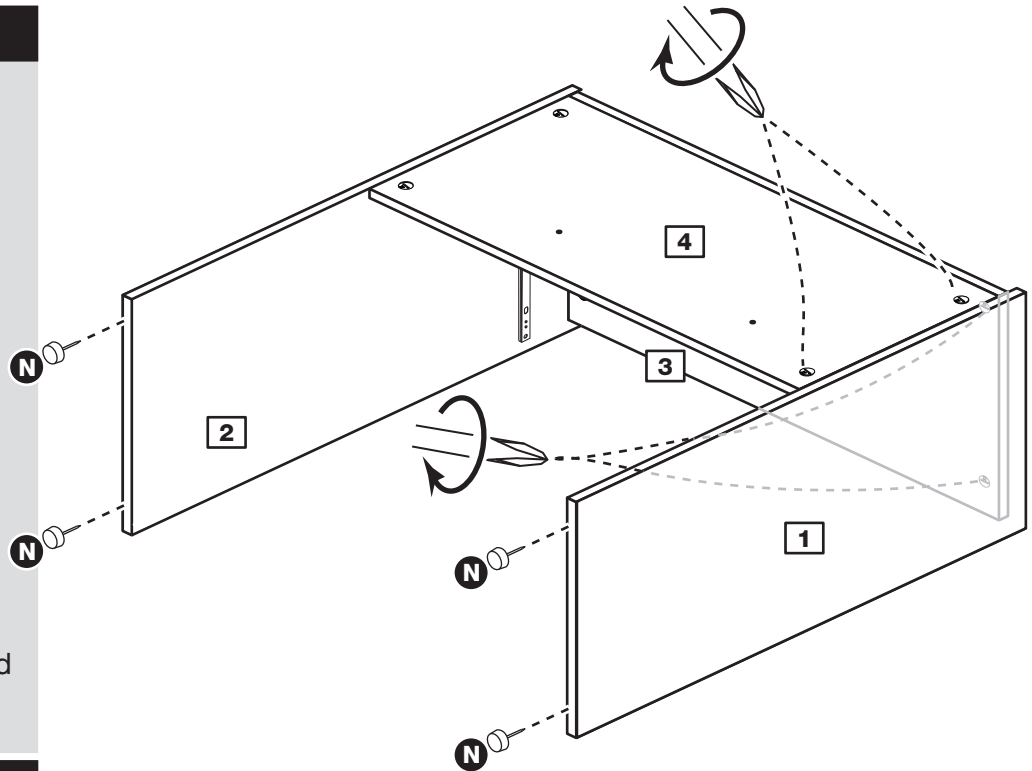

Step 15

Fit the mirror back

2 people will be needed for this stage.

Hold the mirror back **10** in place and fit the 2 connecting sleeves **C** up through the holes in the modesty **4** and into the bottom holes on the mirror back **10**.

Fix using 2 screws **H** through the holes in the mirror back **10** into the connecting sleeves **C**.

Fit 2 screws **F** through the top holes on the mirror back **10** into the edge of the top **3**.

Stand the unit up for the next step.

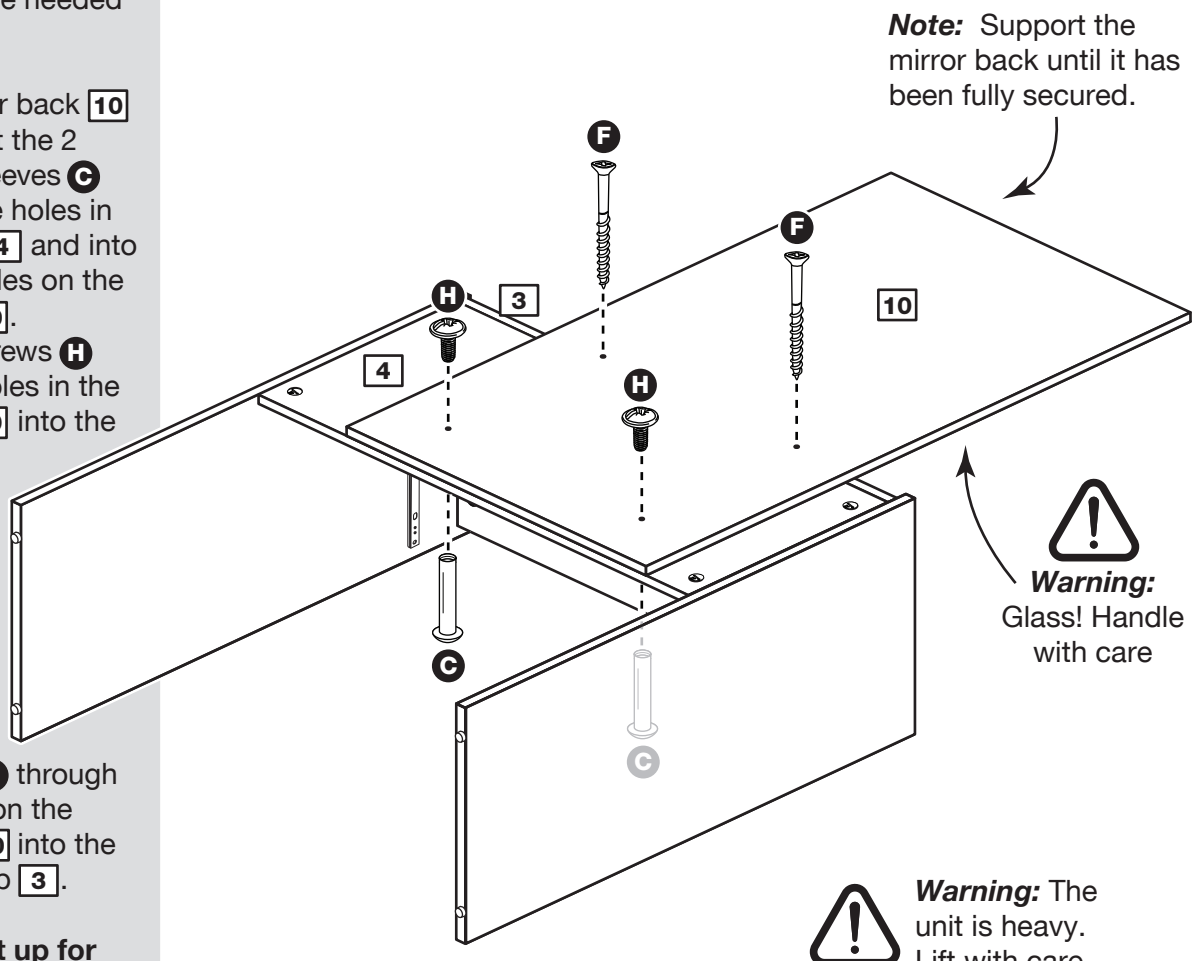

Assembly Instructions

Step 16

Fit the drawer

Slide both the runners **J** forward and locate the drawer sides **6** and **7** between them, lining up the holes in the drawer wrap with the 2nd 'threaded' holes in the runners **J**.

Working from the inside of the drawer, insert 2 screws **H** through the drawer sides and out into the 2nd threaded hole in the runner.

Note: Do not overtighten the screws **H**. If they catch on the runner you may need to loosen them slightly.

Assembly is complete



Warning: The unit is heavy. Lift with care.

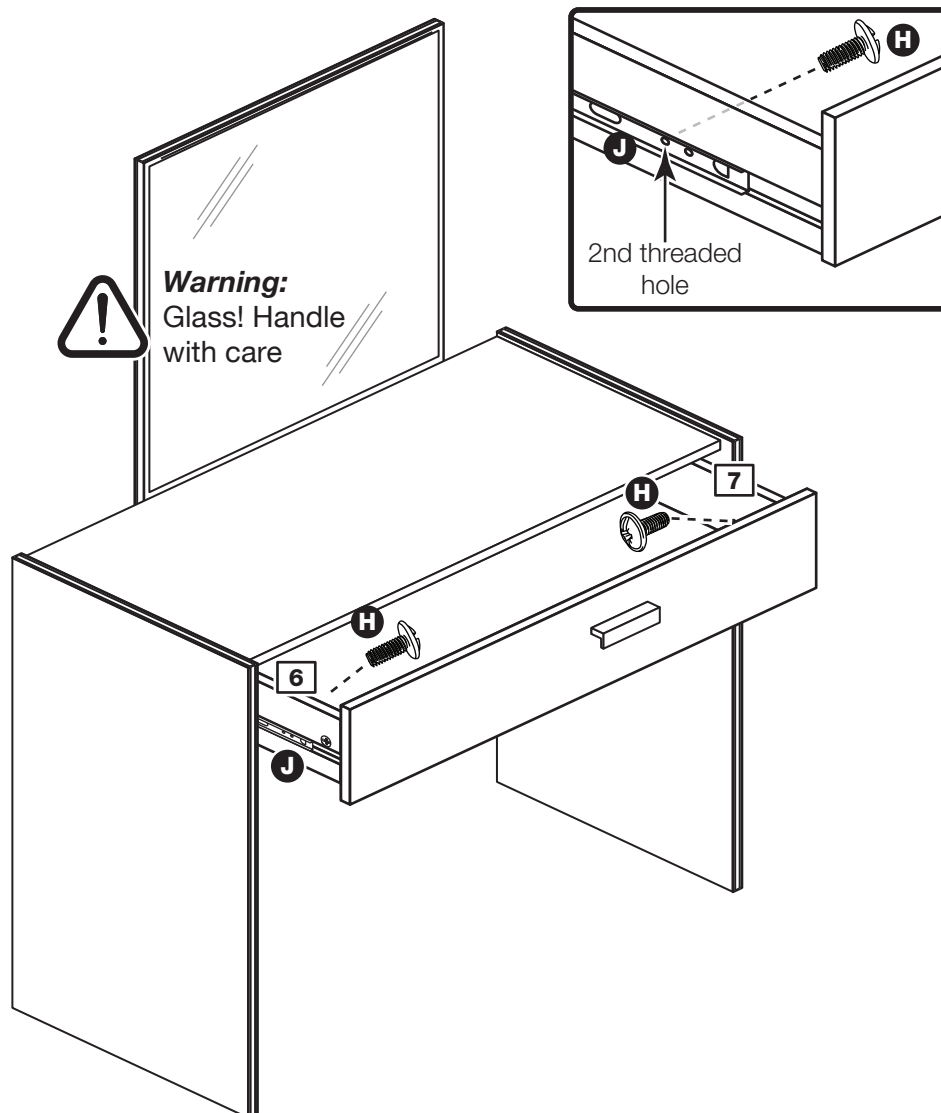

IMPORTANT INFORMATION ABOUT THIS PRODUCT

This product complies with the requirements of BS 7449:1991 and has been manufactured by DECORATIVE PANELS FURNITURE LTD, TEESIDE INDUSTRIAL ESTATE, THORNABY-ON-TEES, CLEVELAND, TS17 9LT.

The product code for this unit and the item code(s) for the glass components are listed in the Assembly Instructions along with a description of the type of glass used. All clear/tinted glass complies with the requirements of BS 6206 Class A. All mirrors comply with the requirements of BS 6206 Class C. If the glass component contained in this unit is chipped or broken consult the furniture manufacturer, retailer, or agent with regard to obtaining a manufacturing specification and shape for replacement glass quoting the unit description and batch number or date of manufacture.

Do not place very hot or very cold items against or in close proximity to glass surface(s) unless adequately thick insulating material is used to prevent such items coming in contact with the glass.

Do not strike the glass with hard or pointed items.

Do not sit or stand upon horizontal glass surfaces.

When cleaning glass panels use a damp cloth or leather with washing up liquid or soft soap if necessary - do not use washing powders or any other substance containing abrasives since these substances scratch glass.

If stated in the instruction leaflet, it is essential that this unit is fixed to a wall.

KEEP THESE INSTRUCTIONS FOR FUTURE USE

If you need help or have damaged or missing parts, call the Customer Helpline: 08456 400800 and quote the reference numbers on the component pages.

Argos Ltd, 489-499 Avebury Boulevard, Central Milton Keynes, MK9 2NW

Capella - Dresser Stool

Assembly Instructions - Please keep for future reference

262/1982

267/6511

264/0877

227/5091

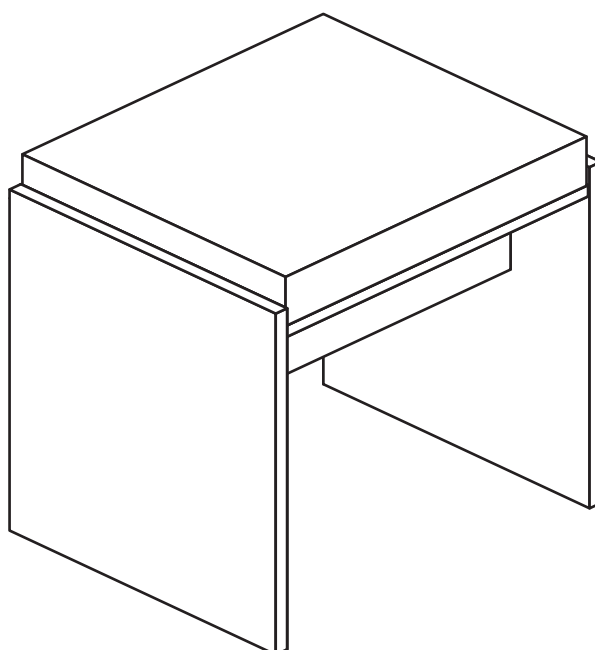

Dimensions

Width - 43cm

Depth - 35.5cm

Height - 48cm



**MADE IN
BRITAIN**

Important - Please read these instructions fully before starting assembly

If you need help or have damaged or missing parts, call the **Customer Helpline: 08456 400800**



Safety and Care Advice

Important - Please read these instructions fully before starting assembly

- **Warning:** This unit weighs approximately 8kgs. Please lift with care.

- Check you have all the components and tools listed on pages 2 and 3.

- Remove all fittings from the plastic bags and separate them into their groups.

- Keep children and animals away from the work area, small parts could choke if swallowed.

- Parts of the assembly will be easier with 2 people.

- Make sure you have enough space to layout the parts before starting.

- Do not stand or put weight on the product, this could cause damage.

- Assemble the item as close to its final position (in the same room) as possible.

- Assemble on a soft level surface to avoid damaging the unit or your floor (use opened out unit carton).



- We do not recommend the use of power drill/drivers **for inserting screws**, as this could damage the unit. Only use hand screwdrivers.

- **Safety note:** If there is any chance of this unit being pulled over by children etc. it is recommended that the unit is secured to a wall using suitable fixings (not supplied).

- Dispose of all packaging carefully and responsibly.

Care and maintenance

- Only clean using a damp cloth and mild detergent, do not use bleach or abrasive cleaners.

- From time to time check that there are no loose screws on this unit.

- This product should not be discarded with household waste. Take to your local authority waste disposal centre.

Note: If required the next page can be cut out and used as reference throughout the assembly. Keep this page with these instructions for future reference.

Components - Panels

If you have damaged or missing components, call the **Customer Helpline: 08456 400800** quoting the reference numbers below

Please check you have all the panels listed below

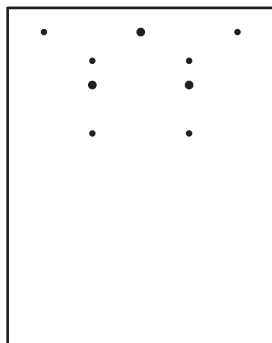

1 Stool Side (D0996A)
(451 x 352mm) x 2

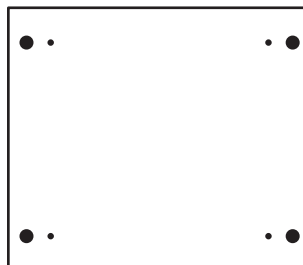

2 Stool Base (D0997A)
(400 x 348mm)

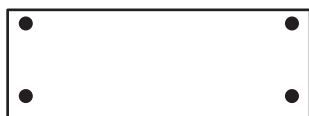

3 Rail (D0998A)
(400 x 144mm) x 2



4 Seat Pad (FMANPAD)
(398 x 348mm)





Components - Fittings

If you have damaged or missing components, call the **Customer Helpline: 08456 400800** quoting the reference numbers below

Please check you have all the fittings listed below

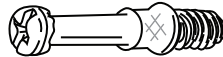
Note: The quantities below are the correct amount to complete the assembly. In some cases more fittings may be supplied than are required.

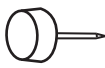
<p>A </p> <p>Wooden dowel (F22) x 6</p>	<p>B </p> <p>Metal dowel (F901) x 12</p>	
<p>C </p> <p>Large locking nut (F900) x 12</p>	<p>D </p> <p>25mm Screw (F50) x 4</p>	<p>E </p> <p>Plastic Nail (F91) x 4</p>

Tools required

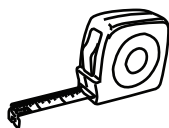

Rule



Cross-head screwdriver



Scissors



Hammer



Eye protection (when using a hammer or drill)

Ruler - Use this ruler to help correctly identify the screws

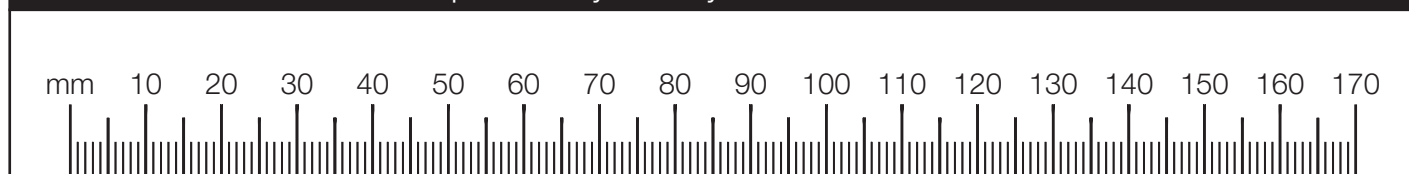

Assembly Instructions

If you have damaged or missing components, call the
Customer Helpline: 08456 400800 quoting the reference
numbers below

Step 1

Prepare the 2 stool sides

Screw 6 metal dowels **B** into each of the 2 stool sides **1**, as shown.

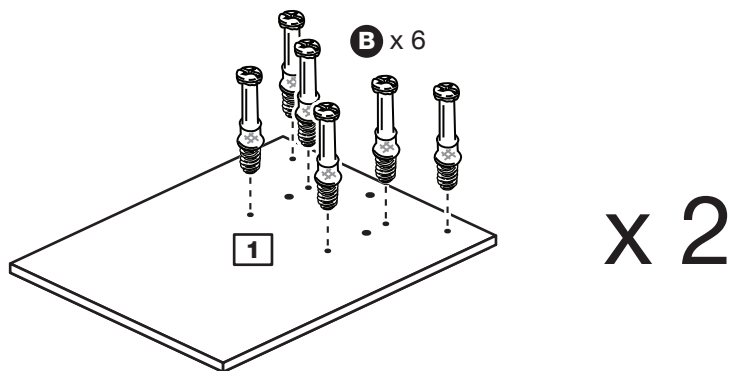

Step 2

Prepare the stool base

Insert 4 large locking nuts **C** into the holes in the stool base **2**.

Tap 2 wooden dowels **A** into the ends of the stool base **2**.

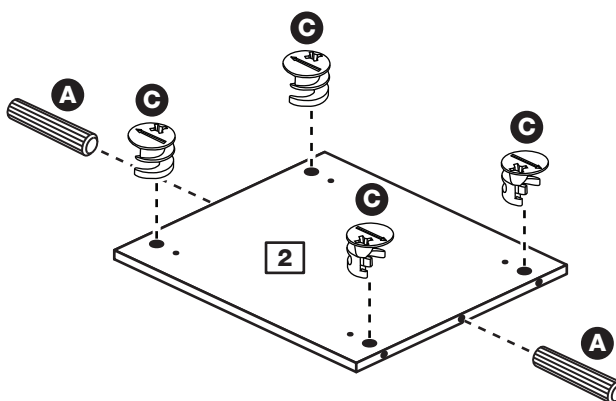

Step 3

Fit a stool side to the stool base

Fit one of the stool sides **1** to the stool base **2**.

Use a screwdriver to tighten the 2 large locking nuts **C** fitted to the stool base **2**.

Note: Turn the large locking nuts **C** as far as they will go - more than 1/2 a turn.

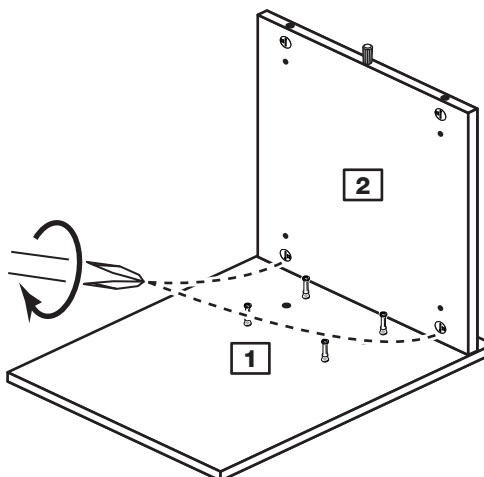

Step 4

Prepare the 2 rails

Insert 4 large locking nuts **C** into each of the 2 rails **3**.

Tap 2 wooden dowels **A** into each rail **3**.

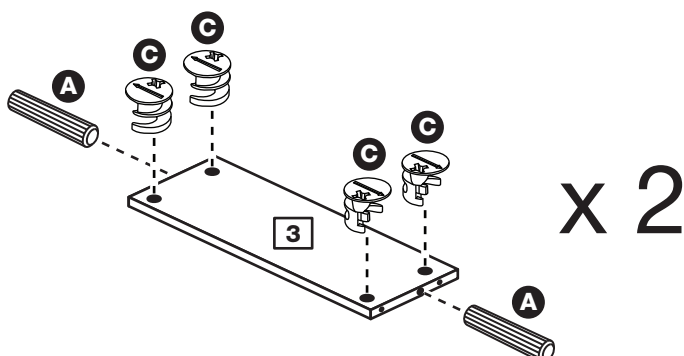

Assembly Instructions

Step 5

Fit the rails

Push the 2 rails **3** down onto the stool side **1**, as shown.

Use a screwdriver to tighten the 2 large locking nuts **C** fitted to each rail **3**.

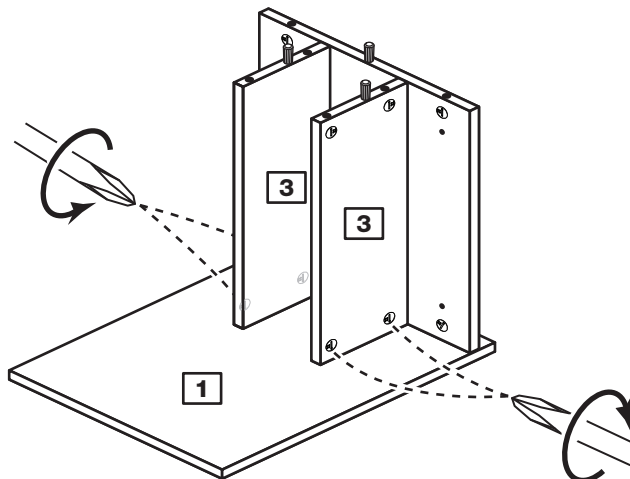

Step 6

Fit the other stool side

a: Push the other stool side **1** down onto the assembly, as shown.

Use a screwdriver to tighten the 2 large locking nuts **C** fitted to the stool base **2**.

a:

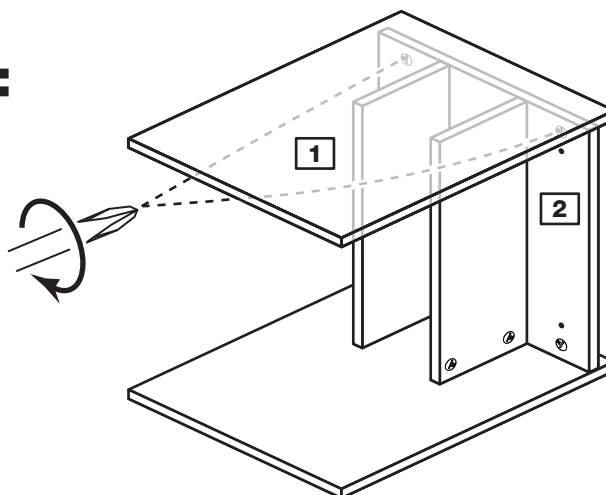

b: Use a screwdriver to tighten the 2 large locking nuts **C** fitted to each of the rails **3**.

b:

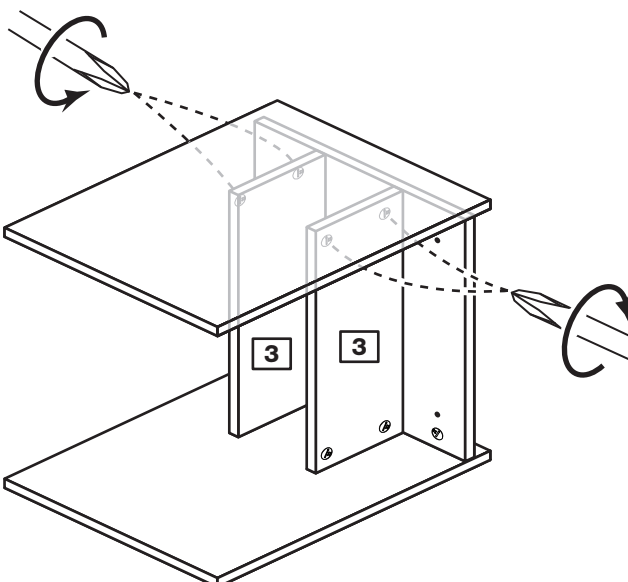

Assembly Instructions

Step 7

Fit the seat pad

Position the seat pad **4** onto the assembly and make sure that its 4 edges line up with the stool base **2**.

Hold the seat pad **4** in position and screw up through the 4 holes in the stool base **2** using screws **D**.

Note: Make sure that you screw into the hard surface of the seat pad.

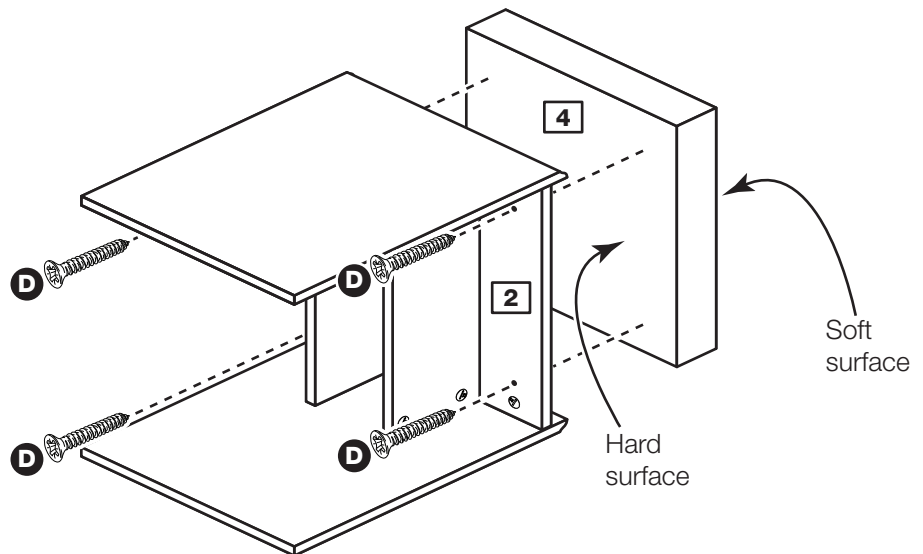

Step 8

Fit the 4 plastic nails

Tap 2 plastic nails **E** into the bottom edge of each of the sides **1**.

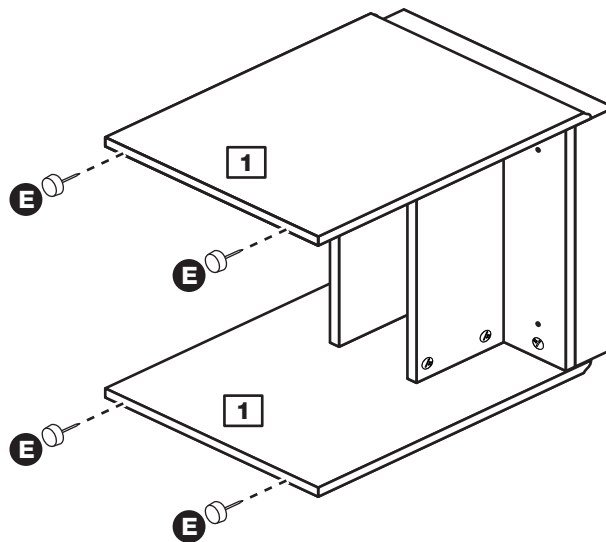

Step 9

Assembly is complete

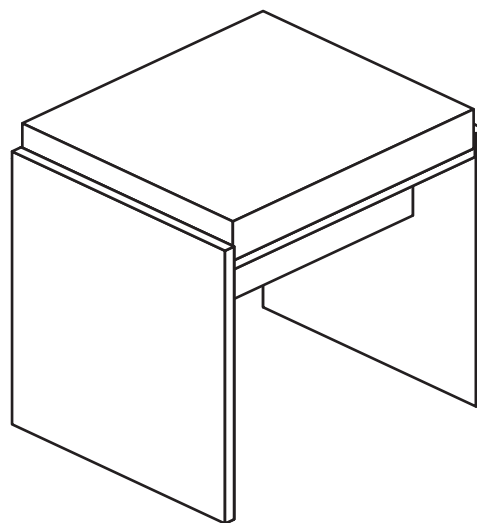

If you need help or have damaged or missing parts, call the Customer Helpline: 08456 400800 and quote the reference numbers on the component pages.

Argos Ltd, 489-499 Avebury Boulevard, Central Milton Keynes, MK9 2NW

