

Capella - 2+2 Sliding Robe

Assembly Instructions - Please keep for future reference

268/1647

259/4071

262/0488

244/0273

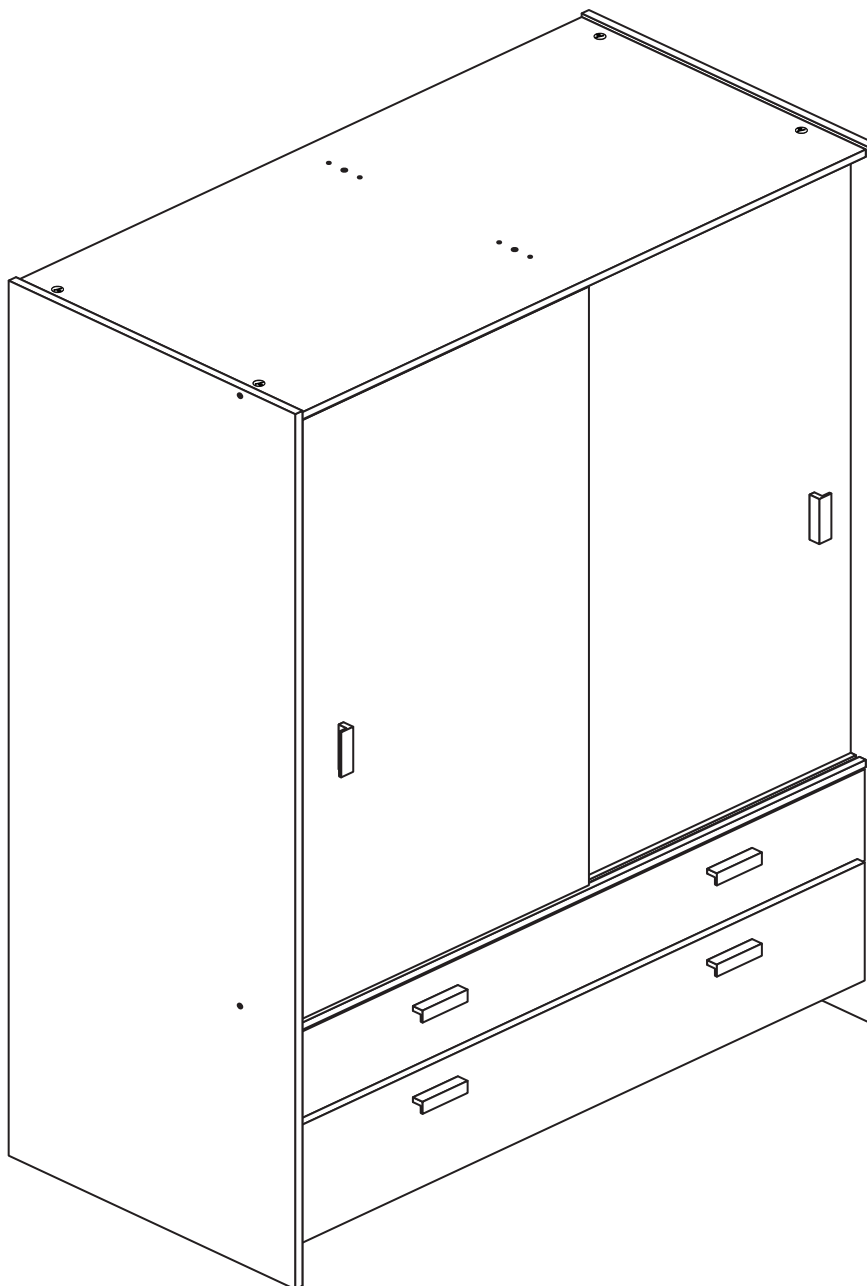

Dimensions

Width - 120cm

Depth - 59.5cm

Height - 181cm



**MADE IN
BRITAIN**

Important - Please read these instructions fully before starting assembly

If you need help or have damaged or missing parts, call the **Customer Helpline: 08456 400800**



Safety and Care Advice

Important - Please read these instructions fully before starting assembly

- **Warning:** This unit weighs approximately 79kgs. Please lift with care.
- Check you have all the components and tools listed on pages 1, 2 and 3.
- Remove all fittings from the plastic bags and separate them into their groups.
- Keep children and animals away from the work area, small parts could choke if swallowed.
- Parts of the assembly will be easier with 2 people.

- Make sure you have enough space to layout the parts before starting.
- Do not stand or put weight on the product, this could cause damage.
- Assemble the item as close to its final position (in the same room) as possible.
- Assemble on a soft level surface to avoid damaging the unit or your floor (use opened out unit carton).



• We do not recommend the use of power drill/drivers **for inserting screws**, as this could damage the unit. Only use hand screwdrivers.

• **Safety note:** It is recommended that this unit is secured to a wall using the bracket supplied.

• Dispose of all packaging carefully and responsibly.

Care and maintenance

- Only clean using a damp cloth and mild detergent, do not use bleach or abrasive cleaners.
- From time to time check that there are no loose screws on this unit.
- This product should not be discarded with household waste. Take to your local authority waste disposal centre.

Components - Panels

If you have damaged or missing components, call the **Customer Helpline: 08456 400800** quoting the reference numbers below

Please check you have all the panels listed below

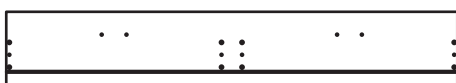

1 Top Drawer Front (D2716A)
(1165 x 185mm)

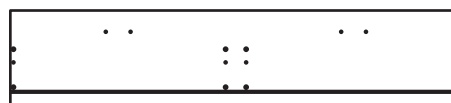

2 Bottom Drawer Front (D2718A)
(1165 x 244mm)



3 Top Left Drawer Side (W370-124LH)
(370 x 124mm) x 2



4 Top Right Drawer Side (W370-124RH)
(370 x 124mm) x 2



5 Bottom Left Drawer Side (W370-165LH)
(370 x 165mm) x 2



6 Bottom Right Drawer Side (W370-165RH)
(370 x 165mm) x 2



7 Top Drawer Back (W526-124)
(526 x 124mm) x 2



8 Bottom Drawer Back (W526-165)
(526 x 165mm) x 2



9 Drawer Base (T537-367)
(537 x 367mm) x 4

Components - Panels

If you have damaged or missing components, call the **Customer Helpline: 08456 400800** quoting the reference numbers below

Please check you have all the panels listed below

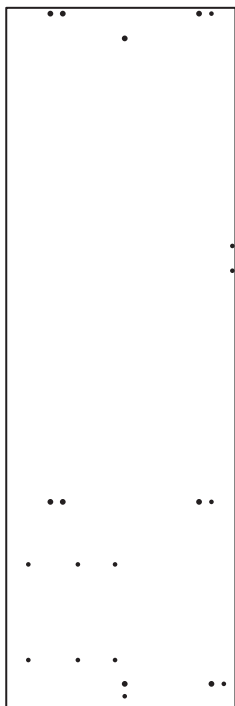

10 Left Side (D2710A)
(1808 x 592mm)

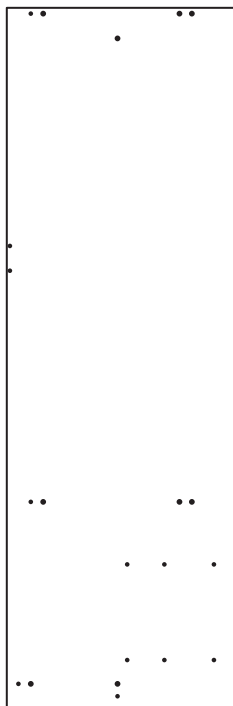

11 Right Side (D2711A)
(1808 x 592mm)

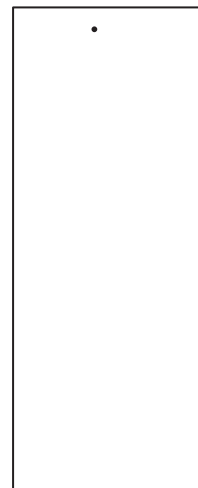

12 Large Divider (D2712A)
(1246 x 496mm)

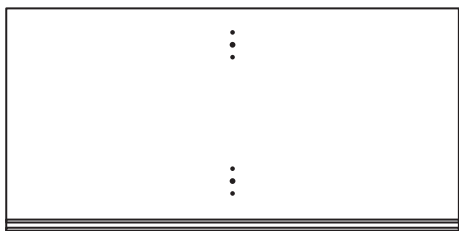

13 Top/Base (D2709A)
(1169 x 587mm) x 2

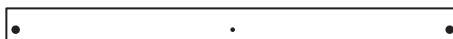

14 Rail (D2714A)
(1169 x 85mm) x 2

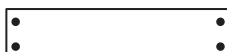

15 Back Rail (D2715A)
(577 x 120mm) x 2

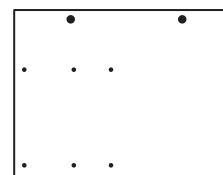

16 Small Divider (D2713A)
(437.5 x 560mm)

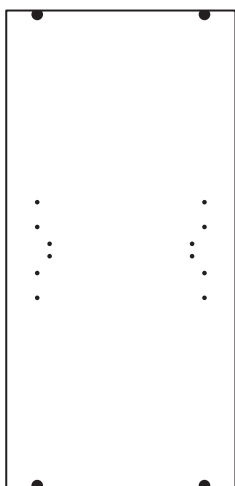

17 Door (D2717A)
(1237 x 592mm) x 2



18 Hanging Rail (FHR569)
(566mm long) x 2

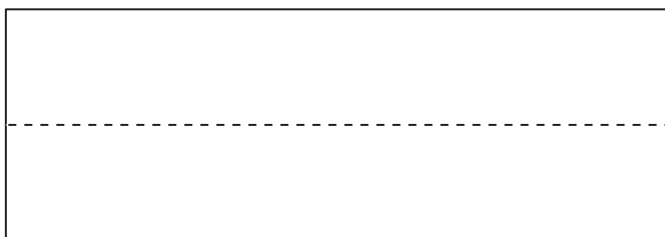

19 Back (X1722-597)
(1722 x 597mm) x 2











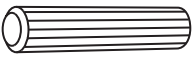
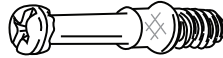

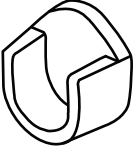
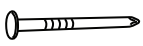



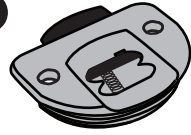
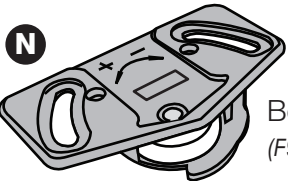
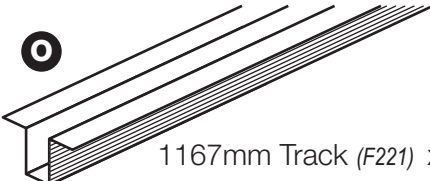

Components - Fittings

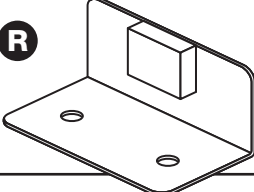
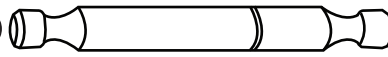
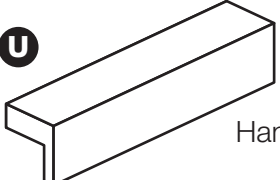
If you have damaged or missing components, call the **Customer Helpline: 08456 400800** quoting the reference numbers below

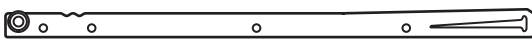
Please check you have all the fittings listed below

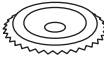
Note: The quantities below are the correct amount to complete the assembly. In some cases more fittings may be supplied than are required.

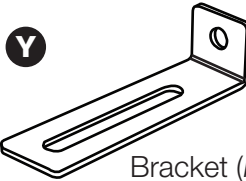
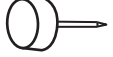
<p>A </p> <p>Wooden dowel (F22) x 16</p>	<p>B </p> <p>Metal dowel (F901) x 22</p>	<p>C </p> <p>Large locking nut (F900) x 22</p>		
<p>D </p> <p>Small locking nut (F3) x 8</p>	<p>E </p> <p>Rail holder (F1014) x 4</p>	<p>F </p> <p>Nail (F51) x 40</p>		
<p>G </p> <p>40mm Screw (F910) x 4</p>	<p>H </p> <p>25mm Screw (F50) x 12</p>	<p>I </p> <p>13mm Screw (F79) x 1</p>	<p>J </p> <p>13mm Screw (F63) x 38</p>	
<p>K </p> <p>9mm Screw (F73) x 24</p>	<p>L </p> <p>45mm Screw (F65) x 1</p>	<p>M </p> <p>Top glide (F956) x 4</p>		
<p>N </p> <p>Bottom glide (F952) x 4</p>	<p>O </p> <p>1167mm Track (F221) x 4</p>	<p>P </p> <p>Knock-in Peg (F1716Y) x 16</p>		
<p>Q </p> <p>Mushroom Head Pin (F260) x 4</p>	<p>R </p> <p>Buffer bracket (F261) x 1</p>	<p>S </p> <p>Double metal dowel (F566) x 2</p>		
<p>U </p> <p>Handle (F930) x 6</p>	<p>T a  L Runner (F159) x 4 ← 350mm long →</p> <p>T b  R Runner (F160) x 4</p> <p>T c  L Runner (F161) x 4</p> <p>T d  R Runner (F162) x 4</p>			
<p>V </p> <p>Nail screw (F277) x 5</p>	<p>W </p> <p>Back holder (F276) x 5</p>	<p>X </p> <p>Wedgefix (F639) x 16</p>	<p>Y </p> <p>Bracket (F327) x 1</p>	<p>Z </p> <p>Plastic Nail (F91) x 6</p>

Assembly Instructions

If you have damaged or missing components, call the
Customer Helpline: 08456 400800 quoting the reference
numbers below

Step 1

Prepare the 4 top drawer sides

Insert a small locking nut **D** into the hole shown on each of the 2 top left drawer sides **3** and 2 top right drawer sides **4**.

Note: The arrow on the locking nut **must** point towards the hole in the edge of the panel.

Note: Due to the manufacturing process, the holes for the locking nut can be on either surface of the drawer sides.

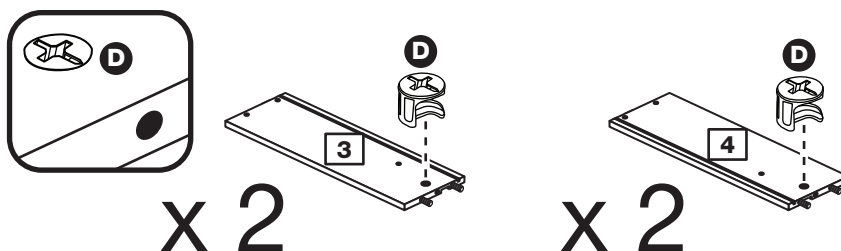

Step 2

Fit the top drawer sides to the top drawer backs

Make sure that the grooves on the inside of the drawer assembly line up.

a: With the top drawer back **7** in an upright position tap 2 knock-in pegs **P** through the holes in the top left drawer side **3**.

Turn the assemblies over

b: Hold the top drawer back **7** in position and tap 2 knock-in pegs **P** through the holes in the top right drawer side **4**.

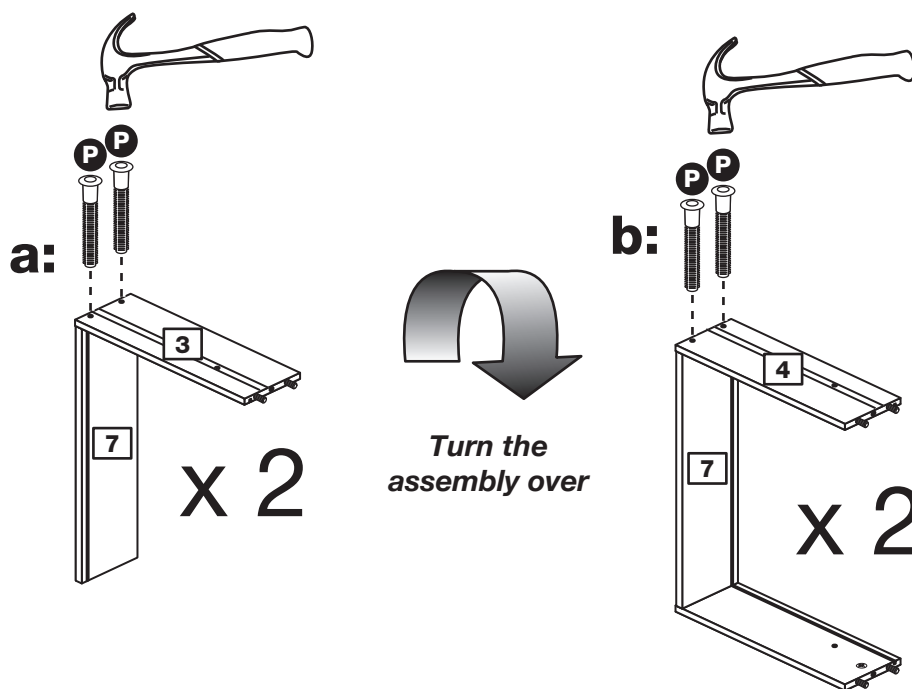

Step 3

Fit the drawer bases

Slide the drawer base **9** down the grooves in the top drawer sides **3** and **4** and down into the groove in the top drawer back **7**.

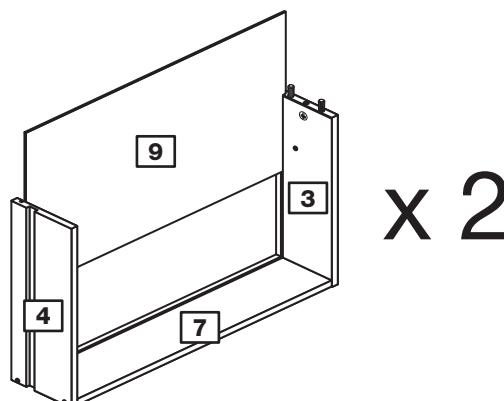

Assembly Instructions

Step 4

Prepare the top drawer front

Screw 4 metal dowels **B** into the top drawer front **1**.

Note: Tighten the metal dowels up fully against the panels.

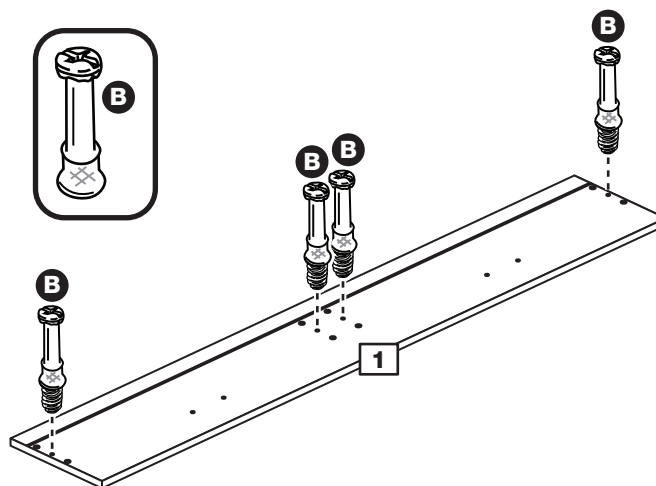

Step 5

Fit the drawer front

Lower the 2 top drawer assemblies down onto the back of the top drawer front **1**.

Use a screwdriver to tighten the 4 small locking nuts **D** fitted to the drawer sides.

Note: Turn the small locking nuts **D** as far as they will go - more than 1/2 a turn.

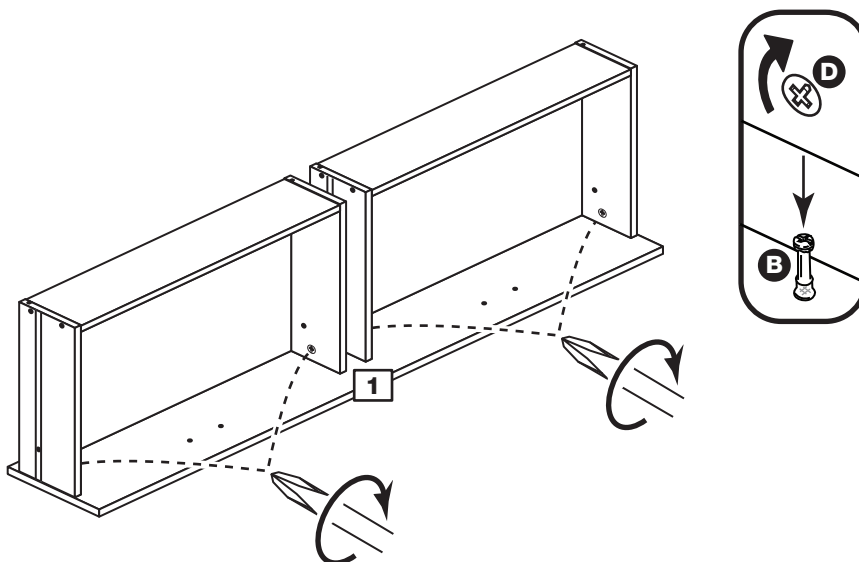

Step 6

Attach the handles

Attach 2 handles **U** to the top drawer front **1** using screws **H**.

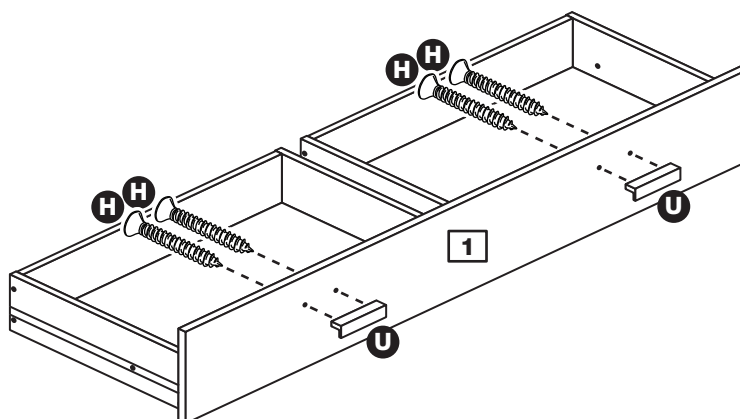

Assembly Instructions

Step 7

Fit the runners and the wedgfixes

Turn the top drawer assembly over.

a: Fit a runner **Tc** to the bottom edge of the top left drawer side **3**, as shown, making sure that it is pushed up against the back of the top drawer front **1**. Use a bradawl to mark the fixing positions, then secure with 2 screws **J**.

Fit a runner **Td** to the bottom edge of the top right drawer side **4** using the same method.

b: Repeat the instructions above to fit the runners to the other top drawer sides.

c: Slide 2 wedgfixes **X** along each drawer base **9** and into the small groove on the back of the top drawer front **1**. Slide 2 more wedgfixes **X** along each drawer base **9** and into the small groove on the back of the top drawer back **7**.

Once in place, tighten up the screws.

Runners must be pushed up against the drawer front

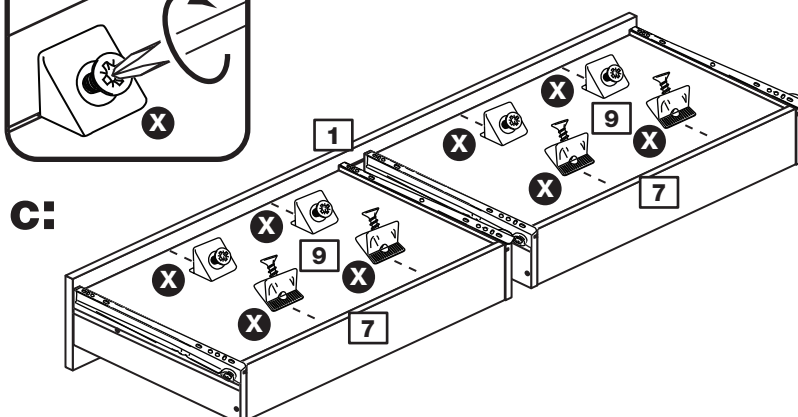
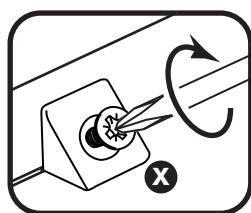
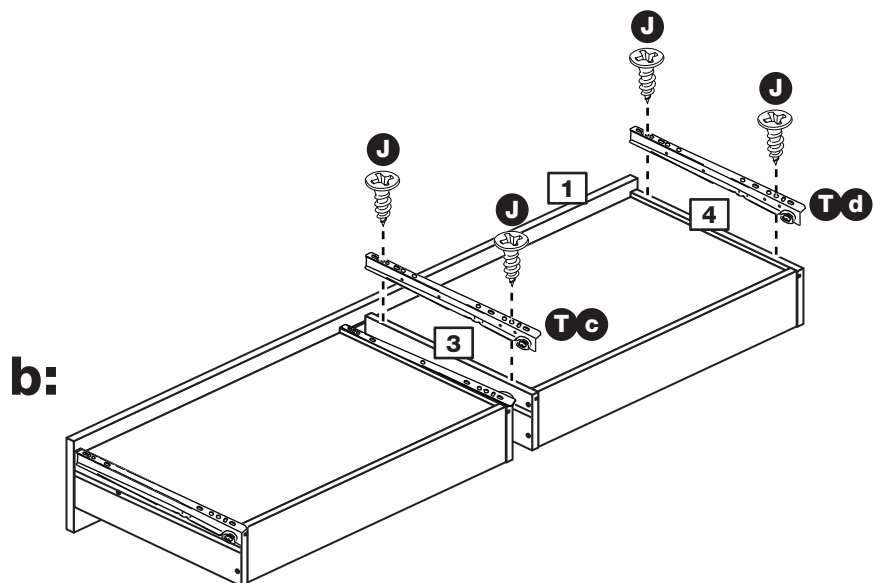
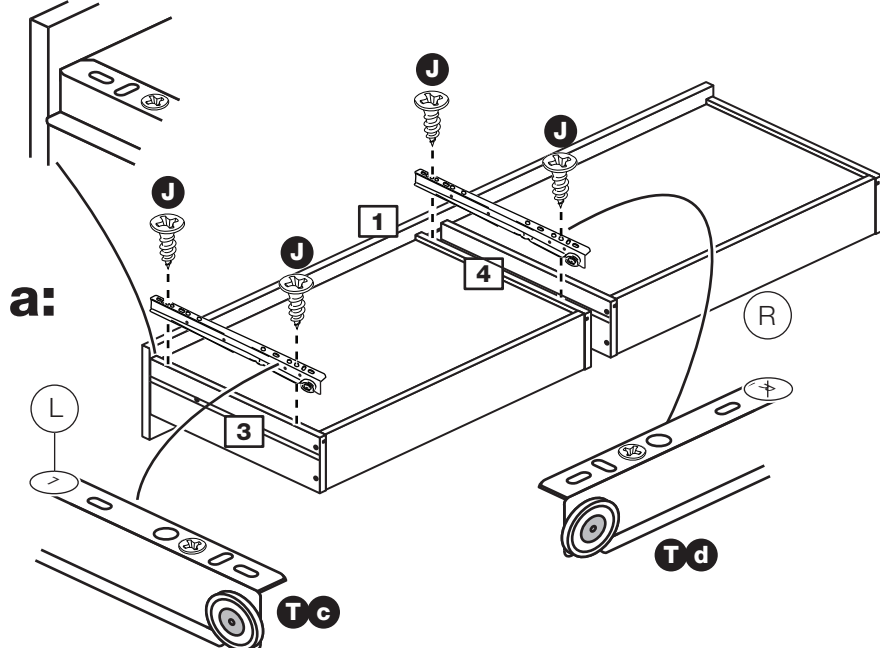

Assembly Instructions

Step 8

Prepare the 4 bottom drawer sides

Insert a small locking nut **D** into the hole shown on each of the 2 bottom left drawer sides **5** and 2 bottom right drawer sides **6**.

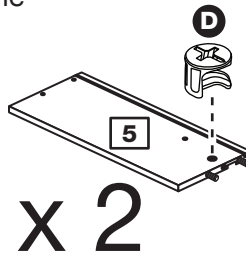
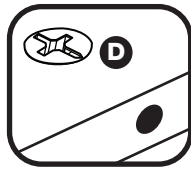

x 2

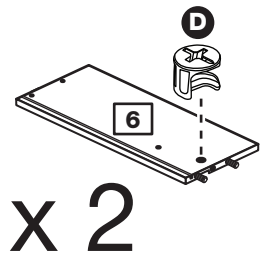

x 2

Note: The arrow on the locking nut **must** point towards the hole in the edge of the panel.

Step 9

Fit the bottom drawer sides to the bottom drawer backs

Make sure that the small grooves on the inside of the drawer assembly line up.

a: With the bottom drawer back **8** in an upright position tap 2 knock-in pegs **P** through the holes in the bottom left drawer side **5**.

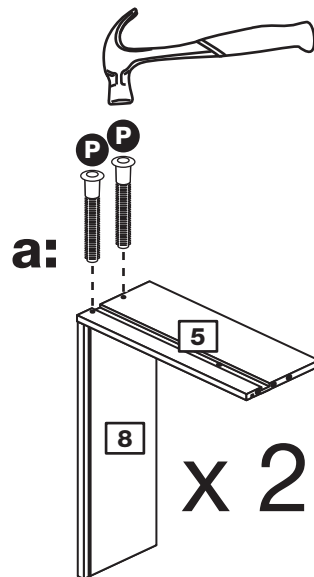

x 2



Turn the assembly over

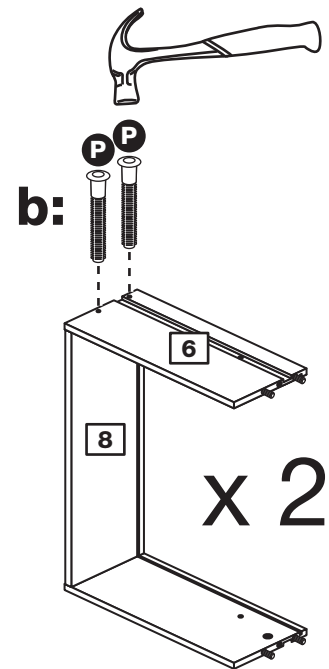

x 2

Turn the assemblies over

b: Hold the bottom drawer back **8** in position and tap 2 knock-in pegs **P** through the holes in the bottom right drawer side **6**.

Step 10

Fit the drawer bases

Slide the drawer base **9** down the grooves in the bottom drawer sides **5** and **6** and down into the groove in the bottom drawer back **8**.

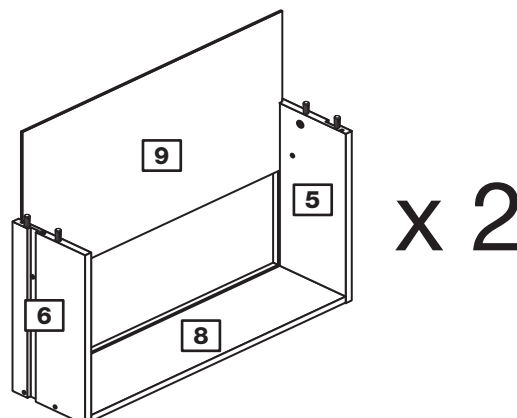

x 2

Assembly Instructions

Step 11

Prepare the bottom drawer front

Screw 4 metal dowels **B** into the bottom drawer front **2**.

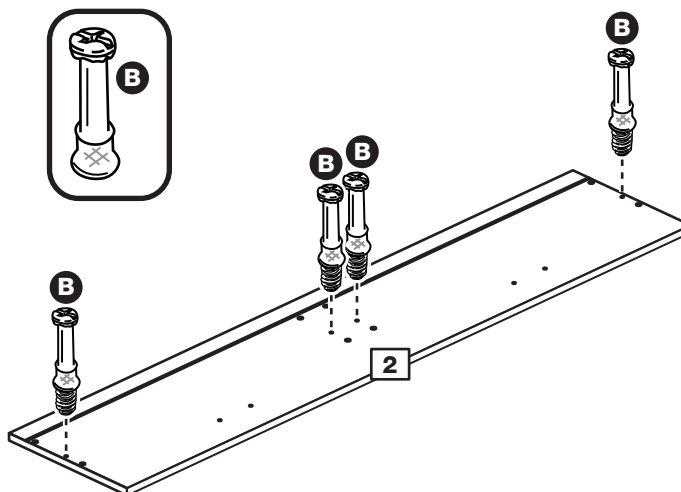

Step 12

Fit the drawer front

Lower the 2 bottom drawer assemblies down onto the back of the bottom drawer front **2**.

Use a screwdriver to tighten the 4 small locking nuts **D** fitted to the drawer sides.

Note: Turn the small locking nuts **D** as far as they will go - more than 1/2 a turn.

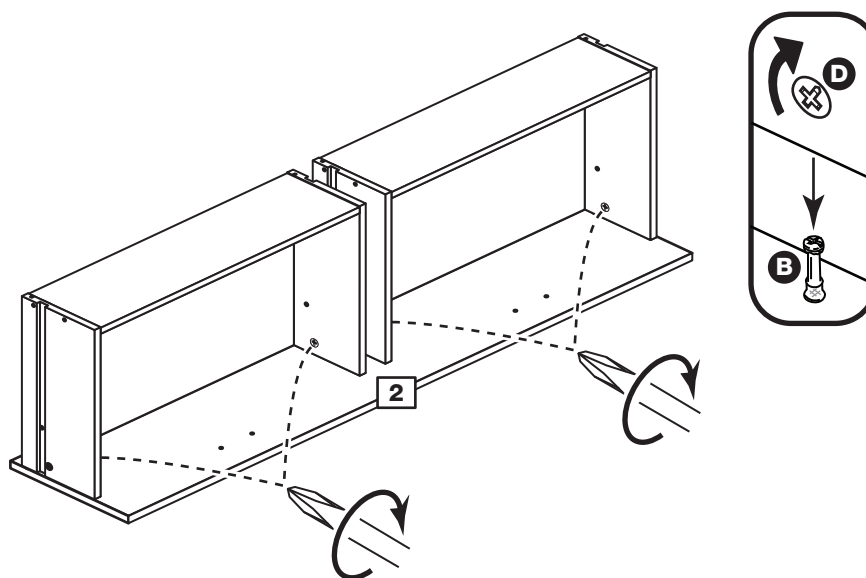

Step 13

Attach the handles

Attach 2 handles **U** to the bottom drawer front **2** using screws **H**.

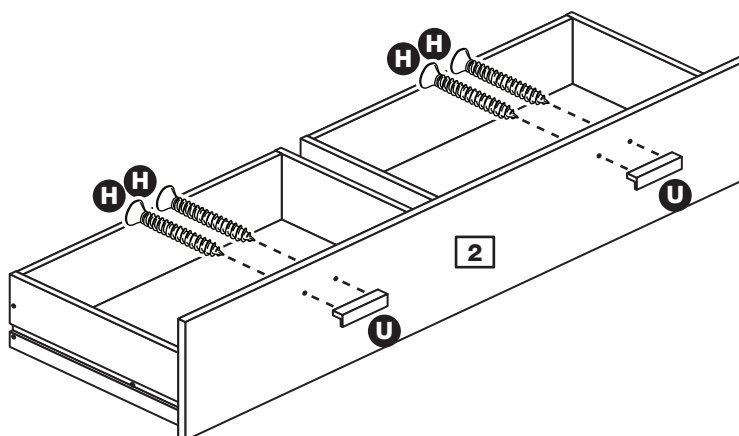

Assembly Instructions

Step 14

Fit the runners and the wedgexes

Turn the bottom drawer assembly over.

a: Fit a runner **Tc** to the bottom edge of the bottom left drawer side **5**, as shown, making sure that it is pushed up against the back of the bottom drawer front **2**. Use a bradawl to mark the fixing positions, then secure with 2 screws **J**.

Fit a runner **Td** to the bottom edge of the bottom right drawer side **6** using the same method.

b: Repeat the instructions above to fit the runners to the other bottom drawer sides.

c: Slide 2 wedgexes **X** along each drawer base **9** and into the small groove on the back of the bottom drawer front **2**.

Slide 2 more wedgexes **X** along each drawer base **9** and into the small groove on the back of the bottom drawer back **8**.

Once in place, tighten up the screws.

Runners must be pushed up against the drawer front

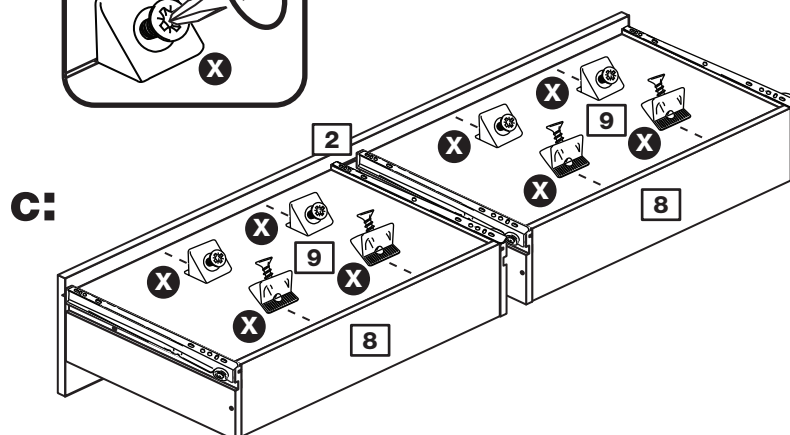
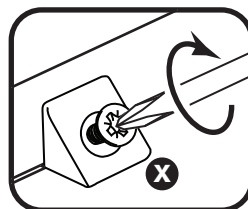
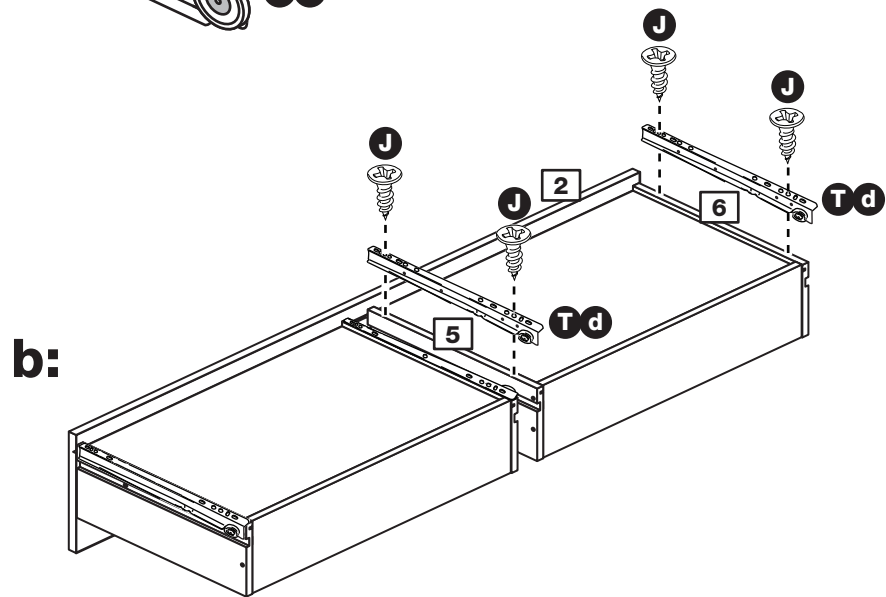
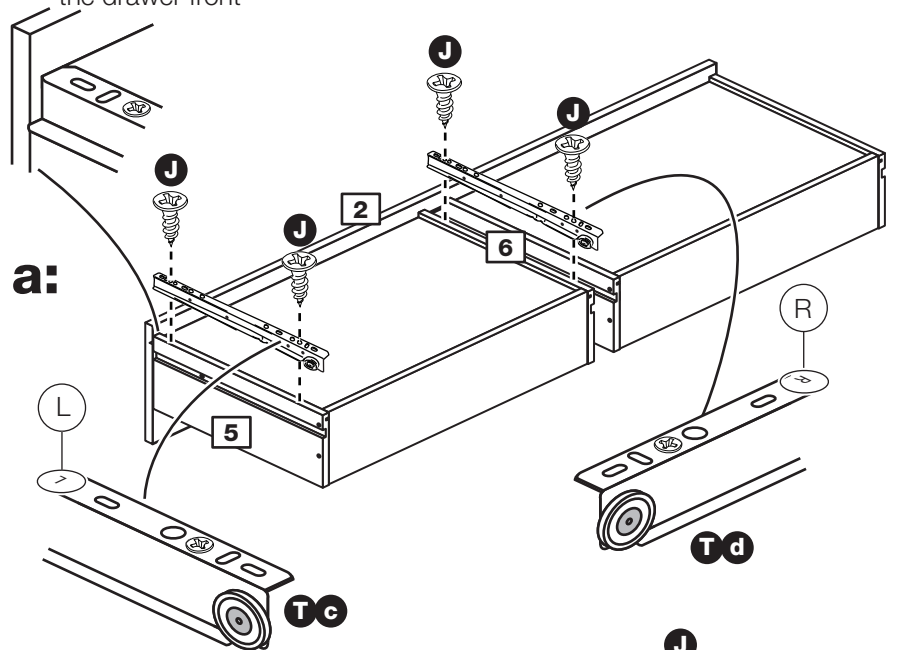

Assembly Instructions

Step 15

Prepare the top and base

Place 2 plastic tracks **O** down onto each of the top **13** and base **13** panels, making sure that they are flush with the edges of the panel.

Gently tap along the length of the plastic tracks **O** until they are fitted flat to the surface of the panel.

Turn the top and the base panels over

Tap 4 wooden dowels **A** into each of the top **13** and base **13** panels.

Note: Wooden dowels **must not** stick out from the edge by more than 10mm or they may damage other panels.

Insert 4 large locking nuts **C** into each of the top **13** and base **13** panels.

Note: The arrow on the locking nut **must** point towards the hole in the edge of the panel.

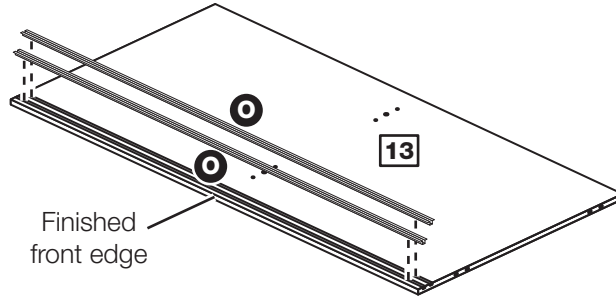
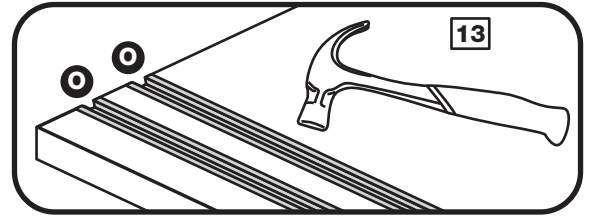

x 2

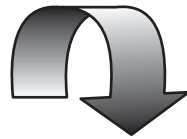

Turn the top and the base over

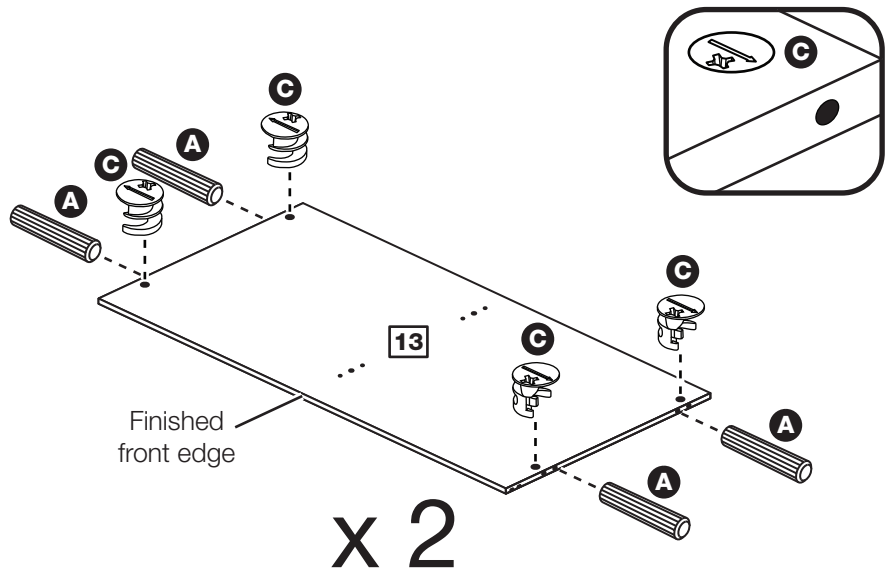

x 2

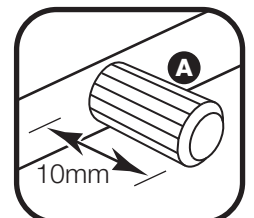

Assembly Instructions

Step 16

Finish preparing the base

Take 1 of the top/base **13** panels you have just prepared and screw in 2 metal dowels **B**.

This will now be used as the base.

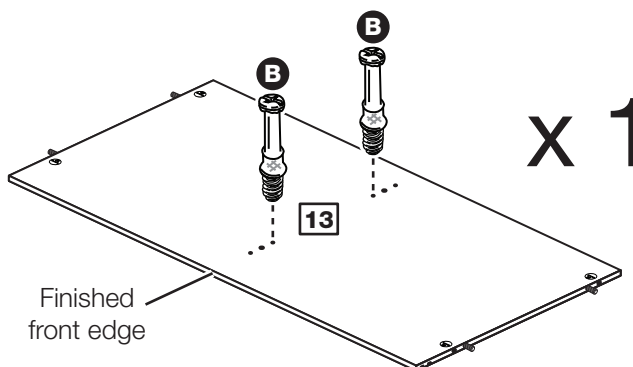

Step 17

Prepare the large divider

Push a rail holder **E** into the large divider **12**. Make sure that it is fitted straight, in line with the panel edges and then secure with screw **J**.

Tap 4 wooden dowels **A** into the large divider **12**.

Turn the large divider over

Push a rail holder **E** into the other surface of the large divider **12**. Make sure that it is fitted straight, in line with the panel edges and then secure with screw **J**.

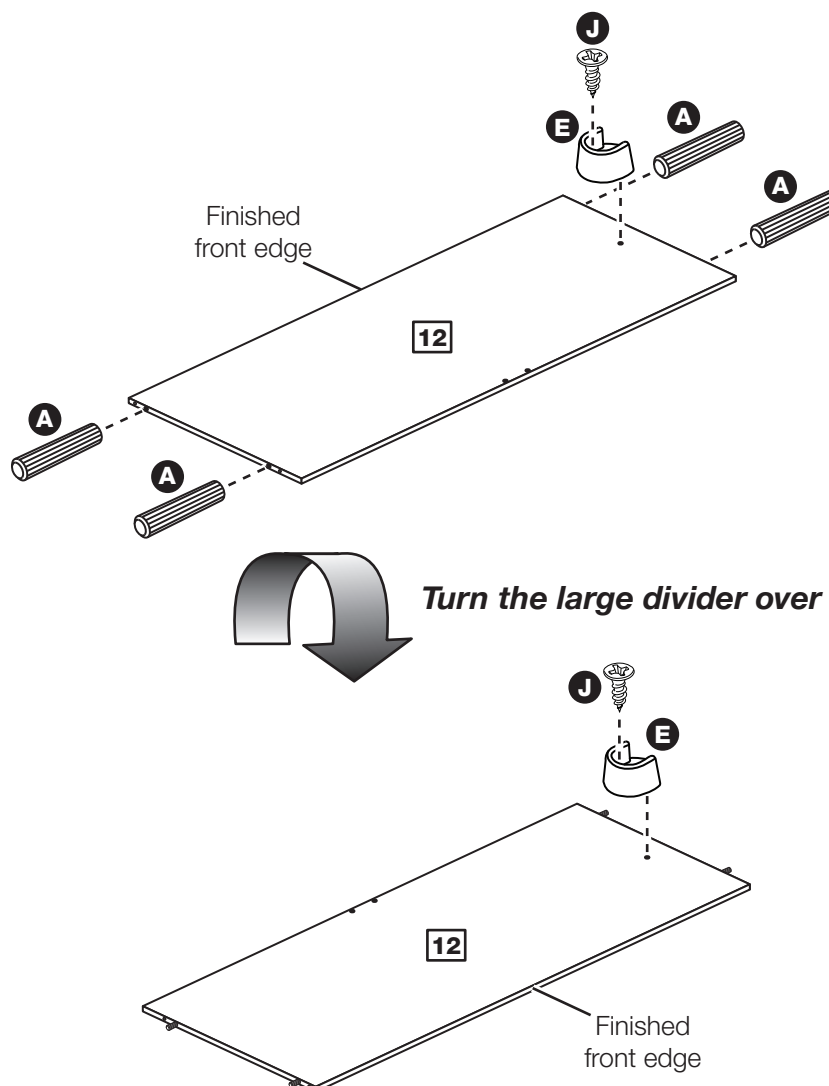

Assembly Instructions

Step 18

Fit top and base to the divider

Attach the top **13** and base **13** to the large divider **12** using 4 screws **G**.

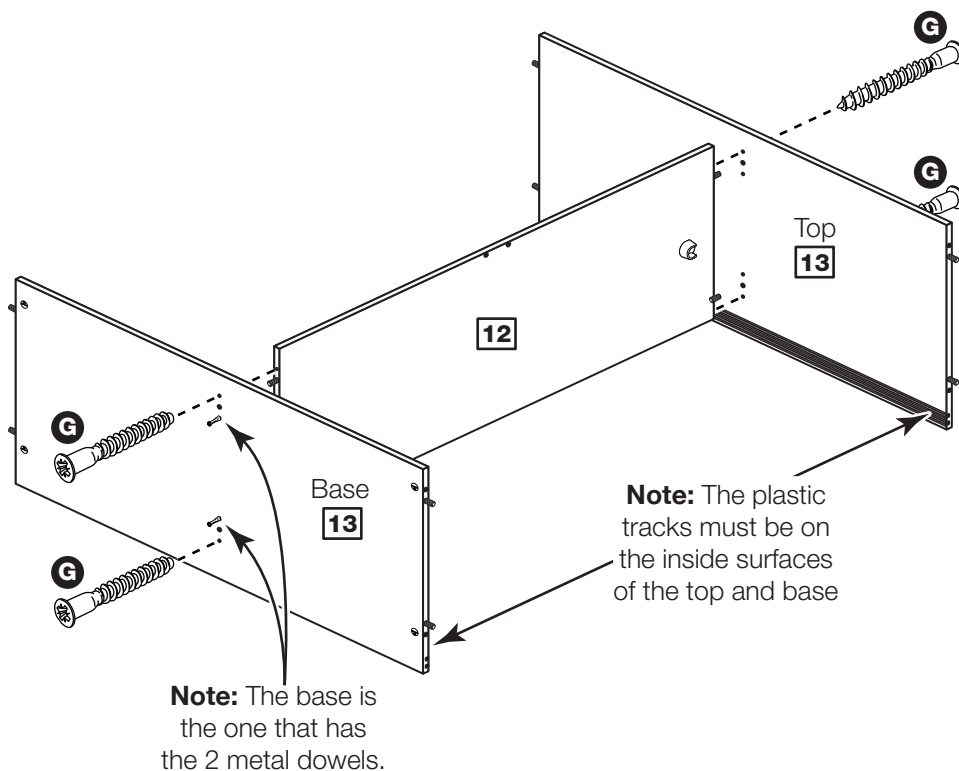

Step 19

Prepare the back rails

Insert 4 large locking nuts **G** into each of the 2 back rails **15**.

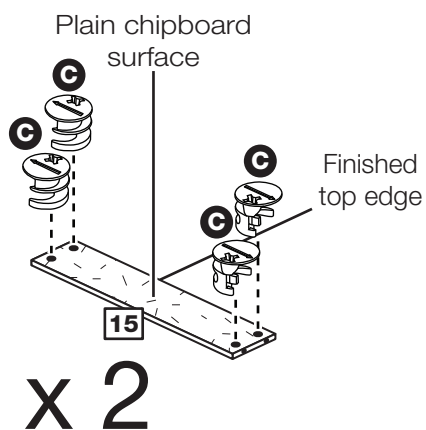

Assembly Instructions

Step 20

Prepare the right side

a: Fit 2 runners **T b** to the right side **11**.

The 1st screw **K** uses the 1st hole in from the front of the runner.

The 2nd and 3rd screws **K** use the holes that line up with the other panel holes.

Push a rail holder **E** into the right side **11**. Make sure that it is fitted straight, in line with the panel edges and then secure with screw **J**.

b: Fit a screw **J** into the 2nd hole in at the top of the runner **T b**.

Screw 6 metal dowels **B** into the right side **11**.

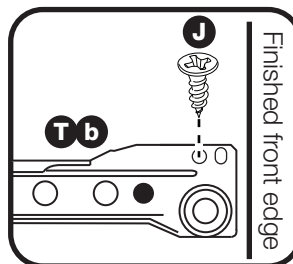
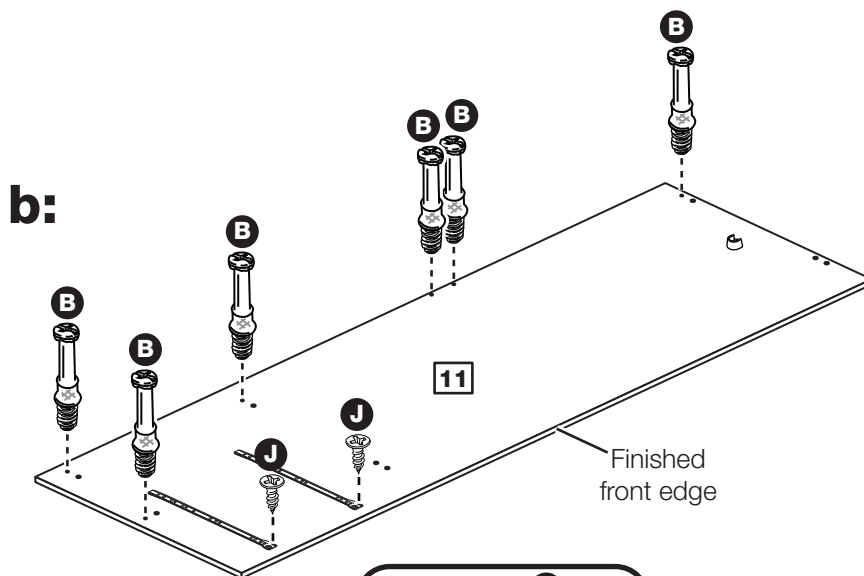
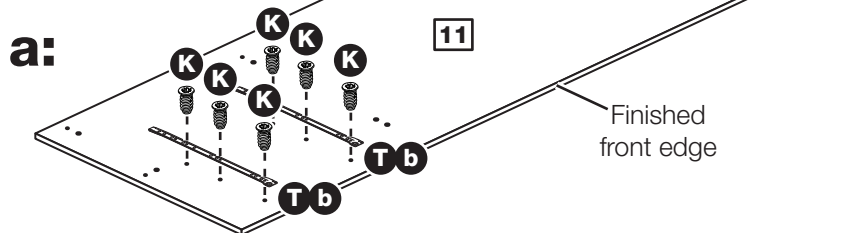
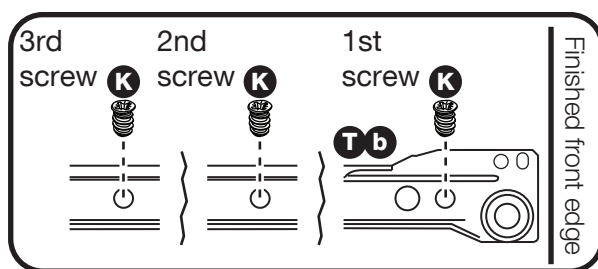

Assembly Instructions

Step 21

Fit a back rail

a: Push a back rail **15** onto the large divider **12**.

Tap 2 double metal dowels **S** through the large divider **12** and into the back rail **15** until they "bottom out".

b: Use a screwdriver to tighten the 2 large locking nuts **C** fitted to the back rail **15**.

Note: Turn the large locking nuts **C** as far as they will go - more than 1/2 a turn.

Note: Support the back rail until the right side has been fitted in the next step.

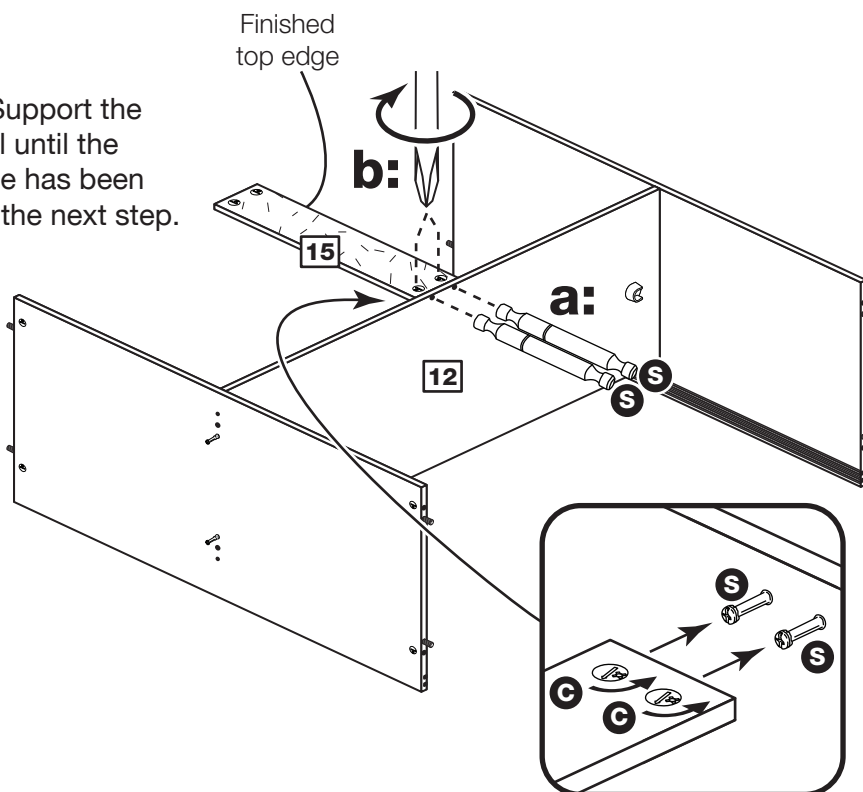

Step 22

Fit the right side

Push the right side **11** onto the assembly.

Use a screwdriver to tighten the 4 large locking nuts **C** fitted to the back rail **15**, top **13** and base **13**.

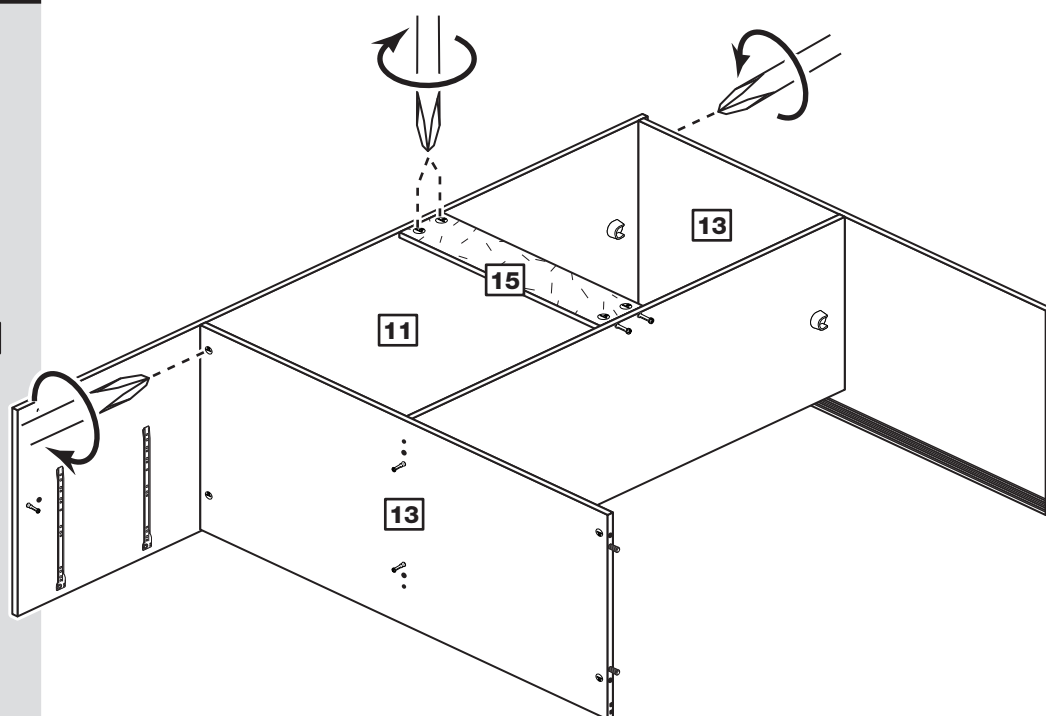

Assembly Instructions

Step 23

Fit the mushroom head pins

a: Tap 2 mushroom head pins **a** into the holes on the outside of the right side **11** and into the top **13** and base **13**.

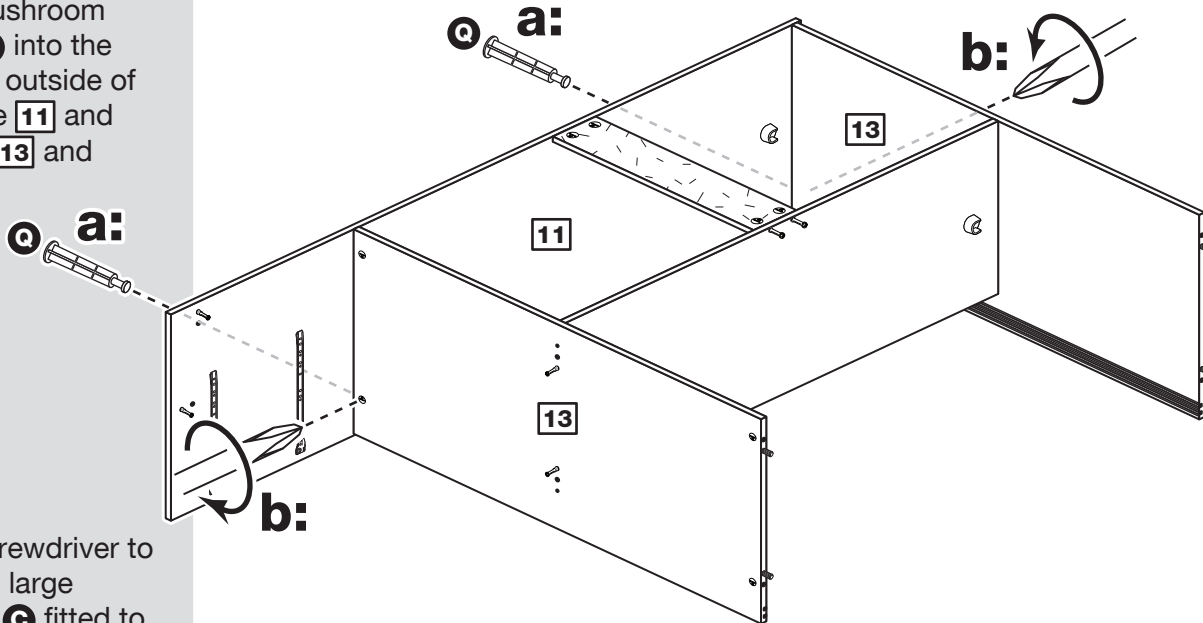

b: Use a screwdriver to tighten the 2 large locking nuts **c** fitted to the top **13** and base **13**.

Step 24

Prepare the 2 rails

Tap 2 wooden dowels **A** into each of the 2 rails **14**.

Insert 2 large locking nuts **c** into each of the 2 rails **14**.

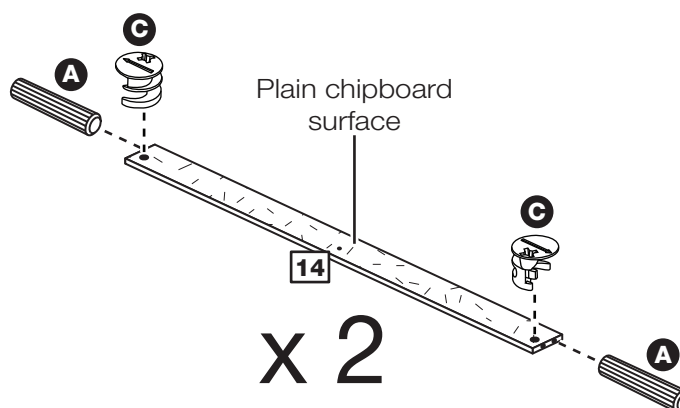

Assembly Instructions

Step 25

Prepare the small divider

a: Fit 2 runners **T a** to the small divider **16**.

The 1st screw **K** uses the 1st hole in from the front of the runner.

The 2nd and 3rd screws **K** use the holes that line up with the other panel holes.

b: Fit a screw **J** into the 2nd hole in at the top of the runner **T a**.

Insert 2 large locking nuts **C** into the small divider **16**.

Turn the small divider over

c: Fit 2 runners **T b** to the small divider **16**.

The 1st screw **K** uses the 1st hole in from the front of the runner.

The 2nd and 3rd screws **K** use the holes that line up with the other panel holes.

d: Fit a screw **J** into the 2nd hole in at the top of the runner **T b**.

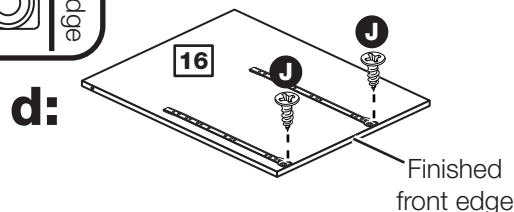
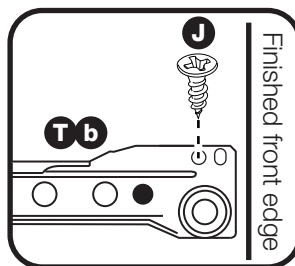
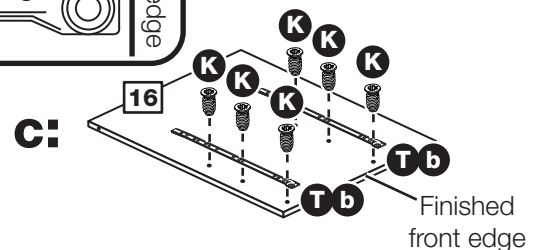
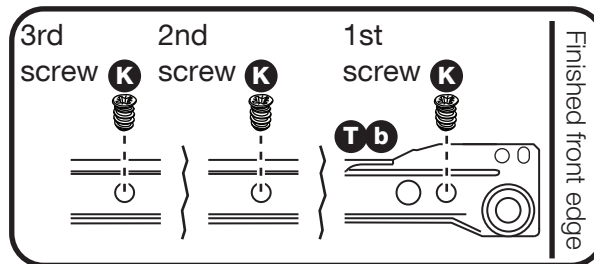
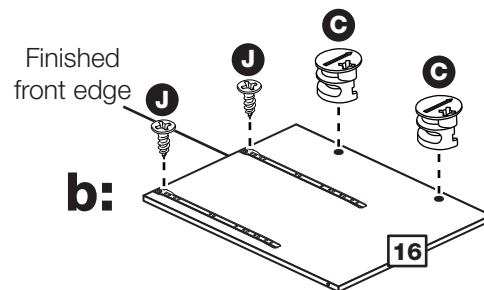
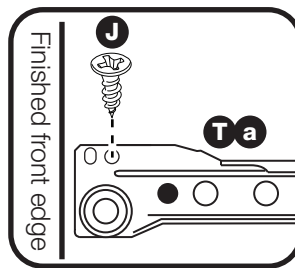
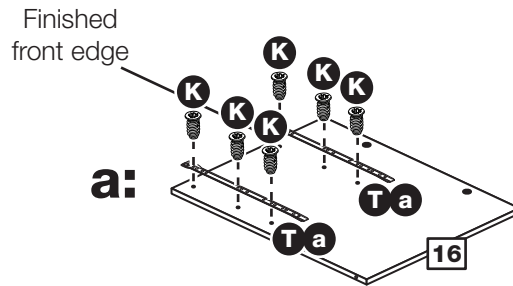
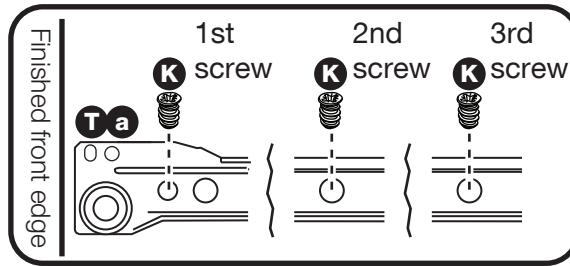

Assembly Instructions

Step 26

Prepare the left side

a: Fit 2 runners **T a** to the left side **10**.

The 1st screw **K** uses the 1st hole in from the front of the runner.

The 2nd and 3rd screws **K** use the holes that line up with the other panel holes.

Push a rail holder **E** into the left side **10**. Make sure that it is fitted straight, in line with the panel edges and then secure with screw **J**.

b: Fit a screw **J** into the 2nd hole in at the top of the runner **T a**.

Screw 6 metal dowels **B** into the left side **10**.

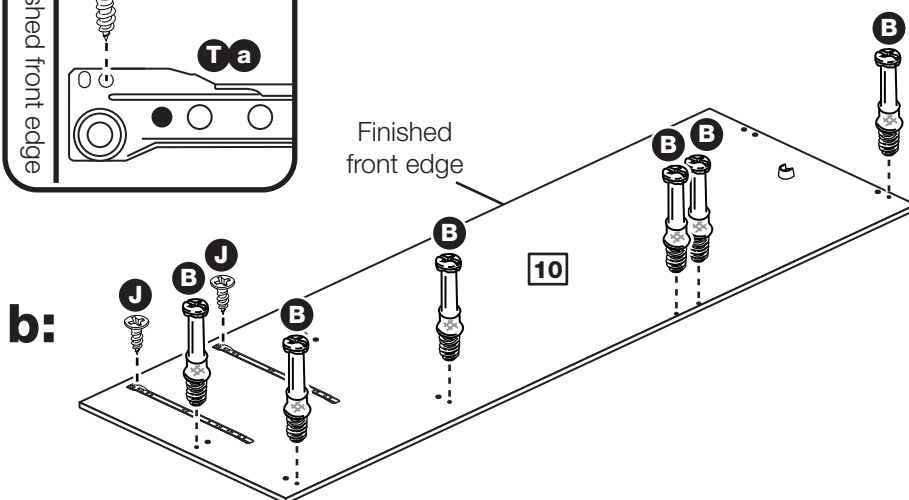
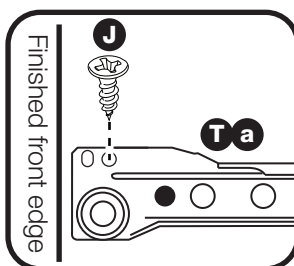
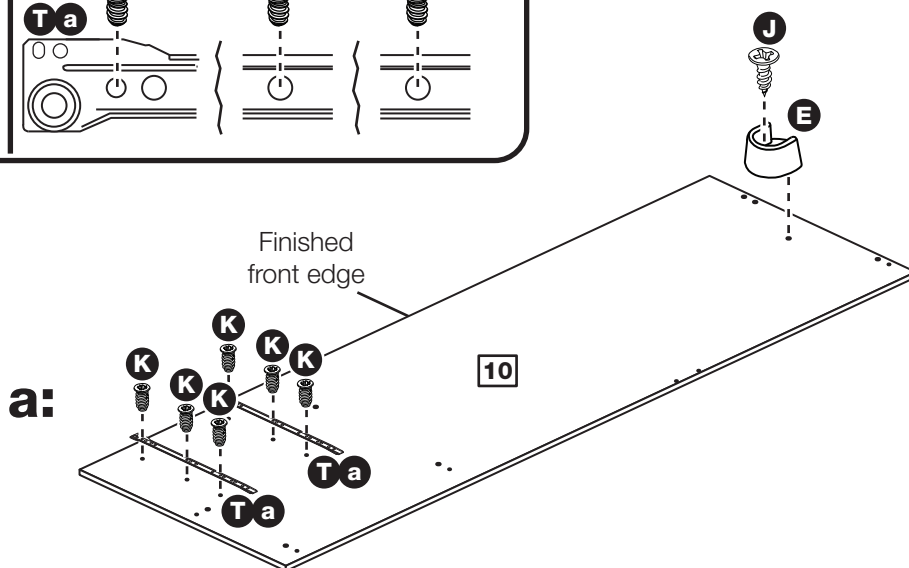
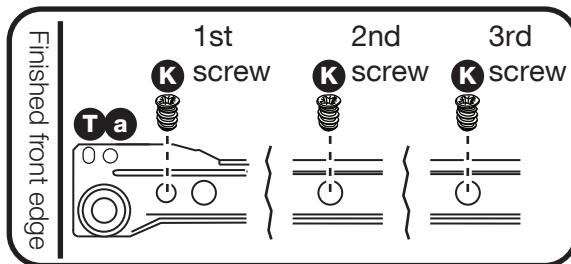

Assembly Instructions

Step 27

Fit the small divider

Push the small divider **16** onto the base **13**.

Use a screwdriver to tighten the 2 large locking nuts **C** fitted to the small divider **16**.

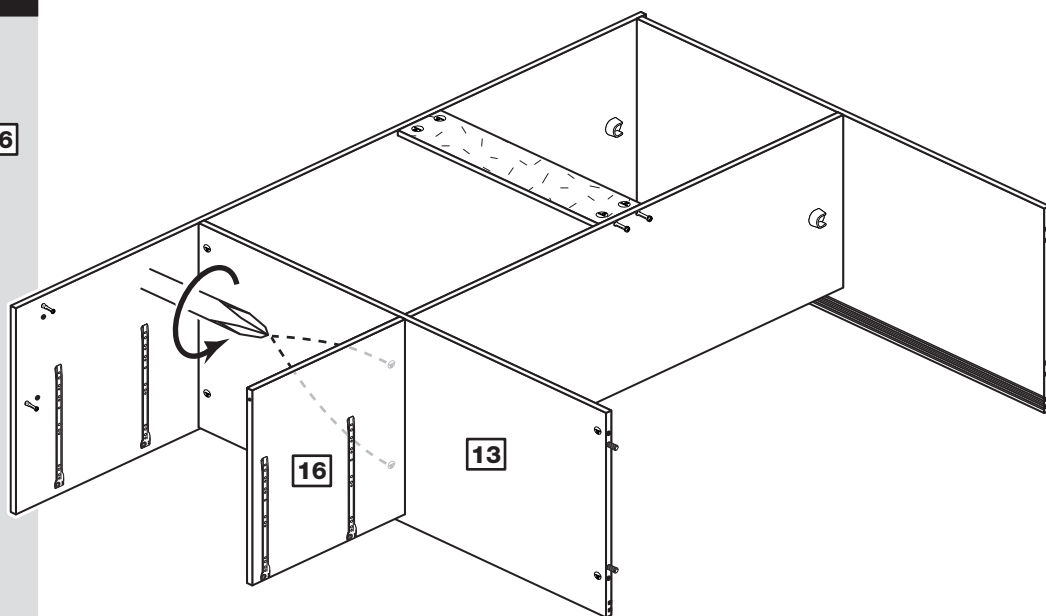

Step 28

Fit the 2 rails and the 2nd back rail

Push the 2 rails **14** onto the right side **11**.

Use a screwdriver to tighten the 2 large locking nuts **C** fitted to the rails **14**.

Push the back rail **15** onto the large divider **12**.

Use a screwdriver to tighten the 2 large locking nuts **C** fitted to the back rail **15**.

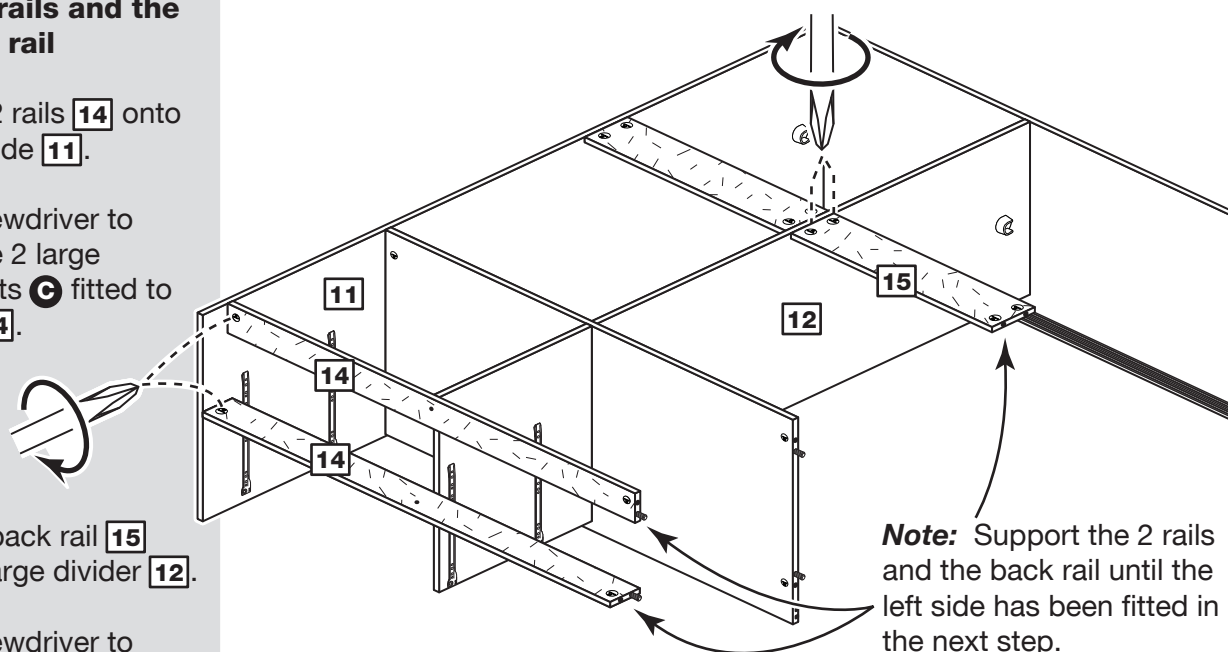

Note: Support the 2 rails and the back rail until the left side has been fitted in the next step.

Assembly Instructions

Step 29

Fit the left side

Push the left side **10** onto the assembly.

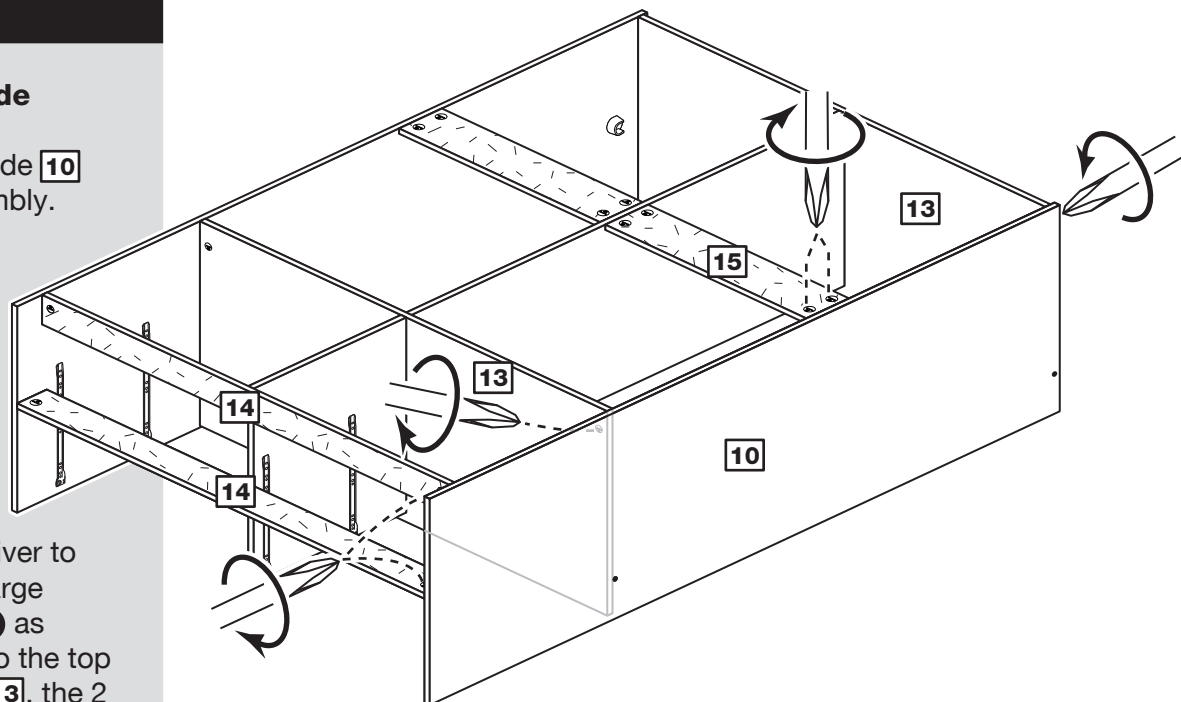

Use a screwdriver to tighten the 6 large locking nuts **C** as shown, fitted to the top **13**, the base **13**, the 2 rails **14** and the back rail **15**.

Step 30

Fit the mushroom head pins

a: Tap 2 mushroom head pins **a** into the holes on the outside of the left side **10** and into the top **13** and base **13**.

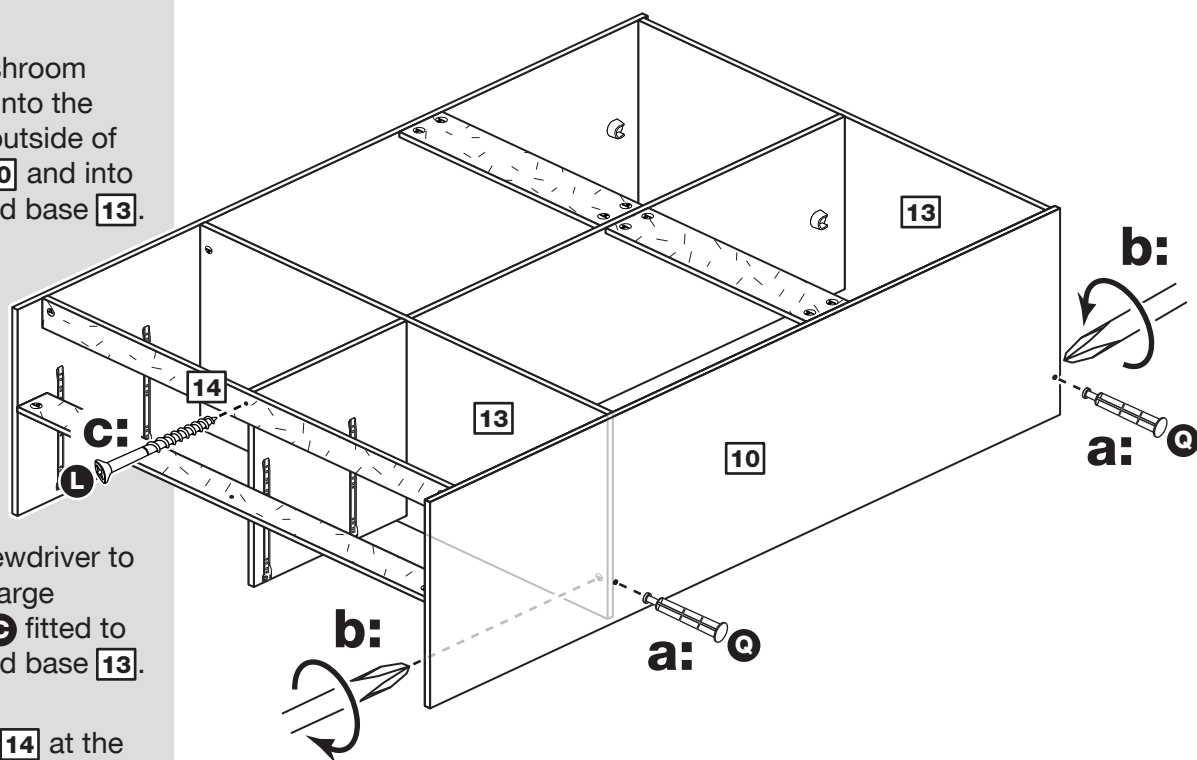

b: Use a screwdriver to tighten the 2 large locking nuts **C** fitted to the top **13** and base **13**.

c: Fit the rail **14** at the back of the unit to the small divider **16** using screw **L**.

Assembly Instructions

Step 31

Fit the back panels

a: Square up the unit by making sure that measurement **x:x equals y:y**.

Place the 2 backs **19** down onto the unit as shown.

Make sure that the 2 backs are pushed up tight against each other and that they meet over the back edge of the large divider.

b: Nail **F** around the outside edges
Fit the 6 plastic nails

Tap 2 plastic nails **Z** into the bottom edge of each of the sides **10** and **11** and rail **14**.

a: The measurement from top corner X to bottom corner X must be equal to the measurement from top corner Y to bottom corner Y

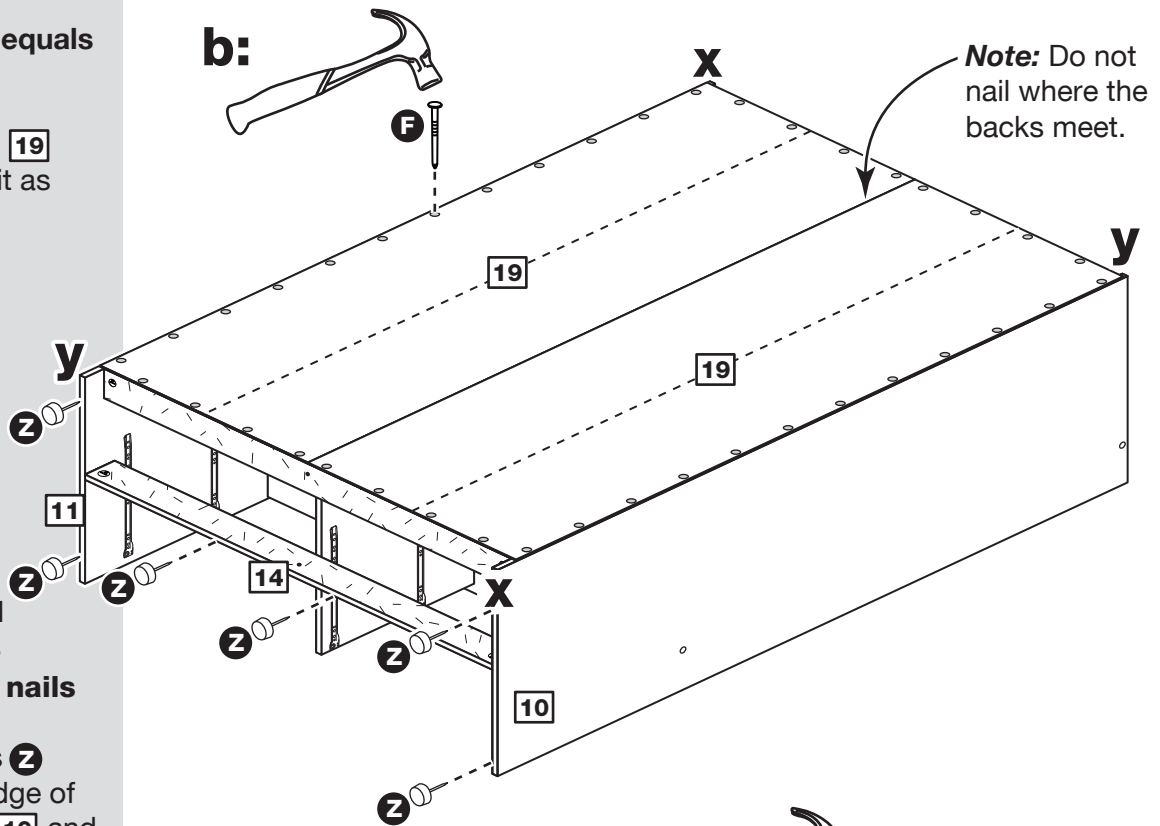

Step 32

Secure the backs

Tap the nail screws **V** through the back holders **W** and down between the 2 backs **19** into the back edge of the large divider.

Keep tapping the nail screws **V** in until the back holders **W** dig into the small and large back.

Stand the unit up for the next step.



Warning: The unit is heavy. Lift with care.

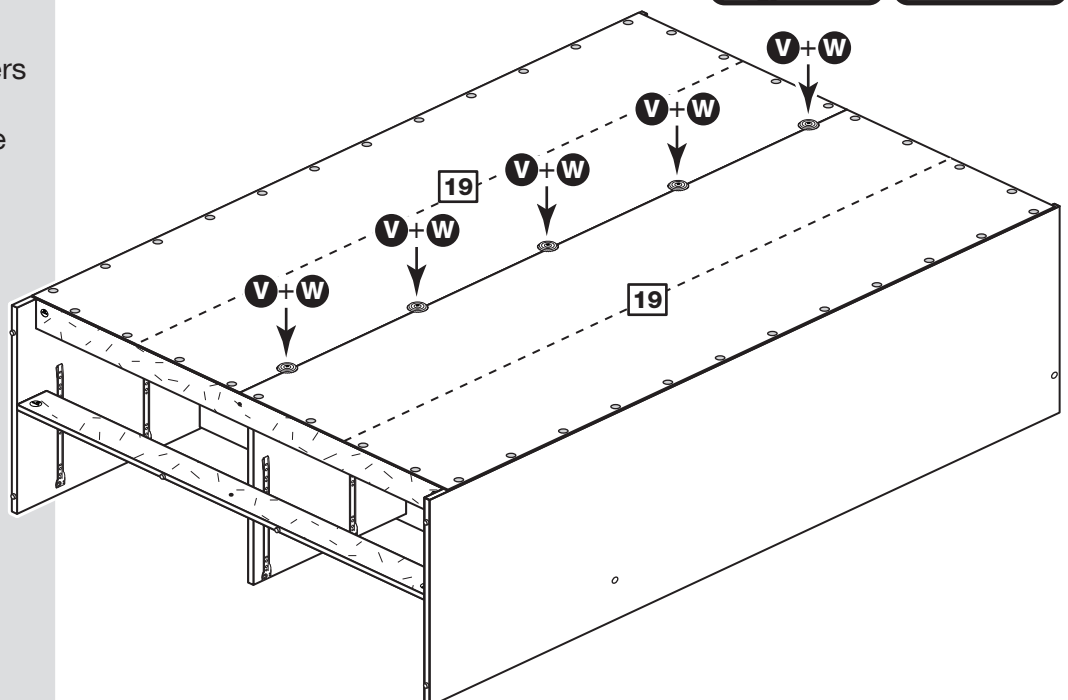
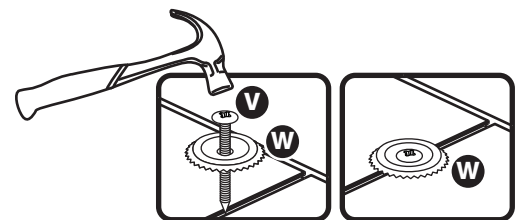

Assembly Instructions

Step 33

Fit the 2 hanging rails

Push the hanging rails **18** into the rail holders **E** fitted to the side panels and large divider.

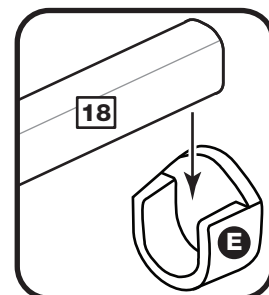
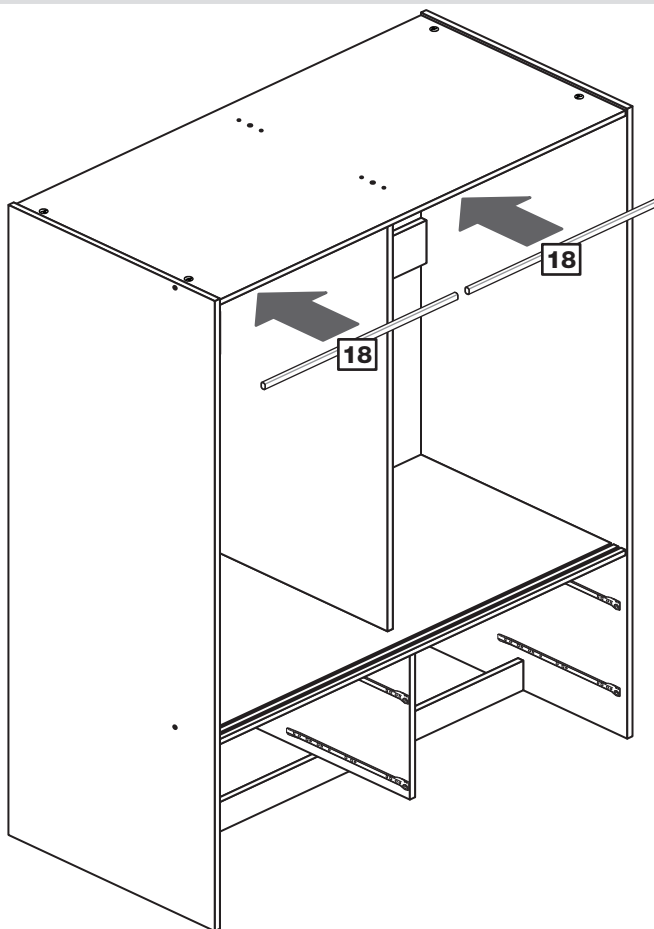

Step 34

Fit the 2 drawers

Slide the wheels of the runners fitted to the drawers, over the wheels of the runners fitted to the side panels and push the drawers into position.

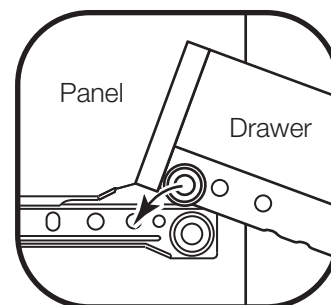
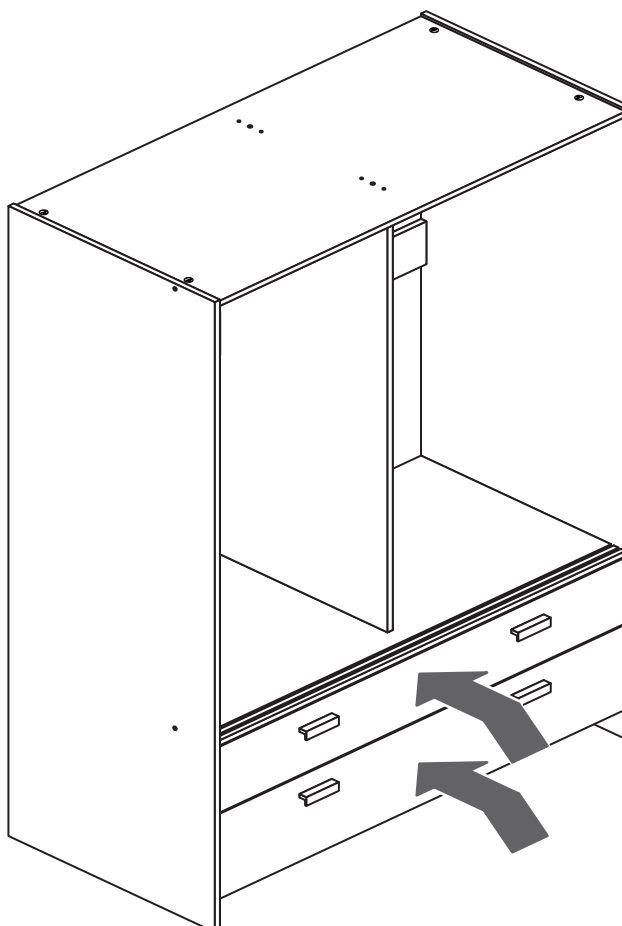

Assembly Instructions

Step 35

Prepare the right hand door

Important: Check that the holes are in the same place as the diagram.

Push 2 top glides **M** into 1 of the doors **17**.

Push 2 bottom glides **N** into the same door **17** and secure each one with 2 screws **J**.

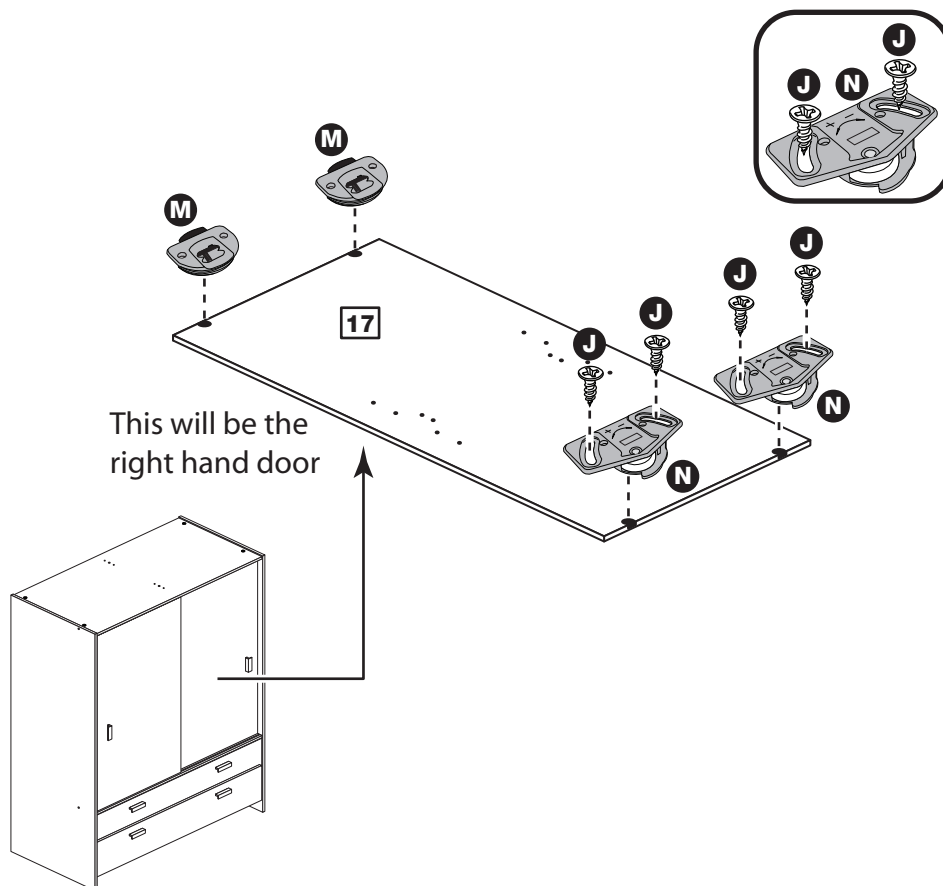

Step 36

Prepare the left hand door

Important: Check that the holes are in the same place as the diagram.

Fit the buffer bracket **R** onto the other door using 2 screws **J**.

Push 2 top glides **M** into the door **17**.

Push 2 bottom glides **N** into the door **17** and secure each one with 2 screws **J**.

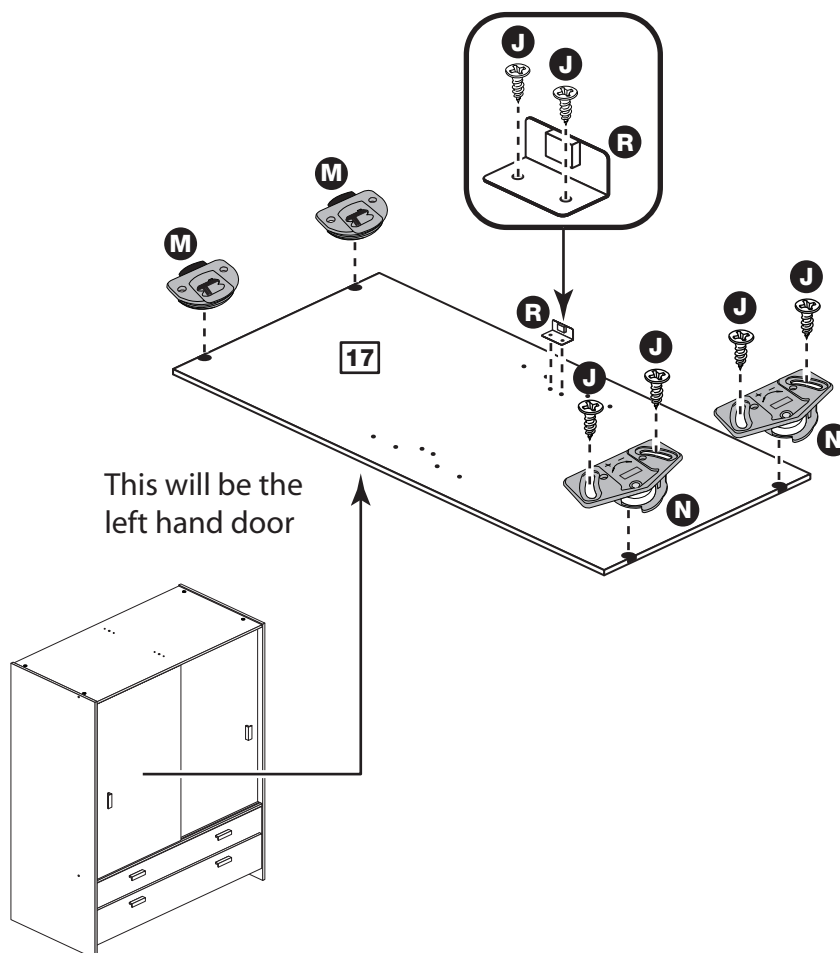

Assembly Instructions

Step 37

Drill 2 handle holes in each of the doors

Important: Please follow these instructions carefully.

Lay the 2 doors **17** down onto a smooth surface.

Check that the glides and holes are in the same place as the diagrams.

Note: We recommend the use of a small piece of waste wood, placed behind the holes while drilling, to reduce the possibility of any breakout.

Using the pilot holes in the rear face of the door, drill through the 2 holes indicated opposite, using a 2.5mm diameter drill.

Turn the door over and open out the 2.5mm holes that you have just drilled by drilling back through them with a 5mm drill.

IMPORTANT

Carefully choose which 2 holes you need to drill in each door

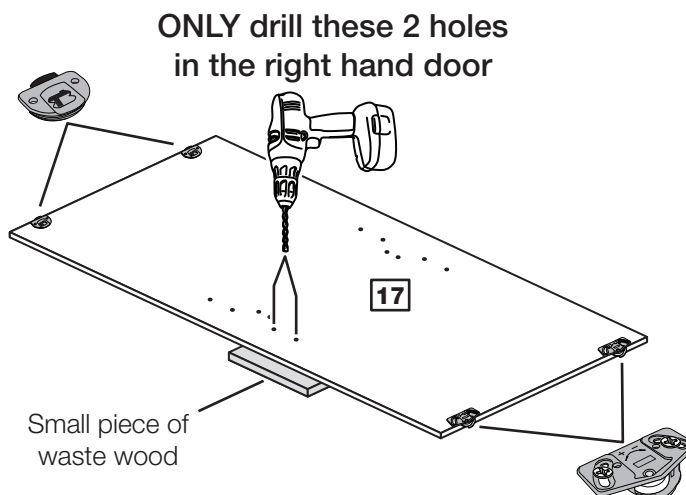
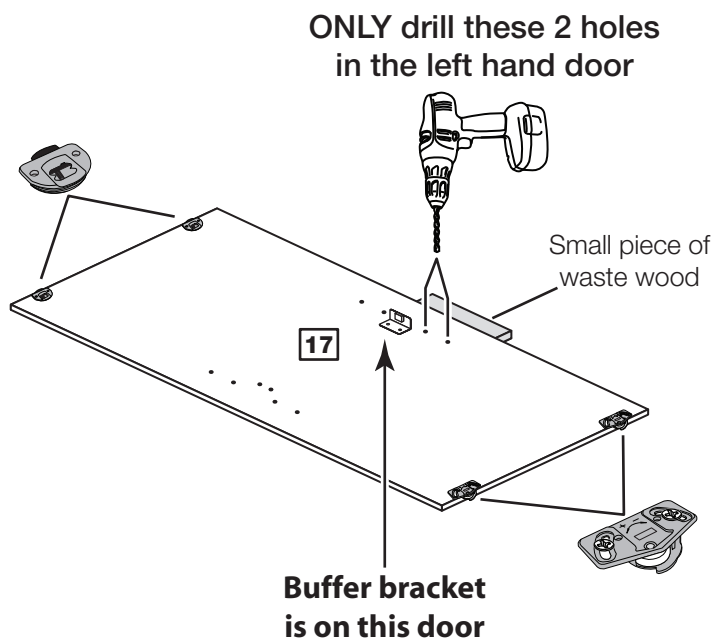

Assembly Instructions

Step 38

Fit the doors

a: With the top of the right hand door **17** leaning back at an angle, insert the bottom glides **N** into the rear track **O**.

Push the top of the right hand door **17** in and locate the top glides **M** into the rear track **O**.

b: With the top of the left hand door **17** leaning back at an angle, insert the bottom glides **N** into the front track **O**.

Push the top of the left hand door **17** in and locate the top glides **M** into the front track **O**.

Note: For more information about fitting the doors please refer to the relevant diagrams.

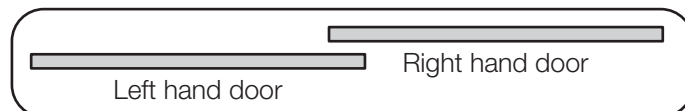
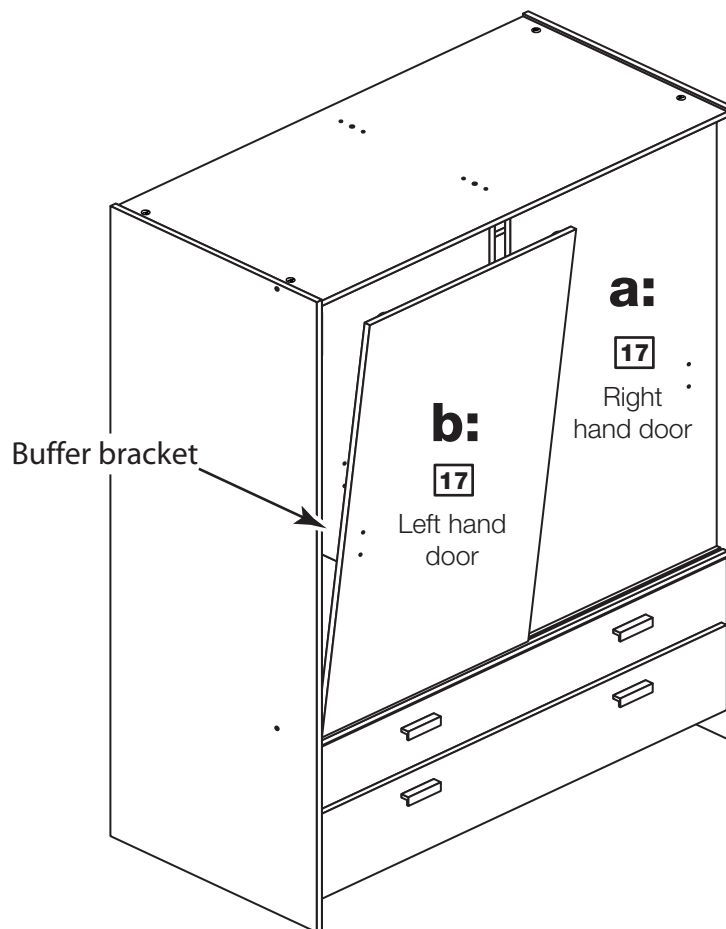

To fit the bottom of the Doors

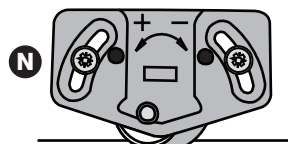

This lug fits into the groove in the track.

To fit the top of the Doors

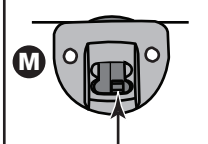

The switch in the top glides must be in this position prior to fitting the top of the Doors.

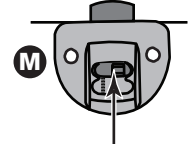

When the top of the Door is in position, press the switch to push lug into the groove of the track.

You may have been supplied with a top glide that differs slightly to the one shown. It may have a switch that just moves up and down and does not lock into position.

Assembly Instructions

Step 39

Adjust the doors if needed

If your doors are not running smoothly, please follow these instructions to adjust the bottom glides.

IF YOUR DOORS DO NOT RUN SMOOTHLY

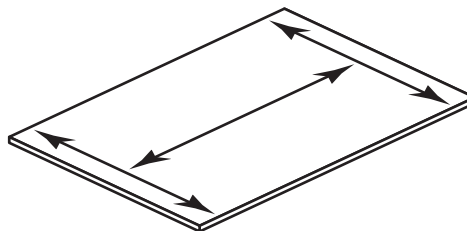

Before adjusting the doors, use a spirit level to check the base (or top) of the unit is level, front-to-back and side-to-side in the 3 positions shown.

Use suitable packing pieces (not supplied) to make the unit level BEFORE making any adjustment, as shown.

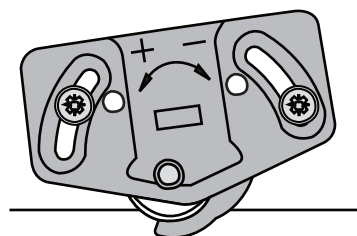

To raise the door, loosen the screws and swivel the glide towards the '+' arrow. Re-tighten the screws.

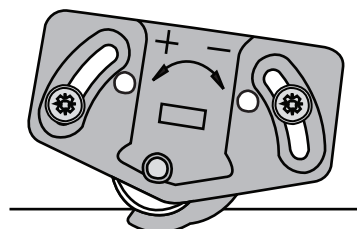

To lower the door, loosen the screws and swivel the glide towards the '-' arrow. Re-tighten the screws.

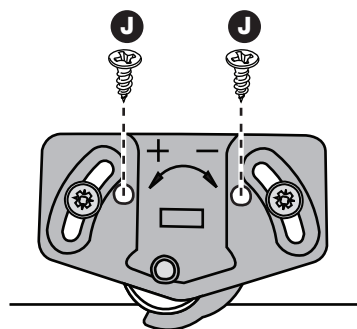

Once the doors have been adjusted and are running smoothly, use 2 screws **J** to hold each of the bottom glides in position.

Assembly Instructions

Step 40

Attach the handles

Attach a handle **U** to each of the doors **17** using 2 screws **H**.

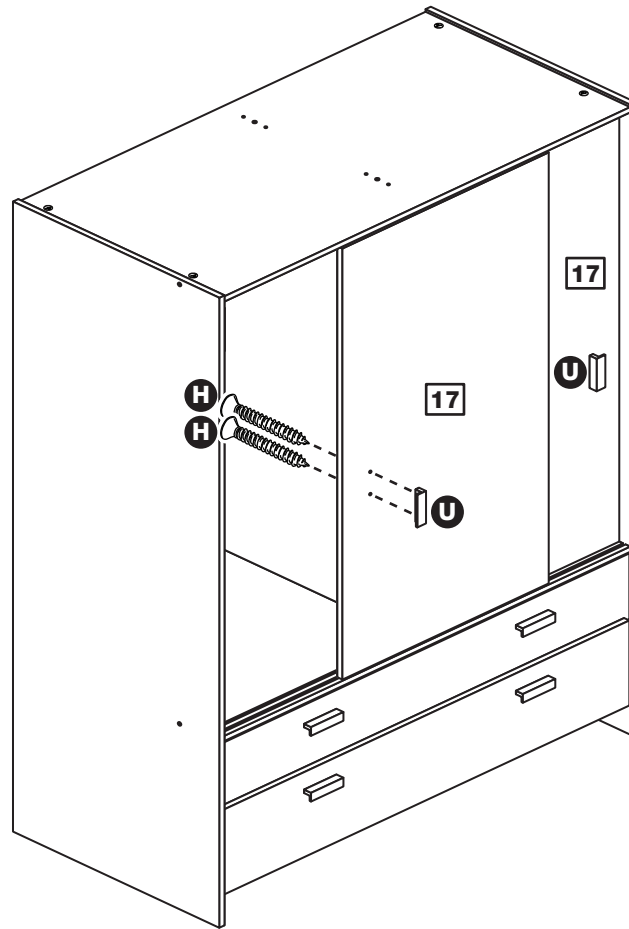

Assembly Instructions

Step 41

Fit the bracket

To prevent possible overbalancing, we recommend that this unit is secured to a suitable wall by use of the bracket **Y** fitted to the top of the unit.

Fixings are not supplied, as they will need to suit the wall type and the length of screw will depend on the distance from the back of the unit to the wall.

Fix the bracket **Y** loosely onto the top of the unit using screw **I** and mark the wall for the wall fixing.

Swivel the bracket **Y** away from the wall and drill a hole in the wall using a suitable drill bit and fit your wall fixing.

Swivel the bracket **Y** back and fix the bracket to the wall, then tighten Screw **I**.

Note: Take care when drilling the wall that you do not drill into any pipes, wires etc. If in doubt, consult an expert.



Warning: The unit is heavy. Lift with care.

Assembly is complete

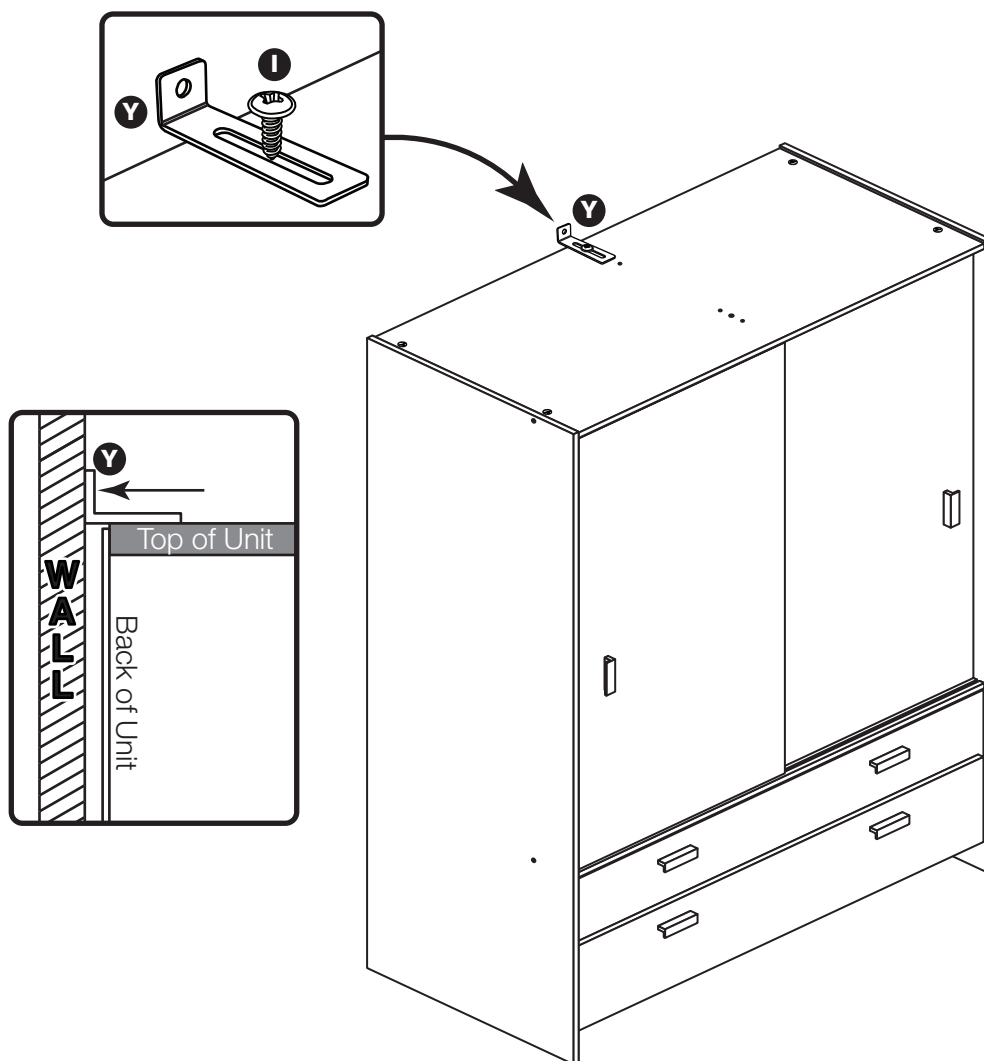

If you need help or have damaged or missing parts, call the Customer Helpline: 08456 400800 and quote the reference numbers on the component pages.

Argos Ltd, 489-499 Avebury Boulevard, Central Milton Keynes, MK9 2NW