

# Malibu - Single Bedside

Assembly Instructions - Please keep for future reference

257/3717

268/8303

257/2749

267/6793

259/5726

346/0142

345/8075

362/4713

343/9829

346/6005

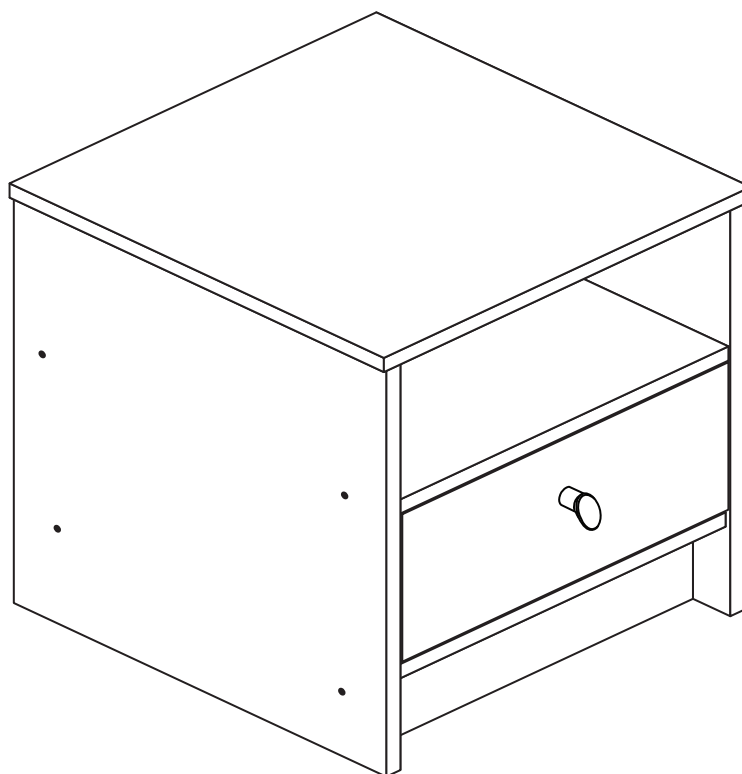

## Dimensions

Width - 39cm

Depth - 40cm

Height - 45cm



**MADE IN  
BRITAIN**

**Important** - Please read these instructions fully before starting assembly

If you need help or have damaged or missing parts, call the **Customer Helpline: 08456 400800**



# Safety and Care Advice

**Important - Please read these instructions fully before starting assembly**

- **Warning:** This unit weighs approximately 10kgs. Please lift with care.

- Check you have all the components and tools listed on pages 2 and 3.

- Remove all fittings from the plastic bags and separate them into their groups.

- Keep children and animals away from the work area, small parts could choke if swallowed.

- Make sure you have enough space to layout the parts before starting.

- Do not stand or put weight on the product, this could cause damage.

- Assemble the item as close to its final position (in the same room) as possible.

- Assemble on a soft level surface to avoid damaging the unit or your floor (use opened out unit carton).



- We do not recommend the use of power drill/drivers **for inserting screws**, as this could damage the unit. Only use hand screwdrivers.

- **Safety note:** If there is any chance of this unit being pulled over by children etc. it is recommended that the unit is secured to a wall using suitable fixings (not supplied).

- Dispose of all packaging carefully and responsibly.

## Care and maintenance

- Only clean using a damp cloth and mild detergent, do not use bleach or abrasive cleaners.

- From time to time check that there are no loose screws on this unit.

- This product should not be discarded with household waste. Take to your local authority waste disposal centre.

**Note:** If required the next page can be cut out and used as reference throughout the assembly. Keep this page with these instructions for future reference.

# Components - Panels

If you have damaged or missing components, call the **Customer Helpline: 08456 400800** quoting the reference numbers below

Please check you have all the panels listed below

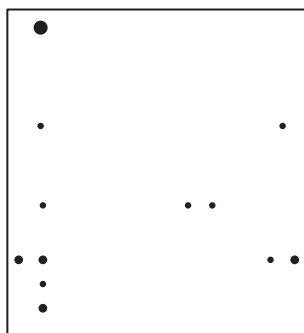

**1** Left Side (D2848A)  
(431 x 394mm)

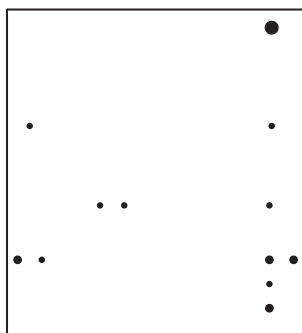

**2** Right Side (D2849A)  
(431 x 394mm)

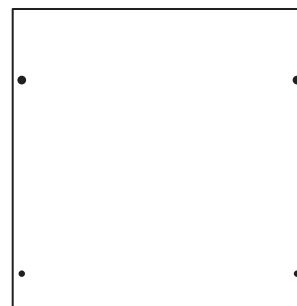

**3** Top (D2823A)  
(388 x 396mm)



**4** Left Drawer Side (W370-124LH)  
(370 x 124mm)



**5** Right Drawer Side (W370-124RH)  
(370 x 124mm)



**6** Drawer Back (W317-124BCK)  
(317 x 124mm)

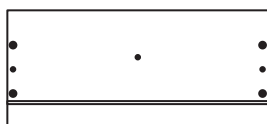

**7** Drawer Front (D2824A)  
(345 x 156mm)

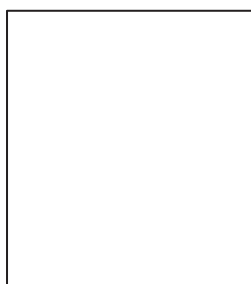

**8** Drawer Base (T328-367)  
(328 x 367mm)

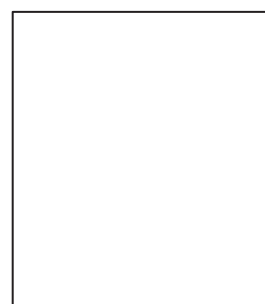

**9** Shelf (D2862A)  
(349 x 392mm)



**10** Plinth (D2825A)  
(349 x 92mm)



**11** Rail (D2826A)  
(349 x 72mm)

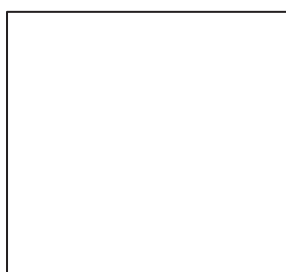

**13** Back (X373-351)  
(373 x 351mm)

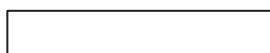

**12** Back Rail (D2836A)  
(349 x 60mm)











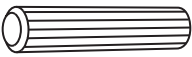
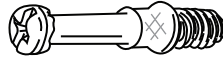

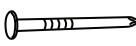

# Components - Fittings

If you have damaged or missing components, call the **Customer Helpline: 08456 400800** quoting the reference numbers below

Please check you have all the fittings listed below

**Note:** The quantities below are the correct amount to complete the assembly. In some cases more fittings may be supplied than are required.

<p><b>A</b> </p> <p>Wooden dowel (F22) x 10</p>	<p><b>B</b> </p> <p>Metal dowel (F901) x 4</p>	<p><b>C</b> </p> <p>Plastic Nail (F91) x 4</p>
<p><b>D</b> </p> <p>Nail (F51) x 10</p>	<p><b>E</b> </p> <p>Large locking nut (F900) x 2</p>	<p><b>F</b> </p> <p>Small locking nut (F3) x 2</p>
<p><b>G</b> </p> <p>40mm Screw (F910) x 8</p>	<p><b>H</b> </p> <p>25mm Screw (F50) x 1</p>	<p><b>I</b> </p> <p>Knock-in Peg (F171WH) x 4</p>
<p><b>J</b> </p> <p>Drawer runner (F1004) x 2</p>		<p><b>K</b> </p> <p>Handle (F631) x 1</p>
<p><b>L</b> </p> <p>9mm Screw (F73) x 4</p>	<p><b>M</b> </p> <p>9mm Screw (F74) x 2</p>	<p><b>N</b> </p> <p>Wedgefix (F639) x 2</p>

## Tools required

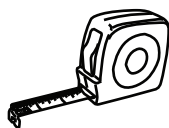

Rule



Cross-head screwdriver



Scissors



Hammer



Eye protection  
(when using a hammer or drill)

Ruler - Use this ruler to help correctly identify the screws

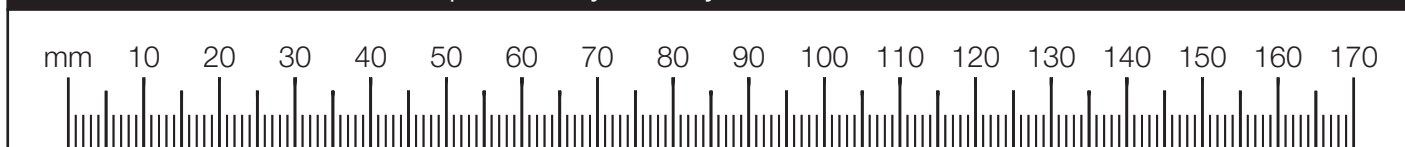

# Assembly Instructions

If you have damaged or missing components, call the  
**Customer Helpline: 08456 400800** quoting the reference  
numbers below

## Step 1

### Prepare the drawer front

Screw 2 metal dowels **B** into the drawer front **7**.

**Note:** Tighten the metal dowels up fully against the panels.

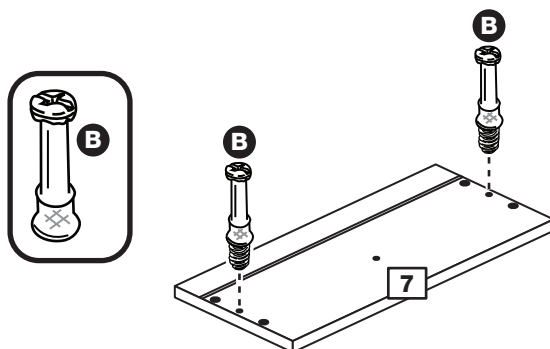

## Step 2

### Prepare the drawer sides

Insert a small locking nut **F** into the hole shown on the left drawer side **4** and the right drawer side **5**.

**Note:** The arrow on the locking nut **must** point towards the hole in the edge of the panel.

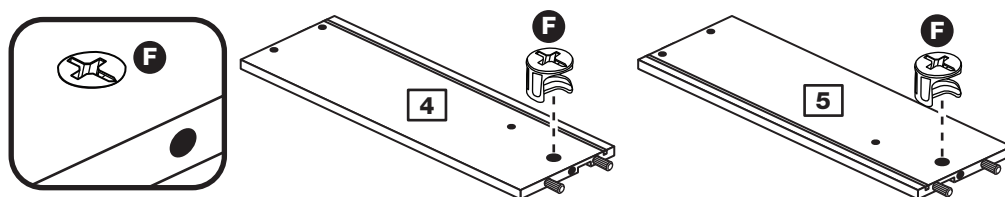

## Step 3

### Attach the drawer sides to the drawer front

Push the left drawer sides **4** and right drawer sides **5** onto the back of the drawer front **7**.

Turn the small locking nuts **F** on the left drawer side **4** and right drawer side **5**.

**Note:** Turn the locking nuts **F** clockwise to secure panels - more than 1/2 a turn.

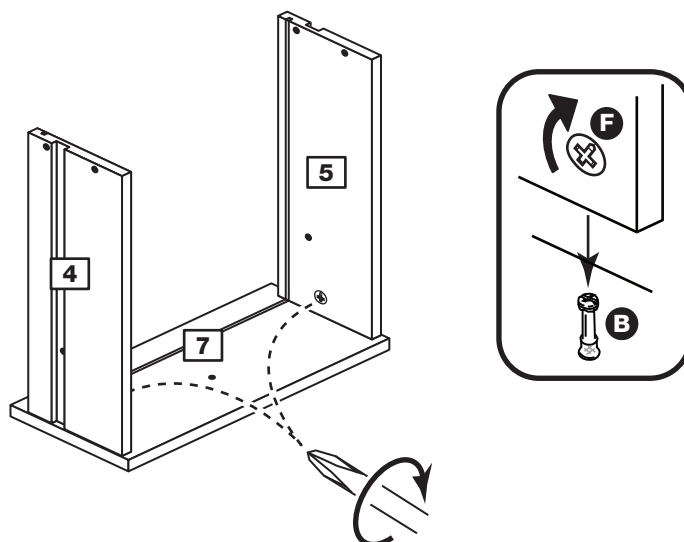

# Assembly Instructions

## Step 4

### Fit the drawer base

Slide the drawer base **8** down the grooves in the drawer sides **4** and **5** and down into the groove in the drawer front **7**.

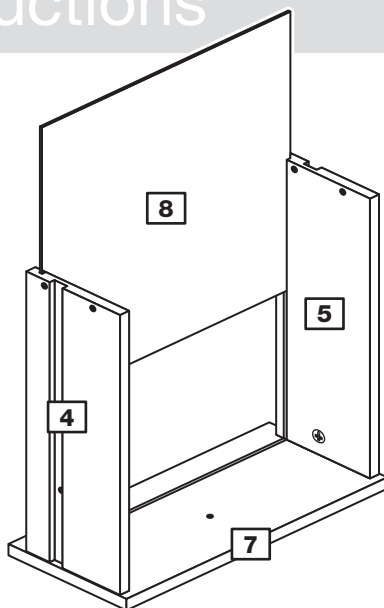

## Step 5

### Fit the drawer back

Fit the drawer back **6** between the drawer sides **4** and **5**. Make sure that the drawer base **8** fits into the groove in the drawer back **6**.

Hold the drawer back **6** in position and tap the knock-in pegs **I** through the holes in the drawer sides **4** and **5**.

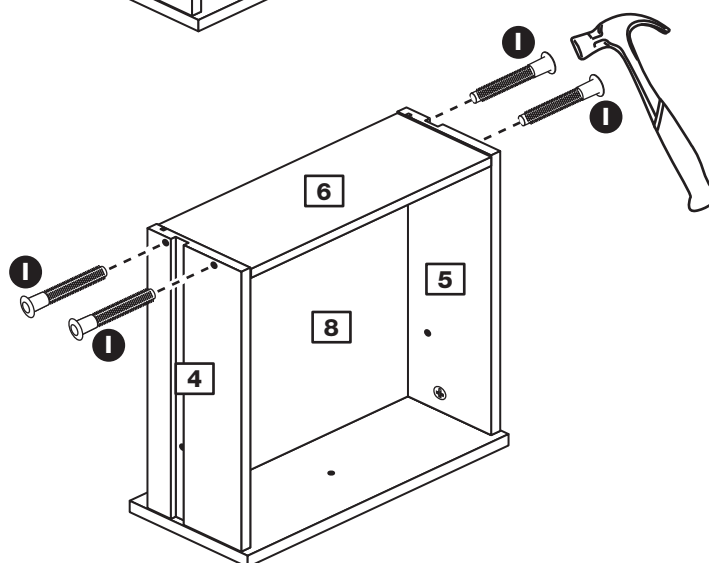

## Step 6

### Attach the handle

Attach the handle **K** to the drawer front **7** using screw **H**.

**Note: Do not overtighten the screw.**

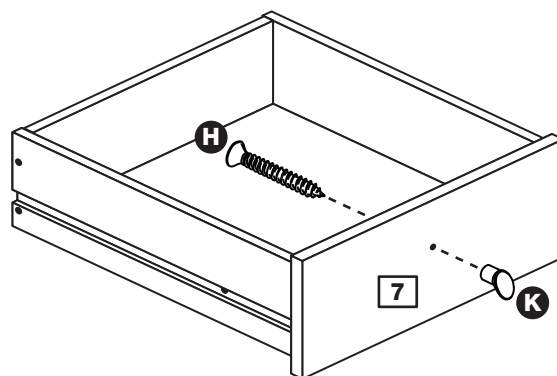

## Step 7

### Fit the wedgifixes

Turn the drawer assembly over and slide 2 wedgifixes **N** into the front and back grooves, as shown, and tighten up the screws.

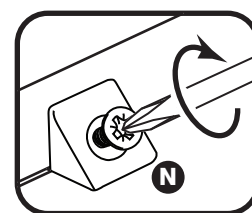
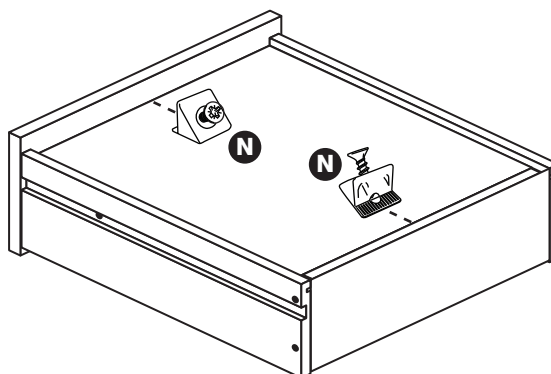

# Assembly Instructions

## Step 8

### Prepare the left side

**a:** Place a runner **J** on the left side **1** as shown. Slide back the top of runner and use the 2nd hole from the front to fit the 1st screw **L**.

**b:** Slide the runner **J** back the other way and fit the 2nd screw **L** into the corresponding hole in the left side **1**.

Insert a large locking nut **E** into the left side **1**.

**Note:** The arrow on the locking nuts **must** point towards the hole in the edge of the panel.

Tap a wooden dowel **A** into the left side **1**.

**Note:** Wooden dowels **must not** stick out from the edge by more than 10mm or they may damage other panels.

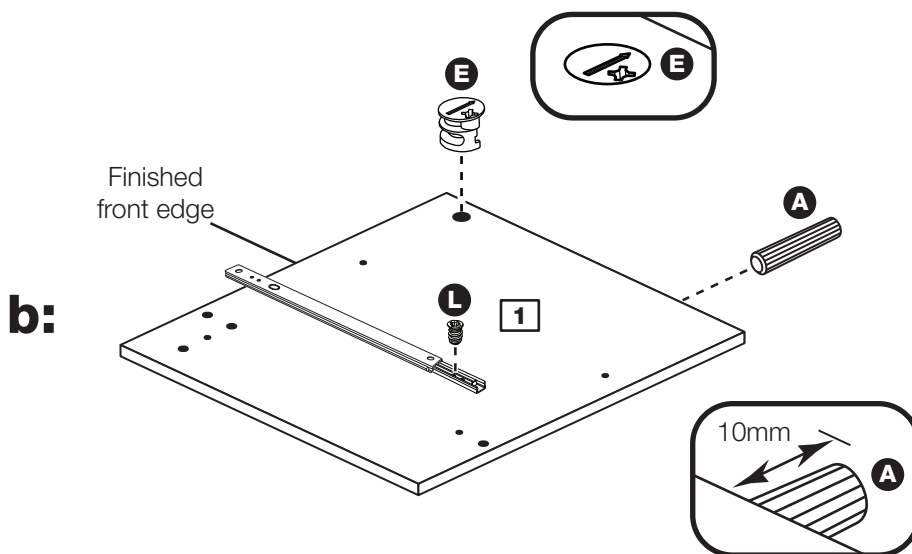
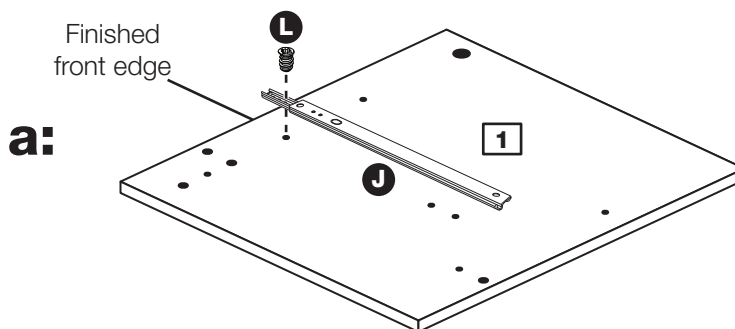
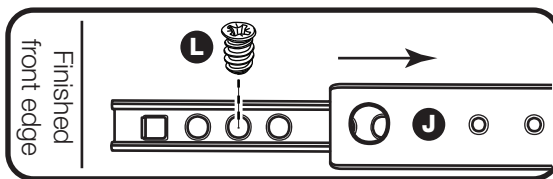

# Assembly Instructions

## Step 9

### Prepare the right side

**a:** Place a runner **J** on the right side **2** as shown. Slide back the top of runner and use the 2nd hole from the front to fit the 1st screw **L**.

**b:** Slide the runner **J** back the other way and fit the 2nd screw **L** into the corresponding hole in the right side **2**.

Insert a large locking nut **E** into the right side **2**.

**Note:** The arrow on the locking nuts **must** point towards the hole in the edge of the panel.

Tap a wooden dowel **A** into the right side **2**.

**Note:** Wooden dowels **must not** stick out from the edge by more than 10mm or they may damage other panels.

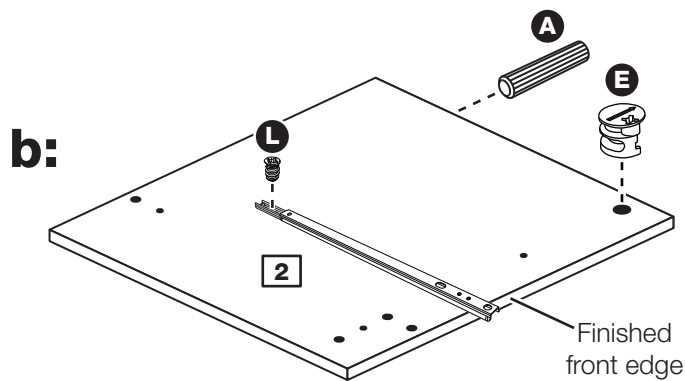
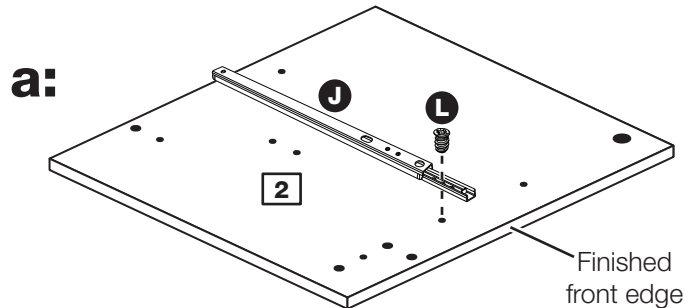
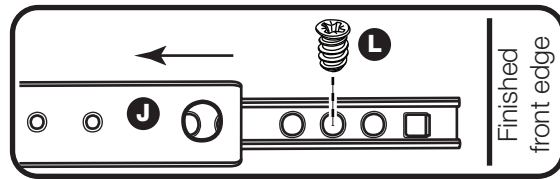

## Step 10

### Prepare the plinth, rail and back rail

**a:** Tap 2 wooden dowels **A** into the plinth **10**.

**b:** Tap 4 wooden dowels **A** into the rail **11**.

**a:** Tap 2 wooden dowels **A** into the back rail **12**.

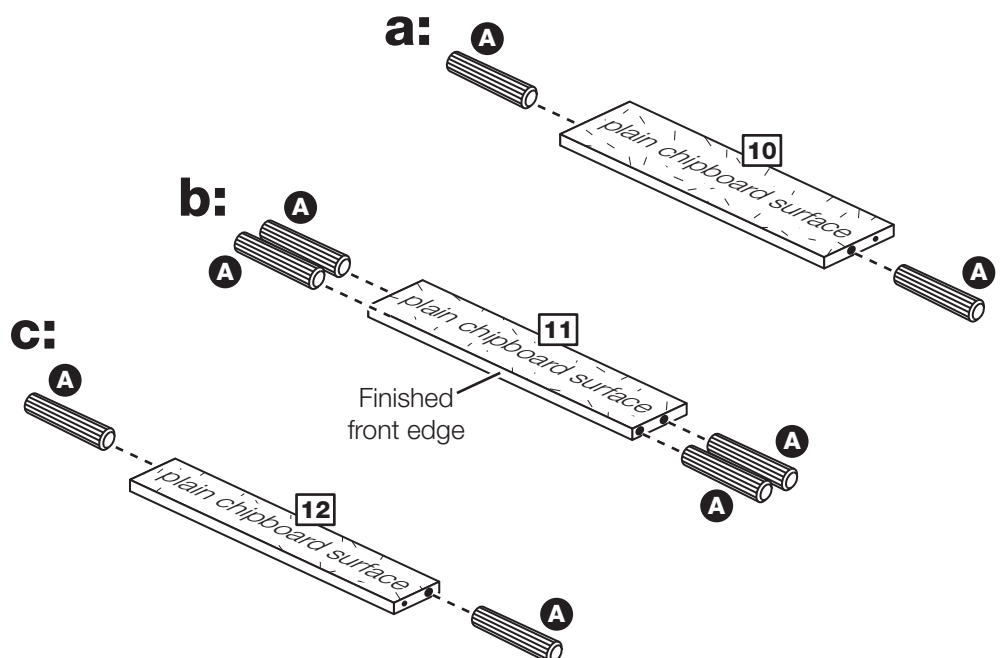



# Assembly Instructions

## Step 11

### Fit the shelf and the rail to the right side

Position the shelf **9** against the right side **2** as shown and secure with 2 screws **G**.

Push the rail **11** onto the right side **2**.

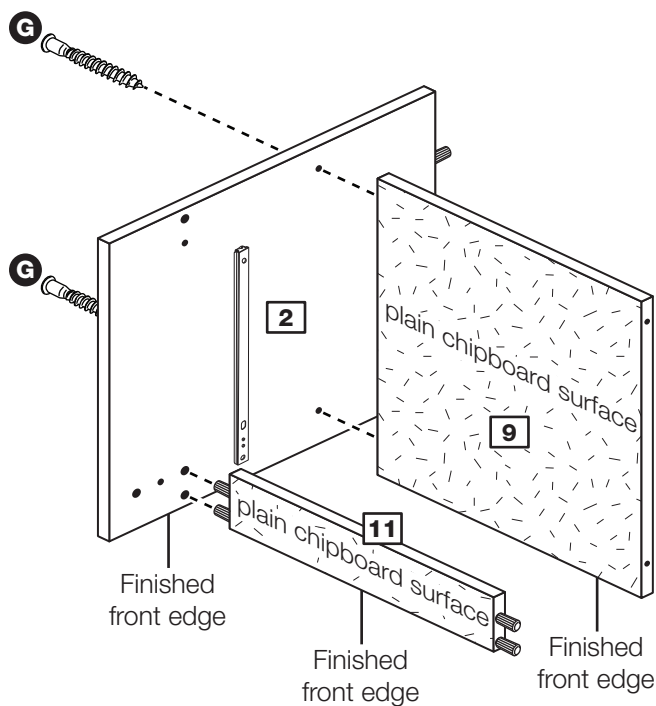

## Step 12

### Fit the plinth and back rail to the right side

Push the plinth **10** onto the right side **2** and secure it with screw **G**.

Push the back rail **12** onto the right side **2** and secure it with screw **G**.

**Note:** Support the back rail until the left side has been fitted in the next step.

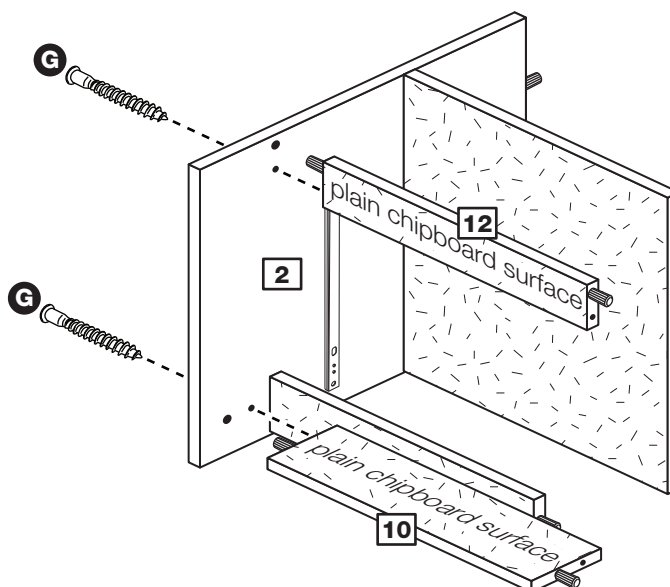

# Assembly Instructions

## Step 13

### Fit the left side

Push the left side **1** onto the unit and secure it with 4 screws **G**.

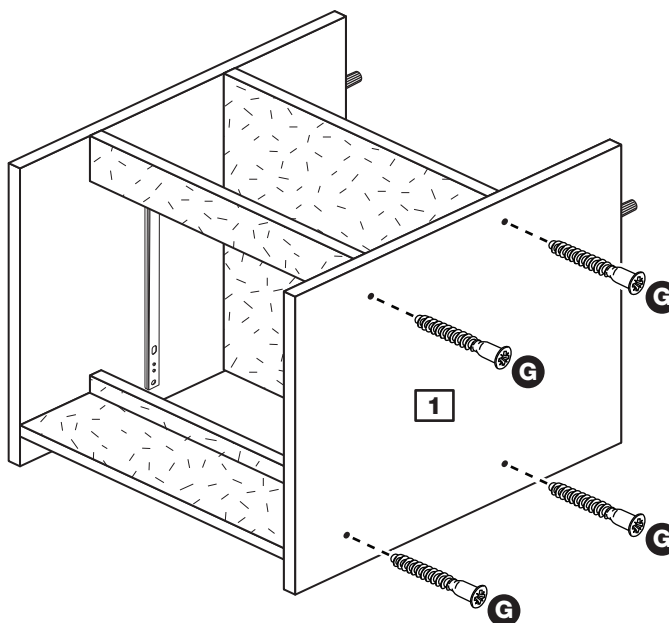

## Step 14

### Prepare the top

Screw 2 metal dowels **B** into holes shown on the underside of the top **3**.

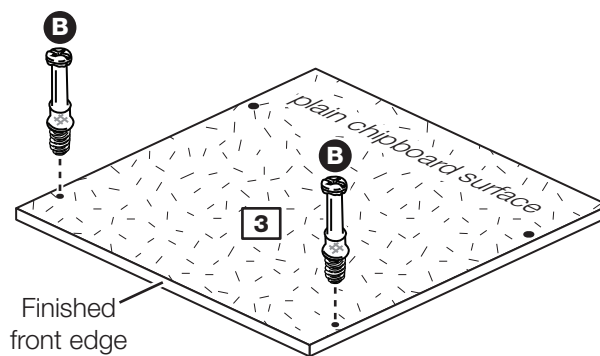

# Assembly Instructions

## Step 15

### Attach the top

Push the top **3** onto the side panels **1** and **2**.

Use a screwdriver to tighten the large locking nut **E** fitted to each side.

**Note:** Turn the large locking nut as far as it will go - more than 1/2 a turn.

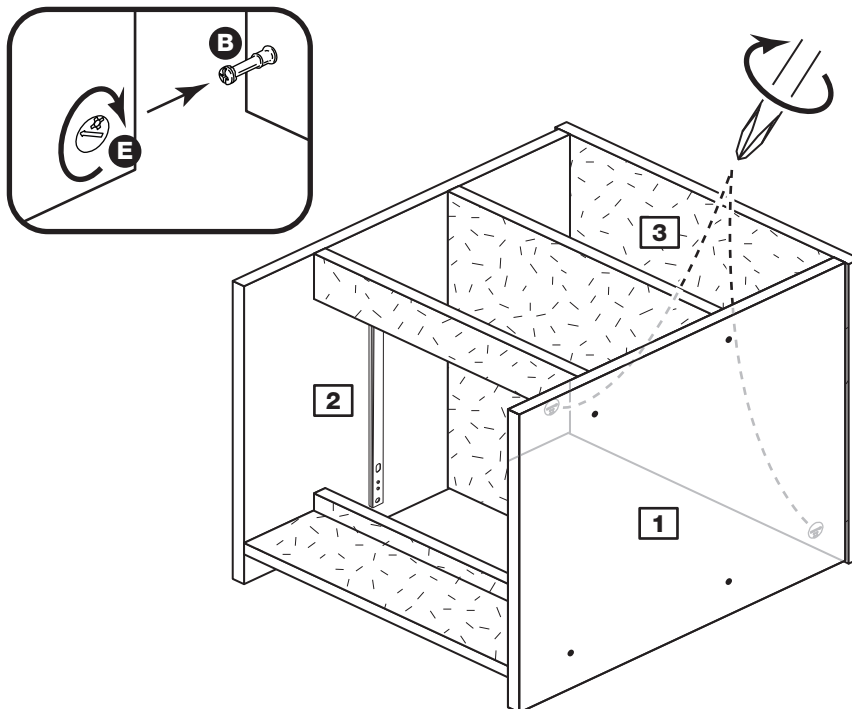

## Step 16

### Fit the back

**a:** Square up the unit by making sure that measurement **x to x** equals **y to y**.

**b:** Place the back **13** onto the unit.

Nail **D** around the outside edges of the back **13**.

**Note:** Nails should be spaced about 150mm apart.

**a:** The measurement from top corner X to bottom corner X must be equal to the measurement from top corner Y to bottom corner Y

**b:**

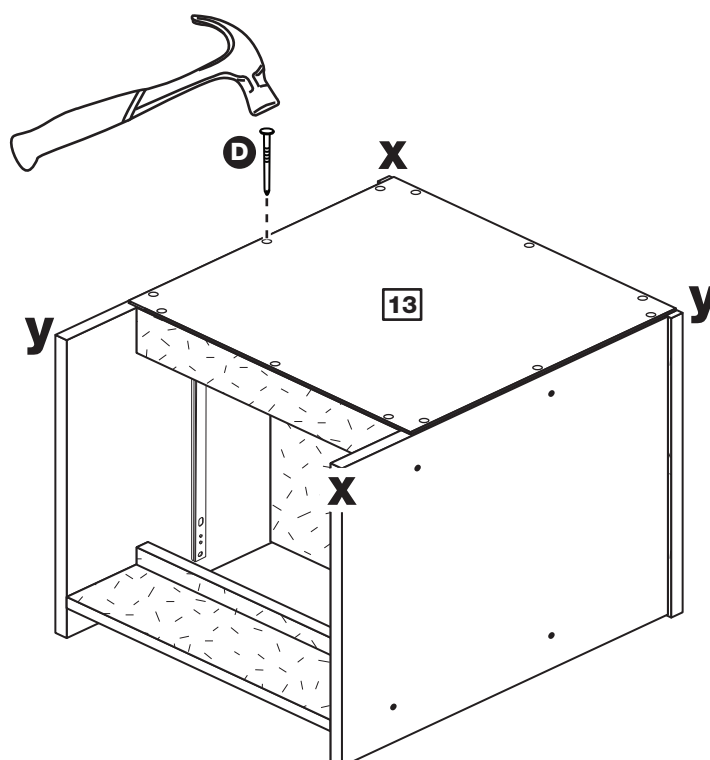

# Assembly Instructions

## Step 17

### Fit the 4 plastic nails

Tap 2 plastic nails **C** into the bottom edge of each side **1** and **2** as shown.

**Stand the unit up for the next step.**

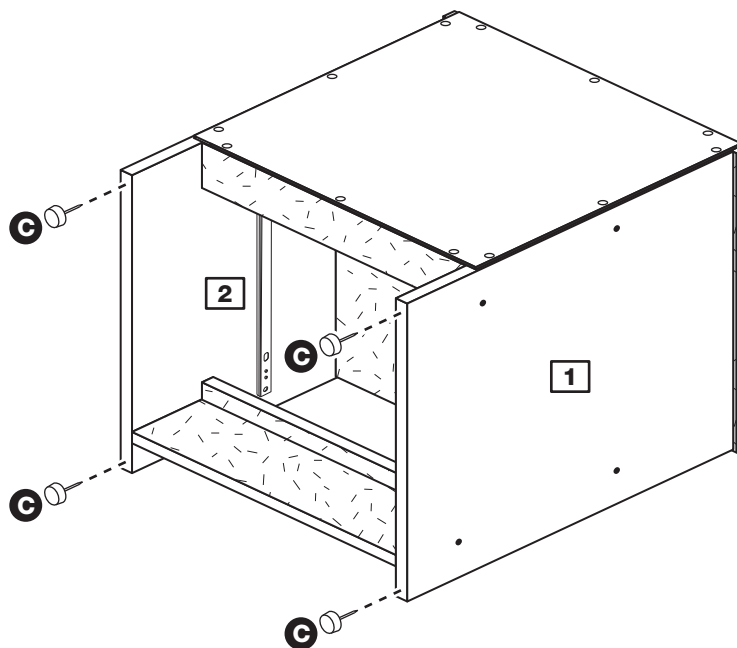

## Step 18

### Fit the drawers

Slide both the runners **J** forward and locate the drawer sides **4** and **5** between them, lining up the holes in the drawer wrap with the 2nd 'threaded' holes in the runners **J**.

Working from the inside of the drawer, insert 2 screws **M** through the drawer sides and out into the 2nd threaded hole in the runner.

**Note:** Do not overtighten the screws.

If they catch on the runner you may need to loosen them slightly.

**Assembly is complete**

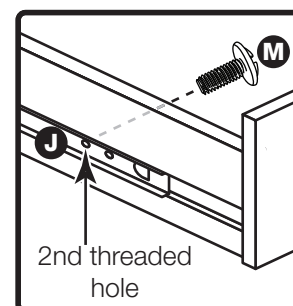
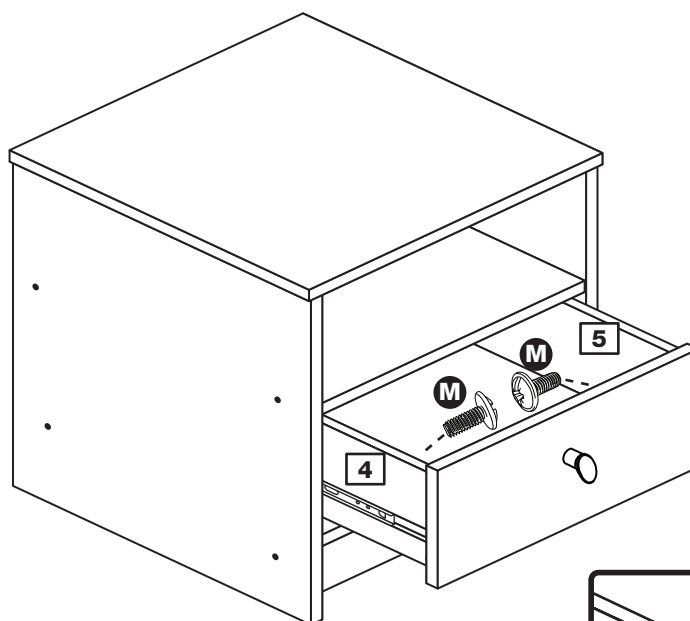

If you need help or have damaged or missing parts, call the Customer Helpline: 08456 400800 and quote the reference numbers on the component pages.

Argos Ltd, 489-499 Avebury Boulevard, Central Milton Keynes, MK9 2NW