

Knightsbridge Oak Console Table

Assembly Instructions - Please keep for future reference

259/3034

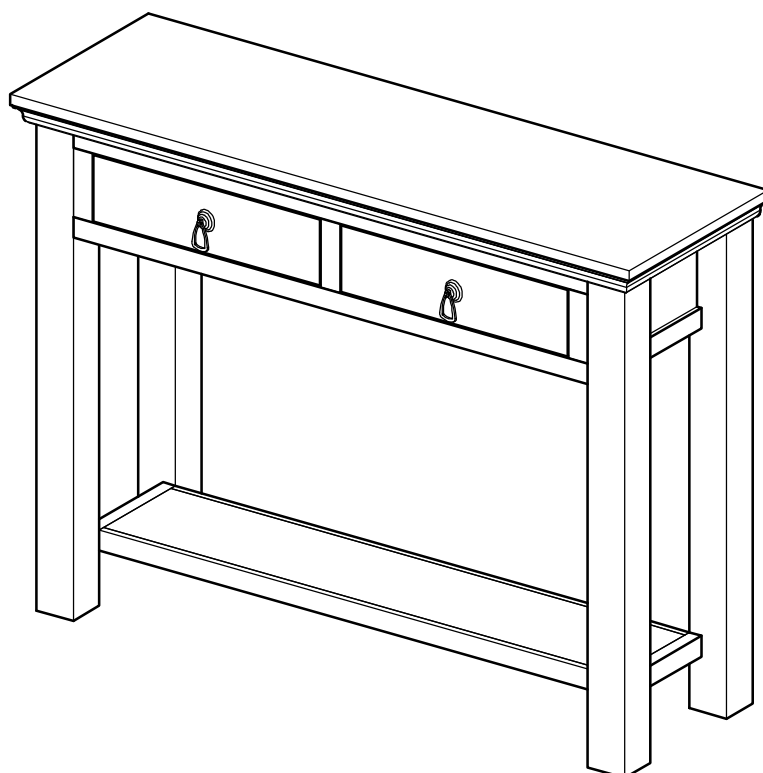

Dimensions

Width - 100cm
Depth - 32cm
Height - 75cm

Important - Please read these instructions fully before starting assembly

If you need help or have damaged or missing parts, call the **Customer Helpline: 0845 640 0800**



Safety and Care Advice

Important - Please read these instructions fully before starting assembly

- Check you have all the components and tools listed on pages 2 and 3.
- Remove all fittings from the plastic bags and separate them into their groups.
- Keep children and animals away from the work area, small parts could choke if swallowed.
- Make sure you have enough space to layout the parts before starting.

- Do not stand or put weight on this product during assembly, this could cause damage.
- Assemble the item as close to its final position (in the same room) as possible.
- Assemble on a soft level surface to avoid damaging the unit or your floor.
- Parts of the assembly will be easier with 2 people.

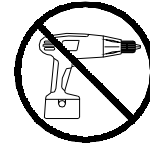

• We do not recommend the use of power drill/drivers **for inserting screws**, as this could damage the unit. Only use hand screwdrivers.

- Dispose of all packaging carefully and responsibly.

Care and maintenance

- Only clean using a damp cloth and mild detergent, do not use bleach or abrasive cleaners.
- From time to time check that there are no loose screws on this unit.
- This product should not be discarded with household waste. Take to your local authority waste disposal centre.

Components - Panels

If you have damaged or missing components, call the **Customer Helpline: 0845 640 0800**

Please check you have all the panels listed below

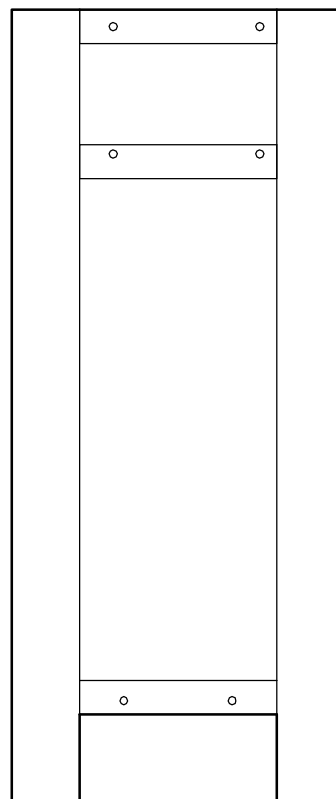
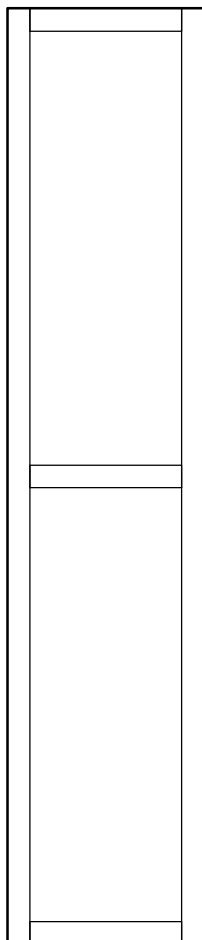
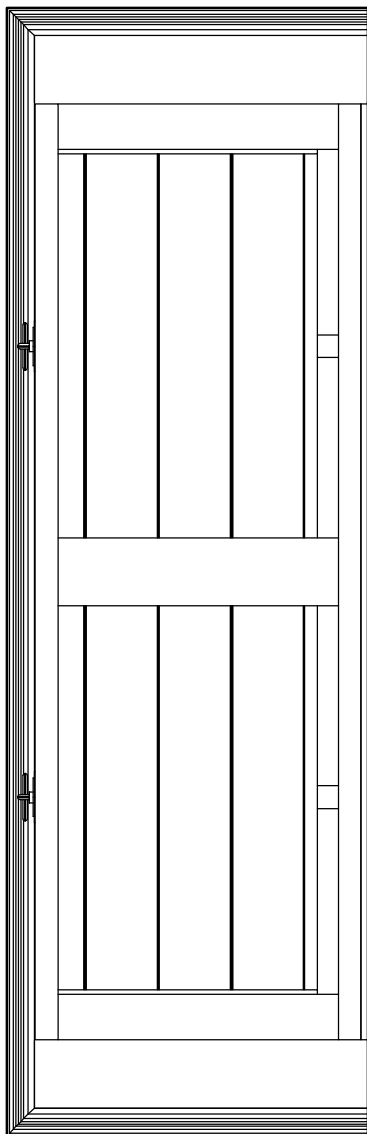

1 Top frame x 1 (100 x 32 cm)

2 Shelf frame x 1 (83 x 17.5cm)

3 Leg frame x 2 (71 x 29.5cm)



Components - Fittings

Please check you have all the fittings listed below

Note: The quantities below are the correct amount to complete the assembly. In some cases more fittings may be supplied than are required.



M6x35mm Bolt x 8

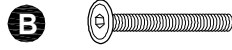

M6x55mm Bolt x 4



Allen key x 1

Tools required

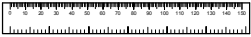

Ruler/tape
measure

Ruler - Use this ruler to help correctly identify the screws



Assembly Instructions

Step 1

Removing the drawers.

Pull the drawer out until it is fully extended. Turn the stopper to unlock. Pull the drawer out of the top frame **1**. Place the drawer aside.

Repeat with the other drawer.

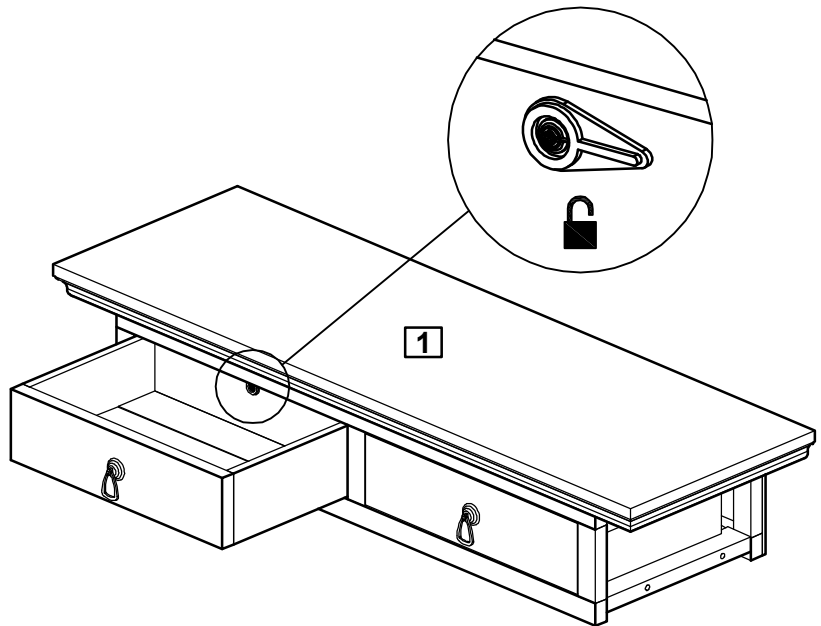

Step 2

Attaching the leg frames.

With the help of another person, turn the top frame **1** over carefully. Attach leg frames **3** to the sides of the top frame **1** using bolts **A**. Tighten with allen key **C**.

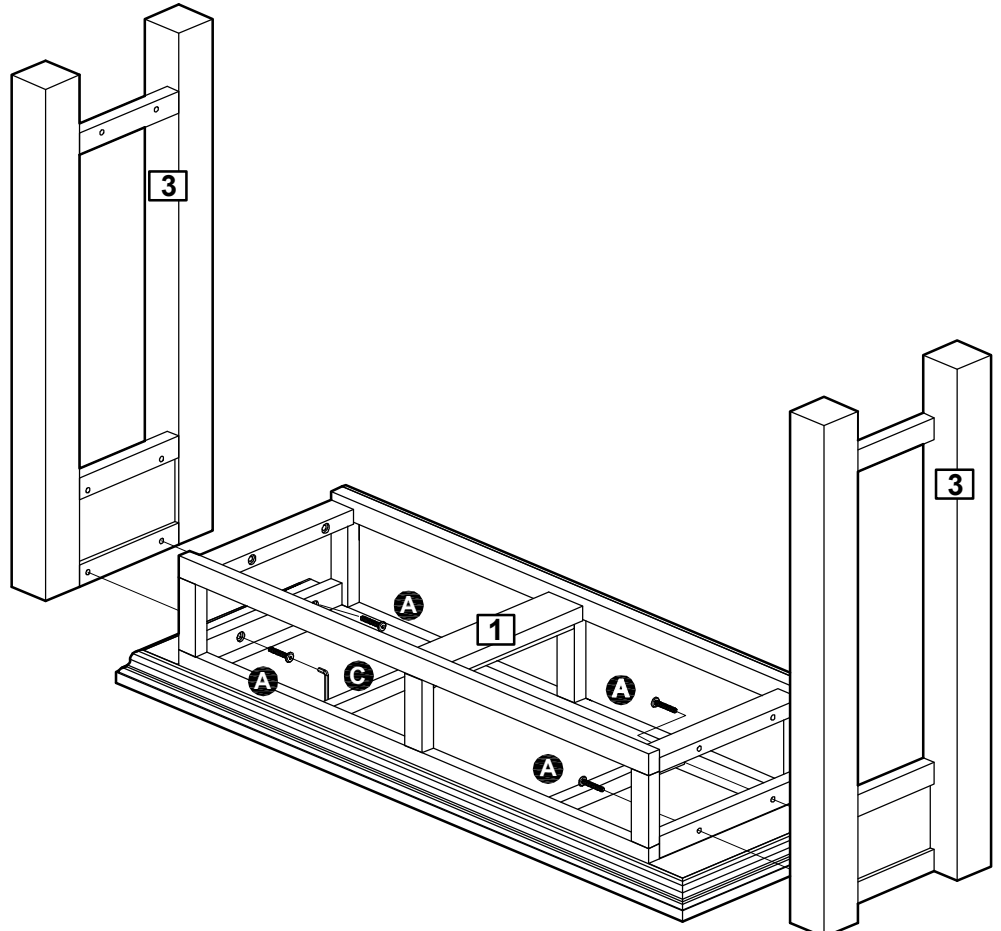

Assembly Instructions

Step 3

Securing the leg frames.

Attach the leg frames **3** to the top frame **1** using bolts **B** through the holes shown. Tighten with allen key **C**.

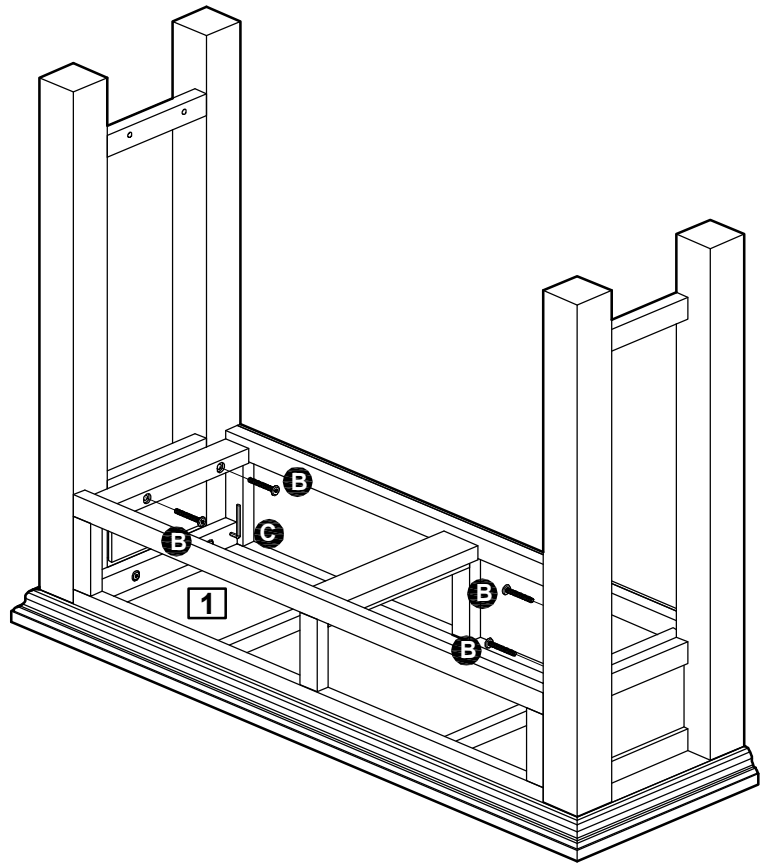

Step 4

Attaching shelf frame.

Position the shelf frame **2** between the side rails of leg frames **3** as shown. Fix through holes on shelf frame **2** using bolts **A**.

With the help of another person, turn the table over carefully .

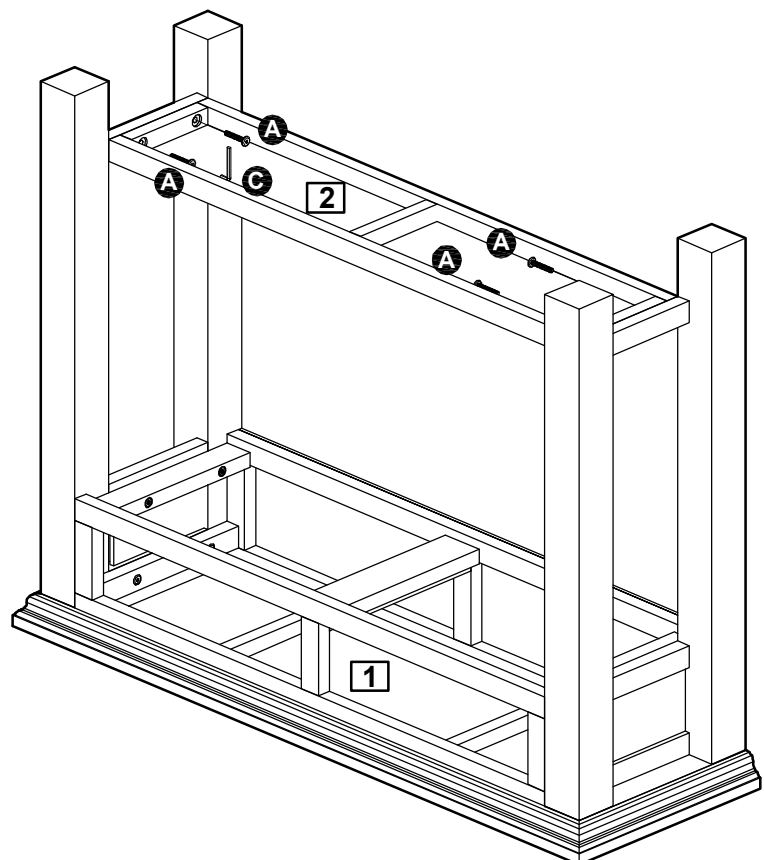

Assembly Instructions

Step 5

Inserting drawers.

Slide the drawer onto the runner. Turn the stopper to lock.

Repeat with the other drawer.

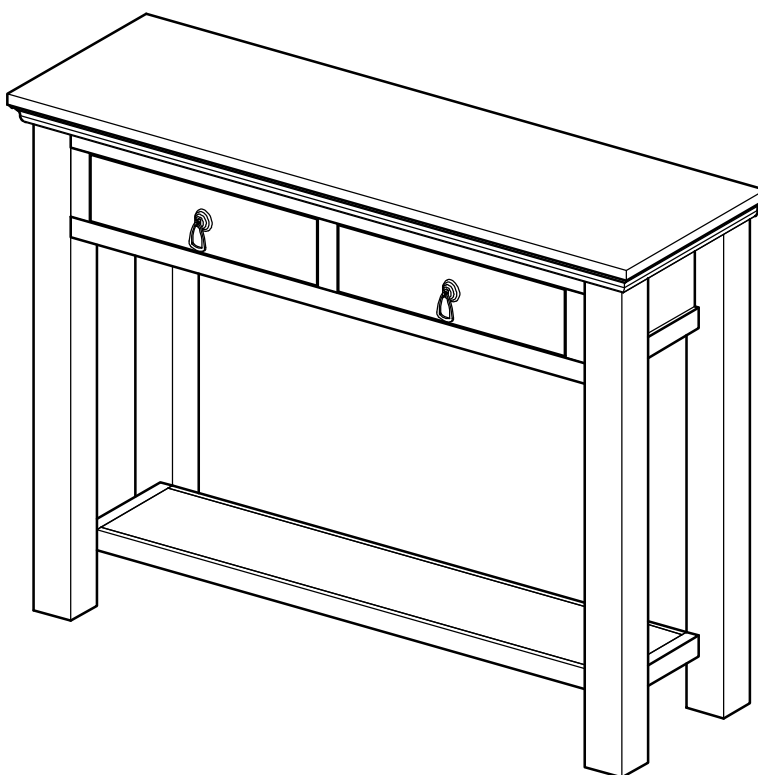
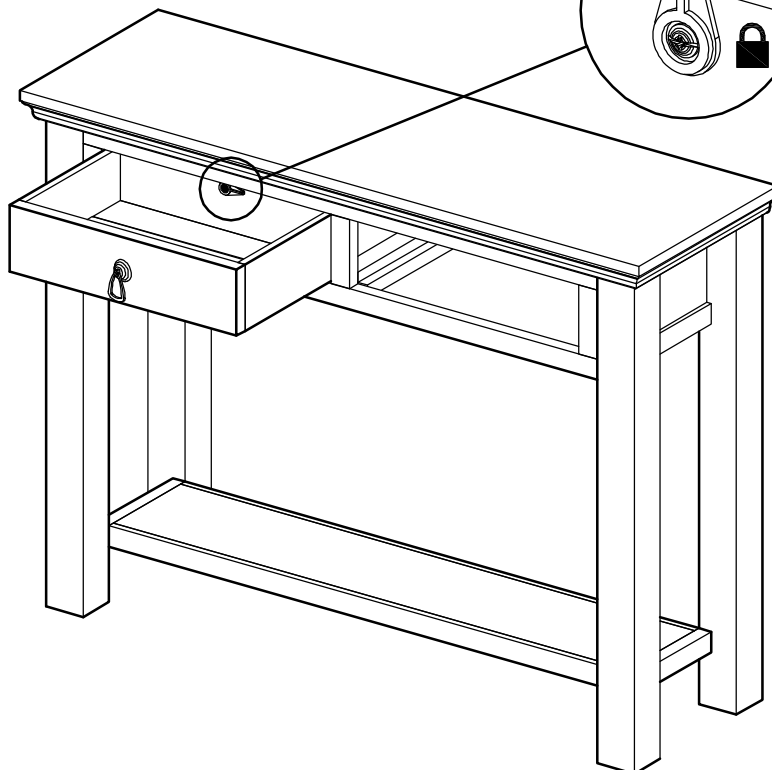
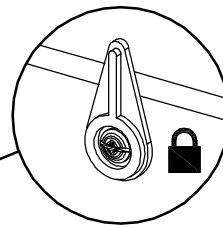

Assembly is complete.

If you need help or have damaged or missing parts, call the Customer Helpline: 0845 640 0800