



Register your new Bosch now:
www.bosch-home.com/welcome



**Fridge-freezer
KGE..**



BOSCH

en User manual

en Table of Contents

Safety and warning information	3	Freezing fresh food	13
Information concerning disposal	5	Super freezing	14
Scope of delivery	5	Thawing frozen food	15
Installation location	6	Interior fittings	15
Ambient temperature and ventilation ..	7	Sticker "OK"	16
Connecting the appliance	7	Switching off and disconnecting the appliance	17
Getting to know your appliance	8	Defrosting	17
Switching the appliance on	9	Cleaning the appliance	18
Setting the temperature	9	Odours	19
Holiday mode	10	Light (LED)	19
Alarm functions	10	Tips for saving energy	19
Usable capacity	11	Operating noises	20
Refrigerator compartment	11	Eliminating minor faults yourself	20
Super cooling	12	Appliance self-test	22
Freezer compartment	12	Customer service	22
Max. freezing capacity	12		
Freezing and storing food	12		

Safety and warning information

Before you switch ON the appliance

Please read the operating and installation instructions carefully! They contain important information on how to install, use and maintain the appliance.

The manufacturer is not liable if you fail to comply with the instructions and warnings. Retain all documents for subsequent use or for the next owner.

Technical safety

This appliance contains a small quantity of environmentally-friendly but flammable R600a refrigerant. Ensure that the tubing of the refrigerant circuit is not damaged during transportation and installation. Leaking refrigerant may cause eye injuries or ignite.

If damage has occurred

- Keep naked flames and/or ignition sources away from the appliance,
- thoroughly ventilate the room for several minutes,
- switch off the appliance and pull out the mains plug,
- inform customer service.

The more refrigerant an appliance contains, the larger the room must be in which the appliance is situated. Leaking refrigerant can form a flammable gas-air mixture in rooms which are too small.

The room must be at least 1 m³ per 8 g of refrigerant. The amount of refrigerant in your appliance is indicated on the rating plate inside the appliance.

If the power cord of this appliance is damaged, it must be replaced by the manufacturer, customer service or a similarly qualified person. Improper installations and repairs may put the user at considerable risk.

Repairs may be performed by the manufacturer, customer service or a similarly qualified person only.

Only original parts supplied by the manufacturer may be used. The manufacturer guarantees that only these parts satisfy the safety requirements.

An extension cable may be purchased from customer service only.

Important information when using the appliance

- Never use electrical appliances inside the appliance (e.g. heater, electric ice maker, etc.). Explosion hazard!
- Never defrost or clean the appliance with a steam cleaner! The steam may penetrate electrical parts and cause a short-circuit. Risk of electric shock!
- Do not use pointed or sharp-edged implements to remove frost or layers of ice. You could damage the refrigerant tubes. Leaking refrigerant may cause eye injuries or ignite.
- Do not store products which contain flammable propellants (e.g. spray cans) or explosive substances in the appliance. Explosion hazard!
- Do not stand on or lean heavily against base of appliance, drawers or doors, etc
- For defrosting and cleaning, pull the mains plug out or switch off the fuse. Do not pull out the mains plug by tugging on the power cord.
- Store high-percentage alcohol tightly closed and standing up.

■ **Avoiding placing children and vulnerable people at risk:**

At risk are children, people who have limited physical, mental or sensory abilities, as well as people who have inadequate knowledge concerning safe operation of the appliance.

Ensure that children and vulnerable people have understood the hazards.

A person responsible for safety must supervise or instruct children and vulnerable people who are using the appliance.

Only children from 8 years and above may use the appliance.

Supervise children who are cleaning and maintaining the appliance.

Never allow children to play with the appliance.

- Keep plastic parts and the door seal free of oil and grease. Otherwise, parts and door seal will become porous.
- Never cover or block the ventilation openings of the appliance!
- Do not store bottled or canned drinks (especially carbonated drinks) in the freezer compartment. Bottles and cans may burst!
- Never put frozen food straight from the freezer compartment into your mouth. Risk of low-temperature burns!
- Avoid prolonged touching of frozen food, ice or the evaporator pipes, etc. Risk of low-temperature burns!

Children in the household

- Keep children away from packaging and its parts.
Danger of suffocation from folding cartons and plastic film!
- Do not allow children to play with the appliance!
- If the appliance features a lock: keep the key out of the reach of children!

General regulations

The appliance is suitable

- for refrigerating and freezing food,
- for making ice.

This appliance is intended for use in the home and the home environment.

The appliance is suppressed according to EU Directive 2004/108/EC.

The refrigeration circuit has been checked for leaks.

This product complies with the relevant safety regulations for electrical appliances (EN 60335-2-24).

Information concerning disposal

Disposal of packaging

The packaging protects your appliance from damage during transit. All utilised materials are environmentally safe and recyclable. Please help us by disposing of the packaging in an environmentally friendly manner.

Please ask your dealer or inquire at your local authority about current means of disposal.

Disposal of your old appliance

Old appliances are not worthless rubbish! Valuable raw materials can be reclaimed by recycling old appliances.



This appliance is labelled in accordance with European Directive 2012/19/EU concerning used electrical and electronic appliances (waste electrical and electronic equipment - WEEE). The guideline determines the framework for the return and recycling of used appliances as applicable throughout the EU.

Warning

Redundant appliances

1. Pull out the mains plug.
2. Cut off the power cord and discard with the mains plug.

3. Do not take out the trays and receptacles: children are therefore prevented from climbing in!
4. Do not allow children to play with the appliance once it has spent its useful life. Danger of suffocation!

Refrigerators contain refrigerant and gases in the insulation. Refrigerant and gases must be disposed of professionally. Ensure that tubing of the refrigerant circuit is not damaged prior to proper disposal.

Scope of delivery

After unpacking all parts, check for any damage in transit.

If you have any complaints, please contact the dealer from whom you purchased the appliance or our customer service.

The delivery consists of the following parts:

- Free-standing appliance
- Interior fittings (depending on model)
- Bag containing installation materials
- Operating instructions
- Installation manual
- Customer service booklet
- Warranty enclosure
- Information on the energy consumption and noises

Installation location

A dry, well ventilated room is suitable as an installation location. The installation location should not be exposed to direct sunlight and not placed near a heat source, e.g. a cooker, radiator, etc. If installation next to a heat source is unavoidable, use a suitable insulating plate or observe the following minimum distances from the heat source:

- 3 cm to electric or gas cookers.
- 30 cm to an oil or coal-fired cooker.

The floor of the installation location must not give way; if required, reinforce floor. If the floor is uneven, compensate with supports.

Distance from wall

Fig. **3**

A gap is not required between the appliance and side wall. The containers and shelves are still fully extendable.

Reversing the door

(if required)

If required, we recommend that you have the door hinges changed over by our customer service. You can find out the costs for changing over the door hinges from your appropriate customer service.



Warning

While changing over the door hinges, ensure that the appliance is not connected to the power supply. Pull out the mains plug beforehand. To prevent damaging the back of the appliance, place adequate padding underneath. Carefully place the appliance on its back.

Note

If the appliance is placed on its back, ensure that the wall spacer is not fitted.

Ambient temperature and ventilation

Ambient temperature

The appliance is designed for a specific climate class. Depending on the climate class, the appliance can be operated at the following temperatures.

The climate class can be found on the rating plate. Fig. 20

Climate class	Permitted ambient temperature
SN	+10 °C to 32 °C
N	+16 °C to 32 °C
ST	+16 °C to 38 °C
T	+16 °C to 43 °C

Note

The appliance is fully functional within the room temperature limits of the indicated climatic class. If an appliance of climatic class SN is operated at colder room temperatures, the appliance will not be damaged up to a temperature of +5 °C.

Ventilation

Fig. 4

The air on the rear panel of the appliance heats up. Conduction of the heated air must not be obstructed. Otherwise, the refrigerating unit must work harder. This increases power consumption. Therefore: Never cover or block the ventilation openings!

Connecting the appliance

After installing the appliance, wait at least 1 hour until the appliance is switched on. During transportation the oil in the compressor may have flowed into the refrigeration system.

Before switching on the appliance for the first time, clean the interior of the appliance (see chapter “Cleaning the appliance”).

Electrical connection

The socket must be near the appliance and also freely accessible following installation of the appliance.

The appliance complies with the protection class I. Connect the appliance to 220–240 V/50 Hz alternating current via a correctly installed socket with protective conductor. The socket must be fused with a 10 to 16 A fuse.

For appliances operated in non-European countries, check whether the stated voltage and current type match the values of your mains supply. This information can be found on the rating plate. Fig. 20



Warning

Never connect the appliance to electronic energy saver plugs.

Our appliances can be used with mains and sine-controlled inverters. Mains-controlled inverters are used for photovoltaic systems which are connected directly to the national grid. Sine-controlled inverters must be used for isolated applications (e.g. on ships or in mountain lodges) which are not connected directly to the national grid.

Getting to know your appliance



Please fold out the illustrated last page. These operating instructions refer to several models.

The features of the models may vary.

The diagrams may differ.

Fig. **1**

* Not all models.

- 1-9 Controls
- 10 Light (LED)
- 11 Glass shelf in the refrigerator compartment
- 12 Chiller container
- 13 Vegetable container
- 14* Butter and cheese compartment
- 15* Door shelf "EasyLift"
- 16 Shelf for large bottles
- 17 Frozen food container (small)
- 18 Glass shelf in the freezer compartment
- 19 Frozen food container (large)
- 20 Condensation outlet
- 21 Height-adjustable feet

- A Refrigerator compartment
- B Freezer compartment

Controls

Fig. **2**

- 1 **On/Off button**
Serves to switch the whole appliance on and off.
- 2 **"Super" button (freezer compartment)**
Switches super freezing on and off.
- 3 **Temperature selection buttons freezer compartment**
These buttons set the temperature in the freezer compartment.
- 4 **Temperature display freezer compartment**
The numbers correspond to the set freezer compartment temperatures in °C.
- 5 **Alarm button**
Used to switch off the warning signal, see chapter "Alarm function".
- 6 **Holiday button**
Is used to switch vacation mode on and off (see chapter entitled Vacation mode).
- 7 **Temperature selection buttons refrigerator compartment**
These buttons set the temperature in the refrigerator compartment.
- 8 **Temperature display refrigerator compartment**
The numbers correspond to the set refrigerator compartment temperatures in °C.
- 9 **"Super" button refrigerator compartment**
Switches super cooling on and off.

Switching the appliance on

Fig. 2

1. Switch on the appliance with the On/Off button 1.

A warning signal sounds, the temperature display 4 flashes and the alarm button 5 is lit.

2. The warning signal is switched off by pressing the alarm button 5.

The appliance begins to cool. Light is switched on when the door is open.

The factory has recommended the following temperatures:

- Refrigerator compartment: +4 °C
- Freezer compartment: -18 °C

Operating tips

- When the appliance has been switched on, it may take several hours until the set temperatures have been reached.

Do not put any food in the appliance beforehand.

- The sides of the housing are sometimes heated slightly. This prevents condensation in the area of the door seal.
- If the freezer compartment door cannot be immediately re-opened after it has been closed, wait until the resulting low pressure has equalised.

Setting the temperature

Fig. 2

Refrigerator compartment

The temperature can be set from +2 °C to +8 °C.

Keep pressing temperature setting button on refrigerator compartment 7, until the required refrigerator compartment temperature is set.

The value last selected is saved. The set temperature is indicated on the temperature display for the refrigerator compartment 8.

Freezer compartment

The temperature can be set from -16 °C to -24 °C.

Keep pressing temperature setting button freezer compartment 3 until the required freezer compartment temperature is set.

The value last selected is saved. The set temperature is indicated on temperature display for the freezer compartment 4.

Holiday mode

If leaving the appliance for a long period of time, you can switch the appliance over to the energy-saving holiday mode.

The temperature of the refrigerator compartment is automatically switched to +14 °C.

Do not store any food in the refrigerator compartment during this time.

Switching on and off

Fig. 2

Press the holiday button 6.

If vacation mode is switched on, the button is lit and the refrigerator compartment temperature 8, no longer indicates a temperature.

Alarm functions

Door alarm

The door alarm switches on if the refrigerator compartment door is left open for longer than one minute. Close the door to switch off the warning signal.

Temperature alarm

The temperature alarm switches on if the freezer compartment is too warm and the frozen food is at risk of thawing.

When the alarm button 5 is pressed, the freezer compartment temperature display 4 indicates for five seconds the warmest temperature reached in the freezer compartment.

Then this value is deleted. The temperature display for the freezer compartment 4 indicates the set freezer compartment temperature without flashing.

Henceforth the “warmest temperature” will be redefined and saved.

The alarm may switch on without any risk to the frozen food:

- when the appliance is switched on,
- when large quantities of fresh food are placed in the appliance,
- if the freezer compartment door is open too long.

Note

Do not refreeze thawing or thawed food. Only ready meals (boiled or fried) may be refrozen.

No longer store the frozen produce for the max. storage period.

Switching off the alarm

Fig. 2

Press the alarm button 5 to switch off the warning signal.

Usable capacity

Information on the usable capacity can be found inside your appliance on the rating plate. Fig. 20

Fully utilising the freezer volume

The maximum amount of food can be placed in the freezer by removing all fittings. The food can be stacked directly on the shelves and in the bottom of the freezer compartment.

Removing the fittings

Pull out the frozen food container all the way, lift at the front and remove. Fig. 16

Refrigerator compartment

The refrigerator compartment is the ideal storage location for ready meals, cakes and pastries, preserved food, condensed milk, hard cheese, fruit and vegetables sensitive to cold.

Note when loading products

Wrap or cover food before placing in the appliance. This will retain the aroma, colour and freshness of the food. In addition, flavours will not be transferred between foods and the plastic parts will not become discoloured.

Note

Avoid contact between food and rear panel. Otherwise the air circulation will be impaired.

Food or packaging could freeze to the rear panel.

Note the chill zones in the refrigerator compartment

The air circulation in the refrigerator compartment creates different chill zones:

■ Coldest zone

is on the rear panel inside the appliance and in the chiller container. Fig. 11/12

Note

Store perishable food e.g. fish, sausage, meat in the coldest zones.

■ Warmest zone

is at the very top of the door.

Note

Store e.g. hard cheese and butter in the warmest zone. Cheese can then continue to release its flavour and the butter will still be easy to spread.

Super cooling

Super cooling sets the refrigerator temperature to the coldest temperature setting for approx. 15 hours. Then the appliance automatically switches to the temperature set prior to super cooling mode.

Switch on super cooling mode, e.g.

- before placing large quantities of food in the refrigerator compartment.
- for the fast cooling of drinks.

Note

When super cooling is switched on, increased operating noises may occur.

Switching on and off

Fig. 2

Press super button 9 refrigerator compartment.

The button is lit when super cooling is switched on.

Freezer compartment

Use the freezer compartment

- To store deep-frozen food.
- To make ice cubes.
- To freeze food.

Note

Ensure that the freezer compartment door has been closed properly. If the door is open, the frozen food will thaw. The freezer compartment will become covered in thick ice. Also: waste of energy due to high power consumption!

Max. freezing capacity

Information about the max. freezing capacity within 24 hours can be found on the rating plate. Fig. 20

Prerequisites for max. freezing capacity

- Switch on super freezing before placing fresh products in the compartment (see chapter entitled “Super freezing”).
- Remove the fittings. The food can be stacked directly on the shelves and in the bottom of the freezer compartment.
- Freeze large quantities of food preferably in the very top compartment where food freezes particularly quickly and therefore also gently.
- Freeze fresh food as close as possible to the side panels.

Freezing and storing food

Purchasing frozen food

- Packaging must not be damaged.
- Use by the “use by” date.
- Temperature in the supermarket freezer must be $-18\text{ }^{\circ}\text{C}$ or lower.
- If possible, transport deep-frozen food in an insulated bag and place quickly in the freezer compartment.

Freezing food

- Freeze fresh and undamaged food only.
- Keep food which is to be frozen away from food which is already frozen.
- To prevent food from losing its flavour or drying out, place in airtight containers.

Storing frozen food

Insert frozen food container all the way to ensure unrestricted air circulation.

If you have to store lots of food, it is possible to transfer the food to the glass shelves and stack it on the base of the freezer base.

1. To do this, remove all the frozen food containers.
2. Pull out the frozen food containers all the way, lift at the front and remove. Fig. 16

Freezing fresh food

Freeze fresh and undamaged food only.

To retain the best possible nutritional value, flavour and colour, vegetables should be blanched before freezing. Aubergines, peppers, zucchini and asparagus do not require blanching.

Literature on freezing and blanching can be found in bookshops.

Note

Keep food which is to be frozen away from food which is already frozen.

- The following foods are suitable for freezing:
Cakes and pastries, fish and seafood, meat, game, poultry, vegetables, fruit, herbs, eggs without shells, dairy products such as cheese, butter and quark, ready meals and leftovers such as soups, stews, cooked meat and fish, potato dishes, soufflés and desserts.
- The following foods are not suitable for freezing:
Types of vegetables, which are usually consumed raw, such as lettuce or radishes, eggs in shells, grapes, whole apples, pears and peaches, hard-boiled eggs, yoghurt, soured milk, sour cream, crème fraîche and mayonnaise.

Packing frozen food

To prevent food from losing its flavour or drying out, place in airtight containers.

1. Place food in packaging.
2. Remove air.
3. Seal the wrapping.
4. Label packaging with contents and date of freezing.

Suitable packaging:

Plastic film, tubular film made of polyethylene, aluminium foil, freezer containers.

These products are available from specialist outlets.

Unsuitable packaging:

Wrapping paper, greaseproof paper, cellophane, bin liners and used shopping bags.

Items suitable for sealing packaged food:

Rubber bands, plastic clips, string, cold-resistant adhesive tape, etc.

Bags and tubular film made of polyethylene can be sealed with a film heat sealer.

Shelf life of frozen food

Storage duration depends on the type of food.

At a temperature of -18 °C:

- Fish, sausage, ready meals and cakes and pastries:
up to 6 months
- Cheese, poultry and meat:
up to 8 months
- Vegetables and fruit:
up to 12 months

Super freezing

Food should be frozen solid as quickly as possible in order to retain vitamins, nutritional value, appearance and flavour. Several hours before placing fresh food in the freezer compartment, switch on super freezing to prevent an unwanted temperature rise.

As a rule, 4–6 hours is adequate.

This appliance runs constantly and the freezer compartment drops to a very low temperature.

If the max. freezing capacity is to be used, super freezing must be switched on for 24 hours before the fresh produce is placed in the freezer compartment.

Smaller quantities of food (up to 2 kg) can be frozen without “super freezing”.

Note

When super freezing is switched on, increased operating noises may occur.

Switching on and off

Fig. **2**

Press “super” button 2.

If the super freezing has been switched on the button is lit.

Super freezing automatically switches off after approx. 2½ days.

Thawing frozen food

Depending on the type and application, select one of the following options:

- at room temperature
- in the refrigerator
- in an electric oven, with/without fan assisted hot-air
- in the microwave

Caution

Do not refreeze thawing or thawed food. Only ready meals (boiled or fried) may be refrozen.

No longer store the frozen produce for the max. storage period.

Interior fittings

(not all models)

Butter and cheese compartment

To open the butter compartment, gently press in the middle of the butter compartment flap.

To clean the compartment, lift it at the bottom and take out.

Adjustable “EasyLift” door shelf

Fig. **5**

The height of the shelf can be adjusted without taking it out.

Simultaneously press side buttons on the shelf to move the shelf downwards. It can be moved upwards without pressing the buttons.

Bottle holder

Fig. **7**

The bottle holder prevents bottles from falling over when the door is opened and closed.

Glass shelves

Fig. **8**

If required, you can vary the shelves inside the appliance: To do this, pull out shelf, lift at the front and take out.

Variable shelf

Fig. **9**

The shelf can be folded down if required: Pull shelf forwards, lower and press backwards.

The shelf is suitable for storing food and bottles.

Pull-out container

Fig. **10**

You can take out the container for loading and unloading. To do this, lift the container and pull out. The holder of the container is variable.

Bottle shelf

Fig. **11**

Bottles can be stored securely on the bottle shelf. The holder can be adjusted.

Chiller container

Fig. **1**/12

Temperatures in the chiller container are lower than in the refrigerator compartment. Even temperatures below 0 °C may occur.

Ideal for storing fish, meat and sausage. Not suitable for lettuce, vegetables and produce sensitive to cold.

Vegetable container with humidity controller

Fig. 13

To create the optimum storage climate for fruit and vegetables, you can set the air humidity in the vegetable container depending on the quantity stored:

- smaller quantities of fruit and vegetables – high air humidity
- large quantities of fruit and vegetables – low air humidity

Notes

- Fruit sensitive to cold (e.g. pineapple, banana, papaya and citrus fruit) and vegetables sensitive to cold (e.g. aubergines, cucumbers, zucchini, peppers, tomatoes and potatoes) should be stored outside the refrigerator at temperatures of approx. +8 °C to +12 °C for optimum preservation of quality and flavour.
- Condensation may form in the vegetable container depending on the type and quantity of products stored. Remove condensation with a dry cloth and adjust air humidity in the vegetable container with the humidity controller.

Vegetable container insert

Fig. 14

The insert can be taken out.

Frozen food container (large)

Fig. 1/19

For the storage of large frozen items, e.g. turkey, duck and goose.

Note

Partition (if available) cannot be taken out.

Ice cube tray

Fig. 18

1. Fill the ice cube tray $\frac{3}{4}$ full of drinking water and place in the freezer compartment.
2. If the ice tray is stuck to the freezer compartment, loosen with a blunt implement only (spoon-handle).
3. To loosen the ice cubes, twist the ice tray slightly or hold briefly under flowing water.

Ice pack

Fig. 17

If a power failure or malfunction occurs, the ice packs can be used to slow down the thawing process. The longest storage time is obtained by placing the ice pack on the food in the top compartment.

Sticker “OK”

(not all models)

The “OK” temperature monitor can be used to determine temperatures below +4 °C. Gradually reduce the temperature if the sticker does not indicate “OK”.

Note

When the appliance is switched on, it may take 12 hours until the temperature is reached.



Correct setting

Switching off and disconnecting the appliance

Switching off the appliance

Fig. 2

Press the On/Off button 1. Temperature display goes out, refrigerating unit switches off.

Disconnecting the appliance

If you do not use the appliance for a prolonged period:

1. Switch off the appliance.
2. Pull out mains plug or switch off fuse.
3. Clean the appliance.
4. Leave the appliance door open.

Defrosting

Refrigerator compartment

Defrosting is actuated automatically.

The condensation flows into the evaporation area of the appliance via the condensation channels and the drainage hole.

Freezer compartment

The freezer compartment does not defrost automatically, otherwise the frozen food would start thawing. A layer of frost in the freezer compartment impairs refrigeration of the frozen food and increases power consumption. Remove the layer of hoarfrost regularly.

Caution

Do not scrape off hoarfrost or ice with a knife or pointed object. You could damage the refrigerant tubes. Leaking refrigerant may ignite or cause eye injuries.

Proceed as follows:

Note

Approx. 4 hours before defrosting the appliance, switch on super freezing so that the food drops to a very low temperature and can therefore be stored at room temperature for a longer period.

1. Switch off appliance to defrost it.
2. Pull out mains plug or switch off fuse.
3. Place the freezer drawers containing the food in a cool location. Place the ice pack (if enclosed) on the food.
4. Open condensation outlet. Fig. 15
5. The shelf for large bottles can be used to collect the condensation. To do this, take out the shelf for large bottles (see chapter entitled Cleaning the appliance) and place under the open condensation outlet.
6. To accelerate the defrosting process, place two pans of hot water on a trivet in the appliance.
7. When the freezer compartment has defrosted, pour the water out of the freezer drawer. Wipe any remaining water off the bottom of the freezer compartment with a sponge.
8. Close condensation outlet.
9. Re-insert shelf for large bottles into the door.
10. When defrosting is complete, connect and switch on the appliance again.

Cleaning the appliance

Caution

- Do not use abrasive, chloride or acidic cleaning agents or solvents.
- Do not use scouring or abrasive sponges.
The metallic surfaces could corrode.
- Never clean shelves and containers in the dishwasher.
The parts may become deformed!

Proceed as follows:

1. Before cleaning: Switch off the appliance.
2. Pull out mains plug or switch off fuse.
3. Take out the frozen food and store in a cool location. Place the ice pack (if enclosed) on the food.
4. Wait until the layer of frost has thawed.
5. Clean the appliance with a soft cloth, lukewarm water and a little pH neutral washing-up liquid. The rinsing water must not run into the light.
6. Wipe the door seal with clear water only and then wipe dry thoroughly.
7. After cleaning reconnect and switch the appliance back on.
8. Put the frozen food back into the appliance.

Interior fittings

All variable parts of the appliance can be taken out for cleaning.

Take out shelves in the door Fig. **6**

Lift shelves upwards and take out.

Take out glass shelves Fig. **8**

Lift the glass shelves, pull forwards, lower and swivel out to the side.

Taking out pull-out container Lift the container and pull out.

Condensation outlet fascia

To clean the condensation outlet channel, the glass shelf above the vegetable container, Fig. **11**/13, must be separated from the condensation outlet fascia:

1. Take out the glass shelf.
2. Lift condensation outlet fascia and take out. Fig. **12**

Note

Regularly clean the condensation channel and drainage hole with a cotton bud or similar implement to ensure that the condensation can drain.

Vegetable container Fig. **15**

The fascia of the vegetable container can be removed for cleaning.

Press side buttons in succession and remove fascia from the vegetable container.

Removing the container Fig. **5**

Pull out the container all the way, lift at the front and remove.

Odours

If you experience unpleasant odours:

1. Switch off the appliance with the On/Off button. Fig. 2/1
2. Take all food out of the appliance.
3. Clean interior (see chapter “Cleaning the appliance”).
4. Clean all packages.
5. Seal strong smelling food in order to avoid odours from forming.
6. Switch the appliance on again.
7. Store food in the appliance.
8. Check whether the formation of odours is still occurring after 24 hours.

Light (LED)

Your appliance features a maintenance-free LED light.

These lights may be repaired by customer service or authorised technicians only.

Tips for saving energy

- Install the appliance in a dry, well ventilated room! The appliance should not be installed in direct sunlight or near a heat source (e.g. radiator, cooker).
If required, use an insulating plate.
- Allow warm food and drinks to cool down before placing in the appliance.
- Thaw frozen food in the refrigerator compartment and use the low temperature of the frozen food to cool refrigerated food.
- Regularly defrost the freezer compartment to remove the layer of frost.
A layer of hoarfrost will impair refrigeration of the frozen food and increase power consumption.
- Open the appliance as briefly as possible.
- To avoid increased power consumption, occasionally clean the back of the appliance.
- If available:
Fit wall spacers to obtain the indicated energy rating of the appliance (see Installation instructions). A reduced wall gap will not restrict the function of the appliance. The energy rating may then increase slightly. The gap of 75 mm must not be exceeded.
- The arrangement of the fittings does not affect the energy rating of the appliance.

Operating noises

Quite normal noises

Droning

Motors are running (e.g. refrigerating units, fan).

Bubbling, humming or gurgling noises

Refrigerant is flowing through the tubing.

Clicking

Motor, switches or solenoid valves are switching on/off.

Preventing noises

The appliance is not level

Please align the appliance with a spirit level. Use the height-adjustable feet or place packing underneath them.

The appliance is not free-standing

Please move the appliance away from adjacent units or appliances.

Containers or storage areas wobble or stick

Please check the removable parts and re-insert them correctly if required.

Bottles or receptacles are touching each other

Move the bottles or receptacles slightly away from each other.

Eliminating minor faults yourself

Before you call customer service:

Please check whether you can eliminate the fault yourself based on the following information.

Customer service will charge you for advice – even if the appliance is still under guarantee!

Fault	Possible cause	Remedial action
Temperature differs greatly from the set value.		In some cases it is adequate to switch off the appliance for 5 minutes. If the temperature is too high wait a few hours and check whether the temperature has approached the set value. If the temperature is too low check the temperature again the next day.
Displays do not illuminate.	Power failure; the fuse has been switched off; the mains plug has not been inserted properly.	Connect mains plug. Check whether the power is on, check the fuses.
Temperature display indicates "E..".	Electronics have detected a fault.	Call customer service.

Fault	Possible cause	Remedial action
Warning signal sounds, “alarm” button lights up. Fig. 2/5 The freezer compartment is too warm! Frozen food is at risk!		To switch off the warning signal, press the “alarm” button 5.
	Appliance is open.	Close the appliance.
	Ventilation openings have been covered.	Ensure that there is adequate ventilation.
	Too much food was placed in the freezer compartment at once.	Do not exceed max. freezing capacity.
		When the fault has been eliminated, the “alarm” button 5 goes out shortly afterwards.
Freezer compartment temperature display flashes. Fig. 2/4 Warning signal sounds. The alarm button is lit. Fig. 2/5 The freezer compartment is too warm! Frozen food is at risk!		To switch off the warning signal, press the “alarm” button, Fig. 2/5.
	Appliance is open.	Close the appliance.
	Ventilation openings have been covered.	Ensure that there is adequate ventilation.
	Too much food was placed in the freezer compartment at once.	Do not exceed max. freezing capacity.
		When the fault has been eliminated, the alarm display goes out shortly afterwards.
Freezer compartment temperature display flashes. Fig. 2/4	A fault caused the freezer compartment to become too warm in the past.	When the alarm button 5 is pressed, the temperature display stops flashing. Fig. 2/4 The temperature display indicates for 5 seconds the warmest temperature which was reached in the freezer compartment.
Appliance is not cooling, temperature display and light are lit.	Showroom mode is switched on.	Hold down alarm button, Fig 2/5, for 10 seconds until an acknowledgement signal sounds. After a short time check whether your appliance is cooling.

Appliance self-test

Your appliance features an automatic self-test program which shows you sources of faults which may be repaired by customer service only.

Starting the appliance self-test

1. Switch off the appliance and wait 5 minutes.
2. Switch the appliance on.
3. Press alarm button, Fig. **2**/5, to switch off the warning signal.
If there is no warning signal, this step is not applicable.
4. Within the first 10 seconds after switching on the appliance, hold down the super button, Fig. **2**/2, for 3 to 5 seconds until an acoustic signal sounds.

The self-test programme starts. While the self-test is running, a long acoustic signal sounds.

When the self-test ends and an acoustic signal sounds twice, your appliance is in working order.

If the super button flashes for 10 seconds and 5 acoustic signals sound, there is a fault. Inform customer service.

Ending the appliance self-test

When the programme has ended, the appliance switches over to normal operation.

Customer service

Your local customer service can be found in the telephone directory or in the customer-service index. Please provide customer service with the appliance product number (E-Nr.) and production number (FD).

These specifications can be found on the rating plate. Fig. **20**

To prevent unnecessary call-outs, please assist customer service by quoting the product and production numbers. This will save you additional costs.

Repair order and advice on faults

Contact information for all countries can be found on the enclosed customer service list.

GB	0844 892 8979	Calls from a BT landline will be charged at up to 3 pence per minute. A call set-up fee of up to 6 pence may apply.
IE	01450 2655	0.03 € per minute at peak. Off peak 0.0088 € per minute.
US	800 944 2904	toll-free

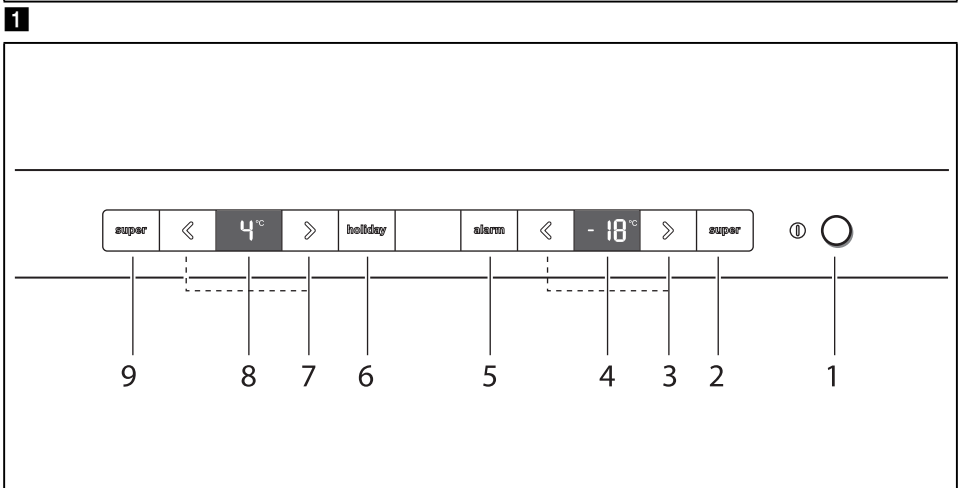
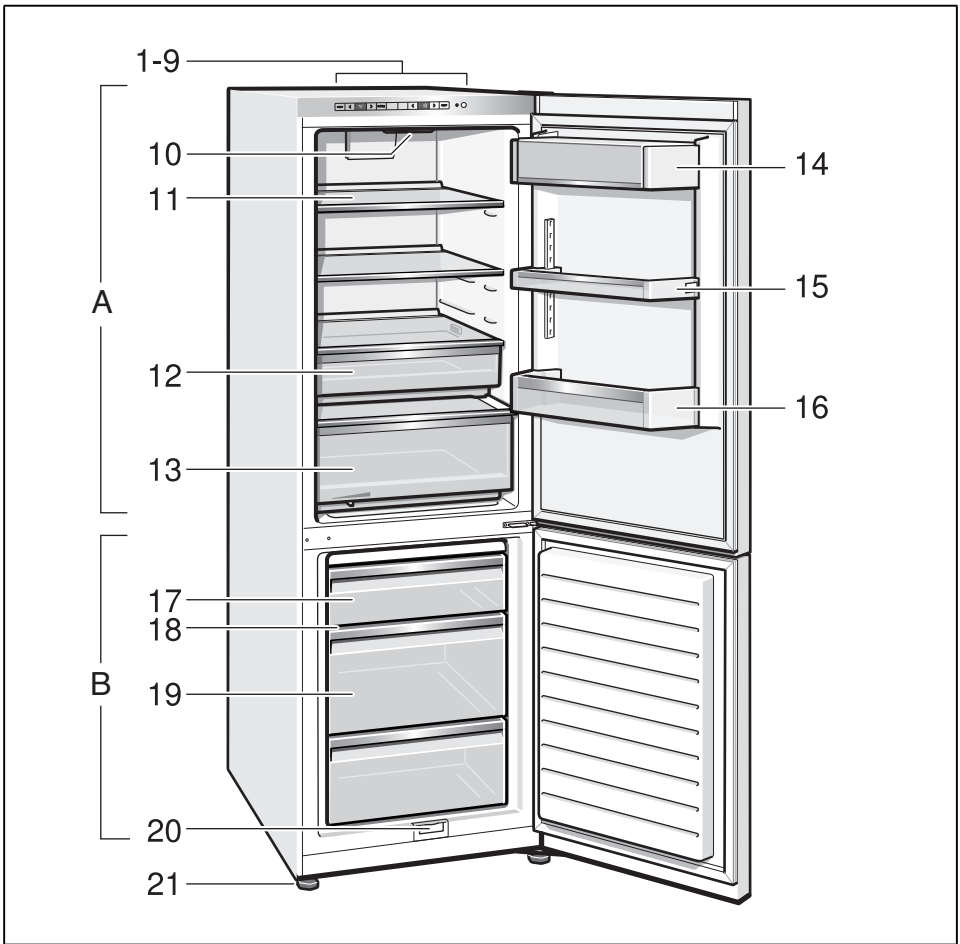

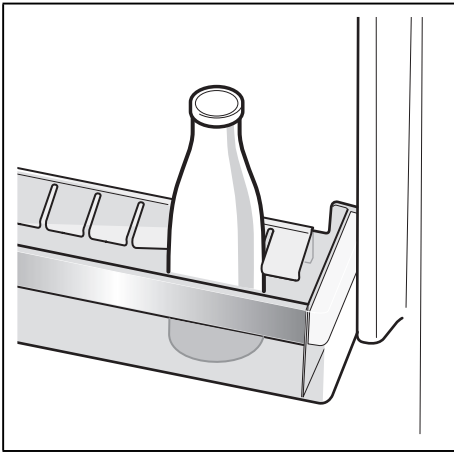
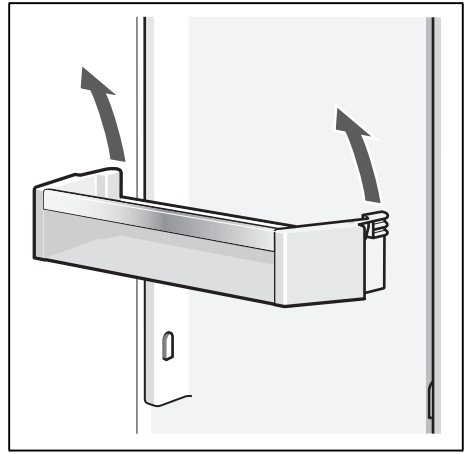
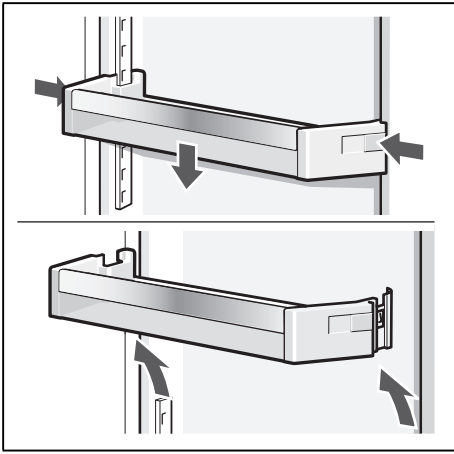
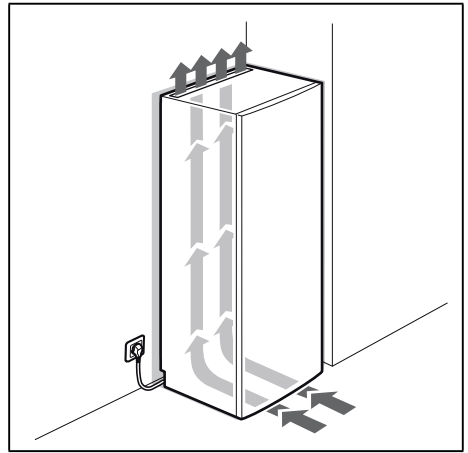
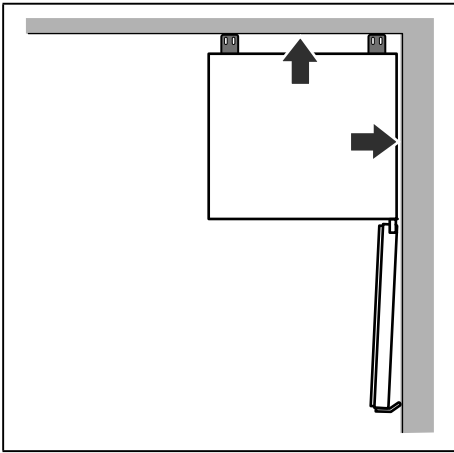

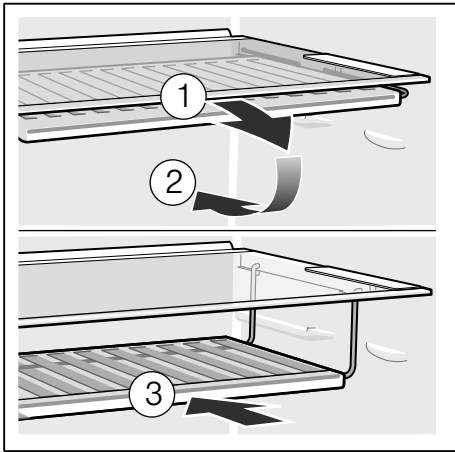

9

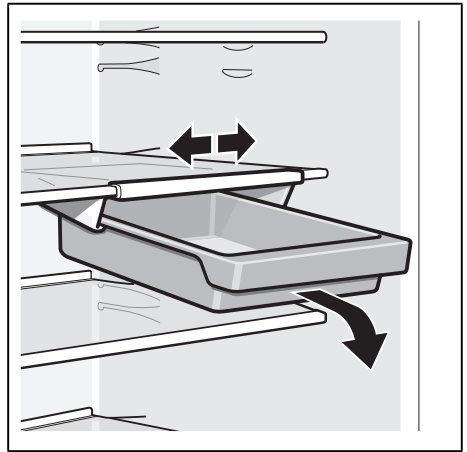

10

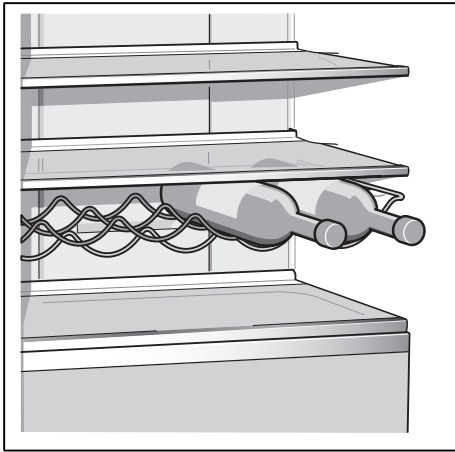

11



12

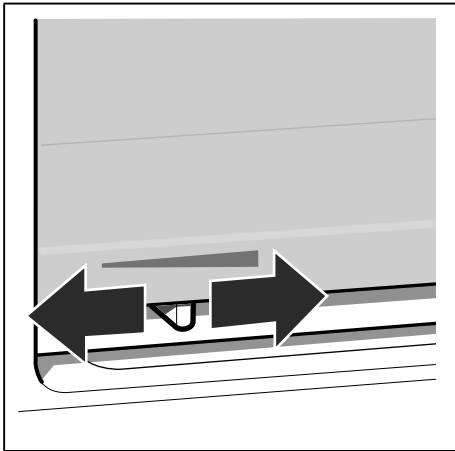

13

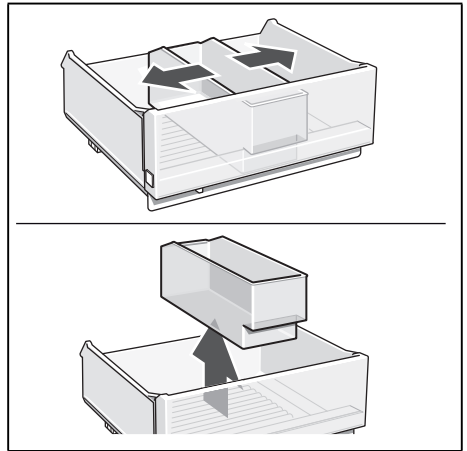

14

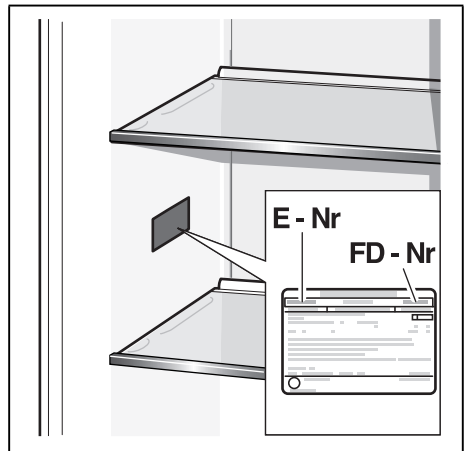
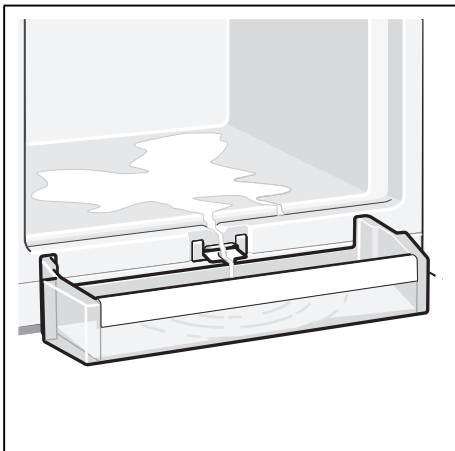
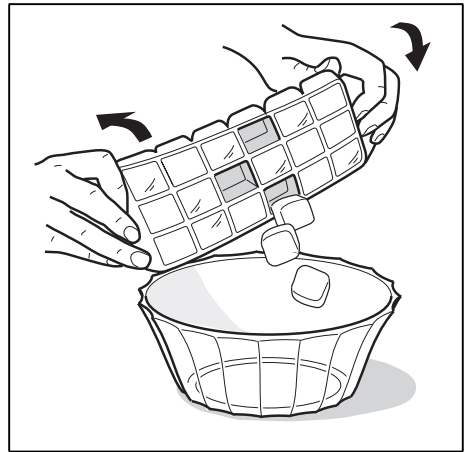
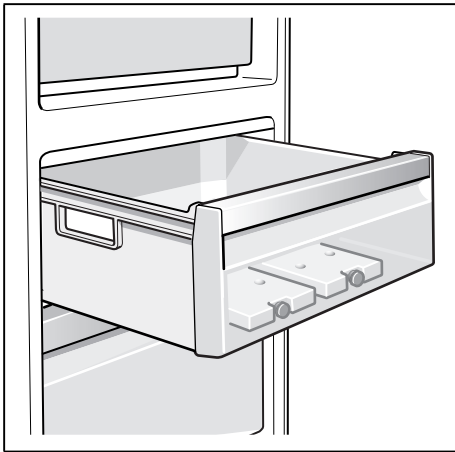
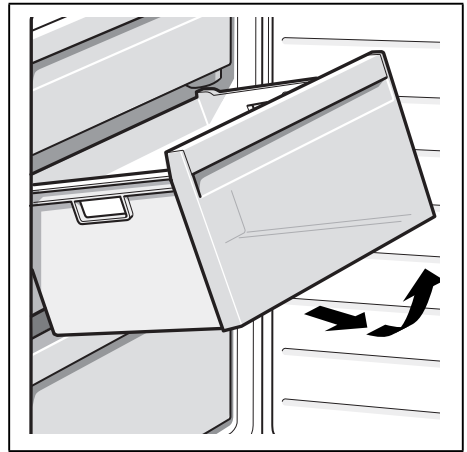
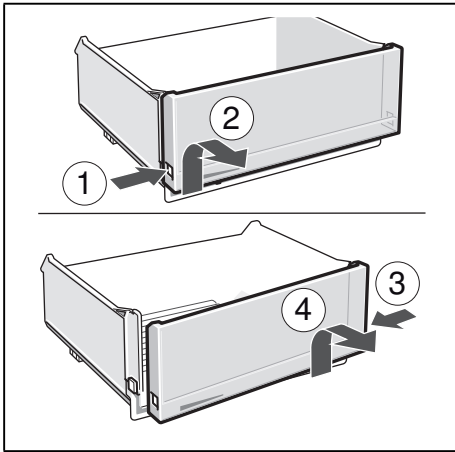



Robert Bosch Hausgeräte GmbH

Carl-Wery-Straße 34

81739 München, GERMANY

www.bosch-home.com

9000942059 (9504)
en