

# New Sywell - Dresser and Stool

Assembly Instructions - Please keep for future reference

239/6994

259/7975

247/9684

258/7040

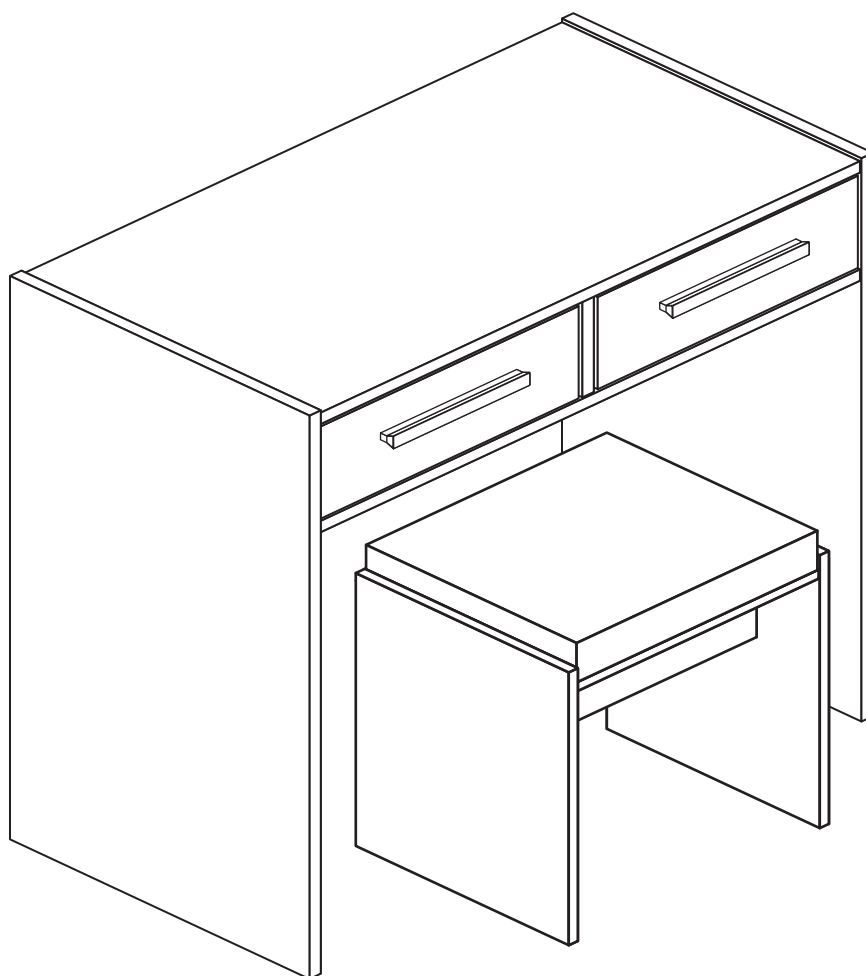

## Dresser Dimensions

Width - 77.5cm

Depth - 40cm

Height - 74.5cm

## Stool Dimensions

Width - 43cm

Depth - 35.5cm

Height - 48cm



**MADE IN  
BRITAIN**

**Important** - Please read these instructions fully before starting assembly

If you need help or have damaged or missing parts, call the **Customer Helpline: 08456 400800**



# Safety and Care Advice

**Important - Please read these instructions fully before starting assembly**

- **Warning:** This unit weighs approximately 24kgs. Please lift with care.

- Check you have all the components and tools listed on pages 2 and 3.

- Remove all fittings from the plastic bags and separate them into their groups.

- Keep children and animals away from the work area, small parts could choke if swallowed.

- Parts of the assembly will be easier with 2 people.

- Make sure you have enough space to layout the parts before starting.

- Do not stand or put weight on the product, this could cause damage.

- Assemble the item as close to its final position (in the same room) as possible.

- Assemble on a soft level surface to avoid damaging the unit or your floor (use opened out unit carton).



- We do not recommend the use of power drill/drivers **for inserting screws**, as this could damage the unit. Only use hand screwdrivers.

- **Safety note:** It is recommended that this unit is secured to a wall using the bracket supplied.

- Dispose of all packaging carefully and responsibly.

## Care and maintenance

- Only clean using a damp cloth and mild detergent, do not use bleach or abrasive cleaners.

- From time to time check that there are no loose screws on this unit.

- This product should not be discarded with household waste. Take to your local authority waste disposal centre.

**Note:** If required the next page can be cut out and used as reference throughout the assembly. Keep this page with these instructions for future reference.

# Components - Panels

If you have damaged or missing components, call the **Customer Helpline: 08456 400800** quoting the reference numbers below

Please check you have all the panels listed below

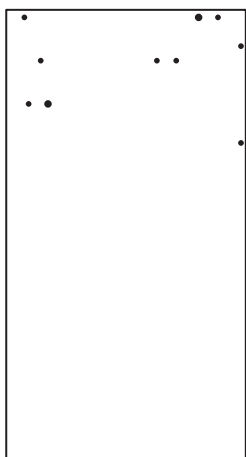

**1** Left Side (DF745)  
(745 x 396mm)

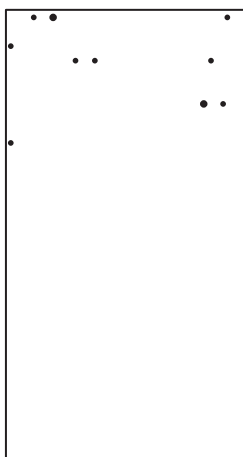

**2** Right Side (DF746)  
(745 x 396mm)

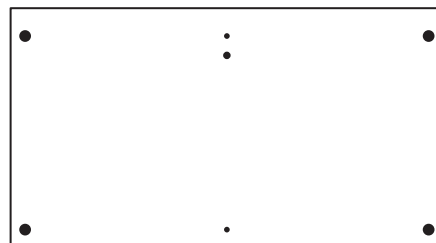

**3** Top (DF1348)  
(745 x 396mm)

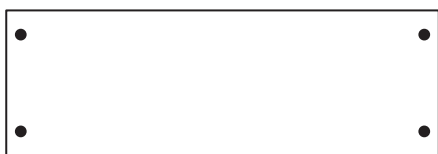

**4** Modesty (DF748)  
(715 x 243mm)

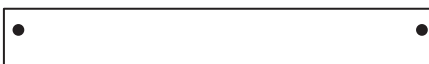

**5** Rail (DF753)  
(715 x 97mm)

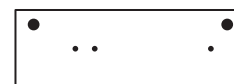

**6** Divider (DF887)  
(128 x 376mm)

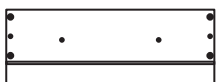

**7** Drawer Front (DF888)  
(344 x 122mm) x 2

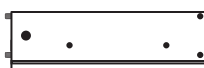

**8** Left Drawer Side (W320-95LH)  
(320 x 95mm) x 2

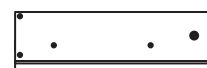

**9** Right Drawer Side (W320-95RH)  
(320 x 95mm) x 2



**10** Drawer Back (W317-95)  
(317 x 95mm) x 2

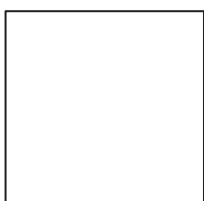

**11** Drawer Base (T328-317)  
(328 x 317mm) x 2

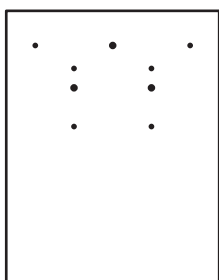

**12** Stool Side (D0996A)  
(451 x 352mm) x 2

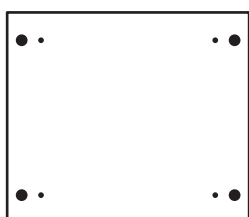

**13** Stool Base (D0997A)  
(400 x 348mm)



**14** Stool Rail (D0998A)  
(400 x 144mm) x 2



**15** Seat Pad (FMANPAD)  
(398 x 348mm)











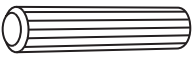
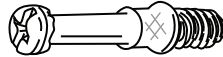

# Components - Fittings

If you have damaged or missing components, call the **Customer Helpline: 08456 400800** quoting the reference numbers below

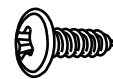
Please check you have all the fittings listed below

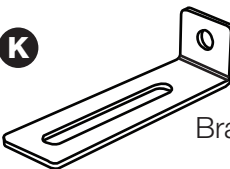
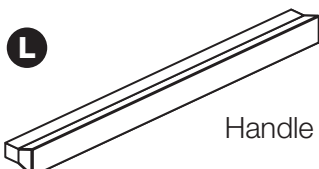
**Note:** The quantities below are the correct amount to complete the assembly. In some cases more fittings may be supplied than are required.

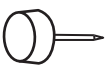
<p><b>A</b> </p> <p>Wooden dowel (F22) x 11</p>	<p><b>B</b> </p> <p>Metal dowel (F901) x 28</p>	<p><b>C</b> </p> <p>Knock-in Peg (F171) x 8</p>
<p><b>D</b> </p> <p>Large locking nut (F900) x 24</p>	<p><b>E</b> </p> <p>Small locking nut (F3) x 4</p>	<p><b>F</b> </p> <p>25mm Screw (F95) x 4</p>
<p><b>G</b> </p> <p>25mm Screw (F50) x 4</p>	<p><b>H</b> </p> <p>13mm Screw (F79) x 1</p>	<p><b>I</b> </p> <p>9mm Screw (F74) x 4</p>
<p><b>J</b> </p> <p>9mm Screw (F73) x 8</p>	<p><b>K</b> </p> <p>Bracket (F327) x 1</p>	<p><b>L</b> </p> <p>Handle (F315) x 2</p>
<p><b>M</b> </p> <p>Drawer runner (F1004) x 4</p>		
<p><b>N</b> </p> <p>Wedgefix (F639) x 4</p>	<p><b>O</b> </p> <p>Plastic Nail (F91) x 8</p>	

## Tools required



Rule



Cross-head screwdriver



Scissors



Hammer



Eye protection (when using a hammer or drill)



Electric drill (do not use for fitting screws)

Ruler - Use this ruler to help correctly identify the screws

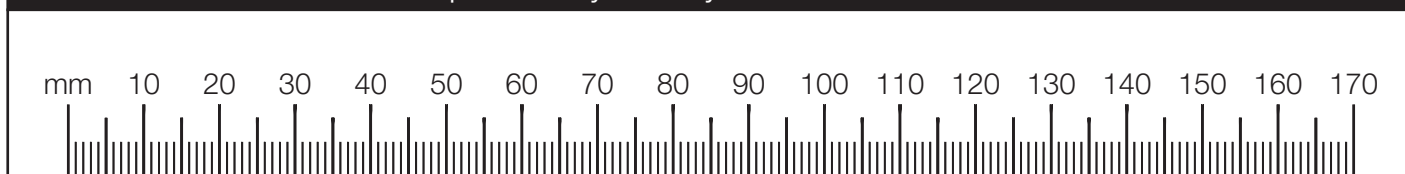



# Assembly Instructions

If you have damaged or missing components, call the  
**Customer Helpline: 08456 400800** quoting the reference  
numbers below

## Step 1

### Prepare the 2 drawer fronts

Screw 2 metal dowels **B** into each of the 2 drawer fronts **7**.

**Note:** Tighten the metal dowels up fully against the panels.

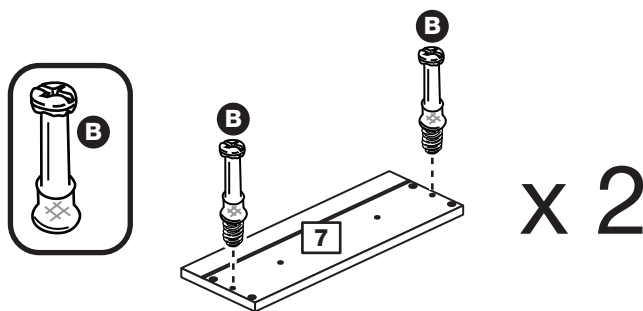

## Step 2

### Prepare the drawer sides

Insert a small locking nut **E** into the hole shown on the left drawer side **8** and the right drawer side **9**.

**Note:** The arrow on the locking nut **must** point towards the hole in the edge of the panel.

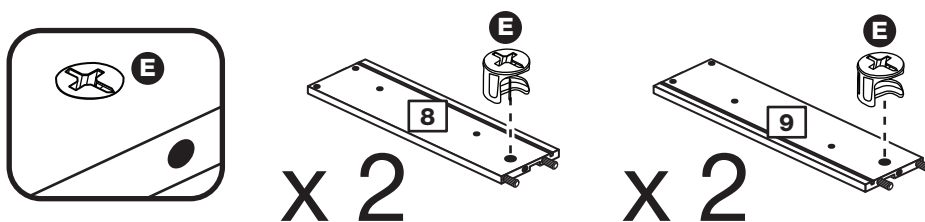

## Step 3

### Attach the drawer sides to the drawer fronts

Push the left drawer sides **8** and right drawer sides **9** onto the back of the drawer fronts **7**.

Turn the small locking nuts **E** on the left drawer side **8** and right drawer side **9**.

**Note:** Turn the locking nuts **E** clockwise to secure panels - more than 1/2 a turn.

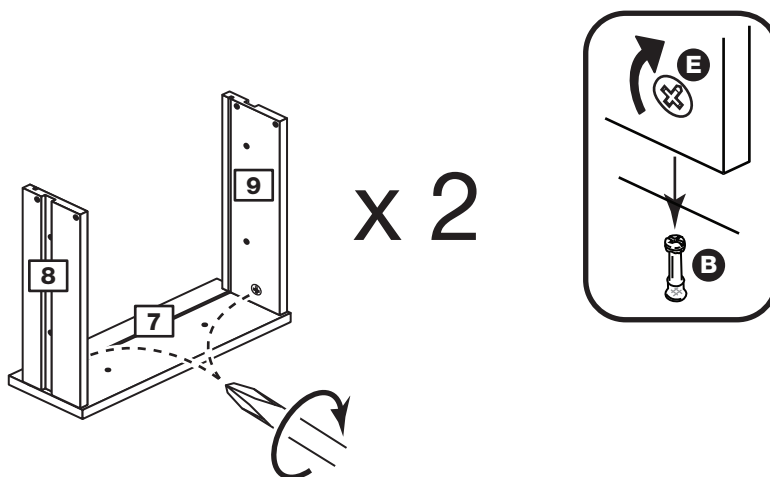

# Assembly Instructions

## Step 4

### Fit the drawer bases

Slide the drawer base **11** down the grooves in the drawer sides **8** and **9** and down into the groove in the drawer front **7**.

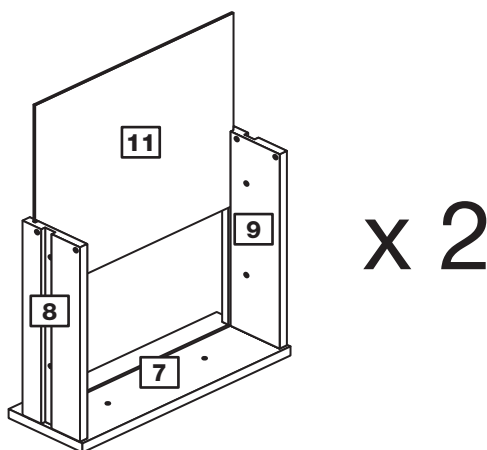

## Step 5

### Fit the drawer backs

Fit the drawer back **10** between the drawer sides **8** and **9**. Make sure that the drawer base **11** fits into the groove in the drawer back **10**.

Hold the drawer back **10** in position and tap the knock-in pegs **C** through the holes in the drawer sides **8** and **9**.

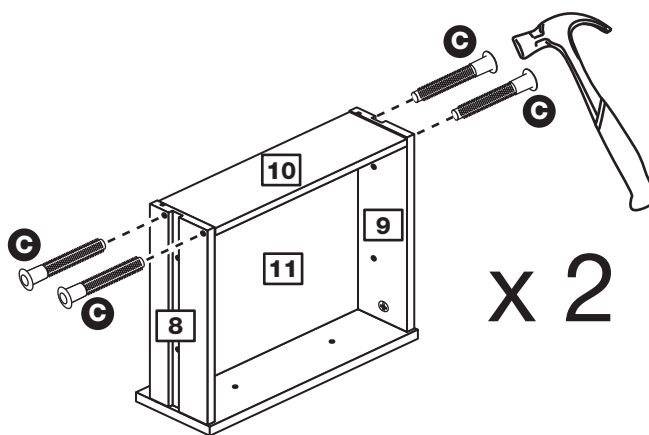

## Step 6

### Attach the handles

Attach a handle **L** to each drawer front **7** using 2 screws **F**.

**Note: Do not overtighten the screw.**

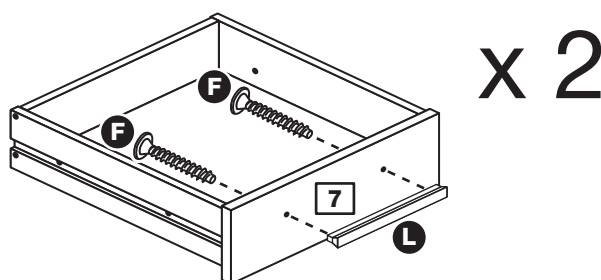

## Step 7

### Fit the wedgifixes

Turn the drawer assemblies over and slide 2 wedgifixes **N** into the front and back grooves, as shown, and tighten up the screws.

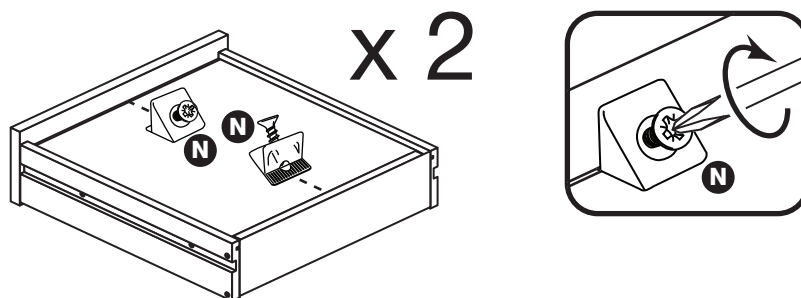

# Assembly Instructions

## Step 8

### Prepare the left side

**a:** Place a runner **M** on the left side **1**. Slide back the top of the runner and use the 2nd hole from the front to fit the 1st screw **J**.

**b:** Slide the runner back the other way and fit the 2nd screw **J** into the corresponding hole in the left side **1**.

**c:** Screw 5 metal dowels **B** into the left side **1**.

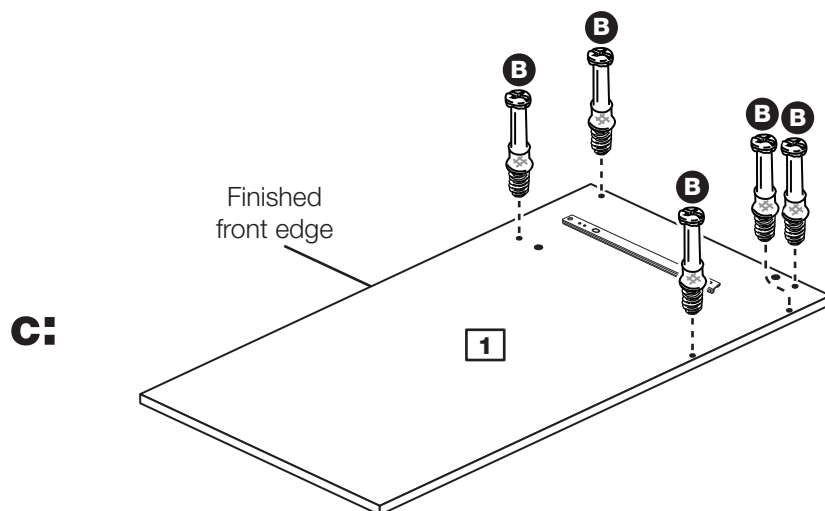
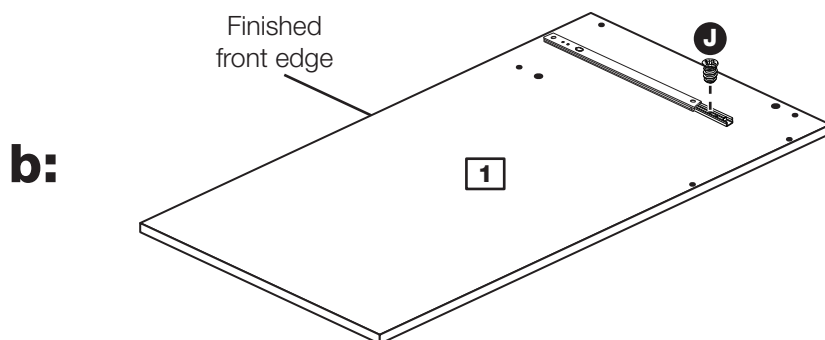
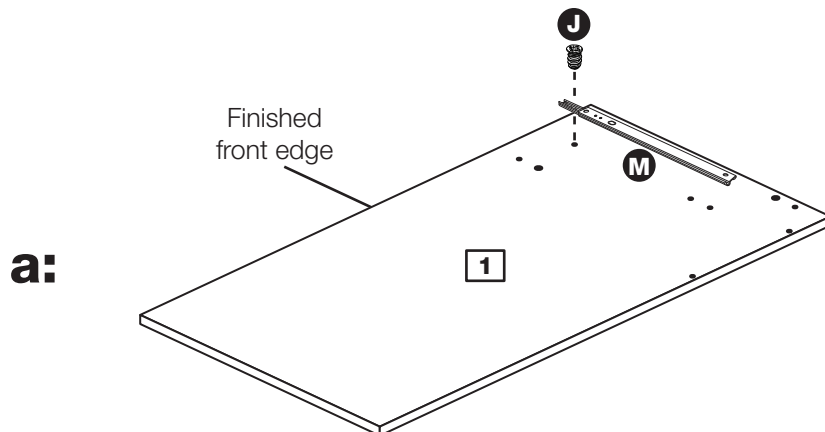
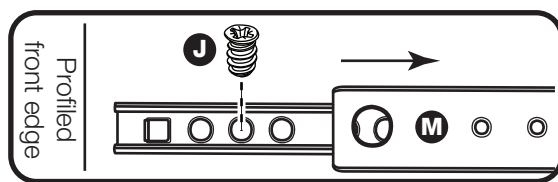

# Assembly Instructions

## Step 9

### Prepare the right side

**a:** Place a runner **M** on the right side **2**. Slide back the top of runner and use the 2nd hole from the front to fit the 1st screw **J**.

**b:** Slide the runner **M** back the other way and fit the 2nd screw **J** into the corresponding hole on the right side **2**.

**c:** Screw 5 metal dowels **B** into the right side **2**.

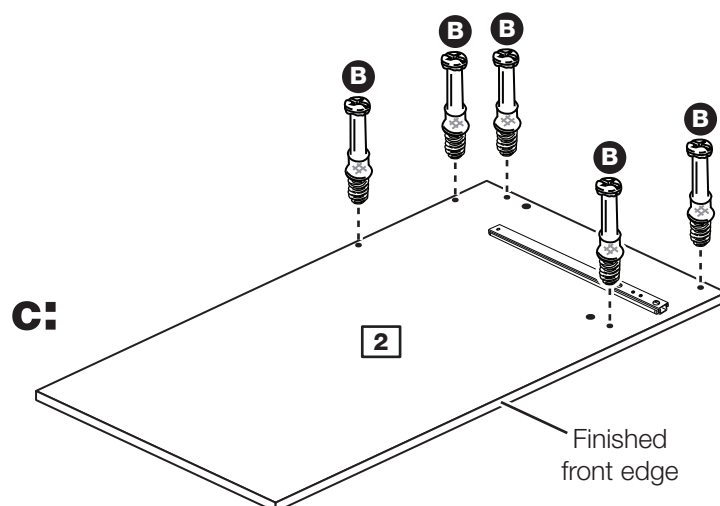
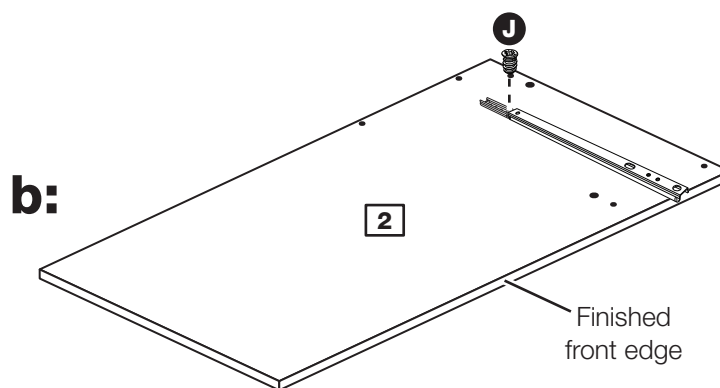
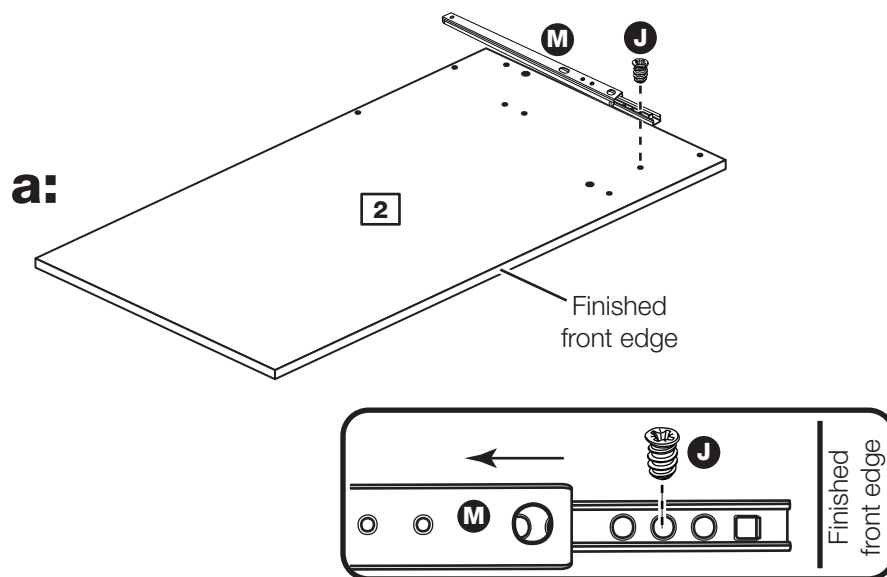

# Assembly Instructions

## Step 10

### Prepare the top

Tap 2 wooden dowels **A** into the top **3**.

**Note:** Wooden dowels **must not** stick out from the edge by more than 10mm or they may damage other panels.

Screw 2 metal dowels **B** into the top **3**.

Insert 4 large locking nuts **D** into the top **3**.

**Note:** The arrow on the locking nut **must** point towards the hole in the edge of the panel.

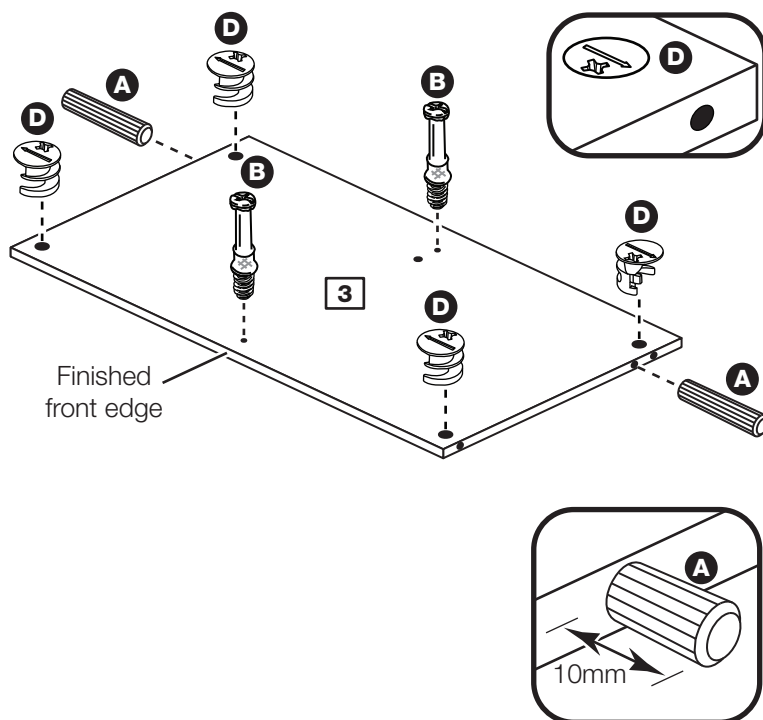

## Step 11

### Fit the top

Push the top **3** onto the right side **2**.

Use a screwdriver to tighten the 2 large locking nuts **D** fitted to the right side **2**.

**Note:** Turn the large locking nuts **D** as far as they will go - more than 1/2 a turn.

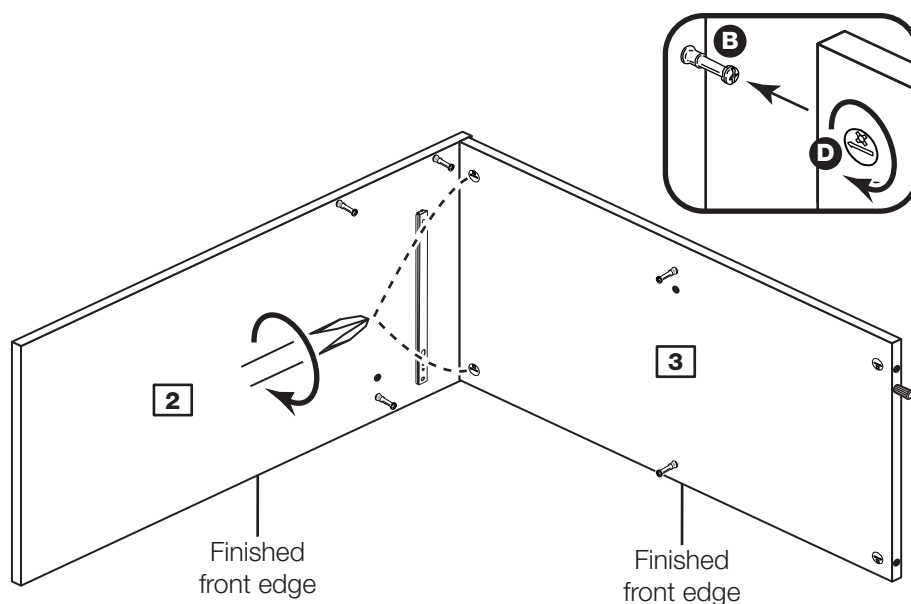

# Assembly Instructions

## Step 12

### Prepare the divider

**a:** Place a runner **M** on the divider **6** as shown. Slide back the top of runner and use the 2nd hole from the front to fit the 1st screw **J**.

**b:** Slide the runner **M** back the other way and fit the 2nd screw **J** into the corresponding hole in the divider **6**.

Tap a wooden dowel **A** into the divider **6**.

Insert 2 large locking nuts **D** into the divider **6**.

### Turn the divider over

**c:** Place a runner **M** on the divider **6** as shown. Slide back the top of runner and use the 2nd hole from the front to fit the 1st screw **J**.

**d:** Slide the runner **M** back the other way and fit the 2nd screw **J** into the corresponding hole in the divider **6**.

**Note:** Due to the manufacturing process, the 2 holes for the large locking nut can be on either surface of the divider.

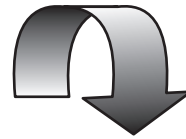
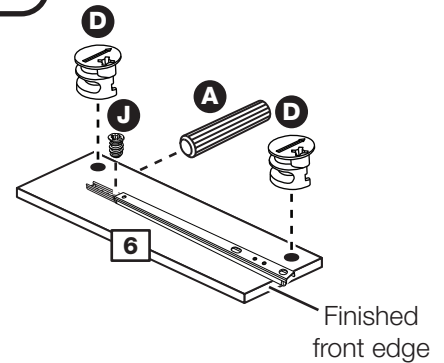
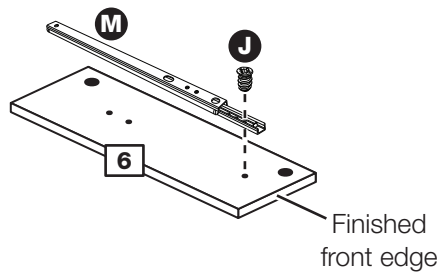
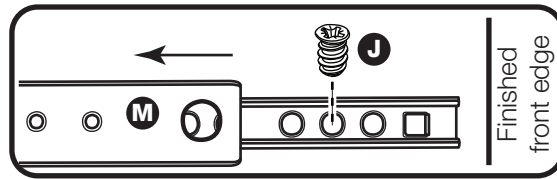

### Turn the divider over

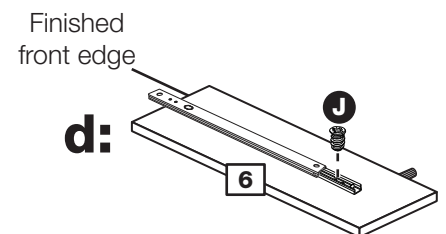
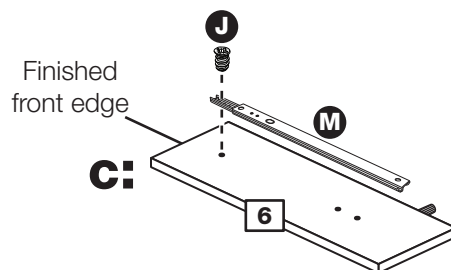
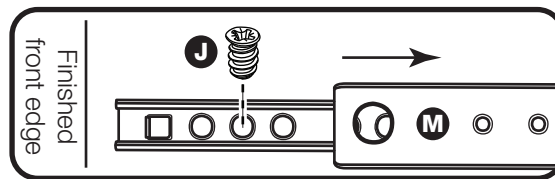

# Assembly Instructions

## Step 13

### Fit the divider

Push the divider **6** onto the top **3**.

Use a screwdriver to tighten the 2 large locking nuts **D** fitted to the divider **6**.

**Note:** The large locking nuts can be on either surface of the divider.

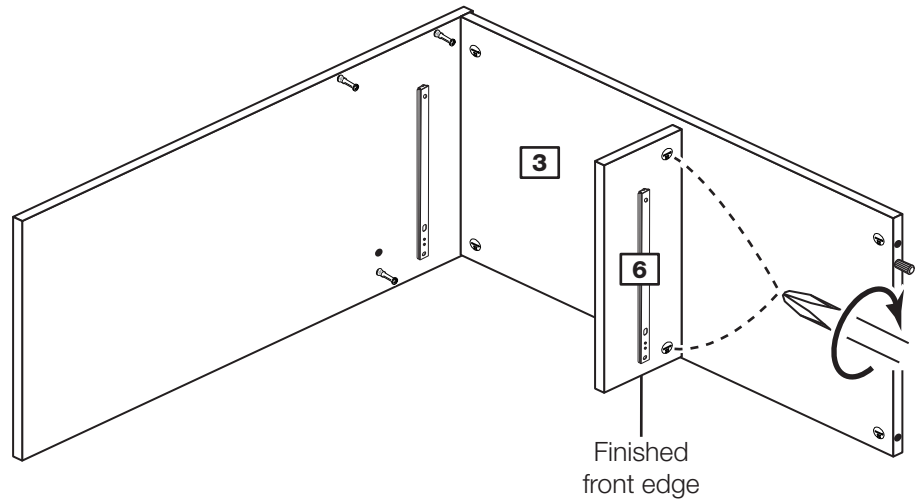

## Step 14

### Prepare the rail

Tap 2 wooden dowels **A** into the rail **5**.

Insert 2 large locking nuts **D** into the rail **5**.

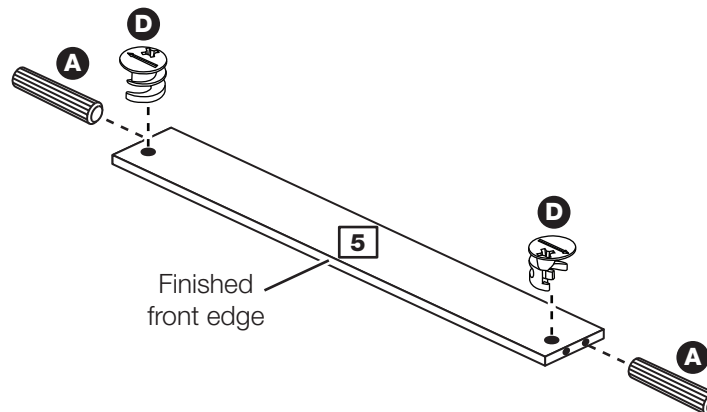

## Step 15

### Fit the rail

Push the rail **5** onto the right side **2**.

Use a screwdriver to tighten the large locking nut **D** fitted to the rail **5**.

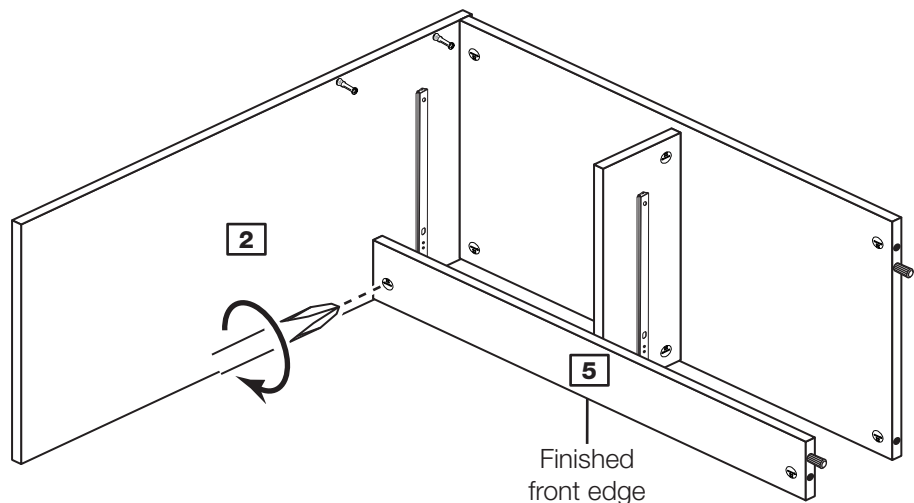

# Assembly Instructions

## Step 16

### Prepare the modesty

Insert 4 large locking nuts **D** into the modesty **4**.

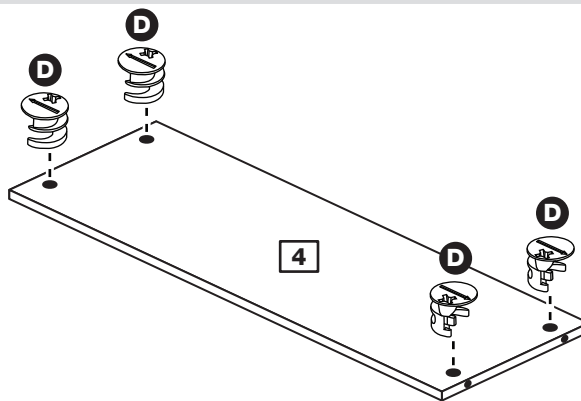

## Step 17

### Fit the rail

Push the modesty **4** onto the right side **2**.

Use a screwdriver to tighten the large locking nut **D** fitted to the modesty **4**.

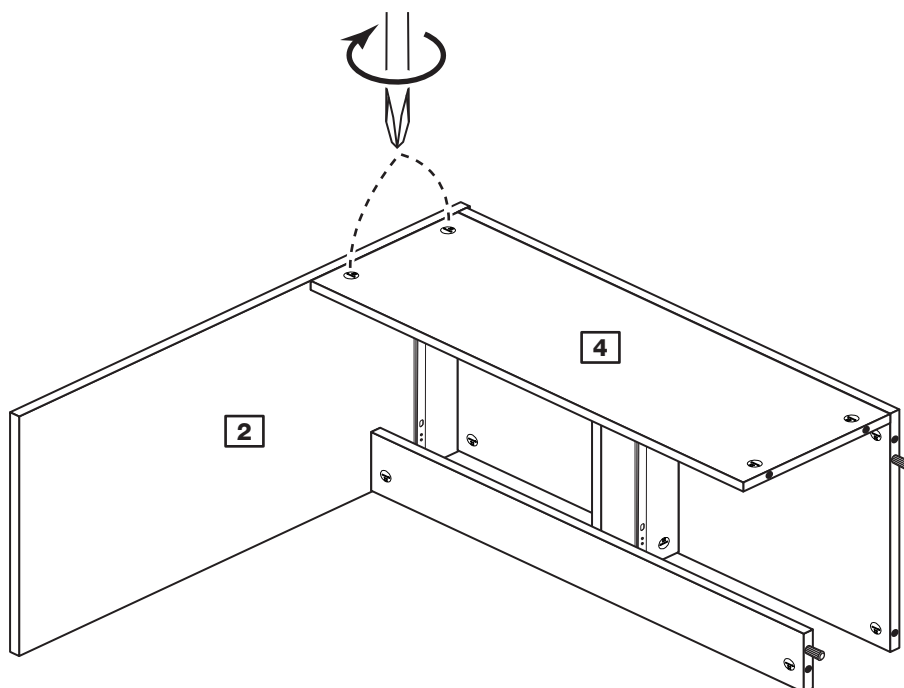

## Step 18

### Fit the left side

Push the left side **1** onto the assembly.

Use a screwdriver to tighten the 5 large locking nuts **D** fitted to the top **3**, modesty **4** and rail **5**.

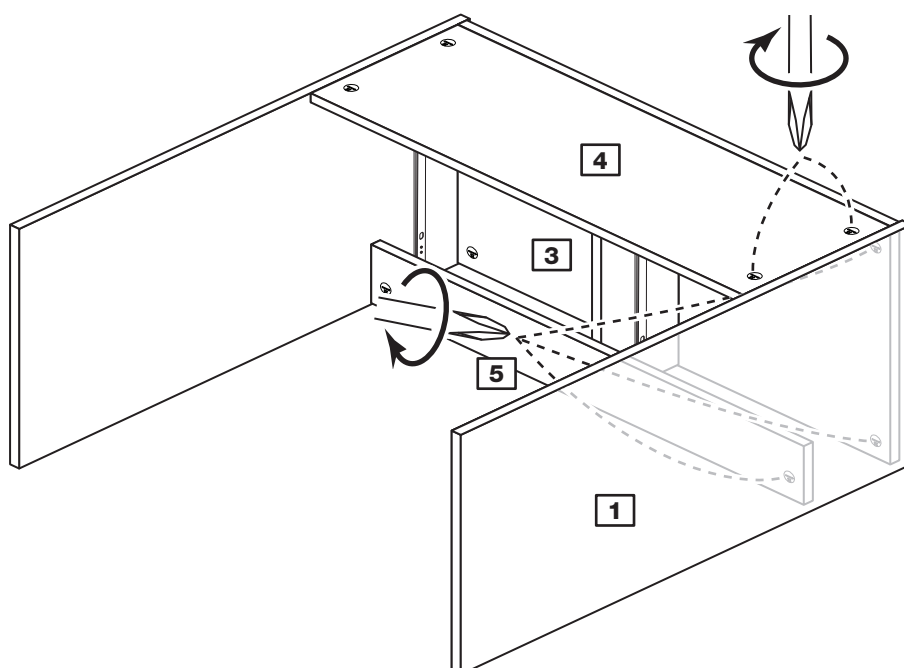



# Assembly Instructions

## Step 19

### Fit the plastic nails

Tap 2 plastic nails **O** into the bottom edge of each of the sides **1** and **2** as shown.

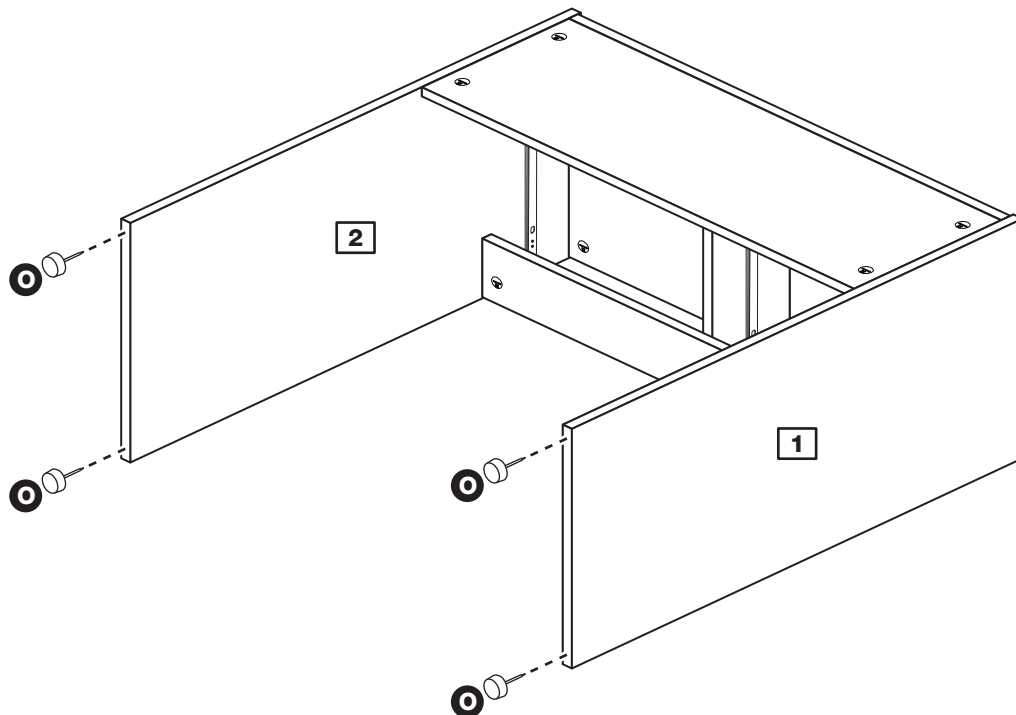

## Step 20

### Fit the drawers

Slide both of the runners **M** forward and locate the drawer sides **10** and **11** between them, lining up the holes in the drawer sides with the 2nd 'threaded' holes in the runners.

Working from the inside of the drawer, insert 2 screws **I** through the drawer sides and out into the 2nd threaded hole in the runner.

**Note:** Do not overtighten the screws.

If they catch on the runner you may need to loosen them slightly.

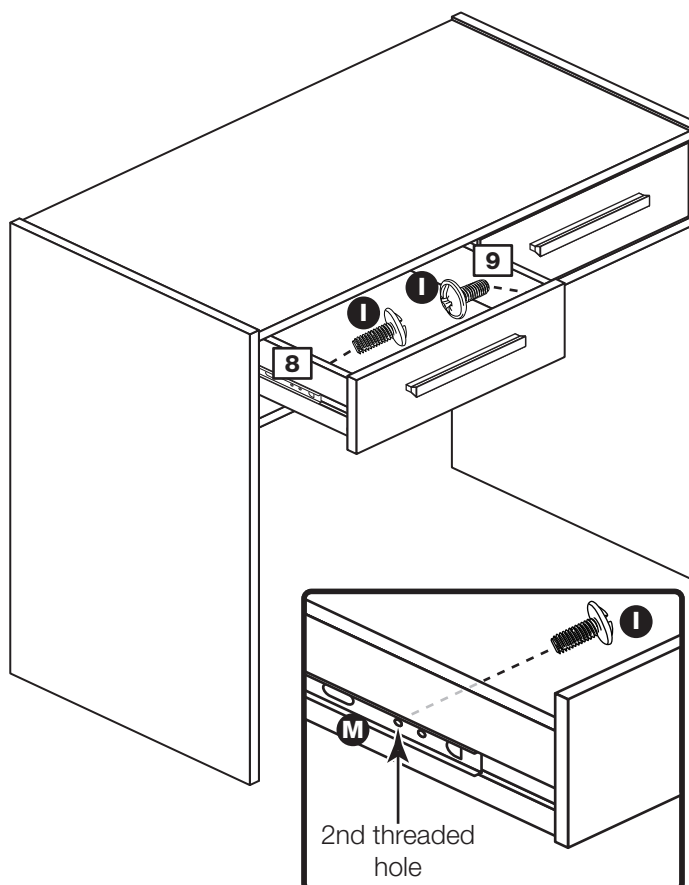

# Assembly Instructions

## Step 21

### Fit the bracket

To prevent possible overbalancing we recommend that this unit is secured to a suitable wall using the bracket **K**, fitted just below the modesty, on one of the side panels with the screw **H**.

Fixings are not supplied as they will need to suit the wall type, and the length of screw will depend on the distance of the back of the unit to the wall.

Warning: Take care when drilling the wall that you do not drill into any pipes, wires etc. If in doubt, consult an expert.

**The assembly of the dresser is complete**

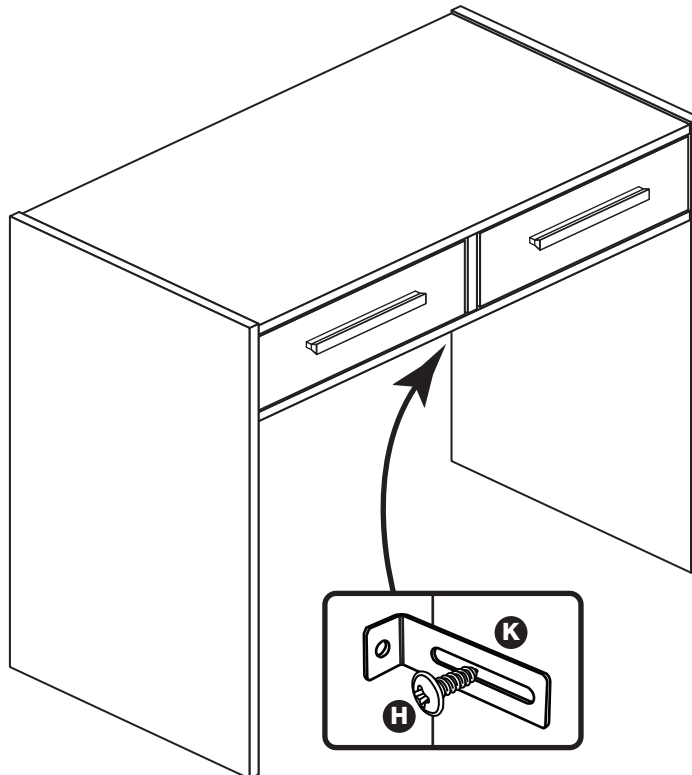

The Bracket can be fitted to either the Left Side or the Right Side.

# Assembly Instructions

## Step 22

### Prepare the 2 stool sides

Screw 6 metal dowels **B** into each of the 2 stool sides **12**, as shown.

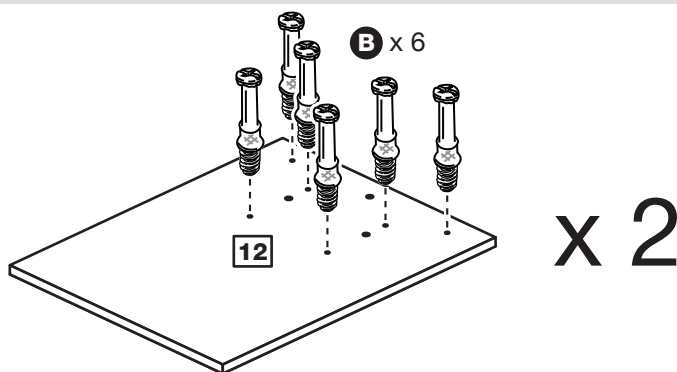

## Step 23

### Prepare the stool base

Insert 4 large locking nuts **D** into the holes in the stool base **13**.

Tap 2 wooden dowels **A** into the ends of the stool base **13**.

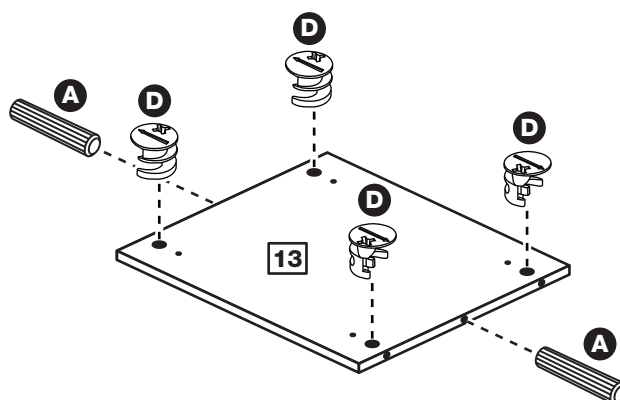

## Step 24

### Fit a stool side to the stool base

Fit one of the stool sides **12** to the stool base **13**.

Use a screwdriver to tighten the 2 large locking nuts **D** fitted to the stool base **13**.

**Note:** Turn the large locking nuts **D** as far as they will go - more than 1/2 a turn.

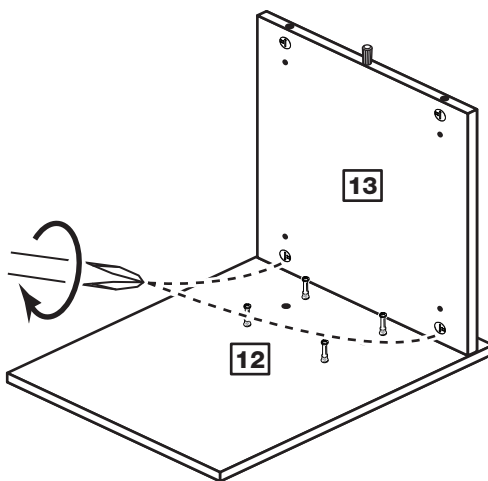

## Step 25

### Prepare the 2 stool rails

Insert 4 large locking nuts **D** into each of the 2 stool rails **14**.

Tap 2 wooden dowels **A** into each stool rail **14**.

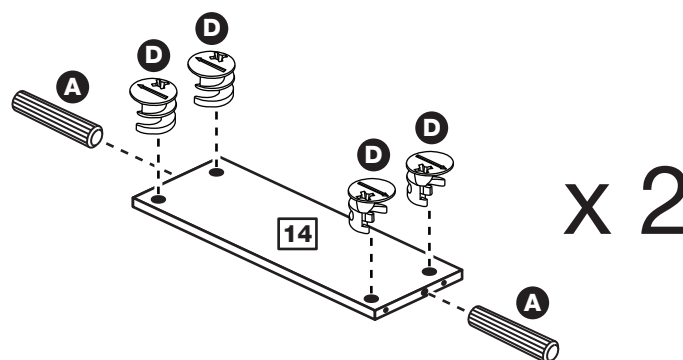

# Assembly Instructions

## Step 26

### Fit the 2 stool rails

Push the 2 stool rails **14** down onto the stool side **12**, as shown.

Use a screwdriver to tighten the 2 large locking nuts **D** fitted to each stool rail **14**.

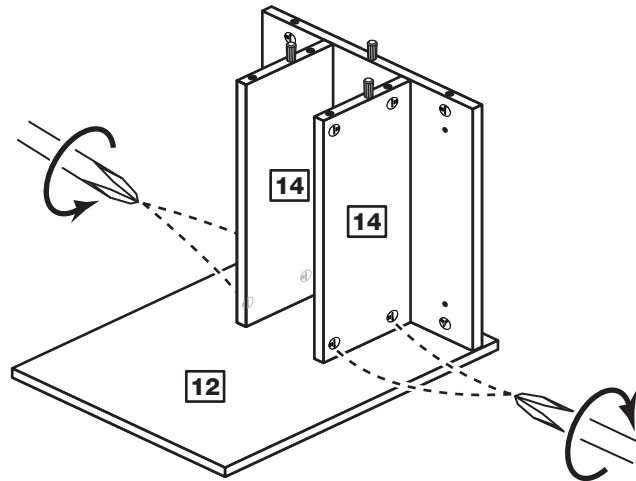

## Step 27

### Fit the other stool side

**a:** Push the other stool side **12** down onto the assembly, as shown.

Use a screwdriver to tighten the 2 large locking nuts **D** fitted to the stool base **13**.

**b:** Use a screwdriver to tighten the 2 large locking nuts **D** fitted to each of the stool rails **14**.

**a:**

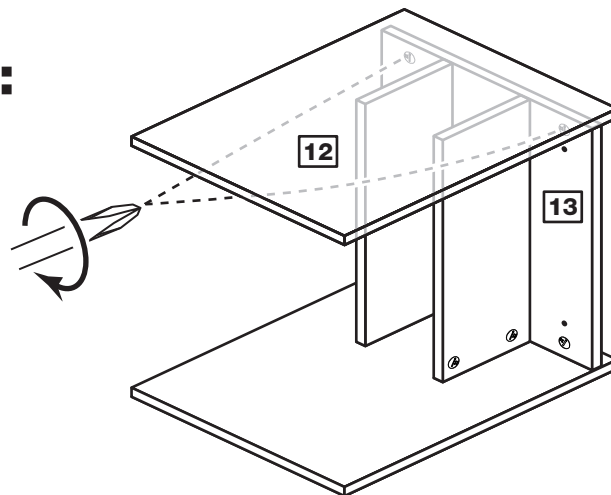

**b:**

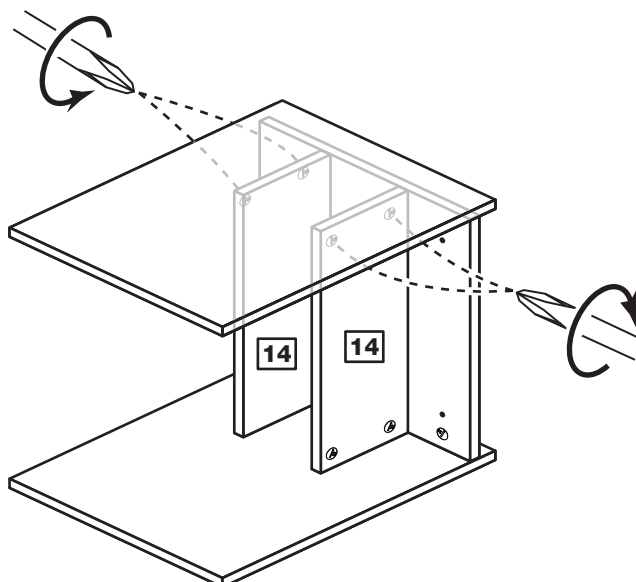

# Assembly Instructions

## Step 28

### Fit the seat pad

Position the seat pad **15** onto the assembly and make sure that its 4 edges line up with the stool base **13**.

Hold the seat pad **15** in position and screw up through the 4 holes in the stool base **13** using screws **G**.

**Note:** Make sure that you screw into the hard surface of the seat pad.

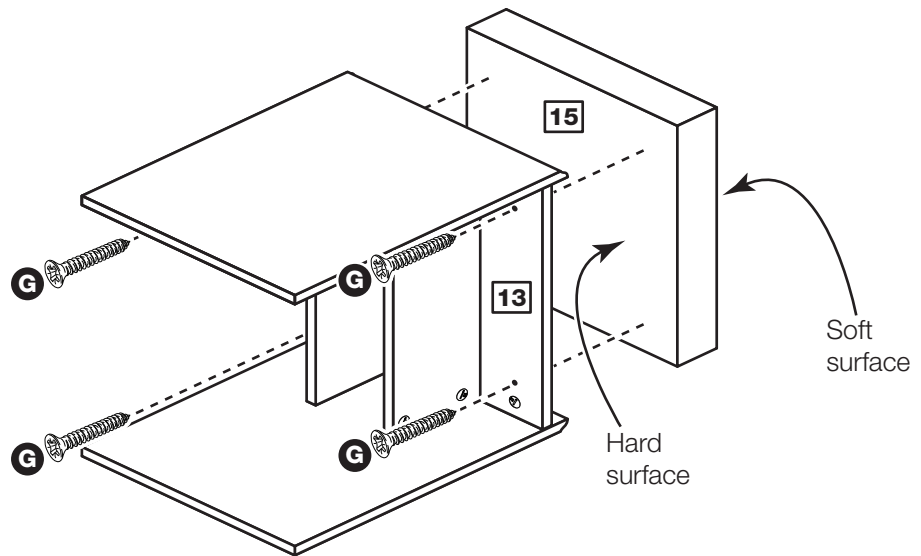

## Step 29

### Fit the plastic nails

Tap 2 plastic nails **O** into the bottom edge of each of the stool sides **12** as shown.

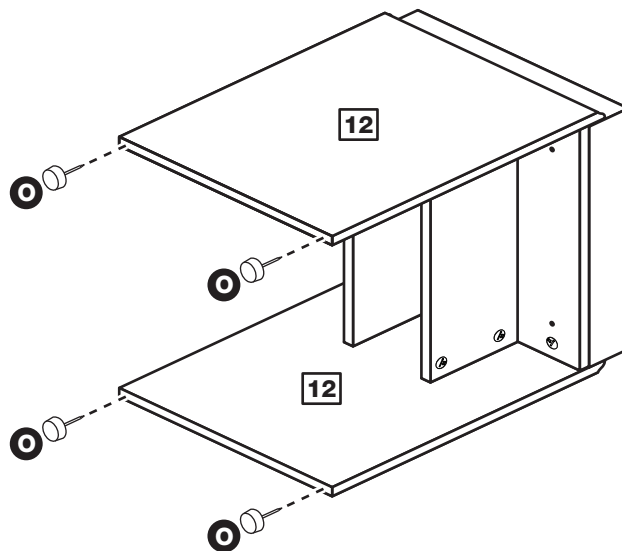

# Assembly Instructions

## Step 30

**Assembly is complete**

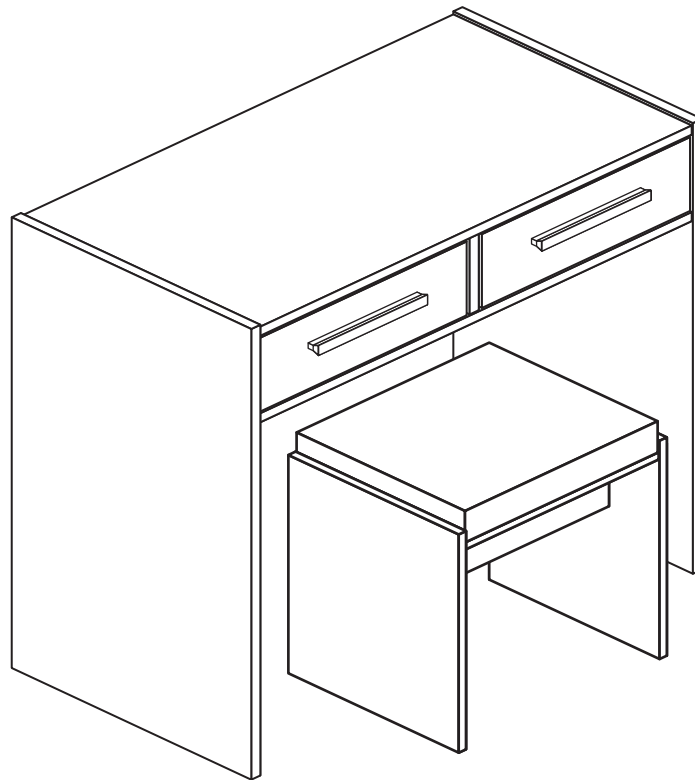

If you need help or have damaged or missing parts, call the **Customer Helpline: 08456 400800** and quote the reference numbers on the component pages.

Argos Ltd, 489-499 Avebury Boulevard, Central Milton Keynes, MK9 2NW







# New Sywell - Dresser and Stool

Assembly Instructions - Please keep for future reference

239/6994

259/7975

247/9684

258/7040

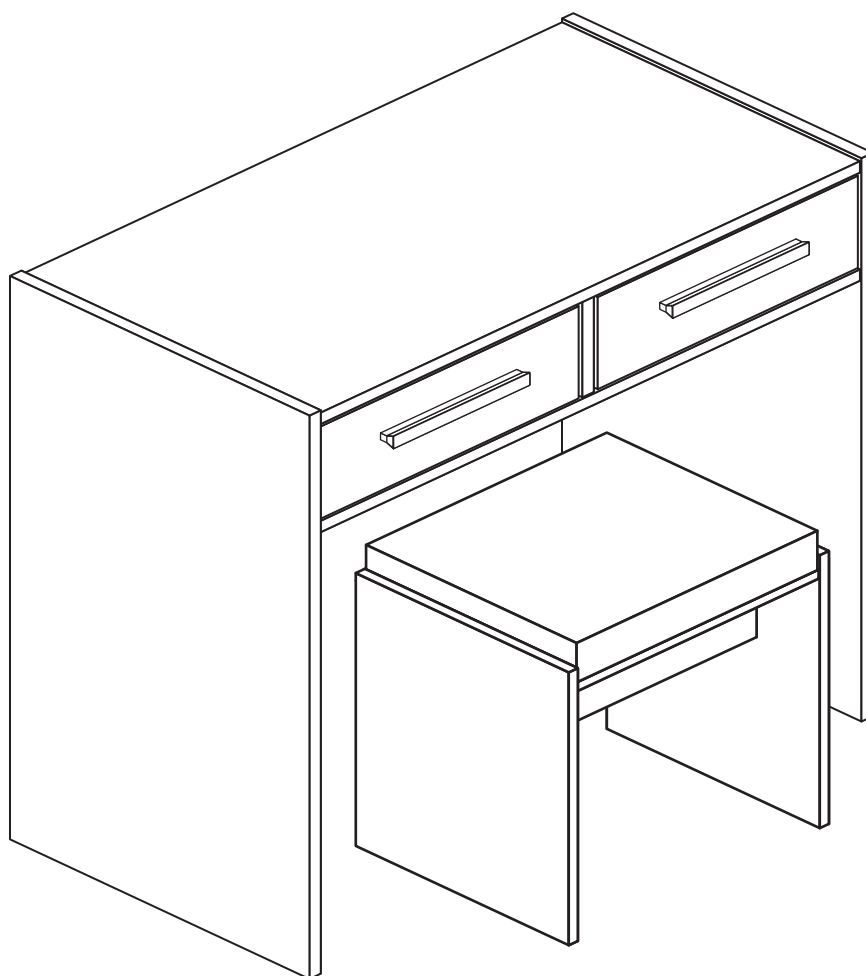

## Dresser Dimensions

Width - 77.5cm

Depth - 40cm

Height - 74.5cm

## Stool Dimensions

Width - 43cm

Depth - 35.5cm

Height - 48cm



**MADE IN  
BRITAIN**

**Important** - Please read these instructions fully before starting assembly

If you need help or have damaged or missing parts, call the **Customer Helpline: 03456 400800**



# Safety and Care Advice

**Important - Please read these instructions fully before starting assembly**

- **Warning:** This unit weighs approximately 24kgs. Please lift with care.

- Check you have all the components and tools listed on pages 2 and 3.

- Remove all fittings from the plastic bags and separate them into their groups.

- Keep children and animals away from the work area, small parts could choke if swallowed.

- Parts of the assembly will be easier with 2 people.

- Make sure you have enough space to layout the parts before starting.

- Do not stand or put weight on the product, this could cause damage.

- Assemble the item as close to its final position (in the same room) as possible.

- Assemble on a soft level surface to avoid damaging the unit or your floor (use opened out unit carton).



- We do not recommend the use of power drill/drivers **for inserting screws**, as this could damage the unit. Only use hand screwdrivers.

- **Safety note:** It is recommended that this unit is secured to a wall using the bracket supplied.

- Dispose of all packaging carefully and responsibly.

## Care and maintenance

- Only clean using a damp cloth and mild detergent, do not use bleach or abrasive cleaners.

- From time to time check that there are no loose screws on this unit.

- This product should not be discarded with household waste. Take to your local authority waste disposal centre.

**Note:** If required the next page can be cut out and used as reference throughout the assembly. Keep this page with these instructions for future reference.

# Components - Panels

If you have damaged or missing components, call the **Customer Helpline: 03456 400800** quoting the reference numbers below

Please check you have all the panels listed below

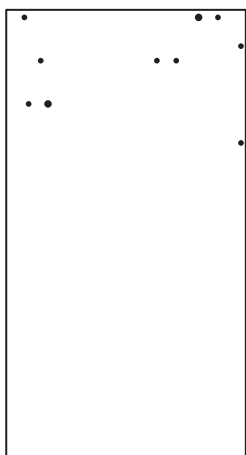

**1** Left Side (DF745)  
(745 x 396mm)

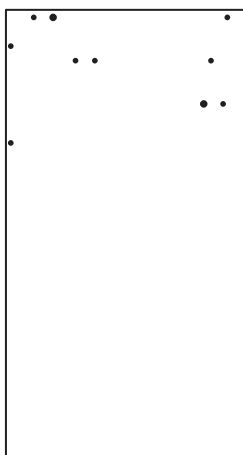

**2** Right Side (DF746)  
(745 x 396mm)

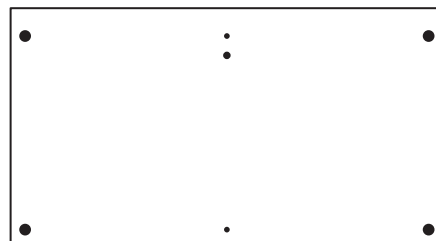

**3** Top (DF1348)  
(745 x 396mm)

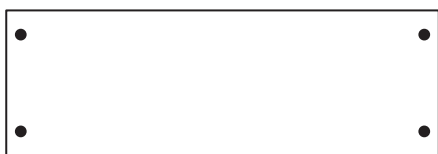

**4** Modesty (DF748)  
(715 x 243mm)

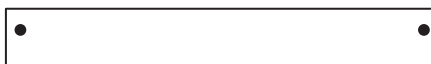

**5** Rail (DF753)  
(715 x 97mm)

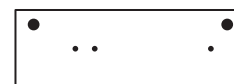

**6** Divider (DF887)  
(128 x 376mm)

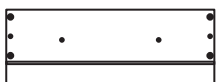

**7** Drawer Front (DF888)  
(344 x 122mm) x 2

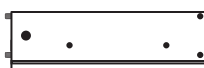

**8** Left Drawer Side (W516GLH)  
(320 x 95mm) x 2

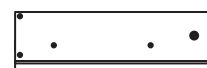

**9** Right Drawer Side (W516GRH)  
(320 x 95mm) x 2



**10** Drawer Back (W317-95)  
(317 x 95mm) x 2



**11** Drawer Base (T328-317)  
(328 x 317mm) x 2

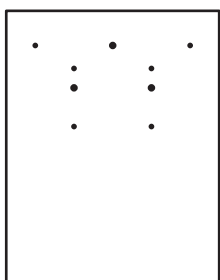

**12** Stool Side (D0996A)  
(451 x 352mm) x 2

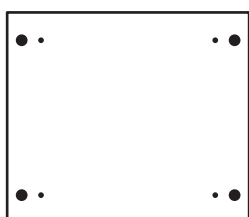

**13** Stool Base (D0997A)  
(400 x 348mm)



**14** Stool Rail (D0998A)  
(400 x 144mm) x 2



**15** Seat Pad (FMANPAD)  
(398 x 348mm)











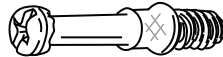





# Components - Fittings

If you have damaged or missing components, call the **Customer Helpline: 03456 400800** quoting the reference numbers below

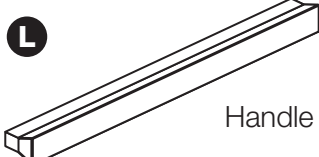
Please check you have all the fittings listed below

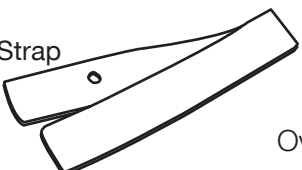
**Note:** The quantities below are the correct amount to complete the assembly. In some cases more fittings may be supplied than are required.

<p><b>A</b> </p> <p>Wooden dowel (F22) x 11</p>	<p><b>B</b> </p> <p>Metal dowel (F901) x 28</p>	<p><b>C</b> </p> <p>Knock-in Peg (F171) x 8</p>
<p><b>D</b> </p> <p>Large locking nut (F900) x 24</p>	<p><b>E</b> </p> <p>Small locking nut (F3) x 4</p>	<p><b>F</b> </p> <p>25mm Screw (F95) x 4</p>
<p><b>G</b> </p> <p>25mm Screw (F50) x 4</p>	<p><b>H</b> </p> <p>Wedgefix (F639) x 4</p>	<p><b>I</b> </p> <p>9mm Screw (F74) x 4</p>
<p><b>J</b> </p> <p>9mm Screw (F73) x 8</p>	<p><b>K</b> </p> <p>Plastic Nail (F91) x 8</p>	<p><b>L</b> </p> <p>Handle (F315) x 2</p>
<p><b>M</b> </p> <p>Drawer runner (F1004) x 4</p>		
<p><b>N</b>   Screw  Washer x 2</p> <p>Overbalance protector kit (F269) x 1</p>		

## Tools required



Rule



Cross-head screwdriver



Scissors



Hammer



Eye protection (when using a hammer or drill)



Electric drill (do not use for fitting screws)

Ruler - Use this ruler to help correctly identify the screws

mm 10 20 30 40 50 60 70 80 90 100 110 120 130 140 150 160 170

# Assembly Instructions

If you have damaged or missing components, call the  
**Customer Helpline: 03456 400800** quoting the reference  
numbers below

## Step 1

### Prepare the 2 drawer fronts

Screw 2 metal dowels **B** into each of the 2 drawer fronts **7**.

**Note:** Tighten the metal dowels up fully against the panels.

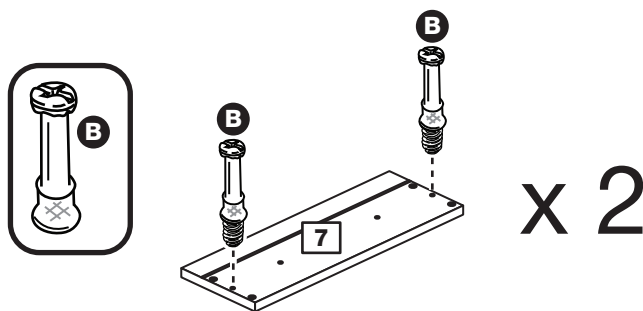

## Step 2

### Prepare the drawer sides

Insert a small locking nut **E** into the hole shown on the left drawer side **8** and the right drawer side **9**.

**Note:** The arrow on the locking nut **must** point towards the hole in the edge of the panel.

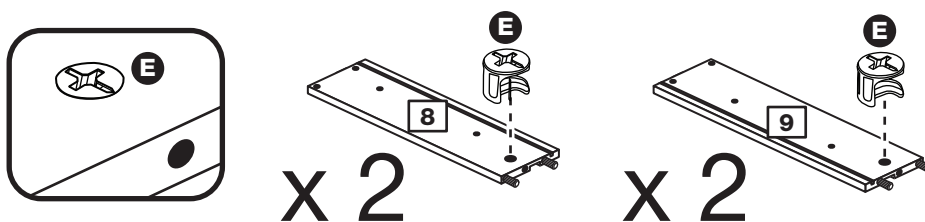

## Step 3

### Attach the drawer sides to the drawer fronts

Push the left drawer sides **8** and right drawer sides **9** onto the back of the drawer fronts **7**.

Turn the small locking nuts **E** on the left drawer side **8** and right drawer side **9**.

**Note:** Turn the locking nuts **E** clockwise to secure panels - more than 1/2 a turn.

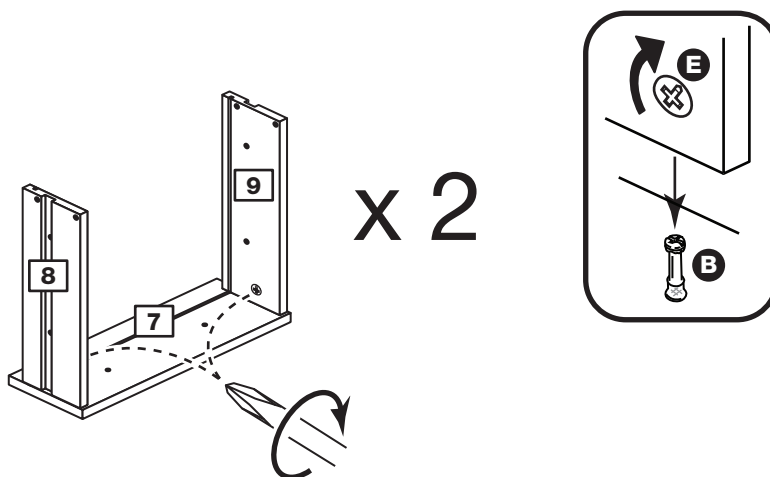

# Assembly Instructions

## Step 4

### Fit the drawer bases

Slide the drawer base **11** down the grooves in the drawer sides **8** and **9** and down into the groove in the drawer front **7**.

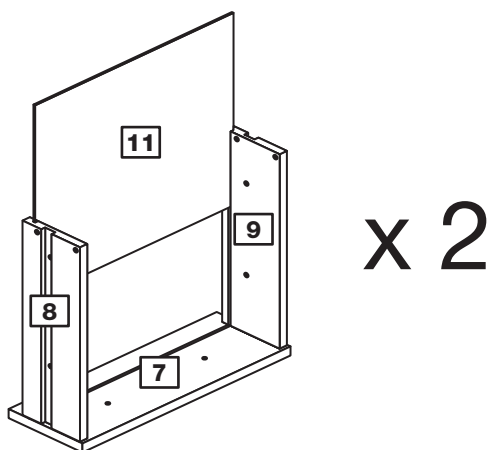

## Step 5

### Fit the drawer backs

Fit the drawer back **10** between the drawer sides **8** and **9**. Make sure that the drawer base **11** fits into the groove in the drawer back **10**.

Hold the drawer back **10** in position and tap the knock-in pegs **C** through the holes in the drawer sides **8** and **9**.

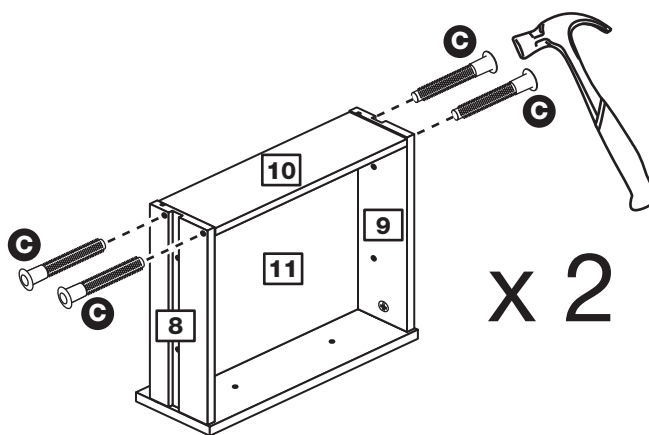

## Step 6

### Attach the handles

Attach a handle **L** to each drawer front **7** using 2 screws **F**.

**Note: Do not overtighten the screw.**

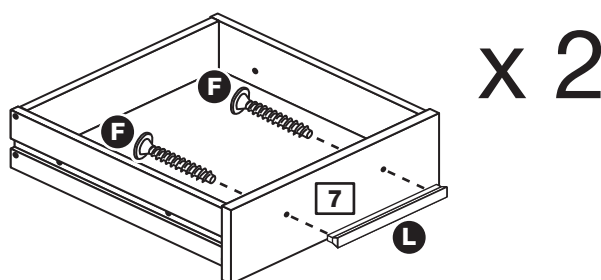

## Step 7

### Fit the wedgifixes

Turn the drawer assemblies over and slide 2 wedgifixes **H** into the front and back grooves, as shown, and tighten up the screws.

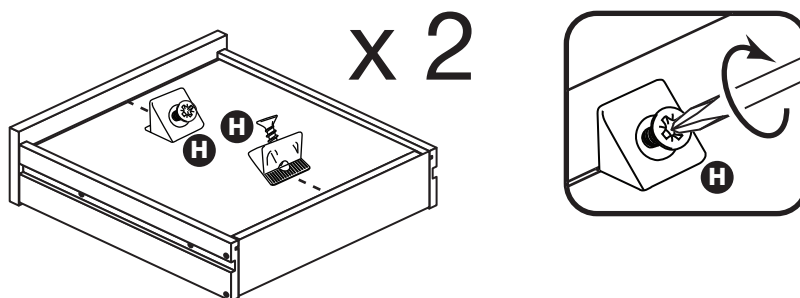

# Assembly Instructions

## Step 8

### Prepare the left side

**a:** Place a runner **M** on the left side **1**. Slide back the top of the runner and use the 2nd hole from the front to fit the 1st screw **J**.

**b:** Slide the runner back the other way and fit the 2nd screw **J** into the corresponding hole in the left side **1**.

**c:** Screw 5 metal dowels **B** into the left side **1**.

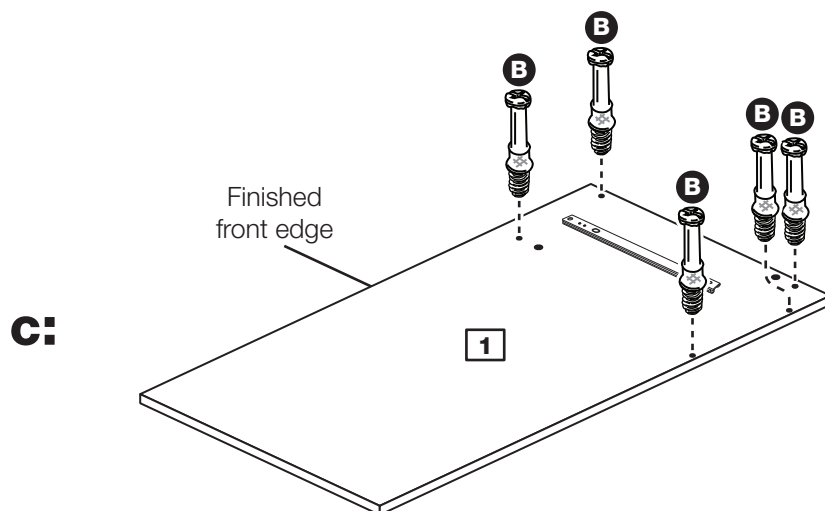
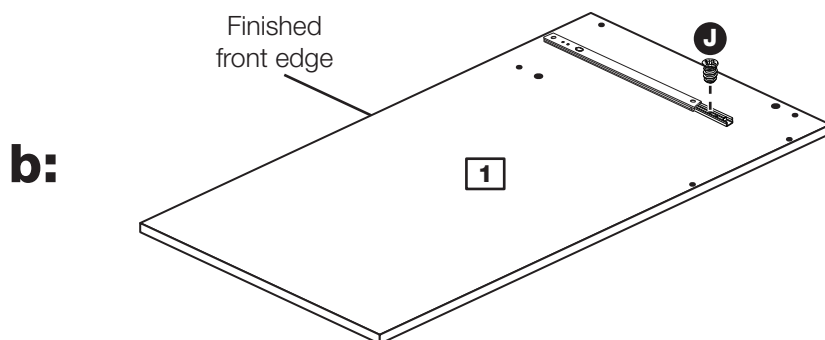
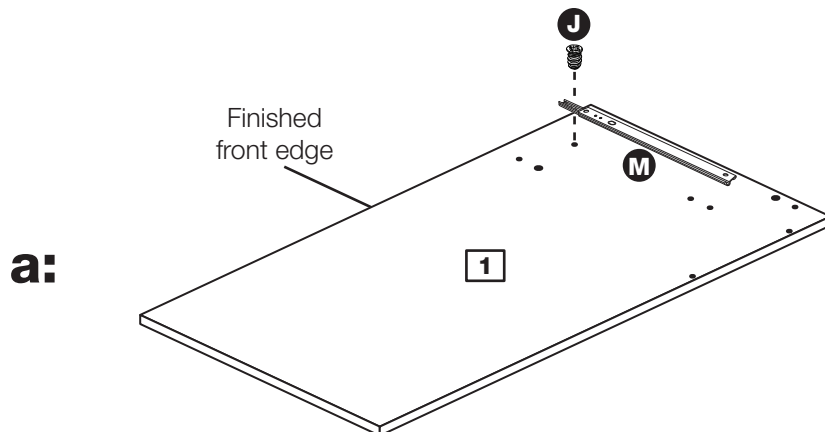
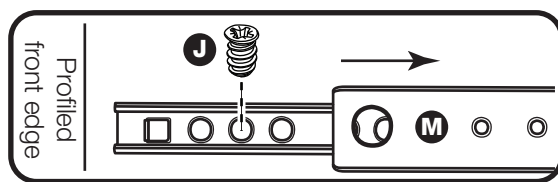

# Assembly Instructions

## Step 9

### Prepare the right side

**a:** Place a runner **M** on the right side **2**. Slide back the top of runner and use the 2nd hole from the front to fit the 1st screw **J**.

**b:** Slide the runner **M** back the other way and fit the 2nd screw **J** into the corresponding hole on the right side **2**.

**c:** Screw 5 metal dowels **B** into the right side **2**.

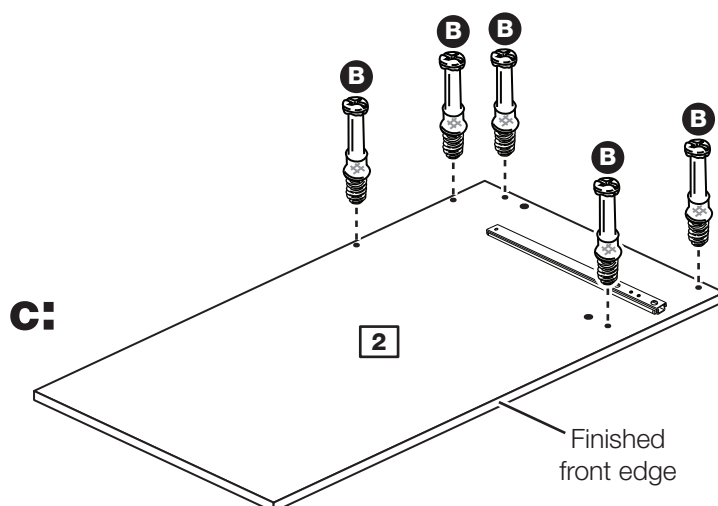
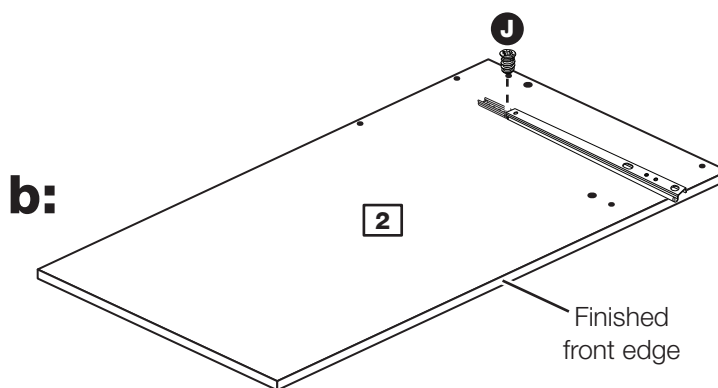
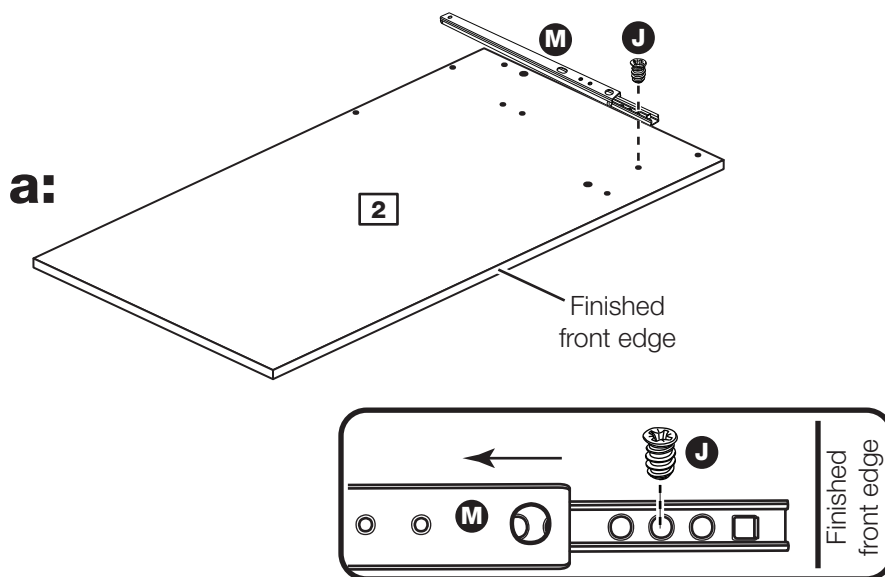



# Assembly Instructions

## Step 10

### Prepare the top

Tap 2 wooden dowels **A** into the top **3**.

**Note:** Wooden dowels **must not** stick out from the edge by more than 10mm or they may damage other panels.

Screw 2 metal dowels **B** into the top **3**.

Insert 4 large locking nuts **D** into the top **3**.

**Note:** The arrow on the locking nut **must** point towards the hole in the edge of the panel.

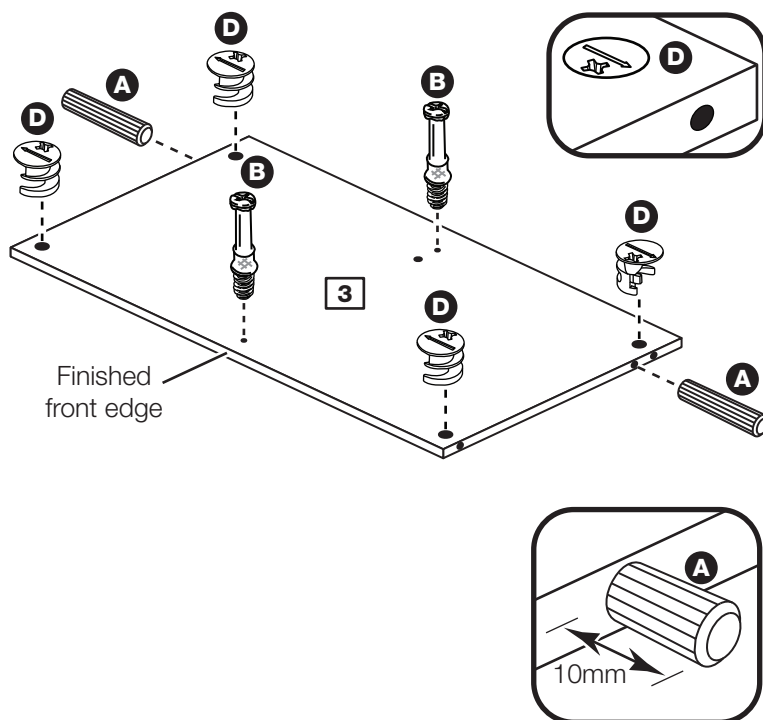

## Step 11

### Fit the top

Push the top **3** onto the right side **2**.

Use a screwdriver to tighten the 2 large locking nuts **D** fitted to the right side **2**.

**Note:** Turn the large locking nuts **D** as far as they will go - more than 1/2 a turn.

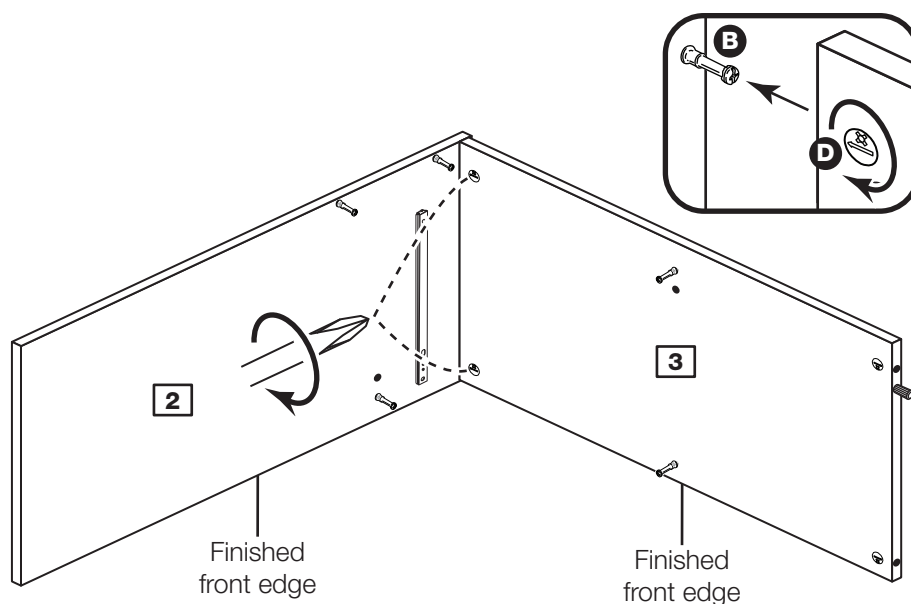

# Assembly Instructions

## Step 12

### Prepare the divider

**a:** Place a runner **M** on the divider **6** as shown. Slide back the top of runner and use the 2nd hole from the front to fit the 1st screw **J**.

**b:** Slide the runner **M** back the other way and fit the 2nd screw **J** into the corresponding hole in the divider **6**.

Tap a wooden dowel **A** into the divider **6**.

Insert 2 large locking nuts **D** into the divider **6**.

### Turn the divider over

**c:** Place a runner **M** on the divider **6** as shown. Slide back the top of runner and use the 2nd hole from the front to fit the 1st screw **J**.

**d:** Slide the runner **M** back the other way and fit the 2nd screw **J** into the corresponding hole in the divider **6**.

**Note:** Due to the manufacturing process, the 2 holes for the large locking nut can be on either surface of the divider.

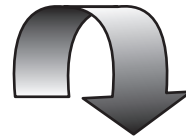
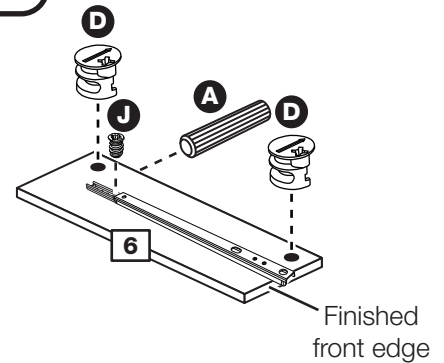
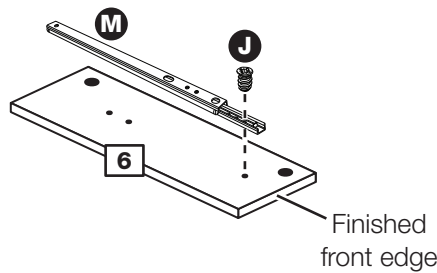
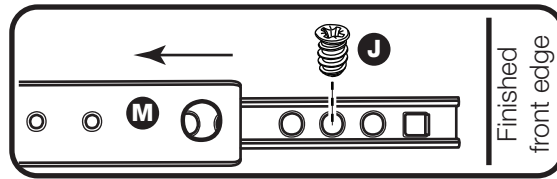

### Turn the divider over

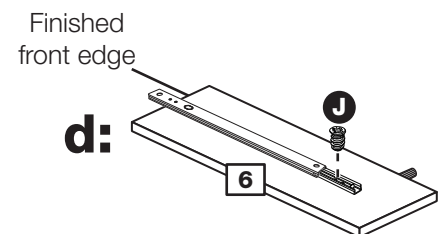
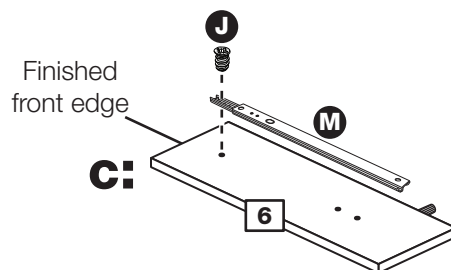
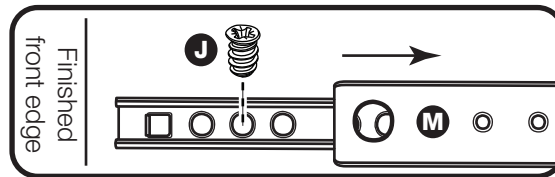

# Assembly Instructions

## Step 13

### Fit the divider

Push the divider **6** onto the top **3**.

Use a screwdriver to tighten the 2 large locking nuts **D** fitted to the divider **6**.

**Note:** The large locking nuts can be on either surface of the divider.

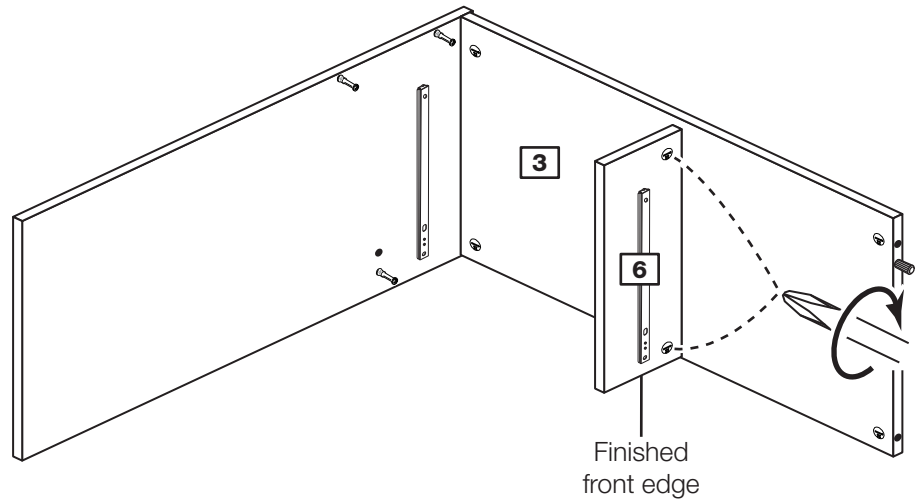

## Step 14

### Prepare the rail

Tap 2 wooden dowels **A** into the rail **5**.

Insert 2 large locking nuts **D** into the rail **5**.

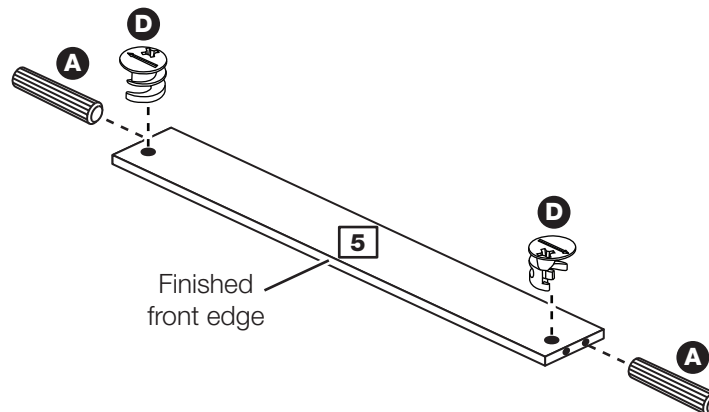

## Step 15

### Fit the rail

Push the rail **5** onto the right side **2**.

Use a screwdriver to tighten the large locking nut **D** fitted to the rail **5**.

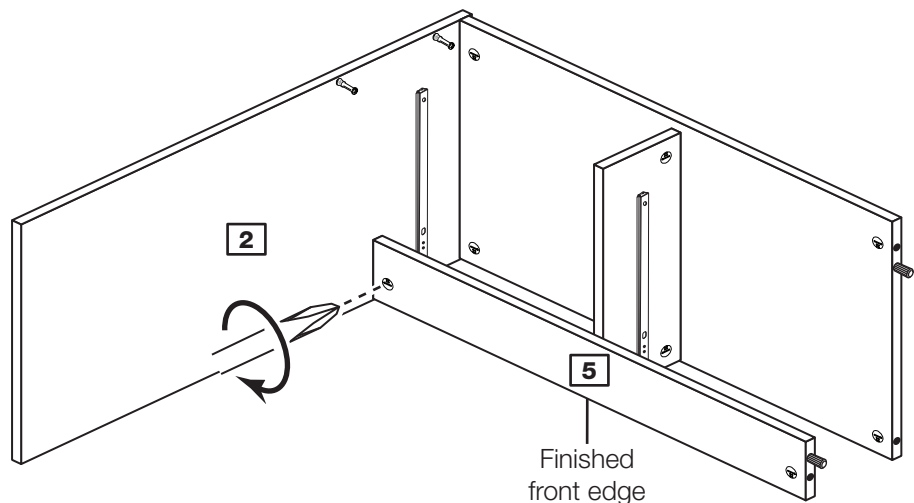

# Assembly Instructions

## Step 16

### Prepare the modesty

Insert 4 large locking nuts **D** into the modesty **4**.

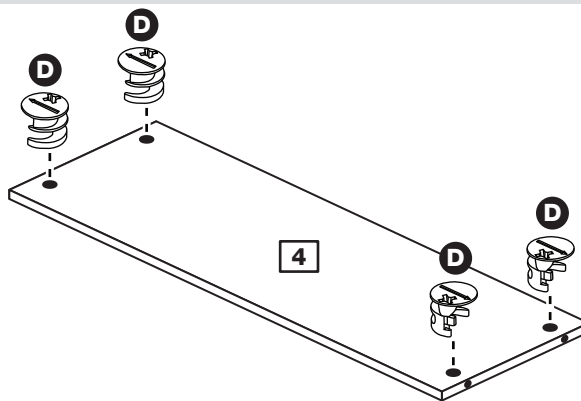

## Step 17

### Fit the rail

Push the modesty **4** onto the right side **2**.

Use a screwdriver to tighten the large locking nut **D** fitted to the modesty **4**.

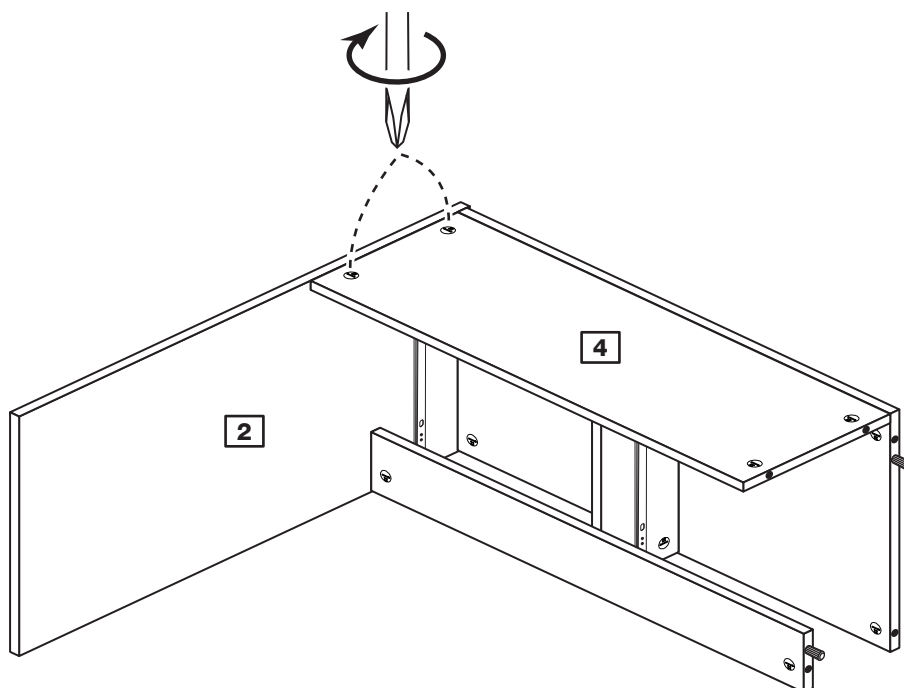

## Step 18

### Fit the left side

Push the left side **1** onto the assembly.

Use a screwdriver to tighten the 5 large locking nuts **D** fitted to the top **3**, modesty **4** and rail **5**.

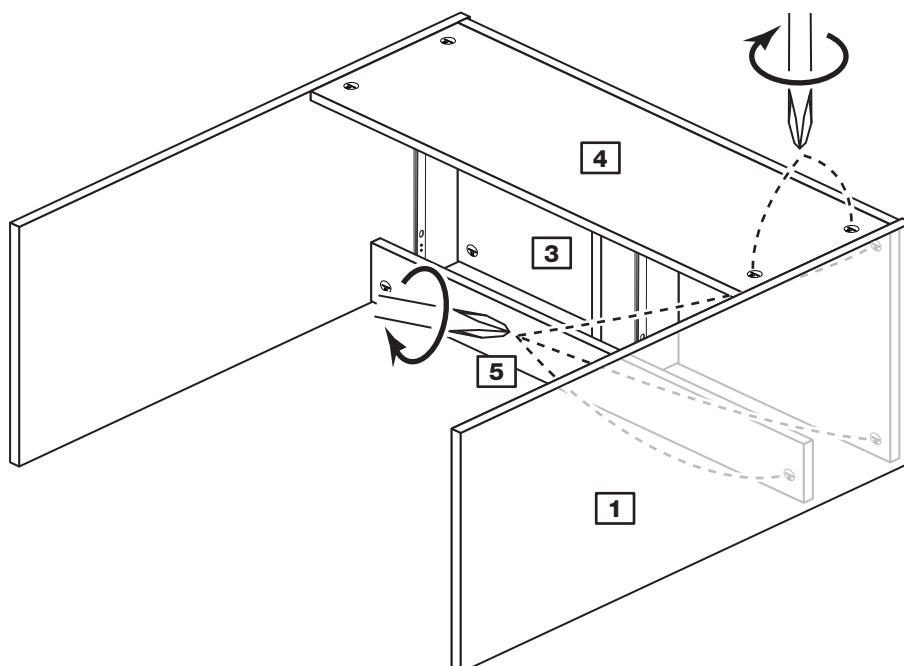

# Assembly Instructions

## Step 19

### Fit the plastic nails

Tap 2 plastic nails **K** into the bottom edge of each of the sides **1** and **2** as shown.

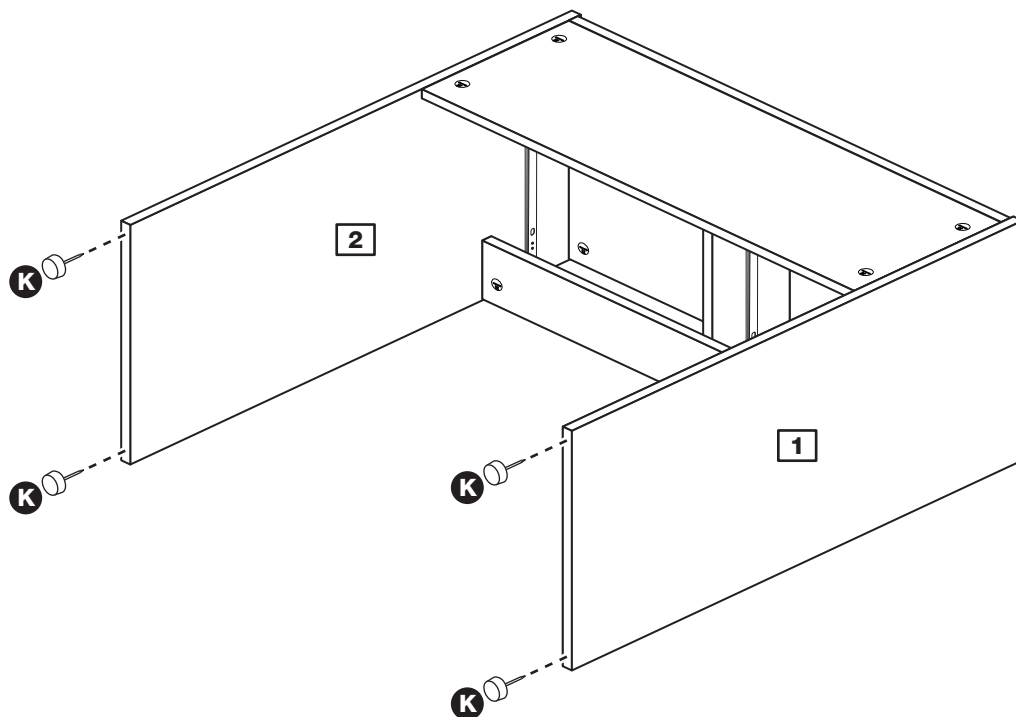

## Step 20

### Fit the drawers

Slide both of the runners **M** forward and locate the drawer sides **10** and **11** between them, lining up the holes in the drawer sides with the 2nd 'threaded' holes in the runners.

Working from the inside of the drawer, insert 2 screws **I** through the drawer sides and out into the 2nd threaded hole in the runner.

**Note:** Do not overtighten the screws.

If they catch on the runner you may need to loosen them slightly.

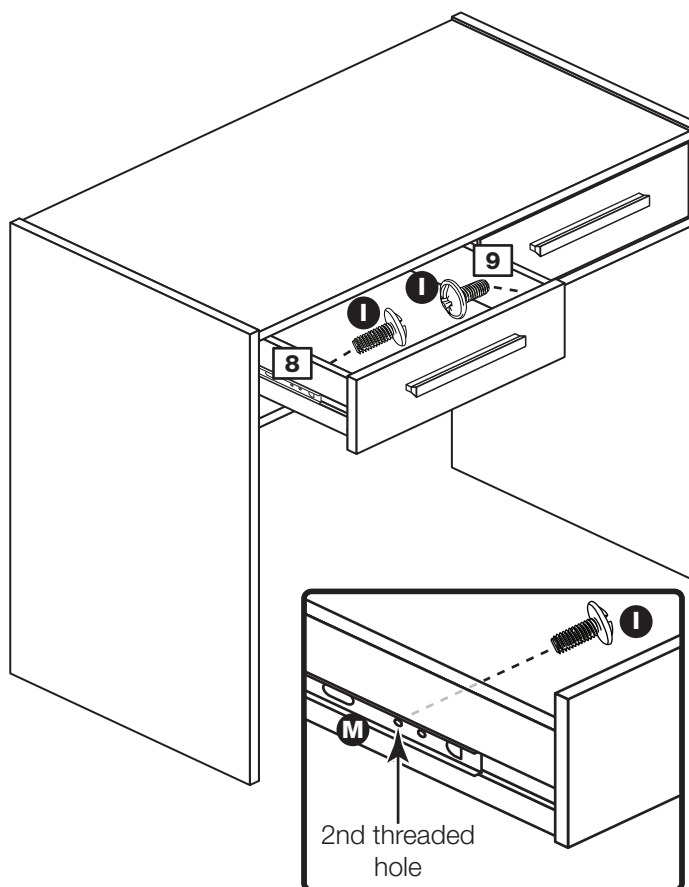

# Assembly Instructions

## Step 21

### Fit the overbalance protector kit

To prevent possible overbalancing we recommend that this unit is secured to a suitable wall by fitting of the overbalance protector kit **N** to the unit, or an alternative fixing method of your choice.

Wall fixings are not supplied as they will need to suit the wall type.

**Note:** Take care when drilling the wall that you do not drill into any pipes, wires etc. If in doubt, consult an expert.

**The assembly of the dresser is complete**

### Example

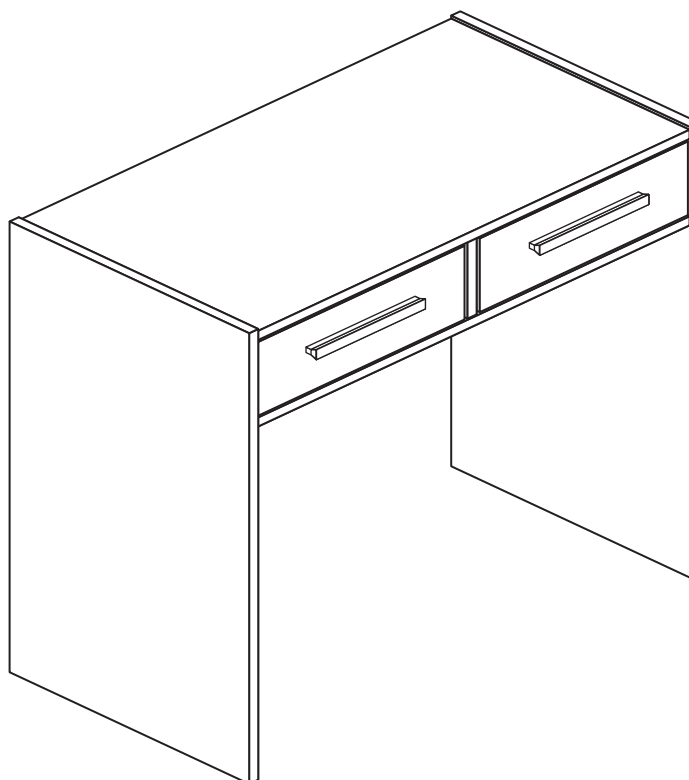
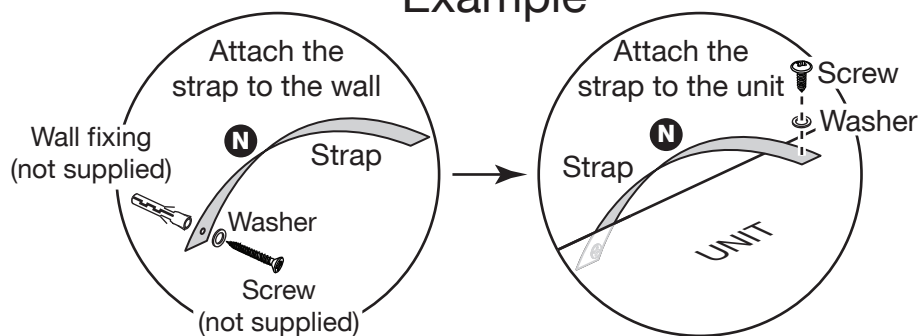

# Assembly Instructions

## Step 22

### Prepare the 2 stool sides

Screw 6 metal dowels **B** into each of the 2 stool sides **12**, as shown.

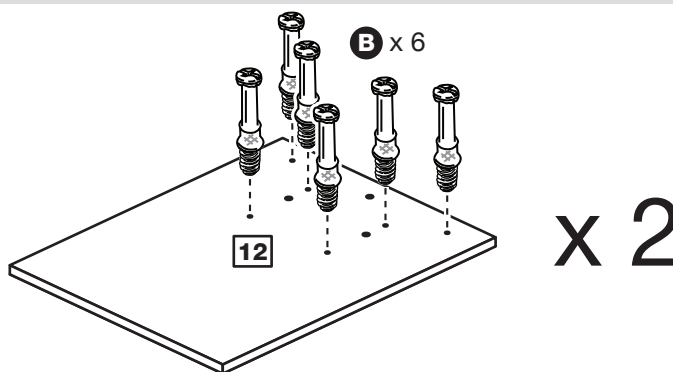

## Step 23

### Prepare the stool base

Insert 4 large locking nuts **D** into the holes in the stool base **13**.

Tap 2 wooden dowels **A** into the ends of the stool base **13**.

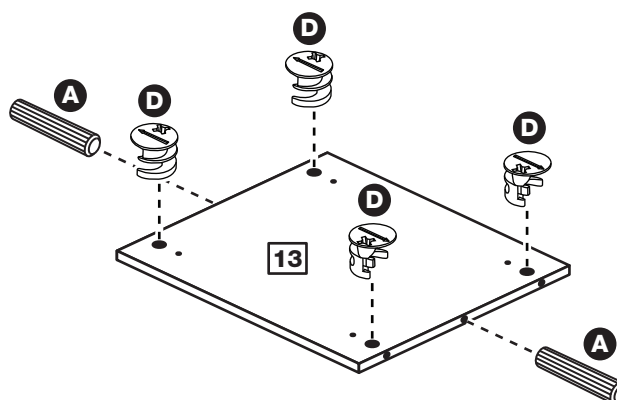

## Step 24

### Fit a stool side to the stool base

Fit one of the stool sides **12** to the stool base **13**.

Use a screwdriver to tighten the 2 large locking nuts **D** fitted to the stool base **13**.

**Note:** Turn the large locking nuts **D** as far as they will go - more than 1/2 a turn.

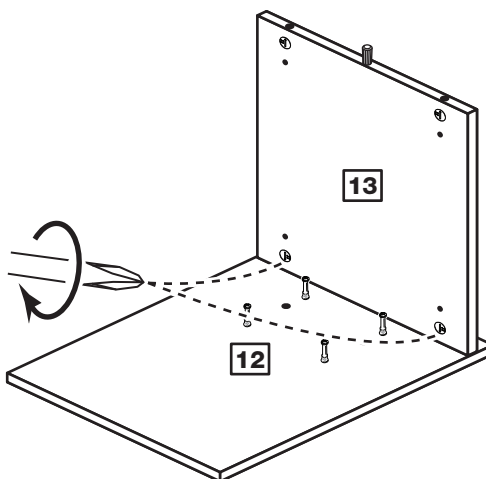

## Step 25

### Prepare the 2 stool rails

Insert 4 large locking nuts **D** into each of the 2 stool rails **14**.

Tap 2 wooden dowels **A** into each stool rail **14**.

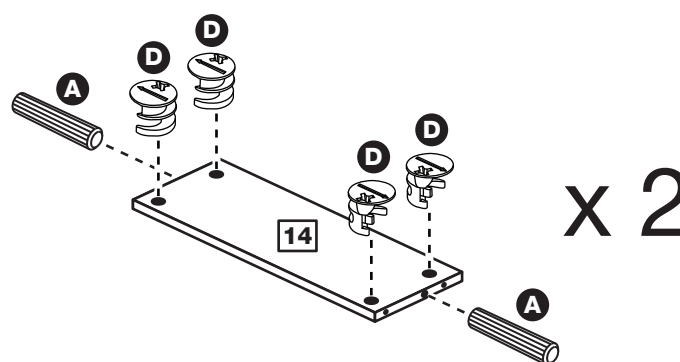

# Assembly Instructions

## Step 26

### Fit the 2 stool rails

Push the 2 stool rails **14** down onto the stool side **12**, as shown.

Use a screwdriver to tighten the 2 large locking nuts **D** fitted to each stool rail **14**.

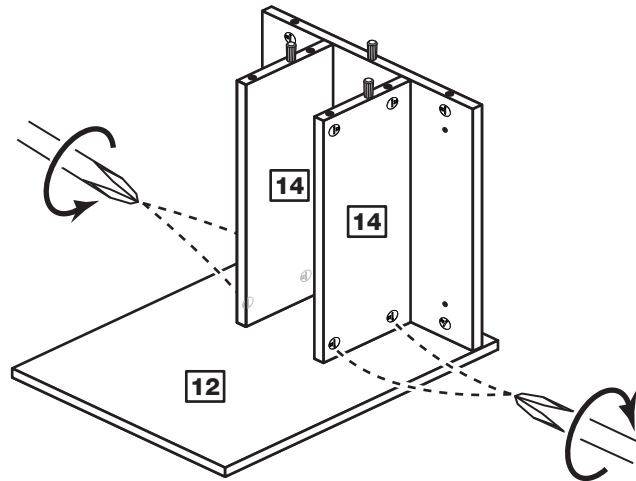

## Step 27

### Fit the other stool side

**a:** Push the other stool side **12** down onto the assembly, as shown.

Use a screwdriver to tighten the 2 large locking nuts **D** fitted to the stool base **13**.

**b:** Use a screwdriver to tighten the 2 large locking nuts **D** fitted to each of the stool rails **14**.

**a:**

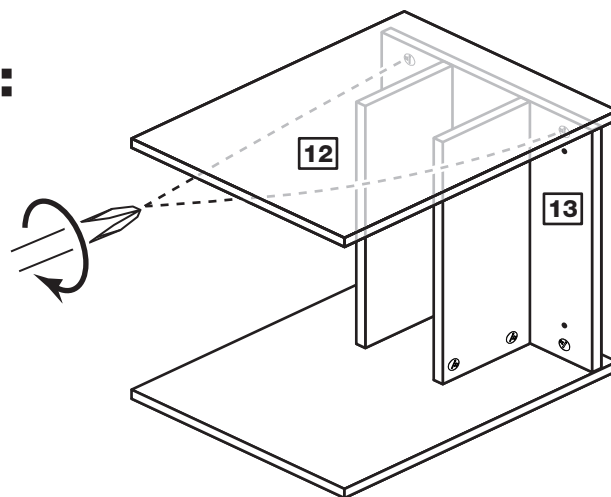

**b:**

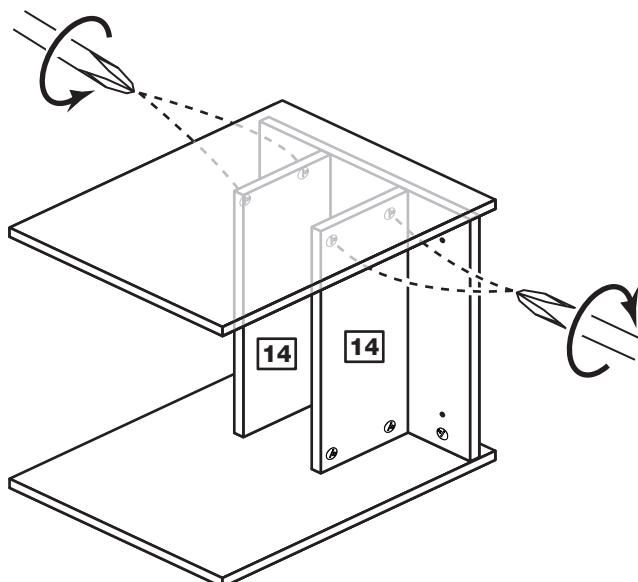



# Assembly Instructions

## Step 28

### Fit the seat pad

Position the seat pad **15** onto the assembly and make sure that its 4 edges line up with the stool base **13**.

Hold the seat pad **15** in position and screw up through the 4 holes in the stool base **13** using screws **G**.

**Note:** Make sure that you screw into the hard surface of the seat pad.

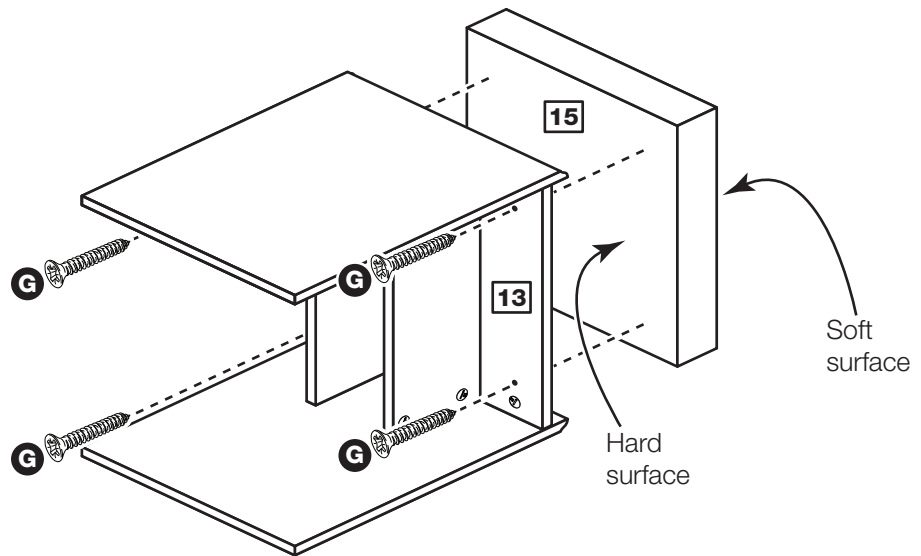

## Step 29

### Fit the plastic nails

Tap 2 plastic nails **K** into the bottom edge of each of the stool sides **12** as shown.

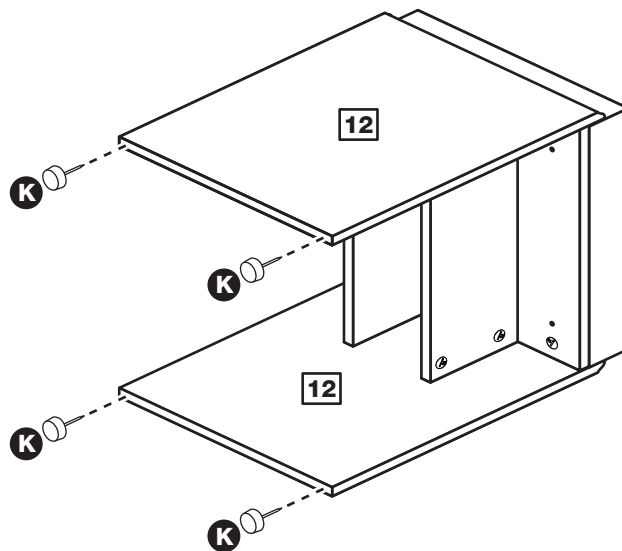

# Assembly Instructions

## Step 30

**Assembly is complete**

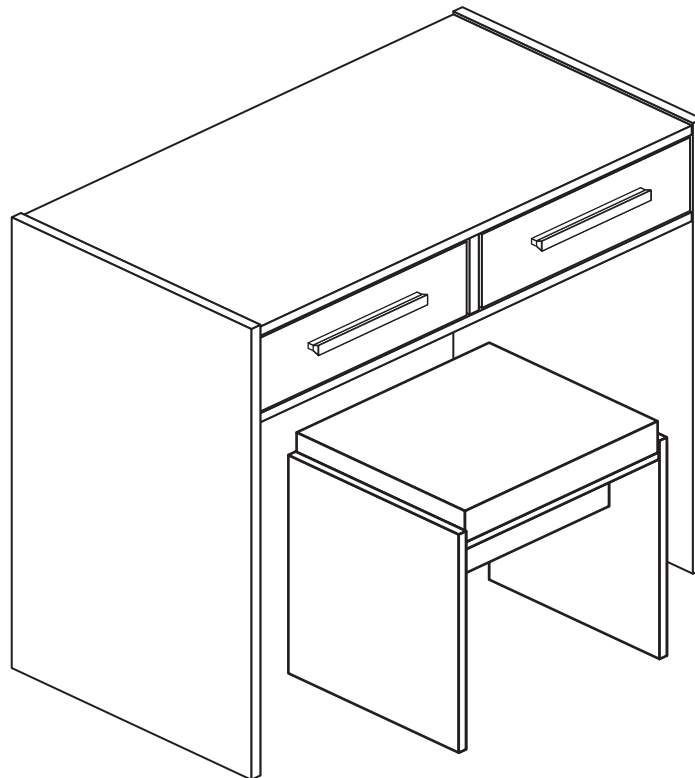

If you need help or have damaged or missing parts, call the **Customer Helpline: 03456 400800** and quote the reference numbers on the component pages.

Argos Ltd, 489-499 Avebury Boulevard, Central Milton Keynes, MK9 2NW



