

HOOVER

INSTRUCTION MANUAL



GENERATION FUTURE



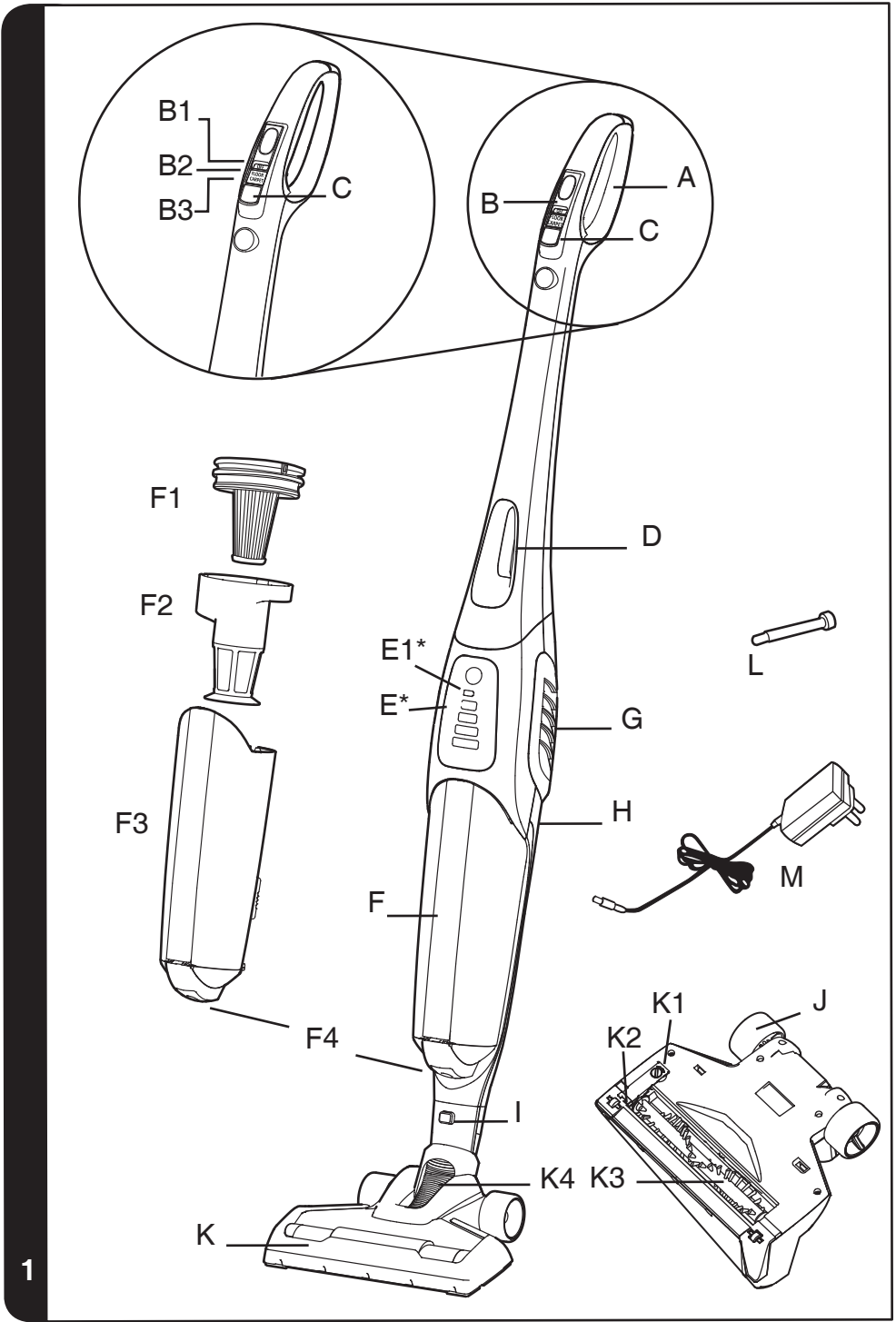

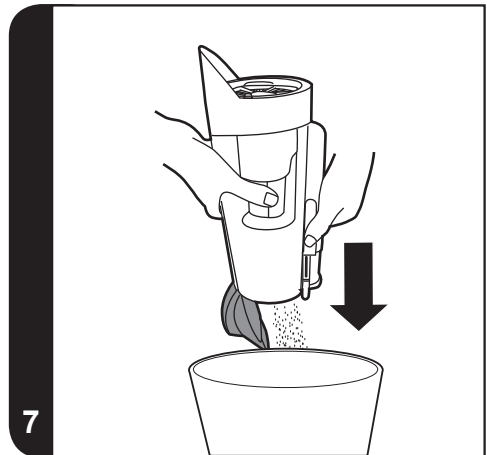
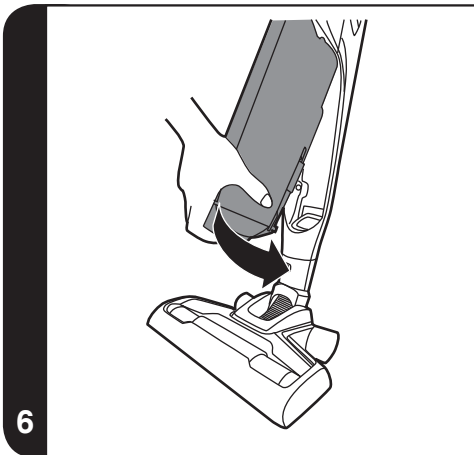
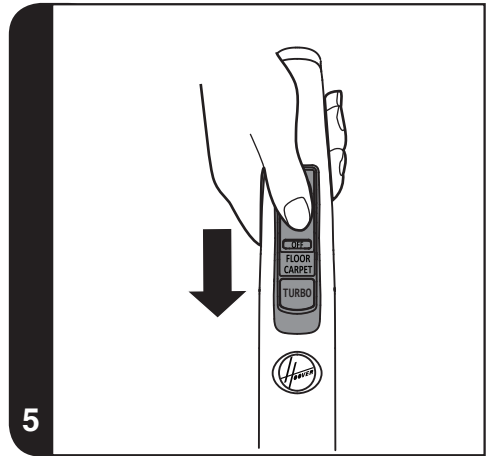
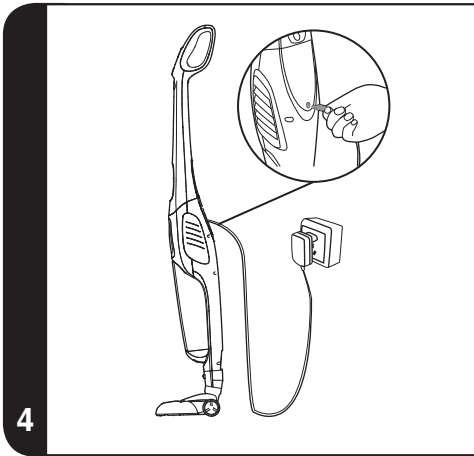
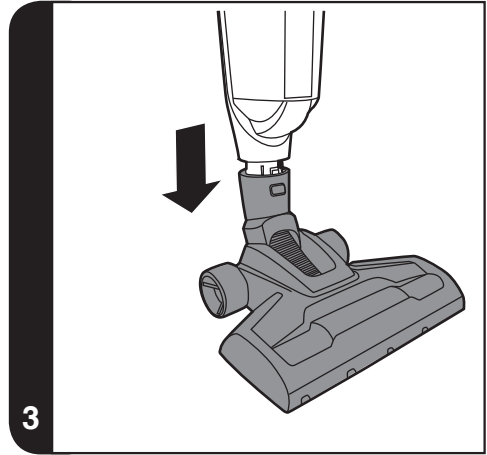
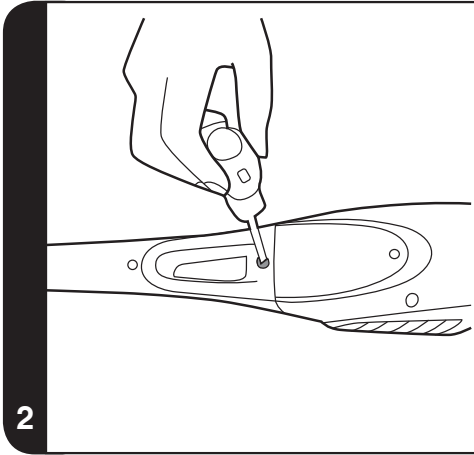

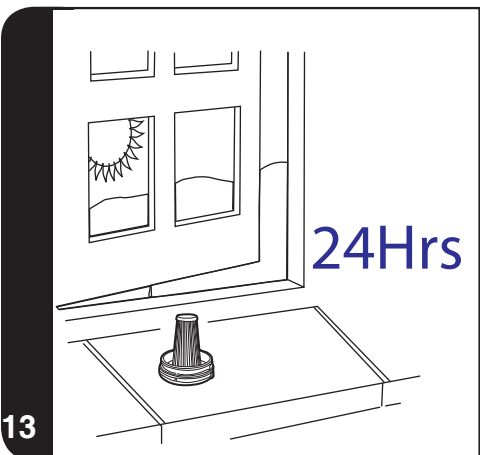
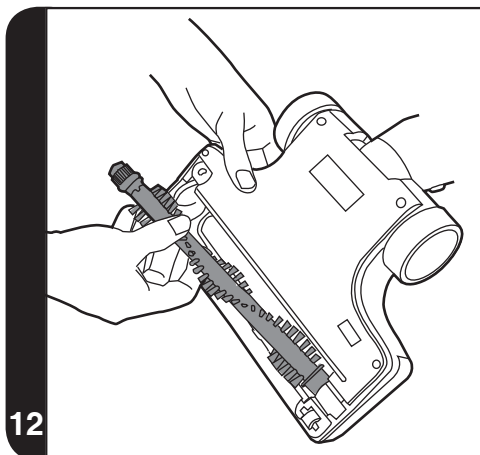
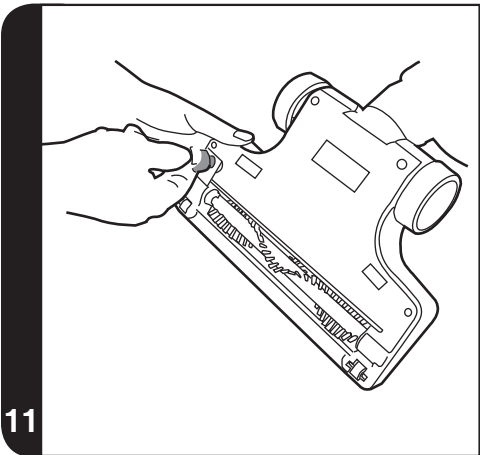
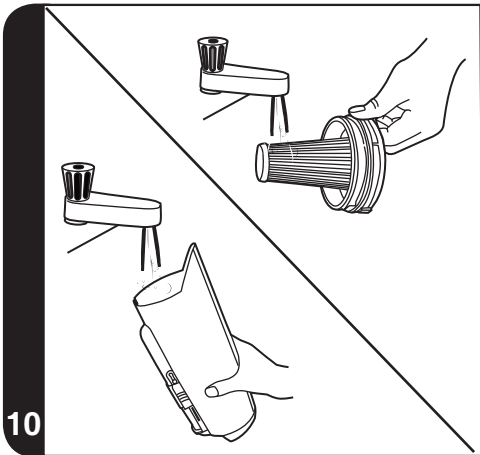
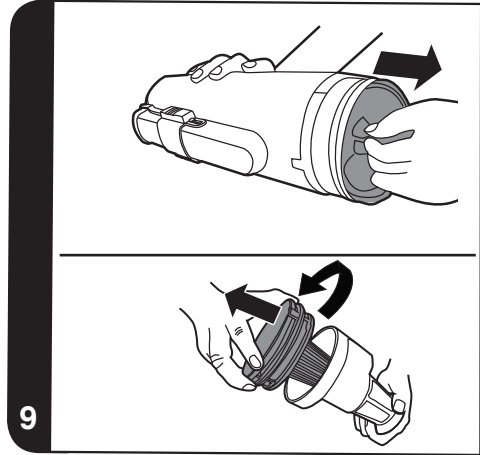
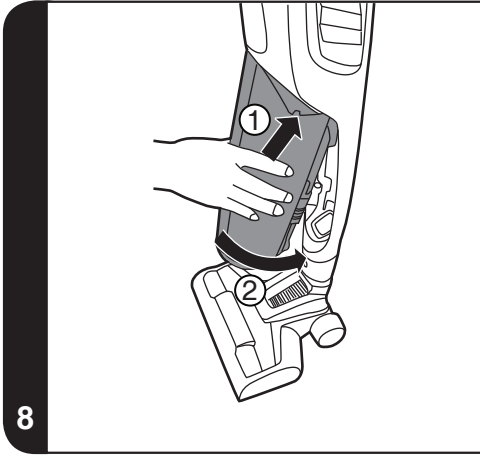

INSTRUCTIONS FOR SAFE USE

This appliance should only be used for domestic cleaning, as described in this user guide. Please ensure that this guide is fully understood before operating the appliance.

Always switch off and remove the charger from the socket before cleaning the appliance or any maintenance task.

This appliance can be used by children aged from 8 years and above and persons with reduced physical, sensory or mental capabilities or lack of experience and knowledge if they have been given supervision or instruction concerning use of the appliance in a safe way and understand the hazards involved. Children shall not play with the appliance. Cleaning and user maintenance shall not be made by children without supervision.

If the power cord is damaged stop using the appliance immediately. To avoid a safety hazard, an authorised Hoover service engineer must replace the power cord.

Keep hands, feet, loose clothing and hair away from rotating brushes.

Use only the original charger supplied with the appliance.

Check that your supply voltage is the same as that stated on the charger.

This appliance is supplied with a double insulated battery charger which is only suitable for insertion in a 230V (UK 240V) socket outlet.

Plug the charger in to suitable socket outlet and connect the power cord connector to the DC socket on the appliance. [4]

When charging the appliance, the power switch must be off.

Before first use, charge your appliance for 24 hours. The charge indicator will flash when charging.

Do plug in the charger after use to recharge the batteries.

It is normal for the charger to become warm to the touch when charging.

Do not unplug the charger by pulling on the power cord.

Unplug the charger in the event of prolonged absence (holidays, etc.). Recharge appliance again before use as batteries may self

discharge over increased periods of storage.

If the appliance is to be disposed of the batteries must first be removed. The appliance must be disconnected from the supply mains when removing the battery. Dispose of the batteries safely. Used batteries should be taken to a recycling station and not disposed of with household waste. To remove the batteries, please contact the Hoover Customer Centre or proceed according to the following instructions.

IMPORTANT: Always fully discharge the batteries before removal and ensure the charger is unplugged.

1. Run the cleaner until the batteries are completely empty.
2. Remove the ergonomic handle and the screws, in the main body to open the cleaner.
3. Remove the motor battery housing and disconnect the cables.
4. Remove the batteries from the housing.

NOTE: Should you experience any difficulty in dismantling the unit or for more detailed information on treatment, recovery and recycling of this appliance, please contact your local city office or your household waste disposal service.

DO NOT expose the batteries to a room temperature above 40°C.

Use only attachments, consumables or spares recommended or supplied by Hoover.

Static electricity: Some carpets can cause a small build up of static electricity. Any static discharge is not hazardous to health.

Do not use your appliance out of doors or on any wet surface or for wet pick up.

Do not pick up hard or sharp objects, matches, hot ashes, cigarette ends or other similar items.

Do not spray with or pick up flammable liquids, cleaning fluids, aerosols or their vapours.

Do not run over the power cord when using your appliance or remove the plug by pulling on the power cord.

Do not continue to use your appliance or charger if it appears faulty.

Hoover service: To ensure the continued safe and efficient operation of this appliance we recommend that any servicing or repairs are only carried out by an authorised Hoover service engineer.

Do not use the appliance to clean animals or people.

Do not replace the batteries with non-rechargeable batteries.

Do frequently clean the dust cup and filter assembly.

The Environment:

This appliance is marked according to the European directive 2011/65/EC on Waste Electrical and Electronic Equipment (WEEE). By ensuring this product is disposed of correctly, you will help prevent potential negative consequences for the environment and human health, which could otherwise be caused by inappropriate waste handling of this product. The symbol on the product indicates that this product may not be treated as household waste. Instead it shall be handed over to the applicable collection point for the recycling of electrical and electronic equipment. Disposal must be carried out in accordance with local environmental regulations for waste disposal. For more detailed information about treatment, recovery and recycling of this product, please contact your local city office, your household waste disposal service or the shop where you purchased the product.



This product complies with the European Directives 2006/95/EC, 2004/108/EC and 2011/65/EC.

Hoover Limited Pentrebach, Merthyr Tydfil, Mid Glamorgan CF48 4TU

PRODUCT COMPONENTS

- | | | | |
|----|-----------------------------------|-----|--------------------------|
| A. | Ergonomic Handle | G. | Exhaust Grill |
| B. | On/Off Switch | H. | Main Body |
| | B1. OFF Position | I. | Nozzle Release Button |
| | B2. FLOOR Position | J. | Rear Wheels |
| | B3. CARPET Position | K. | Nozzle |
| C. | Turbo Button | K1. | Removable Agitator Cover |
| D. | Carry Handle | K2. | Front Wheels |
| E. | LED Display* | K3. | Agitator |
| | E1. LED Charging Indicator* | K4. | Flexible Hose |
| F. | Dust Container | L. | Locking Screw |
| | F1. Pre motor filter | M. | Charger |
| | F2. Shroud | | |
| | F3. Dust Bin | | |
| | F4. Dust Container Release Button | | |

PREPARING YOUR CLEANER

1. Line up the ergonomic handle to the main body of the cleaner and fix in position with the supplied locking screw. [2]
2. Line up the nozzle with the main body and firmly push into the neck until it locks into place. [3]
3. Plug charger into the DC socket. For first use, charge your cleaner for 24 hours. [4]
4. The charge indicator will flash when charging.

NOTE: To remove the nozzle press the nozzle release button and pull away from the main body.

NOTE: Use only the charger supplied with your cleaner to recharge.

IMPORTANT: When charging the cleaner the On/Off switch must be in the OFF position.

It is normal for the charger to become warm to the touch when charging.

If the operating times reduces after repeated use let the cleaner run until it stops then recharge for 24 hours, repeat this monthly for best results.

Unplug the charger in the event of prolonged absence (holidays, etc.). Recharge product again before us as batteries may self discharge over increased periods of storage.

USING YOUR CLEANER

Turn the cleaner on by sliding the ON/OFF switch forwards to one of the following settings: [5]

- FLOOR : ideal for hard floor surfaces. Normal power without power brush rotation. [B2]
- CARPET: ideal for carpets and rugs. Normal power with agitator. [B3]
- TURBO: press Turbo button for full power on either floor or carpet mode. [C]

DISPLAY LED*

This cleaner is equipped with a LED display. When the product is on, the display will report the following information:

BATTERY LEVEL INDICATOR*:

- 4 bars = 100% charge
- 3 bars = 75% charge
- 2 bars = 50% charge
- 1 bar = 25% charge

When the batteries are empty the last battery level indicator will flash for 20 seconds before the product switches off automatically.

TURBO: when the Turbo mode is activated on the ergonomic handle, the Turbo icon will light in blue.

CHARGE INDICATOR: When the product is charging, the battery icon will flash every 2 seconds. When fully charged, the icon will stop flashing and remain lit while the charger is plugged in. The icon will switch off when the cleaner is in use.

* Certain Models Only

CLEANER MAINTENANCE

Emptying the Dust Container

1. Press the dust container release button and pull the dustbin forwards to remove it from the main body of the cleaner. **[6]**
2. Hold the unit over a bin and push the bin empty slider to empty the dust container. **[7]**
3. Return the dust container to the cleaner main body. **[8]**.

Cleaning the Filters

1. Press the dust container release button and pull the dust bin forwards to remove it from the main body of the cleaner. **[6]**
2. Pull the filter and shroud assembly from the dust bin using the grips on the filter frame. **[9]**
3. Twist the filter anticlockwise to remove it from the shroud. **[9]**
4. Wash the filter in lukewarm water and leave to dry for 24 hours. Once thoroughly dry reassemble to the shroud and dustbin. **[10]**
5. If required, wash the dustbin in lukewarm water. Ensure it is fully dry before returning to the main body of the cleaner. **[13]**
6. Return the dust container to the cleaner main body. **[8]**.

NOTE: Do not use hot water or detergents when cleaning the filters. In the unlikely event of the filters becoming damaged, fit a genuine Hoover replacement. Do not try and use the product without a filter fitted

IMPORTANT: For optimum performance, always keep your filter clean. We recommend that the filter should be washed once a month.

Changing the Agitator

IMPORTANT: Always switch off the cleaner before changing the agitator.

1. Using a coin, turn the lock to the open position. **[11]**
2. Remove the Agitator cover
3. Remove the old Agitator.
4. Replace with the new Agitator. This can only fit in one direction. **[12]**
5. Replace the Agitator cover and lock with a coin.

Battery Replacement

For reasons of safety the NiMh batteries in this cleaner are only replaceable by a Hoover Service engineer. When the batteries fail to maintain charge, please contact the Hoover Customer Service Centre to arrange a replacement.

End of Product Life Battery Disposal

If the cleaner is to be disposed of the batteries should be removed. Used batteries should be taken to a recycling station and not disposed of with household waste. To remove the batteries, please contact the Hoover Customer Centre or proceed according to the following instructions:

IMPORTANT: Always fully discharge the batteries before removal and ensure the charger is unplugged.

1. Run the cleaner until the batteries are completely empty.
2. Remove the ergonomic handle and the screws, in the main body to open the cleaner.
3. Remove the motor battery housing and disconnect the cables.
4. Remove the batteries from the housing.

NOTE: Should you experience any difficulties in dismantling the unit or for more detailed information about treatment, recovery and recycling of this product, please contact your local city office or your household waste disposal service.

* Certain Models Only

TROUBLE SHOOTING

Should you have any problem with your cleaner, follow this simple check list before calling the Hoover Customer Service Centre:

- A. Cleaner does not switch on.**
Check if the cleaner is charged.

- B. Loss of suction or no suction**
Empty the dust container and wash the filter.
Remove nozzle and check for any blockages in the ducts and hose
Check that the dust container has been correctly fitted.

- C. Fast Flashing indicator (2xper second)**
Incorrect charger connected to product.
Use only charger provided with your cleaner.

- D. Batteries cannot be charged.**
This may be a result of very long storage periods (over half year)
Contact Hoover customer service to arrange battery replacement.

If the problem persists contact the Hoover customer service centre.

HOOVER SPARES AND CONSUMABLES

Always replace parts with genuine Hoover spares. These are available from your local Hoover dealer or direct from Hoover. When ordering parts always quote your model number.

IMPORTANT: The battery in this cleaner is guaranteed for 6 months from purchase. After 6 months the customer is liable for the cost of a new battery which will be fitted free of charge by an authorised Hoover engineer.

Consumables

- Pre motor HEPA Filter: S117 – 35601338

Spares

- Agitator: Y29 – 35601339
- Battery Pack 30V: 48006266 Charger: 48006269
- Battery Pack 26.4V: 48006265 Charger: 48006268
- Battery Pack 20.4V: 48006264 Charger: 48006267
- Battery Pack 18V: 48006138 Charger: 48006258

YOUR GUARANTEE

The guarantee conditions for this appliance are as defined by our representative in the country in which it is sold. Details regarding these conditions can be obtained from the dealer from whom the appliance was purchased. The bill of sale or receipt must be produced when making any claim under the terms of this guarantee.

Subject to change without notice.



®

GENERATION FUTURE

PRINTED IN P.R.C.
48007314/01

HOOVER

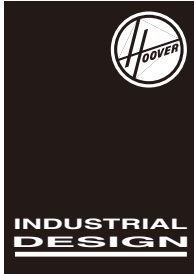

Artwork Number: Issue:
0

Title:
User manual

Created: Date:
Cris

Modified: Date:
Cris 2014/05/12

Engineering Approved: Date:

Hoover Ltd.
Industrial Design Department
5th Floor, 288 Dongping Street,
Suzhou Industrial Park, Suzhou,
PRC 215123
Tel: 0512-82181000 Ext 225

Note:
Artwork not to be used
unless approved by
Engineering.

MANUAL LABEL

Printing colour :

Size : 45x30mm 黑 (black)

Material: Adhesiver sticker (不覆膜不干胶)

Background Colour: White (白色底)

USER MANUAL

Printing colour : 黑 (black)

Size : 210x148mm

Material: 1.cover= 铜版纸 coated paper(120g)

2.inside pages= 双胶纸 offset paper(80g)

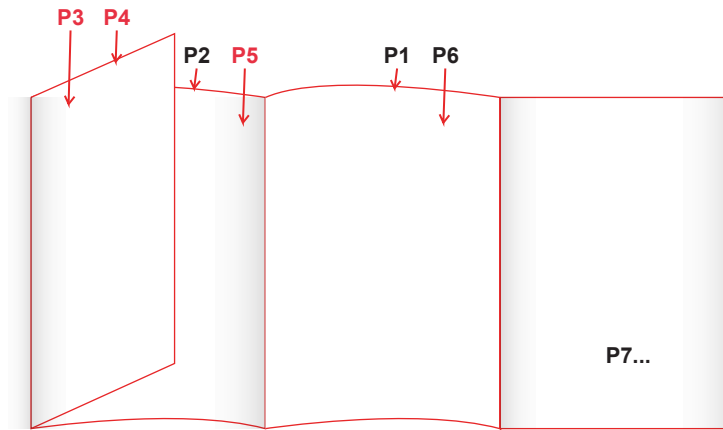
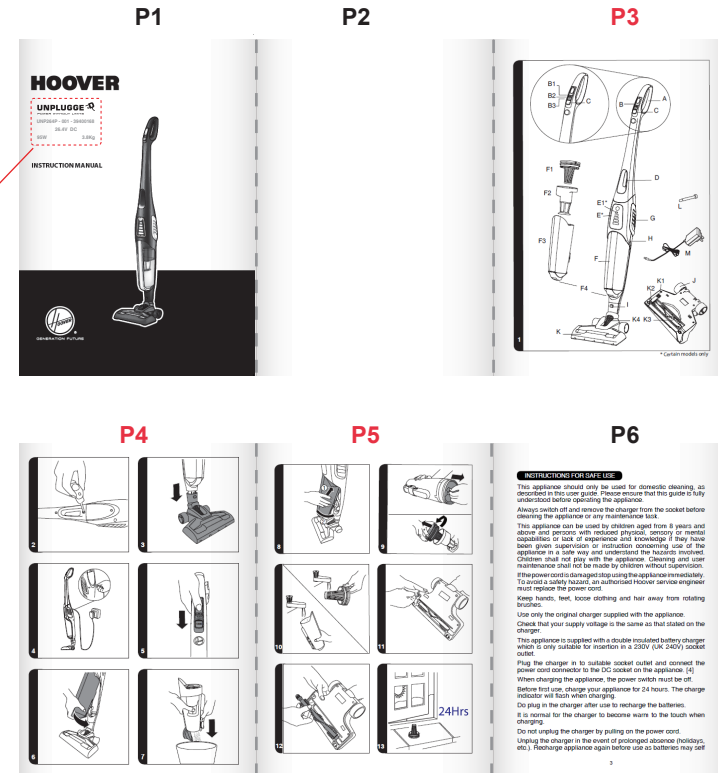

Folding method(折页方法,
如需求插白页一文字的最后面)