

FRIDGE >

User Manual

Model Numbers:

LF60185W

LF60185JW

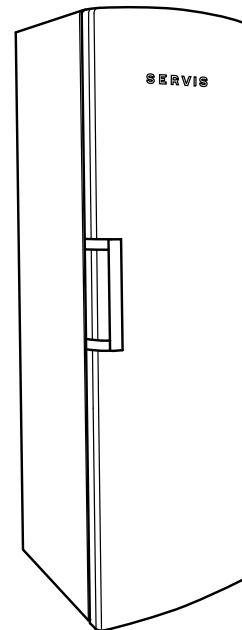

SERVIS
EFFICIENCY BY DESIGN

Visit servis.co.uk



Contents ›

- 01 Welcome
- 02 Safety Instructions
- 07 Your Fridge
- 10 Electrical Information
- 11 Technical Specification
- 12 Installation
- 16 Food Storage Tips
- 18 Cleaning and Care
- 21 Troubleshooting
- 23 Guarantee
- 25 Index

WELCOME >

WELCOME >

Thank you for choosing this Servis Fridge, which has been designed and manufactured to give you many years of trouble-free service.

You may already be familiar with using a similar product but please take time to read these instructions, which have been written to ensure you get the very best from your purchase.

WARRANTY >

Servis provides you with a guarantee which will protect you should your Fridge develop an electrical or mechanical fault during the guarantee period. To ensure that you get a prompt and efficient service, please register your Fridge immediately.

You will find a warranty card included within the packaging. To register, complete the form, or:

- » Visit us at www.servis.co.uk
- » Call us on 0333 577 7232

ITEMS INCLUDED >

Fridge Complete with Shelves and Drawers

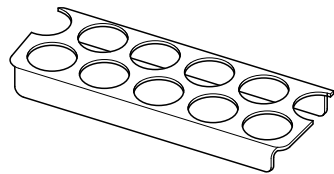
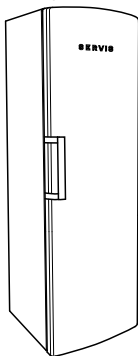

Egg Holder

Figure 1

This illustration is only for information about parts of the appliance. Parts may vary according to the appliance model.

SAFETY INSTRUCTIONS >

To ensure your safety and the safety of others, please read the following safety precautions before you use your Fridge.

- » Your Fridge conforms to current safety requirements. Inappropriate use can, however, lead to personal injury and damage to property. To avoid the risk of accidents and damage to your Fridge, read this user guide carefully before using it for the first time. It contains important information on the installation, safety, use and maintenance of your Fridge. Retain this user guide for future use and pass it on to any new owners. Read this user guide before using or installing your Fridge.
- » Do not expose your Fridge to moisture or rain.
- » Always remove the mains plug from the wall socket when not in use or before any service operation.
- » Your Fridge is for domestic use only and is only intended for the storage of edible foodstuffs.
- » This appliance can be used by children aged from 8 years and above and persons with reduced physical, sensory or mental capabilities or lack of experience and knowledge if they have been given supervision or instruction concerning use of the appliance in a safe way and understand the hazards involved. Children shall not play with the appliance. Cleaning and user maintenance shall not be made by children without supervision.
- » Before setting up your Fridge, check for any external visible damage. Do not install or use your Fridge if it is damaged.
- » Before connecting your Fridge, ensure that the information on the data plate (voltage and connected load) matches that of the mains electricity supply. If in doubt, consult a qualified electrician.

SAFETY INSTRUCTIONS ›

- » Containers with flammable gases or liquids can leak at low temperatures. Do not store any containers with flammable materials, such as spray cans or fire extinguisher refill cartridges in the vicinity of the Fridge.
- » Do not connect your Fridge to the mains electricity supply using an extension lead.
- » A damaged power cord/plug can cause fire or give you an electric shock. When damaged it must be replaced, this should only be done by qualified personnel.
- » Never remove the plug from the socket by pulling the cord. Always hold the plug.
- » Never touch the power cord/plug with wet hands as this could cause a short circuit or electric shock.
- » Never let the power cord be crushed by the Fridge itself or other heavy objects.
- » Never bend the power cord excessively.
- » Never let the power cord touch or pass over heating appliances.
- » Faulty components must only be replaced by a suitably qualified Service Agent using genuine spare parts.
- » Unauthorised repairs could result in unforeseen dangers for the user. Repairs should only be undertaken by an approved service agent.
- » Do not use other electrical appliances inside the Fridge.
- » Do not make any alterations to your Fridge, unless authorised to do so by Servis.
- » The packaging of the machine could be hazardous to children. Please refer to the disposal instructions on the rear cover.
- » Please ensure that you have removed all of the packaging materials and protective tape from your Fridge before using.
- » Please take care when moving your Fridge. It is heavy and we recommend that a minimum of two people move it. Your Fridge has a wheel in each back corner. You will find it easiest to move your Fridge when it is tilted backwards and pushed into position.
- » The small quantity of refrigerant used in the Fridge is eco-friendly R600a (an isobutene) and is flammable/explosive if ignited in enclosed conditions. If the cooler elements have been damaged and you suspect a leak, move the Fridge away from any heat sources or open flame and ventilate the room the Fridge is in for a few minutes.
- » Keep the ventilation openings of the Fridge clear from obstruction.
- » Do not store medicine or academic research samples that require strict temperature control in the Fridge.
- » When cleaning, do not use sharp implements as they may damage the Fridge.

SAFETY INSTRUCTIONS >

Ecological Hints and Tips:

We have provided a few important hints and tips, so that you can save on the cost of energy and help protect the environment.

- » Do not install the Fridge close to sources of heat such as a radiator or a cooker.
- » Install the Fridge in a well ventilated room and keep the openings clear from obstruction.
- » Do not install the Fridge on a wet floor or in a location with high humidity/moisture content.
- » Food which is to be frozen (when cool) should be placed in the main part of the fridge before being transferred to a freezer.
- » Do not place food against the turbo fan, otherwise air circulation within the fridge will be impaired.
- » Ensure there are no obstructions preventing the door from closing properly.
- » Try to avoid keeping the door open for long periods or opening the door too frequently as warm air will enter the cabinet and cause the compressor to switch on unnecessarily often.
- » Clean the condenser on the back of the Fridge at least once a year to make sure it is free from dust and dirt.

Environmental Information:

- » Once installation is complete, please dispose of the packaging with due regard to safety and the environment. Disposal instructions can be found on the rear cover.
- » Your Fridge does not contain gases which damage the ozone layer, in either its refrigerant circuit or insulation materials.

YOUR FRIDGE >

FRONT VIEW >

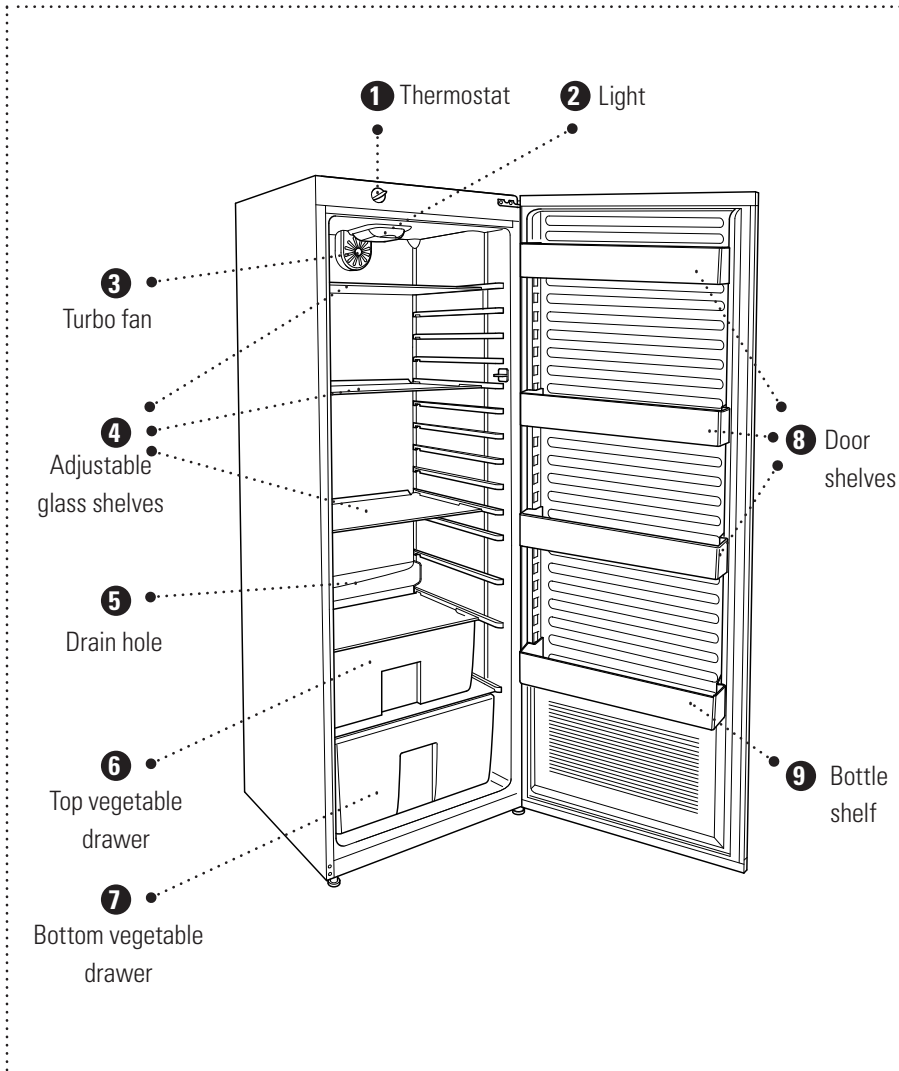
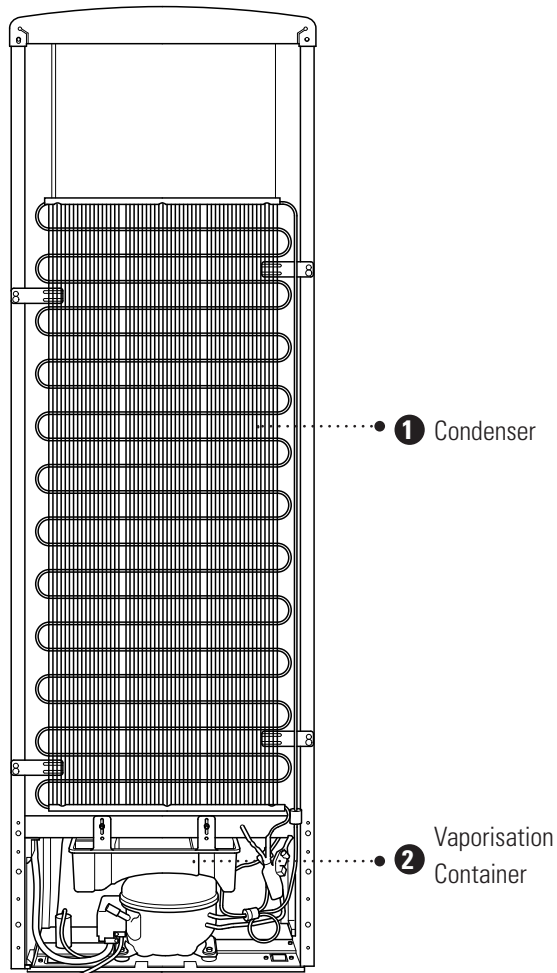

Figure 2

The following information will help you to identify the different parts of your Fridge and provide suggestions on the best way to use them.

- 1 Thermostat - see page 14.
- 2 Light - see page 20.
- 3 Turbo fan
- 4 Adjustable glass shelves
- 5 Drain hole
- 6 Top vegetable drawer
- 7 Bottom vegetable drawer
- 8 Door shelves
- 9 Bottle shelf

REAR VIEW >



- ❶ Condenser.
- ❷ Vaporisation Container.

ELECTRICAL INFORMATION >

- » Your Fridge requires a 220-240V, 50Hz mains supply. Do not use any other supply.
- » If your plug requires changing because it is not suitable for your socket, or it is damaged, you should consult a qualified electrician.

Fuse:

- » Replacement fuses should be ASTA-approved to BS1362 and have the correct 13 Amp rating.
- » Replacement fuses can be purchased from an electrical supplier.

Figure 3

TECHNICAL SPECIFICATION >

Model Number	LF60185W / LF60185JW
Power Source	220-240 V AC, 50Hz
Energy Consumption	0.373 kWh/24h
Climate Class	N (16°C - 32°C)
Refrigerant Gas	R600a
Gas Capacity	47 gr
Input Power	144 W
Fridge Light	LED Light
Energy Efficiency Rating	A+ Class
Minimum Room Temperature	16°C

INSTALLATION REQUIREMENTS >

Before unpacking and manoeuvring your Fridge, please take the time to read and become familiar with the following points:

- » To avoid risk of injury, please take care when moving your Fridge. It is heavy and we recommend that a minimum of two people move it. Your Fridge has a wheel in each back corner. You will find it easiest to move your Fridge when it is tilted backwards and pushed into position.
- » Make sure that your Fridge can fit through all doorways on route to its final location. The dimensions of your Fridge (including the handle) are 1700 mm high x 610 mm wide x 655 mm deep.

Your Fridge should be positioned in a location that meets the following requirements:

- » In a dry room that can be ventilated and out of direct sunlight.
- » Away from any heat source such as a radiator. If this is unavoidable, a suitable heat insulator should be used (this is not supplied).
- » On a suitable floor that will not become damaged, or sag under the weight of the Fridge.
- » At least 500 mm away from stoves, ovens and heater cores and 50 mm away from electrical ovens.
- » At least 20 mm away from a freezer.
- » Clearance of at least 200 mm is required at the top and back of your Fridge. Do not place anything on top of your Fridge.

INSTALLATION >

ADJUSTING THE FEET >

For safe operation, it is important that your Fridge is stable and balanced. The two adjustable feet at the front are used to level your Fridge. Make sure that your Fridge is level before placing any foodstuffs inside it.

- 1 To increase the height of the Fridge, turn the feet clockwise (Figure 4).
- 2 To decrease the height of the Fridge, turn the feet anti-clockwise (Figure 4).

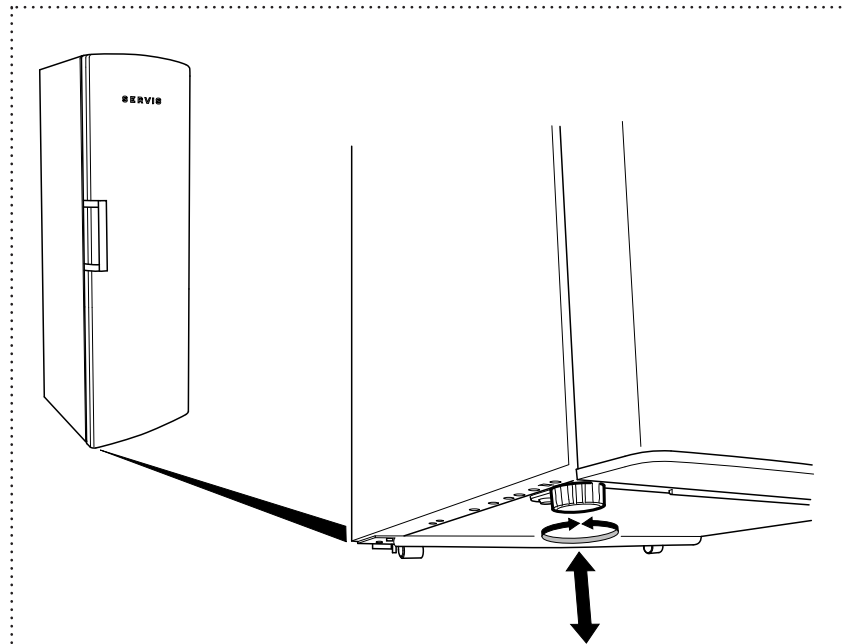

Figure 4

TEMPERATURE CONTROL >

The thermostat (Figure 5) is used to regulate the temperature in the fridge. It can be set to any value from 1-5, where 5 is the setting with the lowest temperature. For normal everyday use we recommend a value of 3-5.

- 1 To select a higher number (lower the temperature), turn the thermostat dial clockwise.
- 2 To select a lower number (raise the temperature), turn the thermostat dial anti-clockwise.

- » We do not recommend that you operate your Fridge in environments colder than 10°C as efficiency is reduced.
- » Your Fridge is designed to operate in an ambient temperature of 16°C to 43°C.

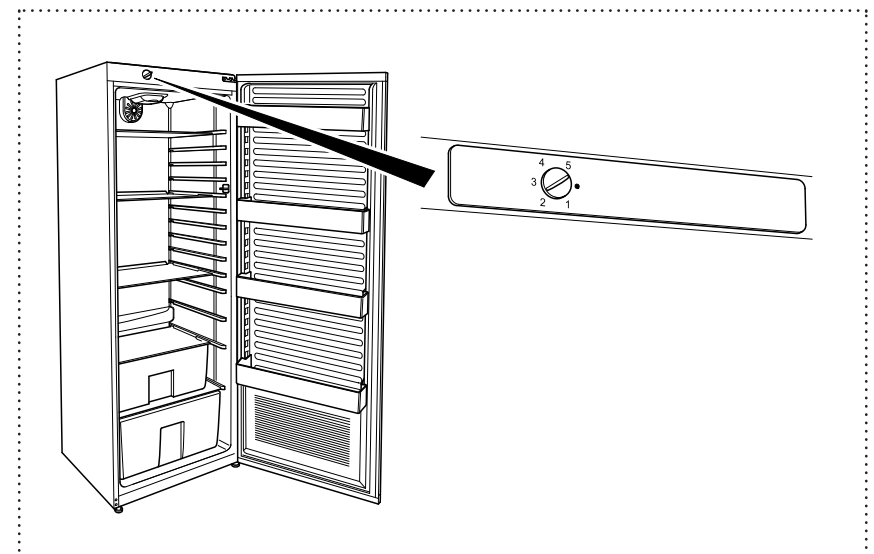

Figure 5

BEFORE USING YOUR FRIDGE >

- » When using your Fridge for the first time, or after transportation, keep it in an upright position for at least 3 hours before plugging into the mains. This allows efficient operation and prevents damage to the compressor.
- » We recommend that you wipe all shelving and trays with a cloth soaked in warm water mixed with a teaspoon of sodium bicarbonate before use. After cleaning, rinse with warm water and dry.
- » You may notice a slight odour when using your Fridge for the first time. This is perfectly normal and will fade away once the fridge starts to cool.
- » Before using your Fridge, make sure that it has been connected to an appropriate mains power supply and is switched on at the socket.
- » When using your Fridge for the first time, set the thermostat to a value of 4 for the first 24 hours. Avoid opening the door while the Fridge is cooling down and do not place a lot of food inside the Fridge, otherwise it will take longer to reach operating temperature.
- » Your Fridge has a 5 minute built in delay function, designed to prevent damage to the compressor. When power is applied to your Fridge, it will begin to operate normally after 5 minutes.

FOOD STORAGE GUIDANCE >

To help you use your Fridge efficiently, please take the time to read the following tips and guidance.

Storage Areas:

The circulation of air within your Fridge causes areas of different temperatures. It is recommended that you make use of these areas when storing your food.

The coldest area of the fridge compartment is at the bottom, above the vegetable drawer. We recommend that you use this area to store food that will perish easily, such as fish, ready meals, baked goods and dairy products.

The warmest area of your fridge is the top shelf of the door. We recommend that you store butter and cheeses in this shelf.

Storing food:

It is best to store your food covered or packaged, to prevent it from drying out, and to prevent smells affecting other food in your Fridge. Store fruit and vegetables loose in the vegetable containers. Avoid storing potatoes, onions and garlic in your refrigerator.

Other tips you might find helpful are:

- » Wash your food before storage.
- » Allow warm or hot food to cool down before storing. This helps to reduce power consumption.

FOOD STORAGE TIPS >

- » Keep as much space as possible between your items of food. This allows the cold air to circulate freely around them.
- » Take care when storing tropical fruit such as pineapples as they can quickly deteriorate in lower temperatures.
- » Divide and separate food into smaller pieces before storage.
- » Cover or wrap food to prevent odours. We recommend that you store meat loosely covered as this allows air to circulate around the meat causing the surface to dry slightly, helping to prevent the growth of bacteria.
- » Do not store food close to the lamp, or block the cover or the cooling compartment.

The table below is a quick guide, showing you the most efficient way to store the major food groups in your refrigerator.

Food	Storage Duration	Location
Fruits and Vegetables	1 week	Loose in Vegetable Drawer
Fish and Meat	2-3 Days	Wrapped on Glass Shelf
Fresh Cheese	3-4 Days	Top Door Shelf
Butter and Margarine	1 Week	Top Door Shelf
Bottles, Yogurt and Milk	Refer to Packaging	Door Shelf
Eggs	1 month	Door Shelf

CLEANING AND CARE >

Power Disruption:

In the event of a power cut, please do not open the door of the freezer compartment. Your Fridge will preserve your frozen food in an ambient environmental temperature of 25°C for approximately 13 hours. This time period will be shorter if the ambient temperature is higher. When power is re-applied after a power cut your Fridge will not operate for 4-5 minutes. This is to allow the gas in the cooling system to balance and is perfectly normal.

CLEANING AND CARE >

From time to time it will be necessary to carry out cleaning of your Fridge.

- » Before cleaning your Fridge, turn your mains power supply off and remove the plug from the socket.
- » Do not wash your Fridge by pouring water on it.
- » Use a warm, soapy cloth or sponge to wipe the interior and exterior of your Fridge.
- » Carefully remove all shelves and drawers by sliding outwards or upwards and clean with soapy water. Do not wash in a washing machine or dish washer.
- » Clean the condenser at the back of your Fridge at least once a year with a soft brush or vacuum cleaner.
- » Do not use solvents, abrasive cleaners, glass cleaners or all purpose cleaning agents to clean your Fridge. They may damage the plastic surfaces and other components with the chemicals they contain.

CLEANING AND CARE >

Cleaning The Vaporisation Container:

Your Fridge performs fully automatic defrosting. The water formed as a result of this automatic defrosting flows into the vaporisation container at the rear of your Fridge and evaporates. We recommend cleaning the vaporisation container at regular intervals to prevent odours from building up.

To clean the vaporisation container:

- 1 Remove the vaporisation container by unscrewing the 2 screws (a) and (b) (Figure 7)
- 2 Clean the vaporisation container with warm soapy water and dry with a cloth.
- 3 Re-fit the vaporisation container by screwing it back into position.

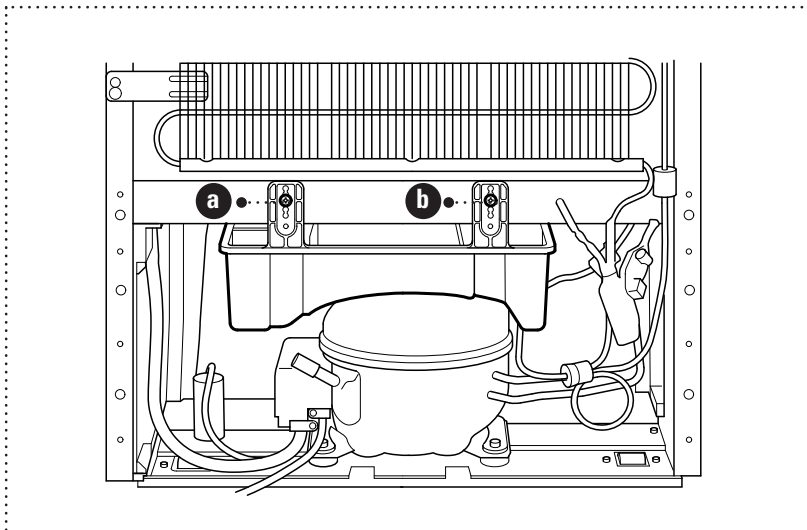

Figure 7

Replacing the LED:

Contact the Servis helpdesk.

Replacing the Lamp Bulb:

To replace the bulb:

- 1 Check that your Fridge is turned off and unplugged from the mains.
- 2 Remove the light cover using a screwdriver to release the claws (Figure 8 a).
- 3 Unscrew the bulb by turning it clockwise, and remove (Figure 8 b).
- 4 Replace with a 15 Watt bulb.
- 5 Re-fit the light cover, by pushing it upwards until it clicks back into position (Figure 8 c).

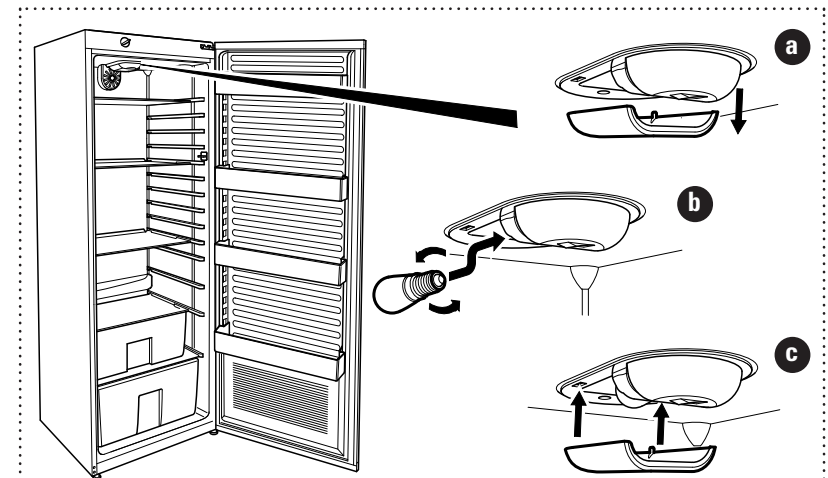

Figure 8

TROUBLESHOOTING >

TROUBLESHOOTING INFORMATION >

If your Fridge is not operating as expected, you may find a simple solution listed in the table below.

If your Fridge has developed a fault not covered in this manual, please contact the Servis helpdesk.

Fault	Possible Cause	Solution
Your Fridge does not operate.	It is switched off at the mains.	Check that your Fridge is plugged in and turned on at the mains.
Your Fridge does not get cold enough.	The thermostat is set too low.	Turn the thermostat to a higher value. (A setting of 5 will provide the lowest temperature).
	The door is opened and closed too frequently.	Try to reduce the number of times the door is opened and closed.
	The door seal is faulty.	Contact Servis.
	The refrigerator is overfilled.	Check that there is enough space between items to allow air circulation. Make sure that no items of food are blocking the air vents.

Fault	Possible Cause	Solution
Your Fridge is noisy.	Your Fridge may not be level.	Adjust the feet to level your Fridge. See page 13.
	Please note that certain noises may heard from your Fridge during use. They are perfectly normal from a frost free Fridge and are not damaging your Fridge. Contact the Servis helpdesk if you have any concerns.	
There is moisture on the inner parts of your Fridge.	The door is opened and closed too frequently.	Try to reduce the number of times the door is opened and closed.
There is loose water in the bottom of the fridge.	The drain hole at the back of the fridge may be blocked.	Use the drain plug to clear the drain hole.
The door does not close properly.	Items of food may prevent the door from closing.	Make sure that the door is free from obstruction.
	The shelves and drawers are not correctly in position.	Check that the shelves and drawers are properly placed in position.
	The door seal is damaged.	Contact the Servis helpdesk.
	Your Fridge is not level.	Adjust the feet to level your Fridge. See page 13.

GUARANTEE >

DISPOSAL OF YOUR OLD FRIDGE >

All packaging and materials used are environmentally friendly and recyclable. Please dispose of any packaging in an environmentally friendly manner. Consult your local council for further details.

- » When the Fridge is to be scrapped, cut off the electrical supply cable and destroy the plug with the remaining cable. Disable the door catch in order to prevent children from becoming trapped inside while playing. A cut off plug inserted into a 13 amp socket is a serious safety (shock) hazard. Please ensure the cut off plug is disposed of safely.



Please refer to the rear cover for disposal instructions.

GUARANTEE >

The Servis guarantee covers the cost of parts/labour/call out charges to repair an appliance should any covered component fail in its normal functions necessitating a repair or replacement to resume those functions.

The Servis guarantee **does not** cover:

- » Accidental damage
- » Use in a commercial environment
- » Incorrect or faulty installation
- » Deliberate damage or neglect
- » Repairs to cosmetic parts

- » Damage caused by foreign objects or substances
- » Claims in respect to routine inspection or maintenance

The Servis guarantee is not transferable.

For your Servis guarantee to be valid, you will need to retain your original purchase receipt and be able to provide it when you make a claim.

The above summary does not include all of the terms and conditions and exclusions which can be found on our website www.servis.co.uk.

KNOW YOUR RIGHTS >

Household contents insurance

Your household insurance may cover you for accidental damage, fire or theft of your product.

Data Protection Act (1988)

Please note that any information provided will be processed by us or our agents in compliance with the provisions of the Data Protection Act 1988, for the purpose of providing cover and handling claims, if any, which may necessitate providing such information to third parties.

INDEX >

A

Adjusting the feet13

B

Before using your fridge15

C

Cleaning and care18

D

Disposal23

E

Ecological hints and tips05

Electrical information.....10

Environmental information.....06

F

Food storage guidance16

Fuse.....10

G

Guarantee.....23

I

Installation requirements.....12

Items included01

P

Power disruption18

R

Replacing the lamp bulb20

S

Safety instructions.....02

T

Technical specification11

Temperature control14

Troubleshooting information21

W

Warranty.....01

T: 0333 577 7232
E: info@servis.co.uk

 Visit
servis.co.uk

SERVIS
EFFICIENCY BY DESIGN



The symbol on the product or on its packaging indicates that this product may not be treated as household waste. Instead it shall be handed over to the applicable collection point for the recycling of electrical and electronic equipment. By ensuring this product is disposed of correctly, you will help prevent potential negative consequences for the environment and human health, which could otherwise be caused by inappropriate waste handling of this product. For more detailed information about recycling of this product, please contact your local city office, your household waste disposal service or the shop where you purchased the product.

000000000