

New Hallingford - Dresser and Stool

Assembly Instructions - Please keep for future reference

258/7796

274/9424

259/8321

247/8740

274/5136

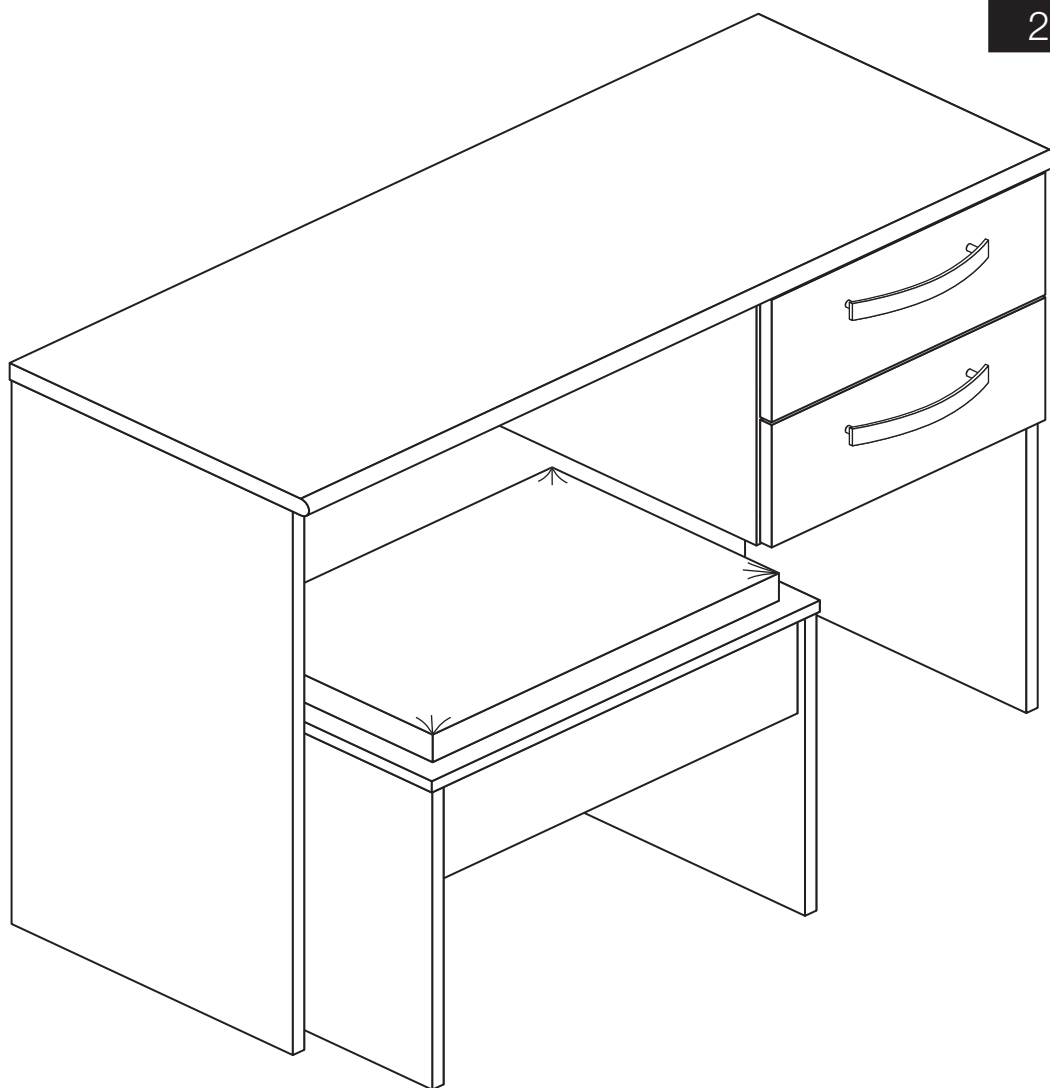

Dresser Dimensions

Width - 99cm

Depth - 40cm

Height - 74.5cm

Stool Dimensions

Width - 51.5cm

Depth - 35.5cm

Height - 45cm



**MADE IN
BRITAIN**

Important - Please read these instructions fully before starting assembly

If you need help or have damaged or missing parts, call the **Customer Helpline: 0870 112 1928** or email: Help@ClickSpares.co.uk (quoting your original order number)



Safety and Care Advice

Important - Please read these instructions fully before starting assembly

- **Warning:** This unit weighs approximately 29.5kgs. Please lift with care.
- Check you have all the components and tools listed on pages 1, 2 and 3.
- Remove all fittings from the plastic bags and separate them into their groups.
- Keep children and animals away from the work area, small parts could choke if swallowed.
- Parts of the assembly will be easier with 2 people.

- Make sure you have enough space to layout the parts before starting.
- Do not stand or put weight on the product, this could cause damage.
- Assemble the item as close to its final position (in the same room) as possible.
- Assemble on a soft level surface to avoid damaging the unit or your floor (use opened out unit carton).



• We do not recommend the use of power drill/drivers **for inserting screws**, as this could damage the unit. Only use hand screwdrivers.

- **Safety note:** If there is any chance of this unit being pulled over by children etc. it is recommended that the unit is secured to a wall using suitable fixings (not supplied).
- Dispose of all packaging carefully and responsibly.

Care and maintenance

- Only clean using a damp cloth and mild detergent, do not use bleach or abrasive cleaners.
- From time to time check that there are no loose screws on this unit.
- This product should not be discarded with household waste. Take to your local authority waste disposal centre.

Tools required



Rule



Cross-head screwdriver



Scissors



Hammer



Eye protection
(when using a hammer or drill)

Note: If required the next page can be cut out and used as reference throughout the assembly. Keep this page with these instructions for future reference.

Components - Panels

If you have damaged or missing components, call the **Customer Helpline: 0870 112 1928** or email: **Help@ClickSpares.co.uk** (quoting your original order number and the reference numbers below)

Please check you have all the panels listed below

Dresser

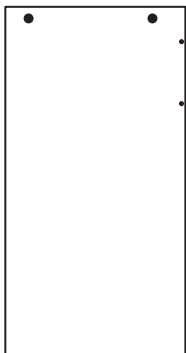

1 Left Side (D2327A)
(721 x 372mm)

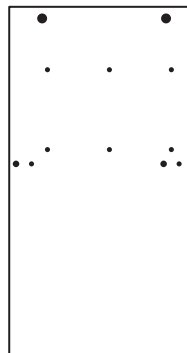

2 Right Side (D2328A)
(721 x 372mm)

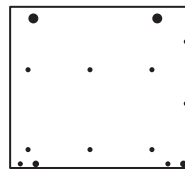

3 Upright (D2329A)
(333 x 372mm)



4 Modesty (D2330A)
(598 x 244mm)



5 Rail (D2331A)
(342 x 66mm) x 2

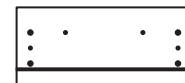

6 Drawer Front (D2309A)
(362 x 162mm) x 2

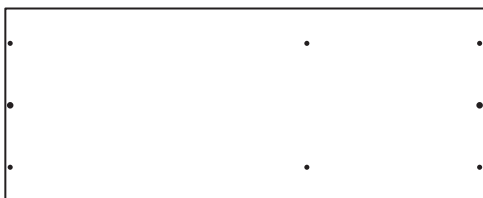

7 Top (D2326A)
(990 x 396mm)

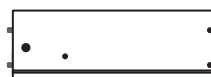

8 Left Drawer Side (W370-124LH)
(370 x 124mm) x 2



9 Right Drawer Side (W370-124RH)
(370 x 124mm) x 2



10 Drawer Back (W291-124)
(291 x 124mm) x 2

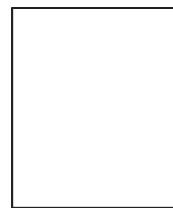

11 Drawer Base (T304-367)
(304 x 367mm) x 2

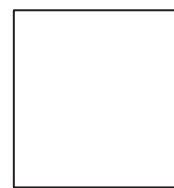

12 Back (X350-366)
(350 x 366mm)

Stool

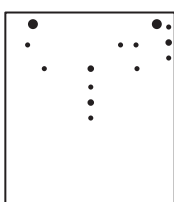

13 Stool Left Side (D2333A)
(395 x 350mm)

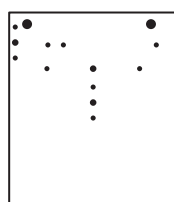

14 Stool Right Side (D2334A)
(395 x 350mm)

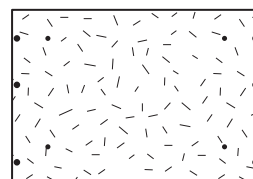

15 Stool Top (D2332A)
(513 x 353mm)

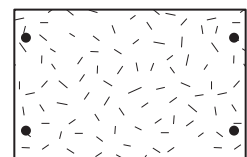

16 Stool Base (D2336A)
(478 x 308mm)

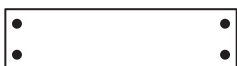

17 Stool Rail (D2335A)
(478 x 124mm) x 2

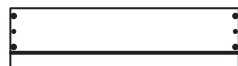

18 Stool Drawer Front (D2338A)
(472 x 126mm)

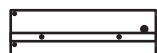

19 Stool Left Drawer Side (W410LH)
(300 x 95mm)

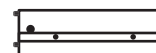

20 Stool Right Drawer Side (W410RH)
(300 x 95mm)

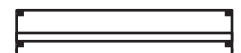

21 Stool Drawer Back (W445-95)
(445 x 95mm)



22 Stool Seat Pad (FHALPAD)
(458 x 300mm)



23 Stool Drawer Base (T456-297)
(456 x 297mm)











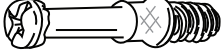



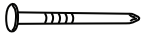



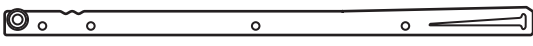

Components - Fittings

If you have damaged or missing components, call the **Customer Helpline: 0870 112 1928** or **email: Help@ClickSpares.co.uk** (quoting your original order number and the reference numbers below)

Please check you have all the fittings listed below

Note: The quantities below are the correct amount to complete the assembly. In some cases more fittings may be supplied than are required.

<p>A </p> <p>Wooden dowel (F22) x 14</p>	<p>B </p> <p>Metal dowel (F901) x 36</p>	<p>C </p> <p>Small locking nut (F3) x 6</p>
<p>D </p> <p>Large locking nut (F900) x 30</p>	<p>E </p> <p>Knock-in Peg (F171GY) x 12</p>	<p>F </p> <p>Nail (F51) x 10</p>
<p>G </p> <p>19mm Screw (F461) x 4</p>	<p>H </p> <p>13mm Screw (F52) x 12</p>	<p>I </p> <p>13mm Screw (F63) x 12</p>
<p>J </p> <p>9mm Screw (F74) x 2</p>	<p>K </p> <p>9mm Screw (F73) x 4</p>	<p>L </p> <p>25mm Screw (F50) x 4</p>
<p>M a  L Runner (F159) x 2 ← 350mm long →</p> <p>M b  R Runner (F160) x 2</p> <p>M c  L Runner (F161) x 2</p> <p>M d  R Runner (F162) x 2</p>		<p>N  Drawer runner (F1004) x 2 ← 280mm long →</p> <p>O  Handle (F278) x 2</p>
<p>P </p> <p>Wedgex (F639) x 6</p>	<p>Q </p> <p>Plastic Nail (F91) x 8</p>	

Ruler - Use this ruler to help correctly identify the screws

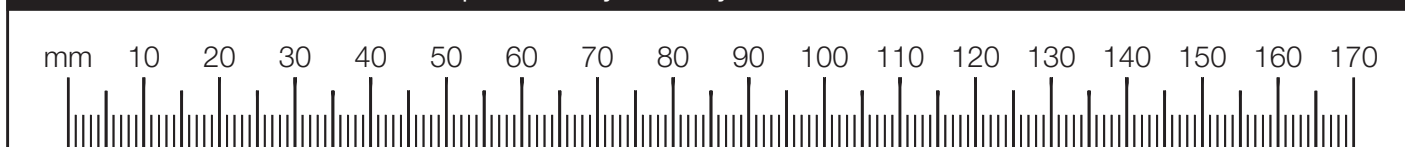

Assembly Instructions

If you have damaged or missing components, call the Customer Helpline: 0870 112 1928 or email: Help@ClickSpares.co.uk (quoting your original order number and the reference numbers below)

Step 1

Prepare the 2 drawer fronts

Screw 2 metal dowels **B** into the holes shown on the back of each drawer front **6**.

Note: Tighten metal dowels up fully against the panels.

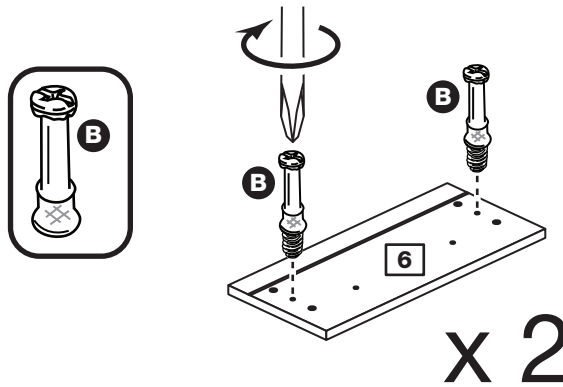

Step 2

Prepare the drawer sides

Insert a small locking nut **C** into the hole shown on the left drawer side **8** and right drawer side **9**.

Note: Arrow on locking nut **must** point towards hole in edge of panel.

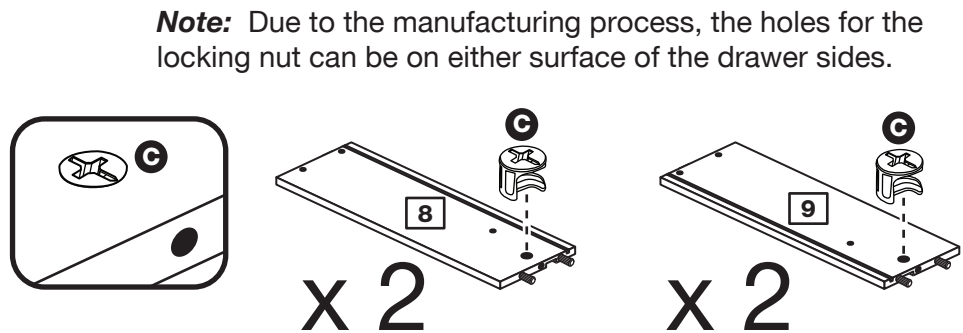

Step 3

Attach the drawer sides to the drawer front

Push the left drawer side **8** and right drawer side **9** onto the back of the drawer front **6**.

Turn the small locking nuts **C** on the left drawer side **8** and right drawer side **9**.

Note: Turn the locking nuts **C** clockwise to secure panels - more than 1/2 a turn.

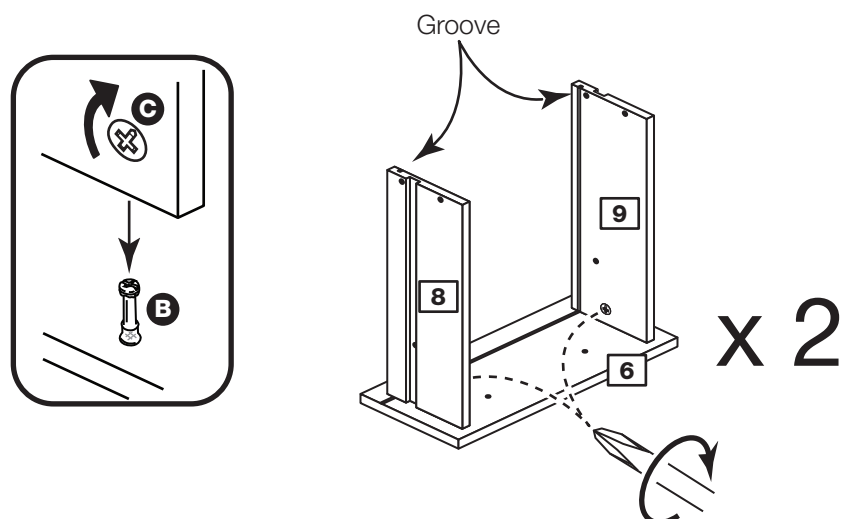

Assembly Instructions

Step 4

Fit the drawer base

Slide the drawer base **11** down the grooves in the drawer sides **8** and **9** and down into the groove in the drawer front **6**.

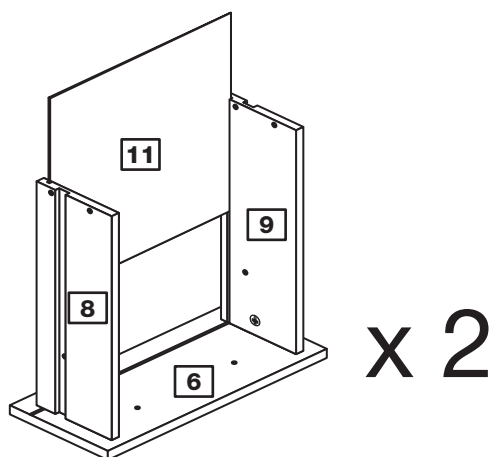

Step 5

Fit the drawer back

Fit the drawer back **10** between the drawer sides **8** and **9**.

Make sure that the drawer base **11** fits into the groove in the drawer back **10**.

Hold the drawer back **10** in position and tap the knock-in pegs **E** through the holes in the drawer sides **8** and **9**.

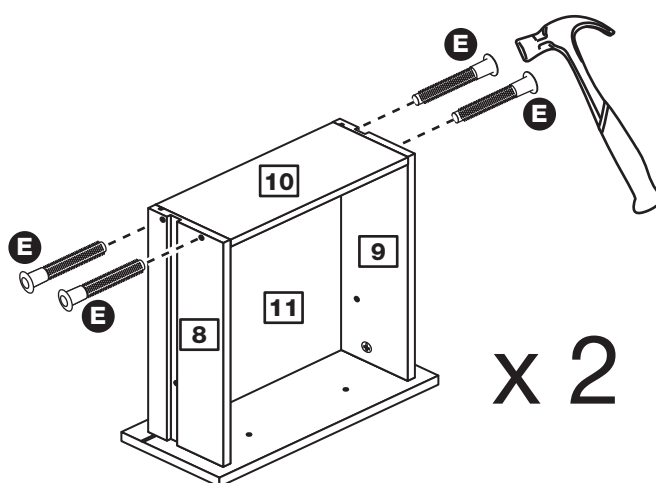

Step 6

Attach the handle

Attach a handle **O** to each drawer front **6** using 2 screws **G**.

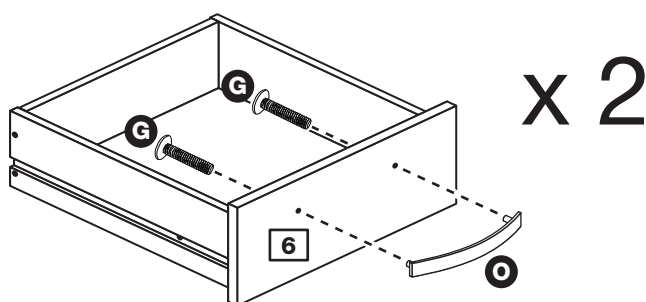

Step 7

Fit the wedgexes

Turn the drawer assemblies over and slide 2 wedgexes **P** into the front and back grooves, as shown, and tighten up the screws.

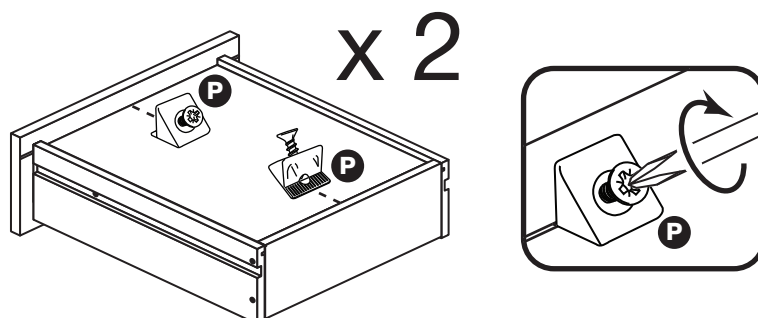

Assembly Instructions

Step 8

Fit runners to the drawers

Fit runner **Md**, marked with 'R', to the bottom edge of the right drawer side **9**, as shown, making sure that it is pushed up against the back of the drawer front **6**.

Use a bradawl to mark the fixing positions, then secure with 2 screws **I**.

Fit runner **Mc**, marked 'L', to the bottom edge of the left drawer side **8** using the same method.

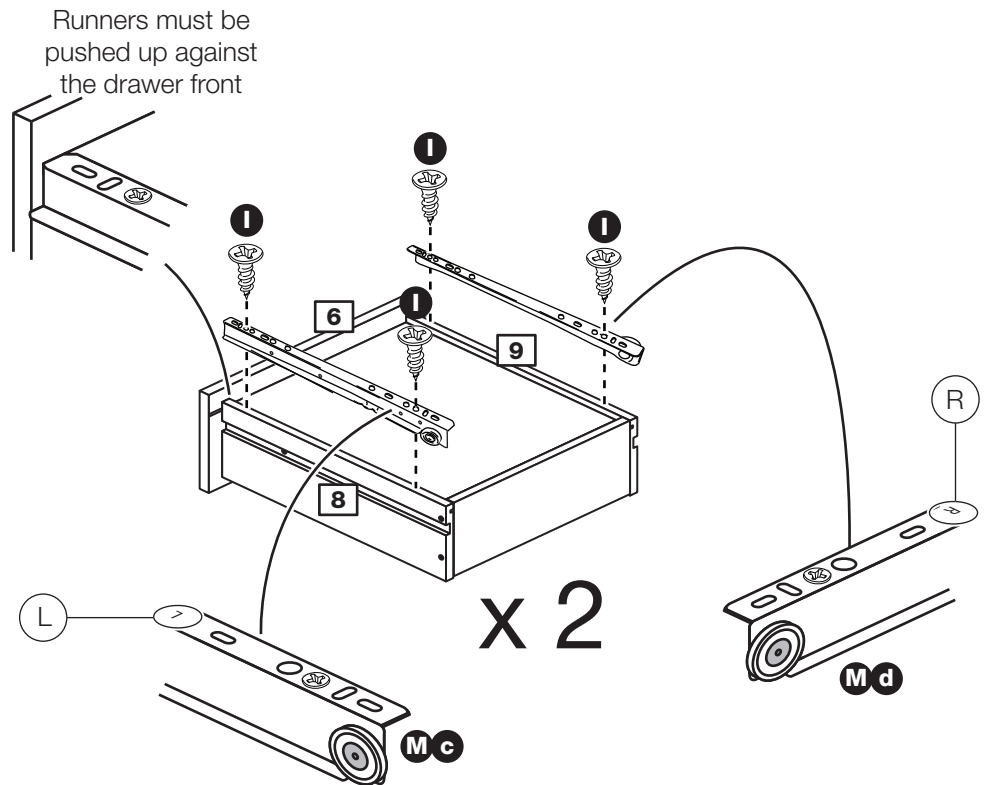

Step 9

Prepare the 2 rails

Tap 2 wooden dowels **A** into each rail **5**.

Note: Wooden dowels **must not** stick out from the edge by more than 10mm or they may damage other panels.

Insert 2 large locking nuts **D** into each rail **5**.

Note: The arrow on the locking nut **must** point towards the hole in the edge of the panel.

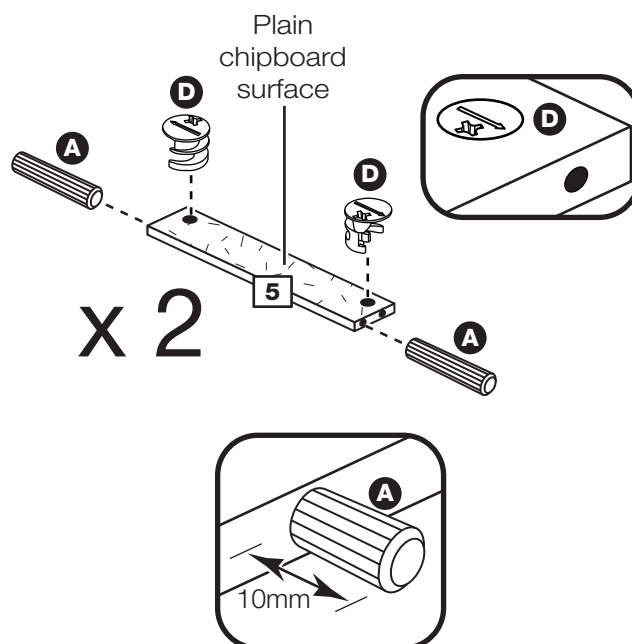

Assembly Instructions

Step 10

Prepare the right side

a: Fit 2 runners **Mb** to the right side **2**.

The 1st screw **H** uses the 2nd hole in from the front of the runner.

The 2nd and 3rd screws **H** use the holes that line up with the other panel holes.

b: Fit a screw **I** into the 2nd hole in at the top of the runner **Mb**.

Screw 2 metal dowels **B** into the right side **2**.

Insert 2 large locking nuts **D** into the right side **2**.

Tap a wooden dowel **A** into the right side **2**.

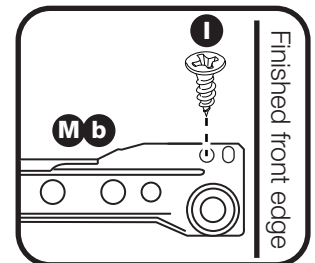
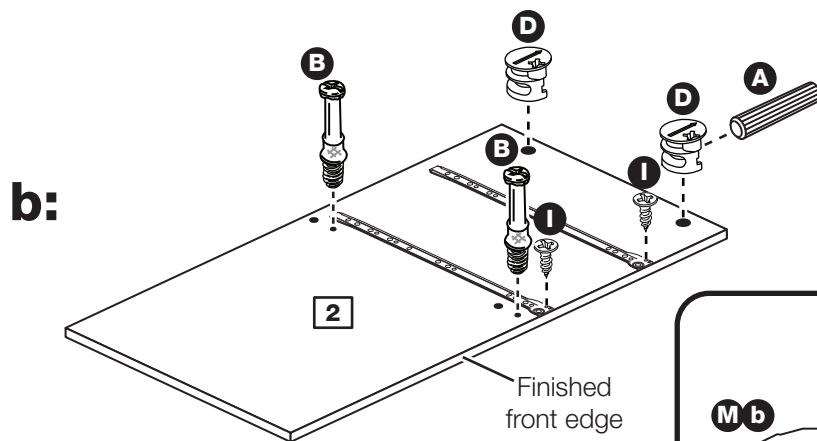
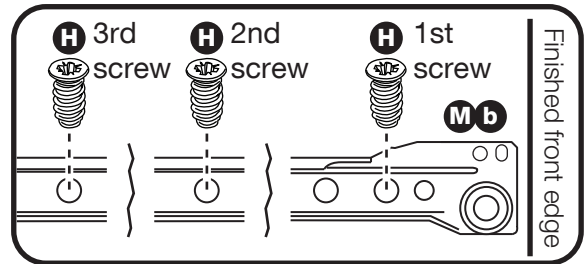
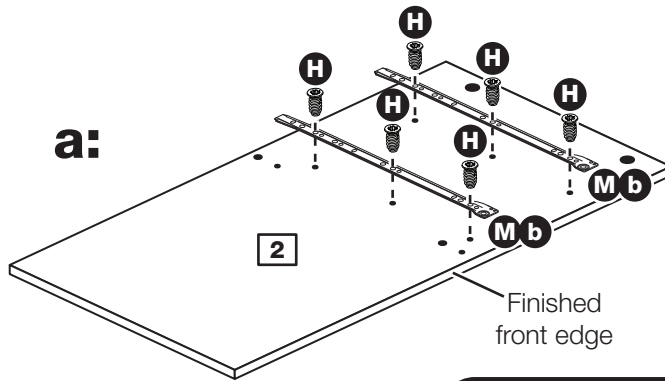

Step 11

Join the rails to the right side

Push the 2 rails **5** onto the right side **2**.

Use a screwdriver to tighten the 2 large locking nuts **D** fitted to the rails **5**.

Note: Turn the large locking nuts **D** as far as they will go - more than 1/2 a turn.

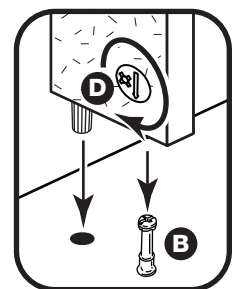
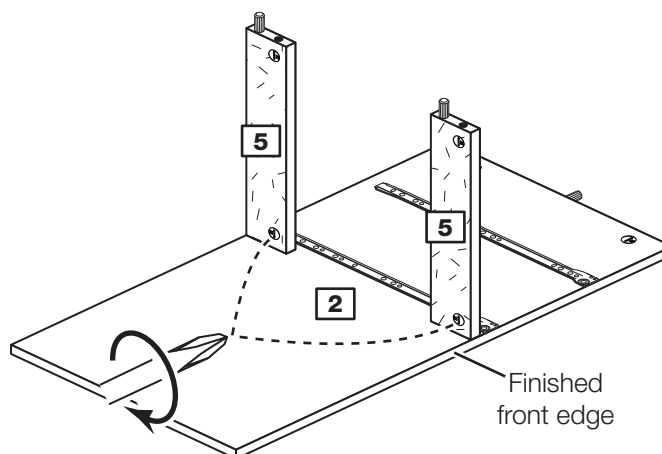

Assembly Instructions

Step 12

Prepare the upright

a: Fit 2 runners **Ma** to the upright **3**

The 1st screw **H** uses the 2nd hole in from the front of the runner.

The 2nd and 3rd screws **H** use the holes that line up with the other panel holes.

b: Fit a screw **I** into the 2nd hole in at the top of the runners **Ma**.

Screw 2 metal dowels **B** into the upright **3**

Insert 2 large locking nuts **D** into the upright **3**.

Turn the upright over

c: Screw 2 metal dowels **B** into the upright **3**.

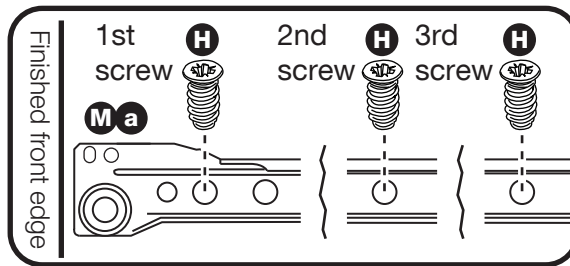

a:

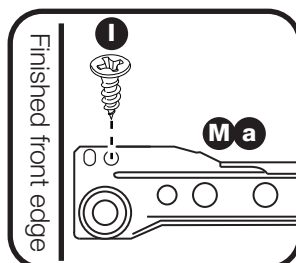
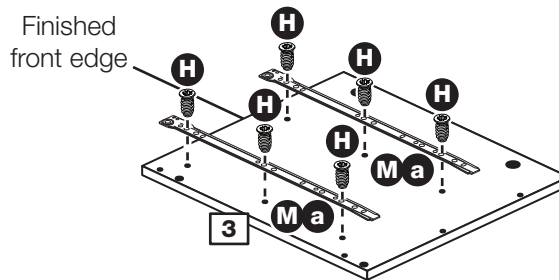

b:

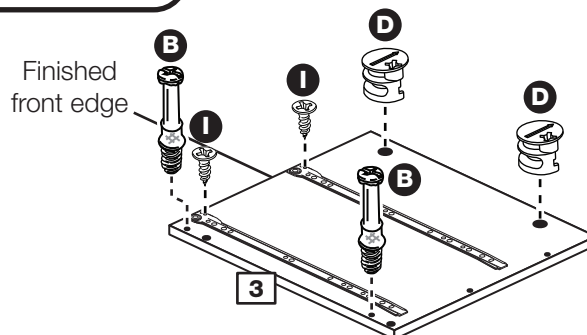

Turn the upright over



c:

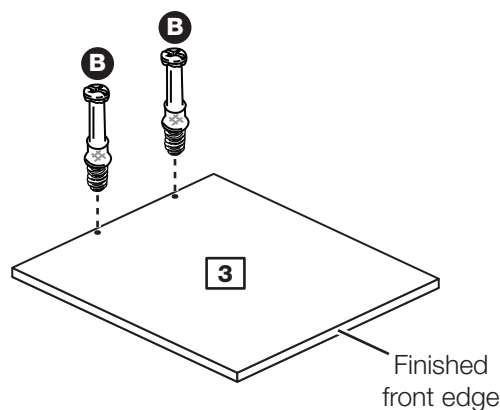

Assembly Instructions

Step 13

Fit the upright

Push the upright **3** onto the 2 rails **5**.

Use a screwdriver to tighten the 2 large locking nuts **D** fitted to the rails **5**.

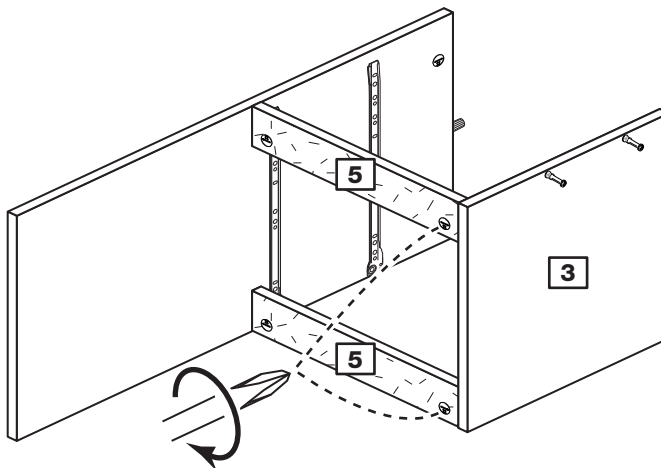

Step 14

Prepare the modesty

Insert 4 large locking nuts **D** into the modesty **4**.

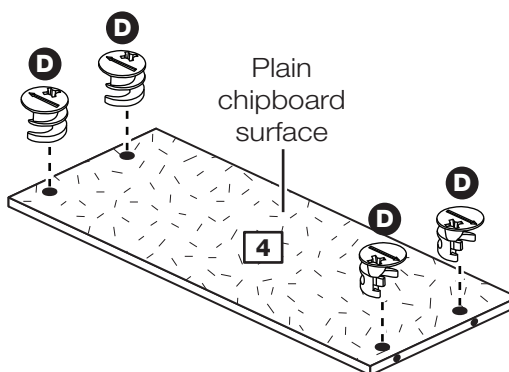

Step 15

Prepare the left side

Tap a wooden dowel **A** into the left side **1**.

Screw 2 metal dowels **B** into the left side **1**.

Insert 2 large locking nuts **D** into the left side **1**.

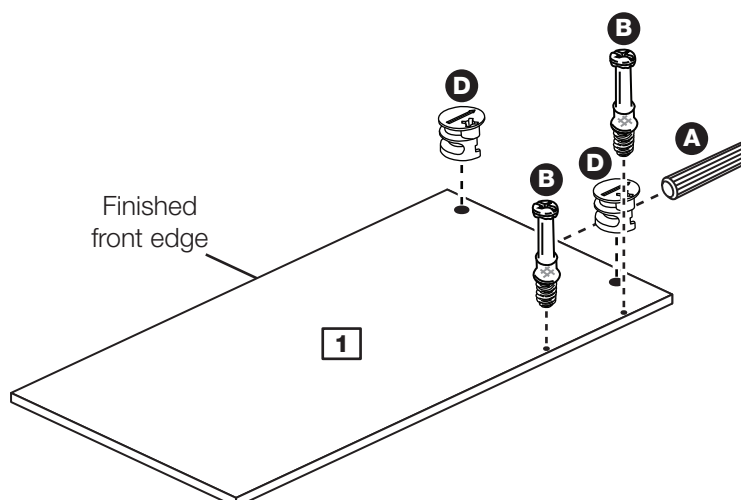

Assembly Instructions

Step 16

Join the modesty to the left side

Push the modesty **4** onto the left side **1**.

Note: The top edges should be flush.

Use a screwdriver to tighten the 2 large locking nuts **D** fitted to the modesty **4**.

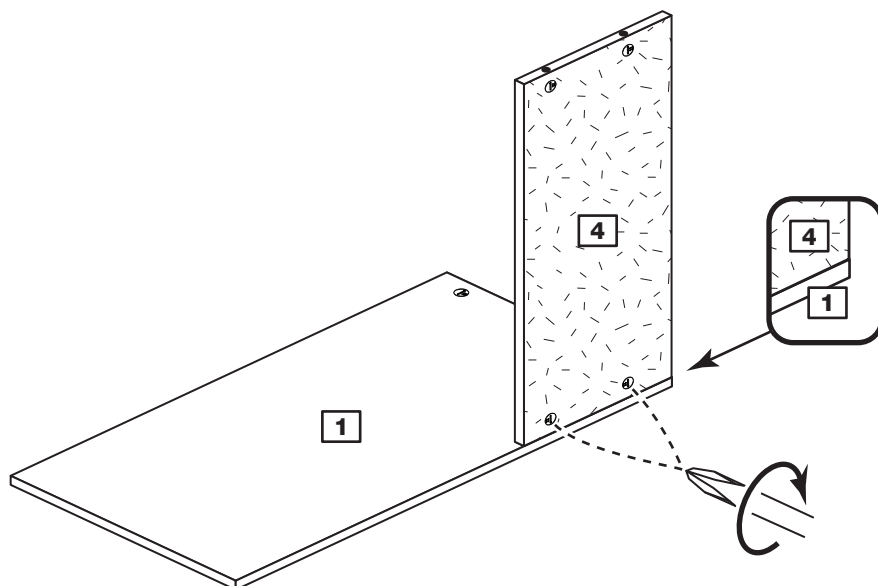

Step 17

Fit the modesty and left side assembly

Push the modesty **4** onto the upright **3**.

Use a screwdriver to tighten the 2 large locking nuts **D** fitted to the modesty **4**.

Using 2 people, carefully stand the unit up .

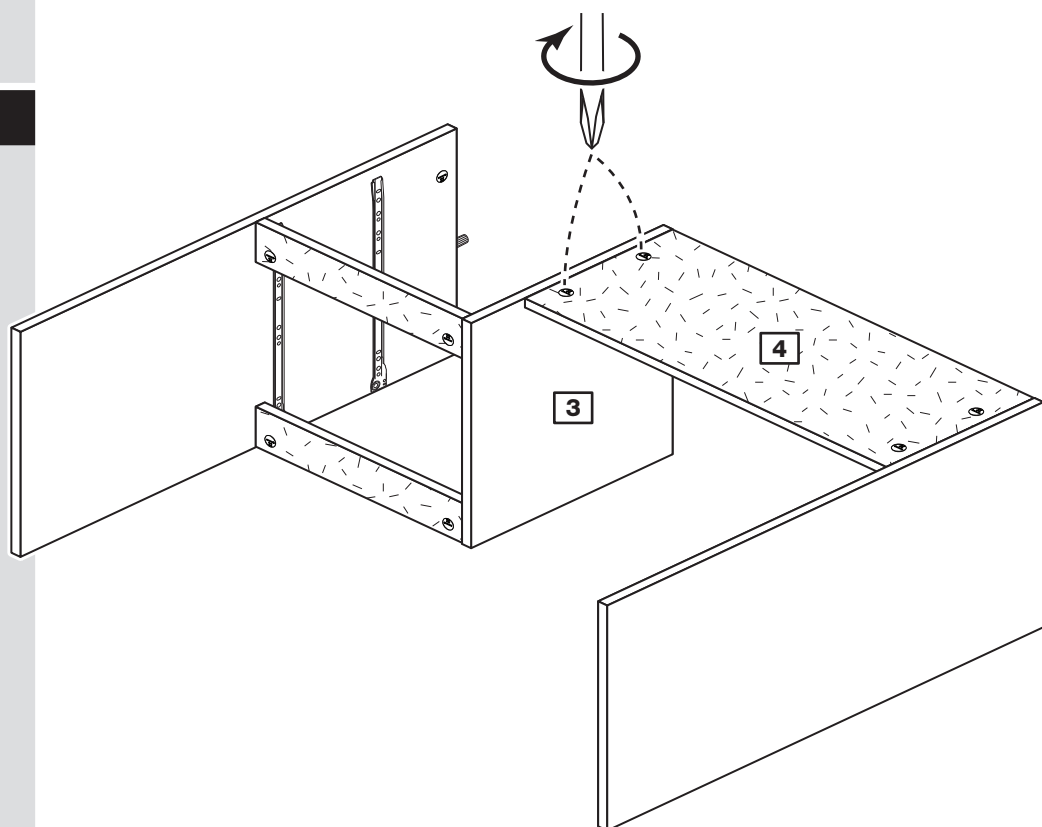

Assembly Instructions

Step 18

Prepare the top

Screw 6 metal dowels **B** into the top **7**.

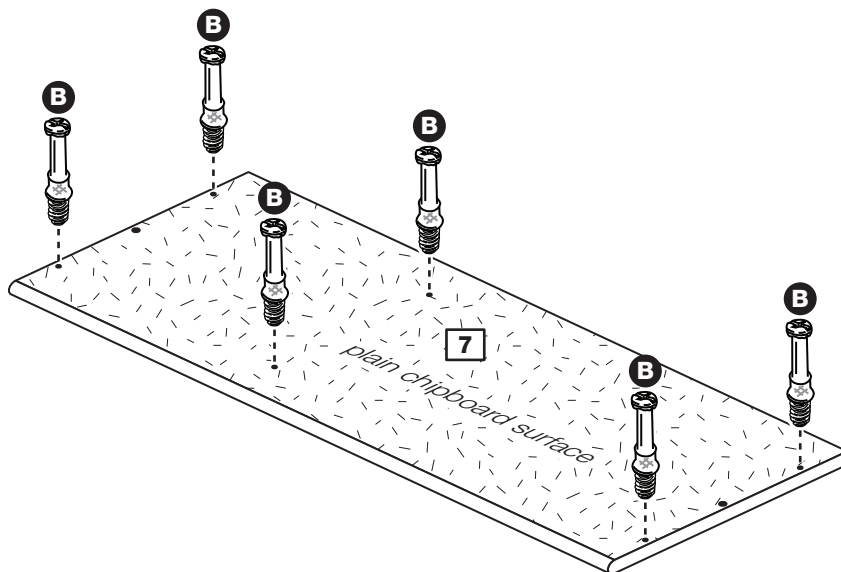

Step 19

Fit the top

Lower the top **7** down onto the assembly.

Use a screwdriver to tighten the 6 large locking nuts **D** fitted to the left side **1**, right side **2** and upright **3**.

Using 2 people, carefully lay the unit back down onto its front.

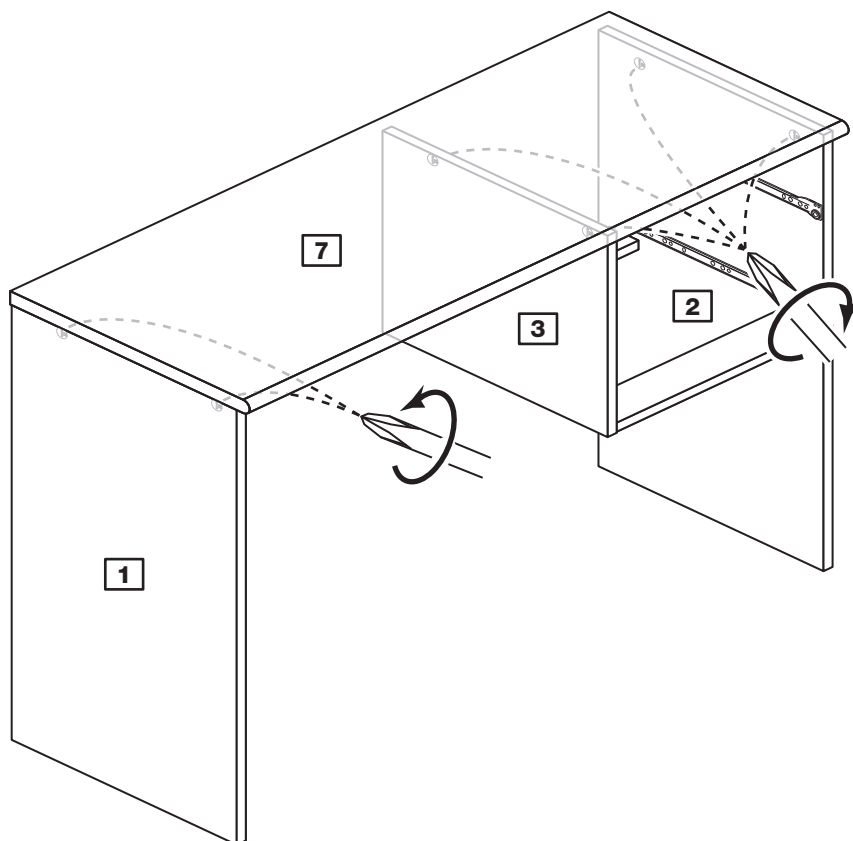

Assembly Instructions

Step 20

Fit the 4 plastic nails

Tap 2 plastic nails **Q** into the bottom edge of each of the sides **1** and **2**.

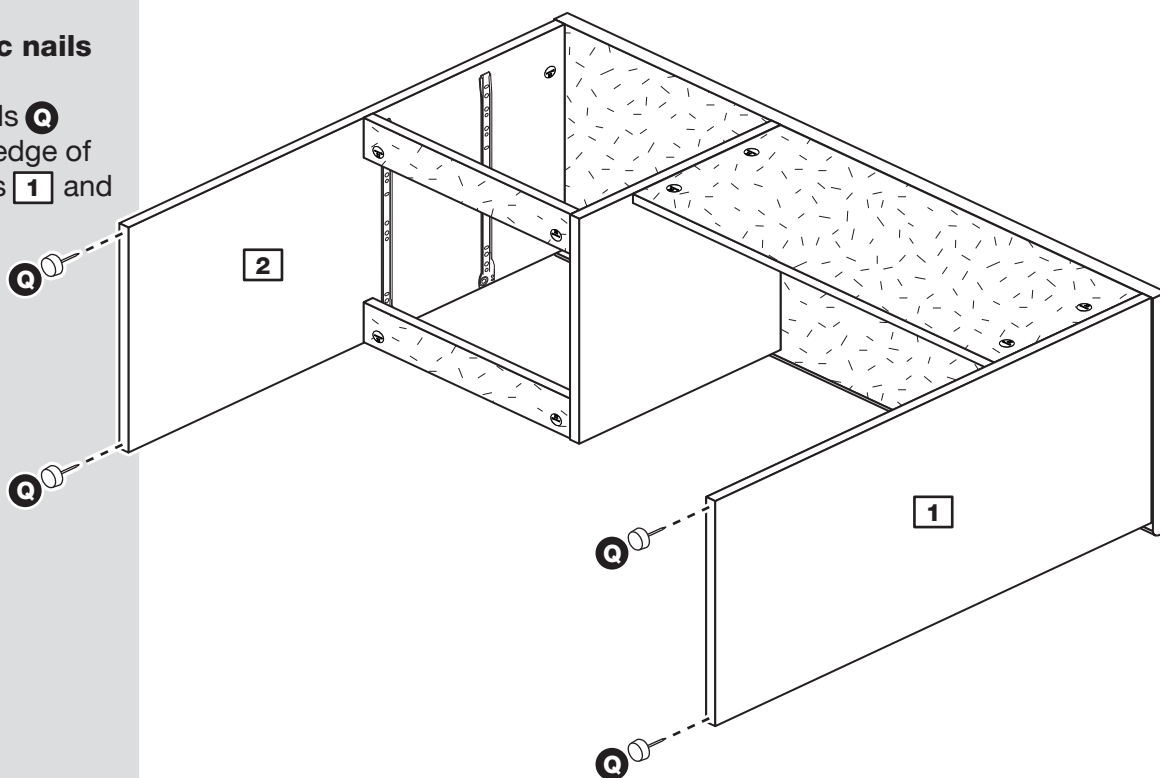

Step 21

Fit the back

a: Square up the unit by making sure that measurement **x to x** equals **y to y**.

b: Place the back **12** onto the unit.

Nail **F** around the outside edges of the back **12**.

Note: Nails should be spaced about 150mm apart.

Stand the unit up for the next step.

a: The measurement from top corner X to bottom corner X must be equal to the measurement from top corner Y to bottom corner Y

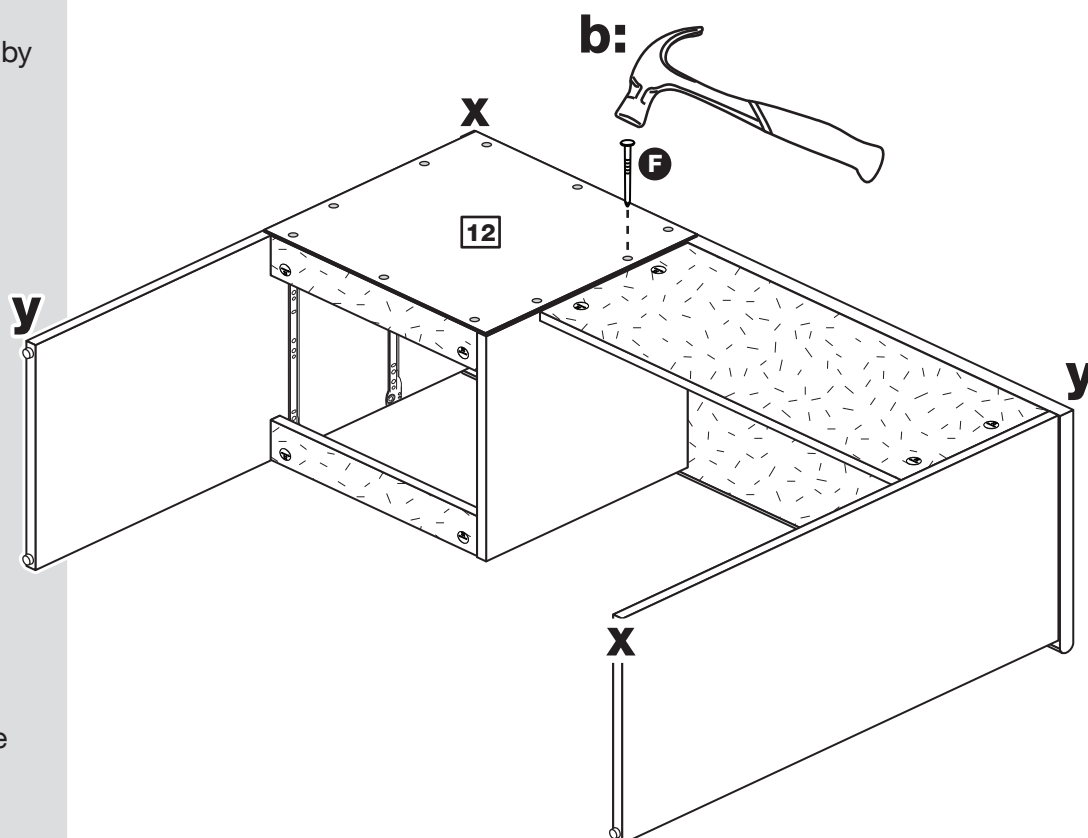

Warning: The unit is heavy. Lift with care.

Assembly Instructions

Step 22

Fit the drawers

Slide the wheels of the runners fitted to the drawers, over the wheels of the runners fitted to the side panels and push the drawers into position.

The assembly of the dresser is complete.

Follow the next steps to assemble the stool.

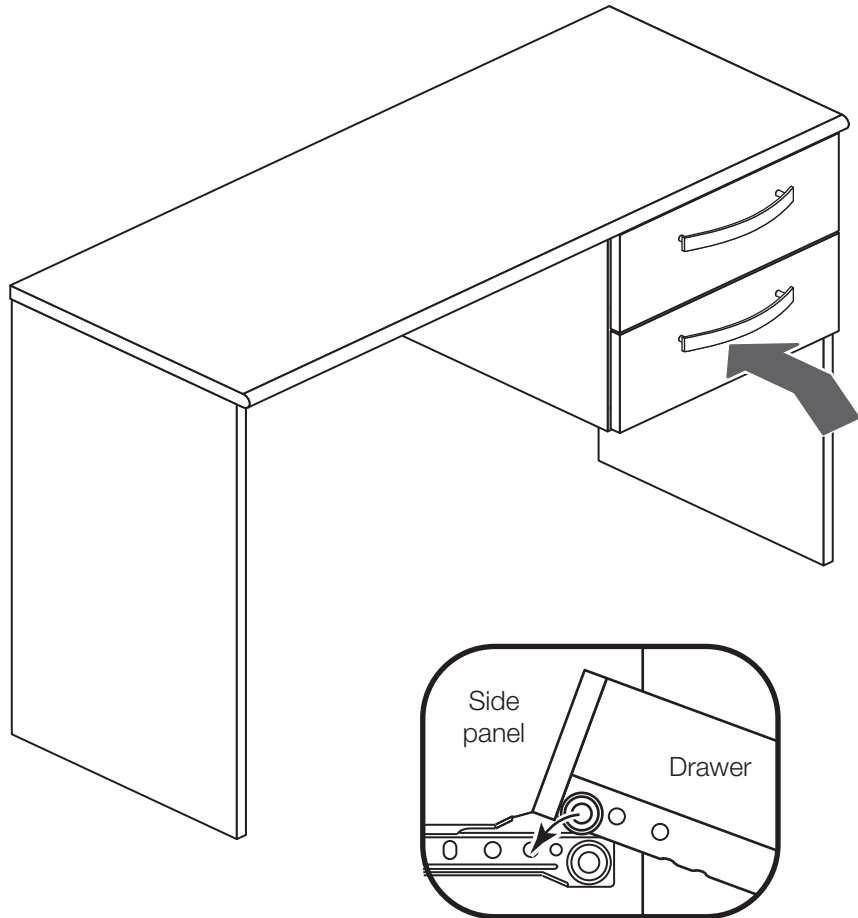

Step 23

Prepare the stool drawer front

Screw 2 metal dowels **B** into the stool drawer front **18**.

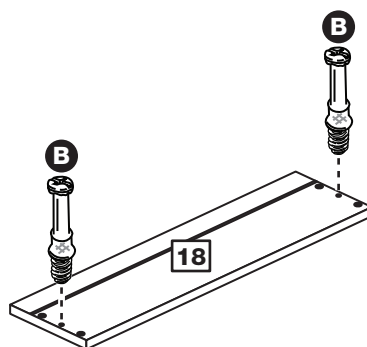

Assembly Instructions

Step 24

Prepare the stool drawer sides

Insert a small locking nut **C** into the hole shown on the stool left drawer side **19** and stool right drawer side **20**.

Note: Arrow on locking nut **must** point towards hole in edge of panel.

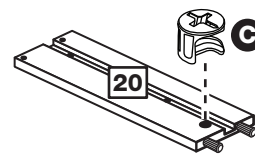
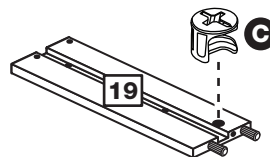
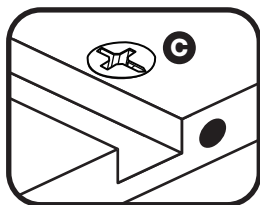

Step 25

Attach the stool drawer sides to the stool drawer front

Push the stool left drawer side **19** and stool right drawer side **20** onto the back of the stool drawer front **18**.

Turn the small locking nuts **C** on the stool left drawer side **19** and stool right drawer side **20**.

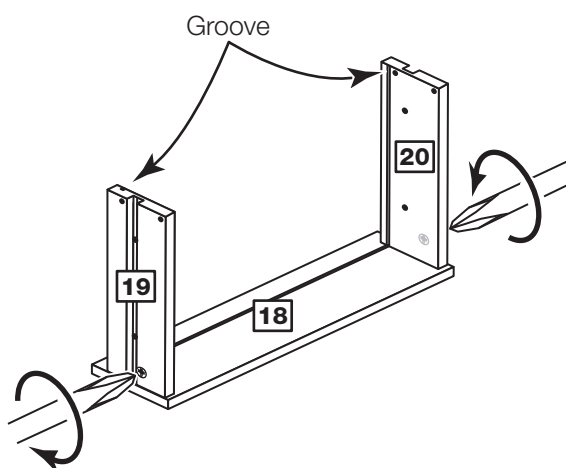
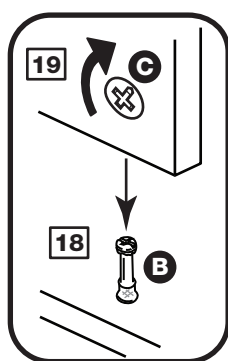

Note: The locking nuts can be on either surface of the drawer sides. Make sure that the groove is on the inside, as shown.

Step 26

Fit the stool drawer base

Slide the stool drawer base **23** down the grooves in the stool drawer sides **19** and **20** and down into the groove in the stool drawer front **18**.

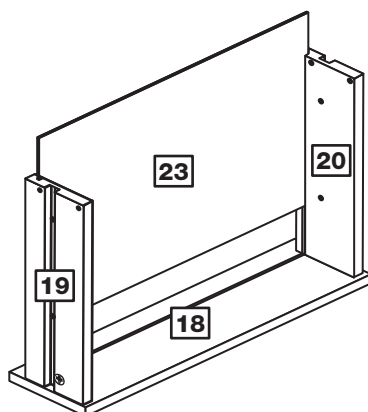

Assembly Instructions

Step 27

Fit the stool drawer back

Fit the stool drawer back **21** down onto the stool drawer base **23**.

Make sure that the stool drawer base **23** fits into the groove in the stool drawer back **21**.

Hold the stool drawer back **21** in position and tap the knock-in pegs **E** through the holes in the stool drawer sides **19** and **20**.

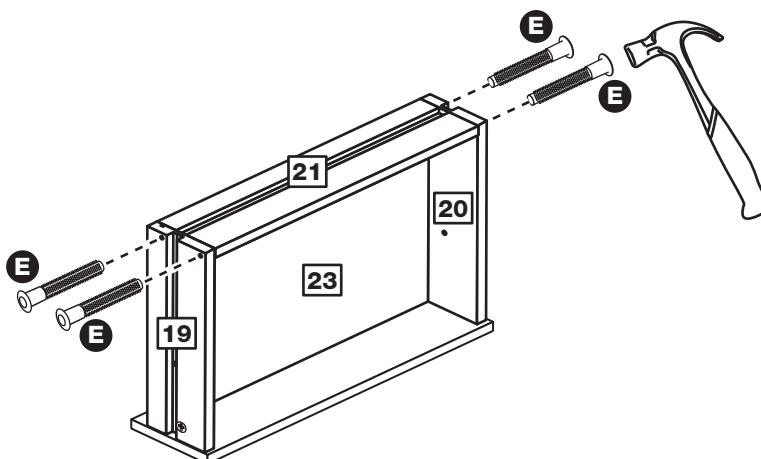

Step 28

Fit the wedgexes

Turn the drawer assembly over and slide 2 wedgexes **P** into the front and back grooves, as shown, and tighten up the screws.

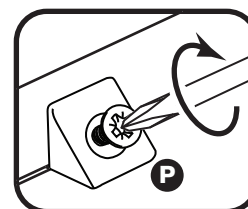
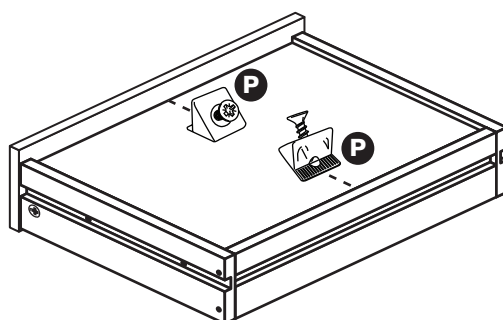

Step 29

Prepare the stool rails

Tap 2 wooden dowels **A** into each of the stool rails **17**.

Insert 4 large locking nuts **D** into each of the stool rails **17**.

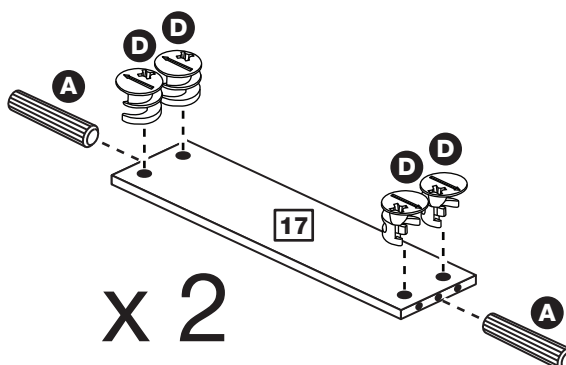

Assembly Instructions

Step 30

Prepare the stool left side

a: Place a runner **N** onto the stool left side **13**. Slide back the top of runner and use the 2nd hole from the front to fit the 1st screw **K**.

b: Slide the runner back the other way and use the 2nd hole from the back to fit the 2nd screw **K**.

c: Screw 6 metal dowels **B** into the stool left side **13**.

d: Tap a wooden dowel **A** into the stool left side **13**.

Insert 2 large locking nuts **D** into the stool left side **13**.

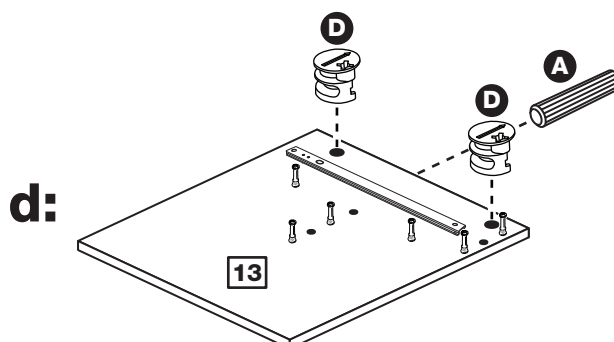
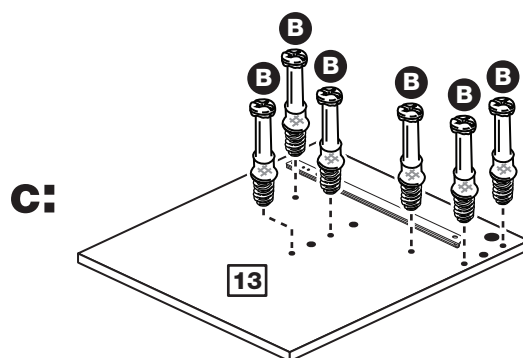
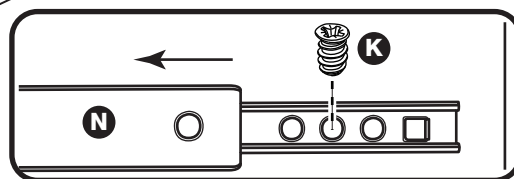
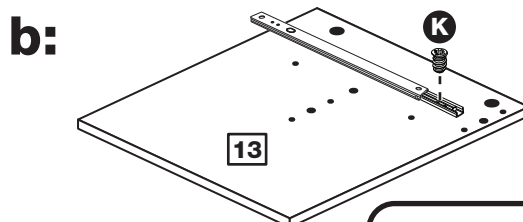
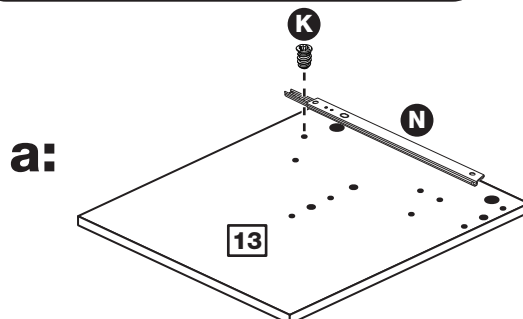
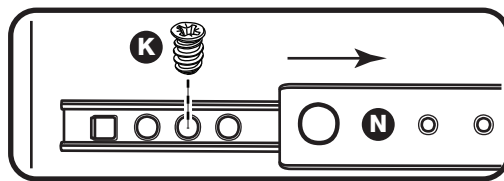

Assembly Instructions

Step 31

Prepare the stool right side

a: Place a runner **N** onto the stool right side **14**. Slide back the top of runner and use the 2nd hole from the front to fit the 1st screw **K**.

b: Slide the runner back the other way and use the 2nd hole from the back to fit the 2nd screw **K**.

c: Screw 6 metal dowels **B** into the stool right side **14**.

d: Tap a wooden dowel **A** into the stool right side **14**.

Insert 2 large locking nuts **D** into the stool right side **14**.

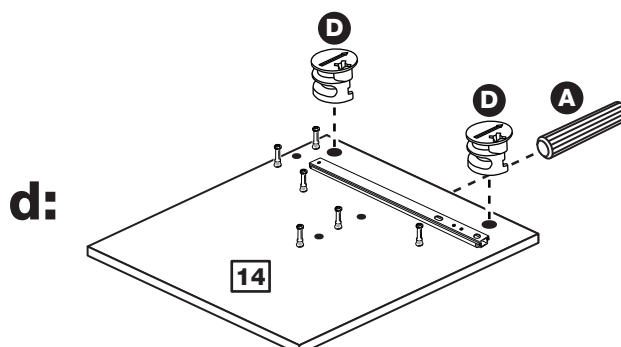
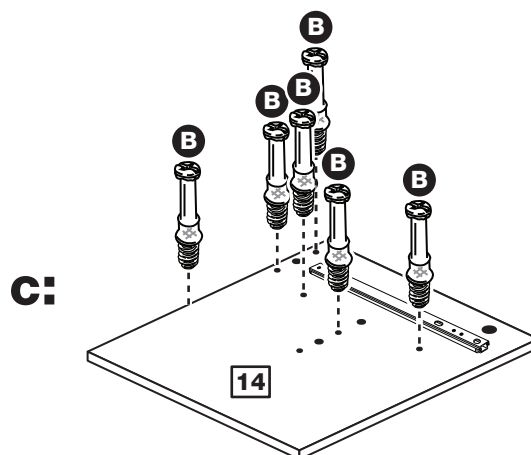
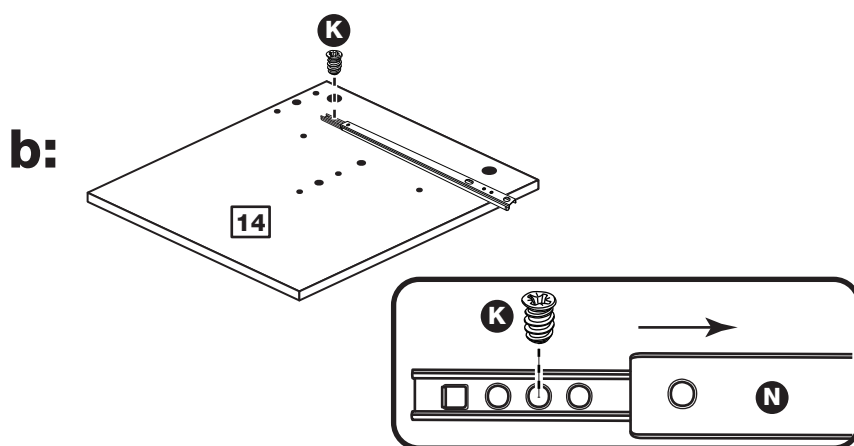
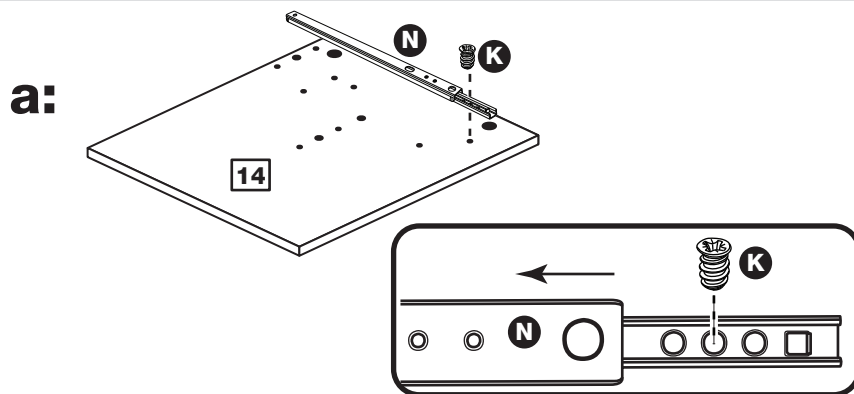

Assembly Instructions

Step 32

Fit a stool rail to the stool left side

Push a stool rail **17** onto the stool left side **13**.

Use a screwdriver to tighten the 2 large locking nuts **D** fitted to the stool rail **17**.

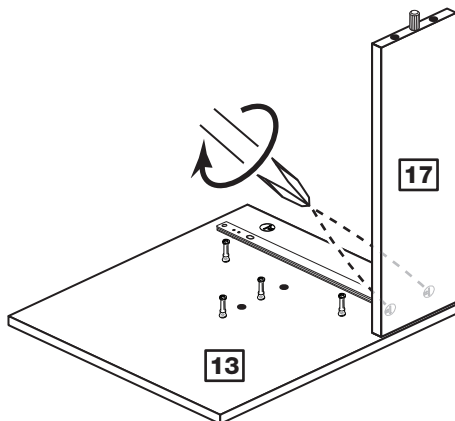

Step 33

Prepare the stool base

Tap 2 wooden dowels **A** into the stool base **16**.

Insert 4 large locking nuts **D** into the stool base **16**.

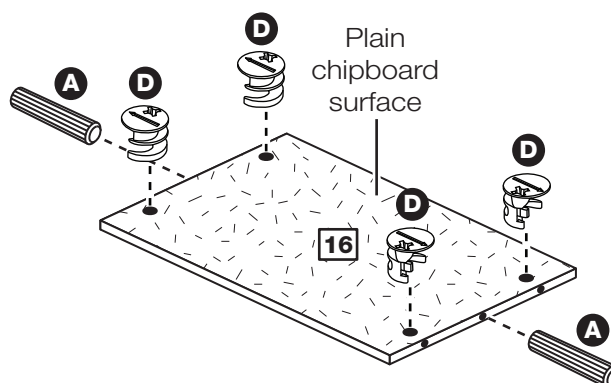

Step 34

Fit the stool base

Push the stool base **16** onto the stool left side **13**.

Use a screwdriver to tighten the 2 large locking nuts **D** fitted to the stool base **16**.

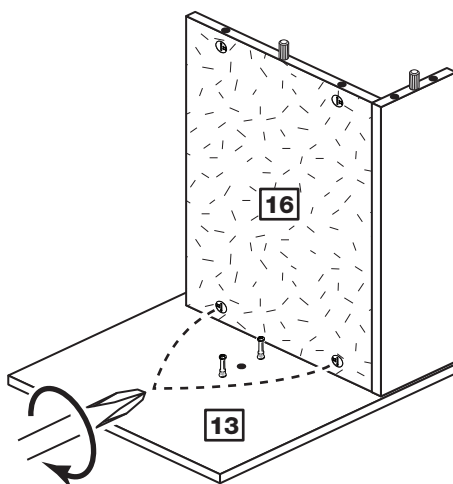

Assembly Instructions

Step 35

Fit the other stool rail

Push the other stool rail **17** onto the stool left side **13**.

Use a screwdriver to tighten the 2 large locking nuts **D** fitted to the stool rail **17**.

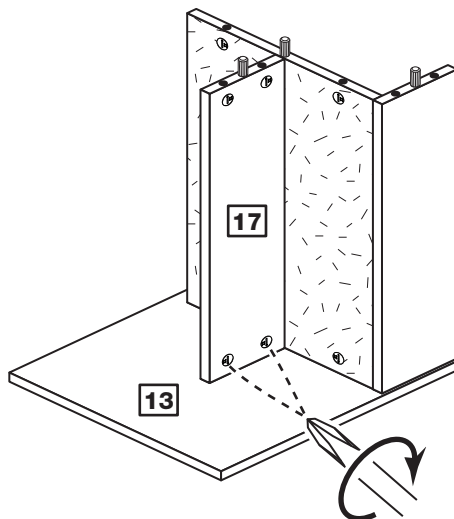

Step 36

Fit the stool right side

Push the stool right side **14** onto the stool base **16** and the 2 stool rails **17**.

Use a screwdriver to tighten the 2 large locking nuts **D** fitted to each of the stool rails **17**.

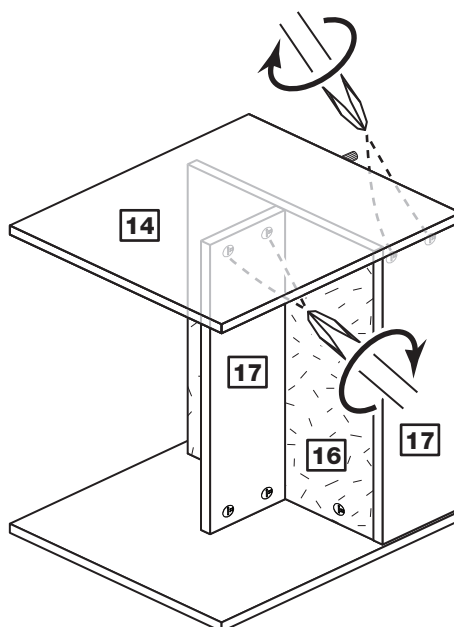

Step 37

Secure the stool base

Use a screwdriver to tighten the 2 large locking nuts **D** fitted to the stool base **16**.

Stand the stool up for the next step.

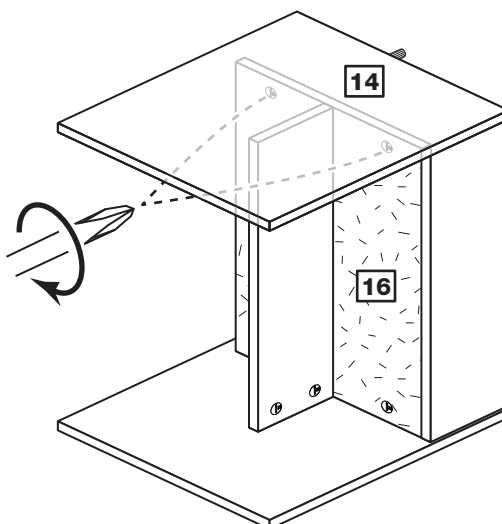

Assembly Instructions

Step 38

Fit the 4 plastic nails

Tap 2 plastic nails **Q** into the bottom edge of each of the stool sides **13** and **14**.

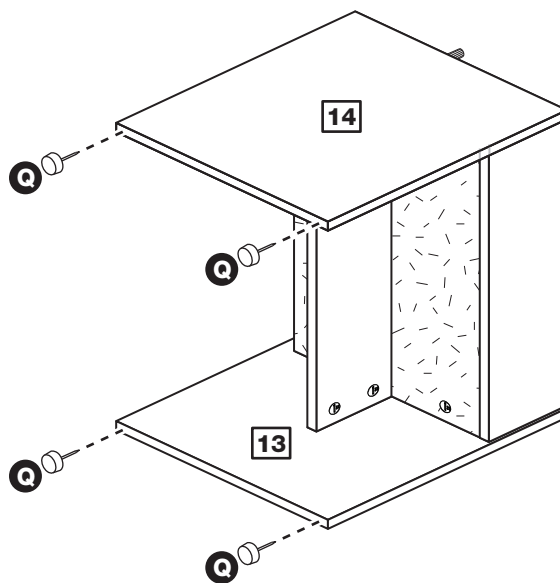

Step 39

Prepare the stool top

Screw 4 metal dowels **B** into the stool top **15**.

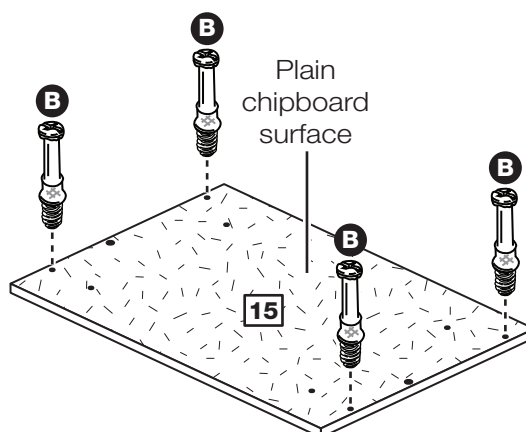

Step 40

Fit the stool seat pad

Fit the stool seat pad **22** to the stool top **15** using 4 screws **L**.

Note: Make sure that you screw into the hard surface of the stool seat pad.

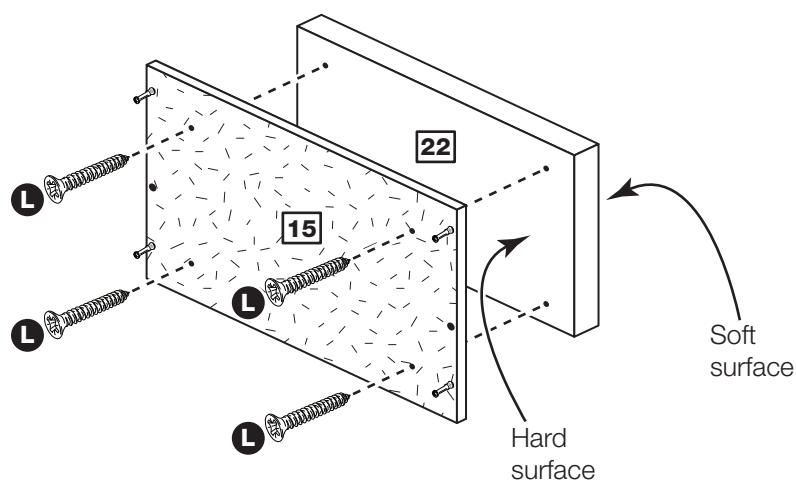

Assembly Instructions

Step 41

Fit the stool top

Lower the stool top **15** down onto the assembly.

Use a screwdriver to tighten the 4 large locking nuts **D** fitted to the stool left side **13** and stool right side **14**.

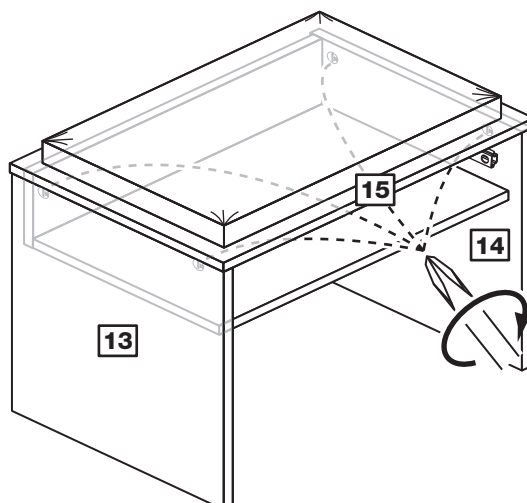

Step 42

Fit the stool drawer

Slide both the runners **N** forward and locate the drawer sides **19** and **20** between them, lining up the holes in the drawer sides with the 2nd 'threaded' holes in the runners **N**.

Working from the inside of the drawer, insert 2 screws **J** through the drawer sides and out into the 2nd threaded hole in the runner.

Note: Do not overtighten the screws **J**. If they catch on the runner you may need to loosen them slightly.

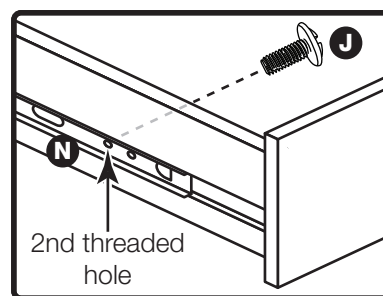
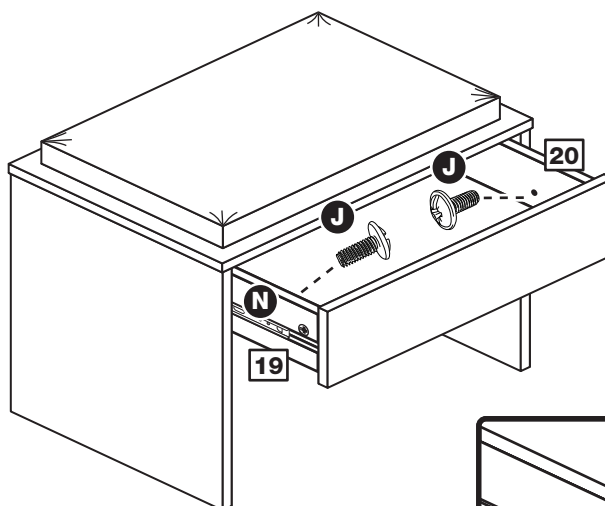

Assembly Instructions

Step 43

Assembly is complete

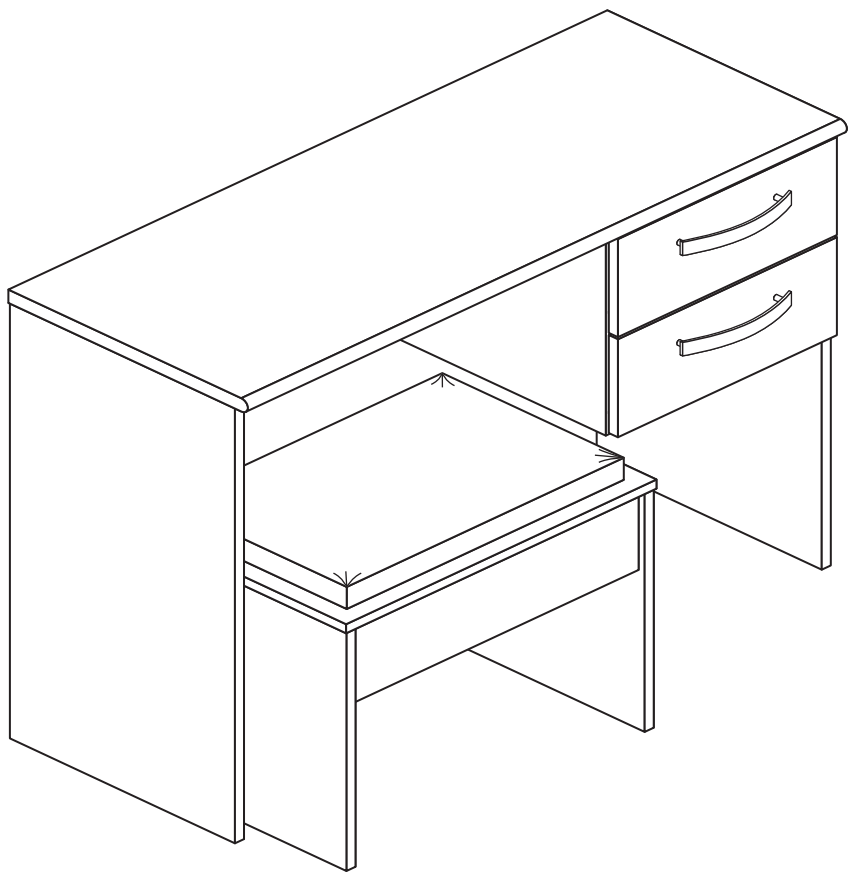

If you need help or have damaged or missing parts, call the **Customer Helpline: 0870 112 1928**
or email: **Help@ClickSpares.co.uk** (quoting your original order number and the reference numbers on the component pages)
Argos Ltd, 489-499 Avebury Boulevard, Central Milton Keynes, MK9 2NW

