

# Glass Top Coffee Table

Assembly Instructions - Please keep for future reference

246/4675

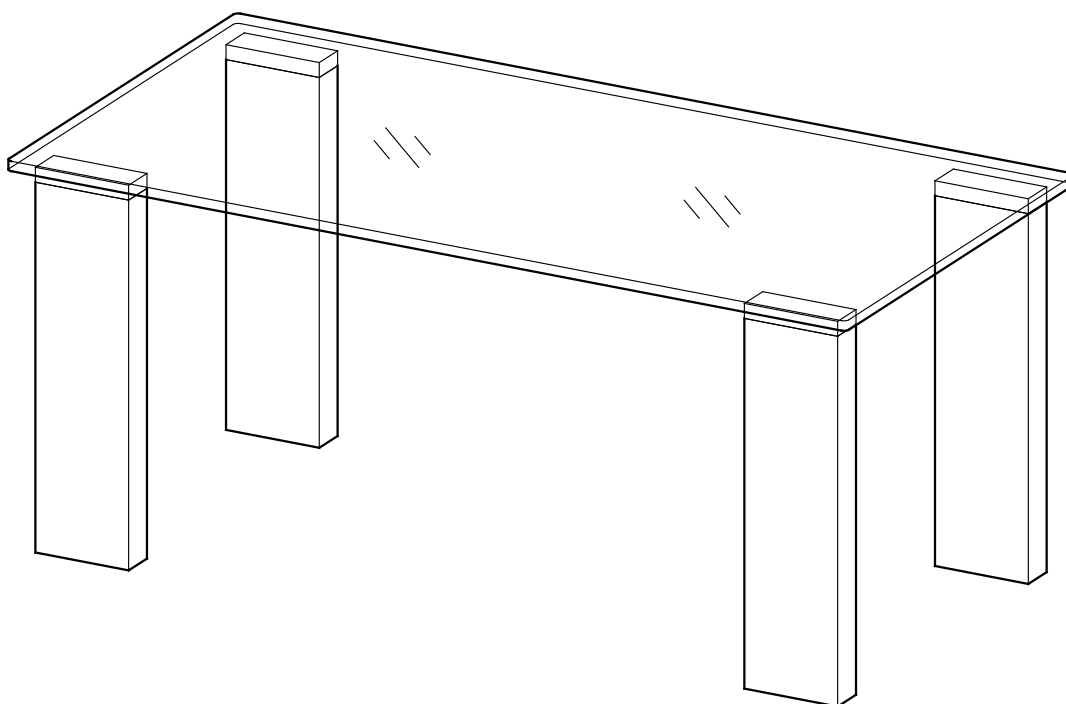

## Dimensions

Width - 90cm

Depth - 45cm

Height - 45cm

**Important** – Please read these instructions fully before starting assembly

If you need help or have damaged or missing parts, call the Customer Helpline: 08456 400800



# Safety and Care Advice

**Important** – Please read these instructions fully before starting assembly

- Check you have all the components and tools listed on pages 2.
- Remove all fittings from the plastic bags and separate them into their groups.
- Keep children and animals away from the work area, small parts could choke if swallowed.
- Make sure you have enough space to layout the parts before starting.

- Do not stand or put weight on the product, this could cause damage.
- Assemble the item as close to its final position (in the same room) as possible.
- Assemble on a soft level surface to avoid damaging the unit or your floor.



- We do not recommend the use of power drill/drivers for inserting screws, as this could damage the unit. Only use hand screwdrivers.
- Dispose of all packaging carefully and responsibly.

**Glass safety** – Take care when handling glass, please follow the advice below

- If a glass component is chipped or broken replace with glass of the type described on this instructions. Consult the manufacturer, retailer or agent with regard to obtaining a manufacturing specification and shape for replacement glass quoting the model number, and batch or date of manufacture.

- Do not place very hot or cold items against or in close proximity to the glass surfaces unless adequately thick insulating material is used to prevent such items coming into contact with the glass.
- Do not strike the glass with hard or pointed items.

- When cleaning glass panels or mirrors use a damp cloth or leather with washing up liquid or soft soap if necessary.
- Do not use washing powders or any other substances containing abrasives since these substances scratch glass.

**Care and maintenance**

- Only clean using a damp cloth and mild detergent, do not use bleach or abrasive cleaners.
- From time to time check that there are no loose screws on this unit.
- This product should not be discarded with household waste. Take to your local authority waste disposal centre.

Note: if required the next page can be cut out and used as reference throughout the assembly. Keep this page with these instructions for future reference.

# Components - Panels

Please check you have all the panels listed below

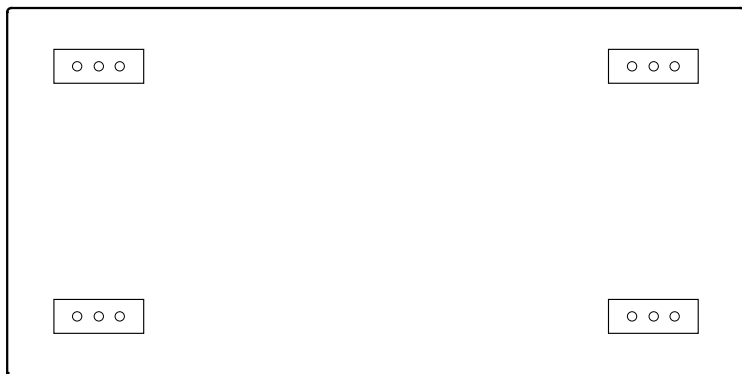

**1** Top glass panel



**2** Bolt







**3** Leg

# Components - Fittings

If you have damaged or missing components, call the **Customer Helpline: 08456 400800**

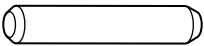
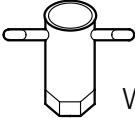
Please check you have all the fittings listed below

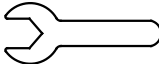
**Note:** The quantities below are the correct amount to complete the assembly. In some cases more fittings may be supplied than are required.

<p><b>A</b> </p> <p>Wood dowel x 8</p>	<p><b>B</b> </p> <p>Wrench x 1</p>	<p><b>C</b> </p> <p>Washer x 4</p>
<p><b>D</b> </p> <p>Nut x 8</p>	<p><b>E</b> </p> <p>Spanner x 1</p>	<p><b>F</b> </p> <p>Foot pad x 4</p>

## Tools required

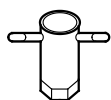

Wrench  
(Provided)

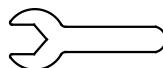

Spanner  
(Provided)

# Assembly Instructions

## Step 1

### Fitting nuts and dowels

Screw nut **D** to one head of Bolt **2**. Screw nut on by approximate 15mm.

Firmly push wooden dowels **A** into indicated holes in Leg **3**.

**Repeat this step for other 3 Bolts and other 3 Legs.**

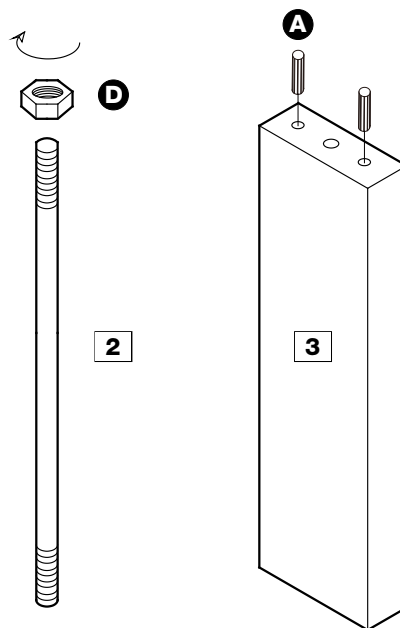

## Step 2

### Attaching Bolts

Lay the Top glass panel **1** upside down on a soft surface.

Screw end of bolt with nut on into the centre hole of the blocks on Top Glass panel **1** until hand tight.

Turn the nut against the metal block firmly as shown.

**Note:** Use Spanner **E** to tighten the nut.

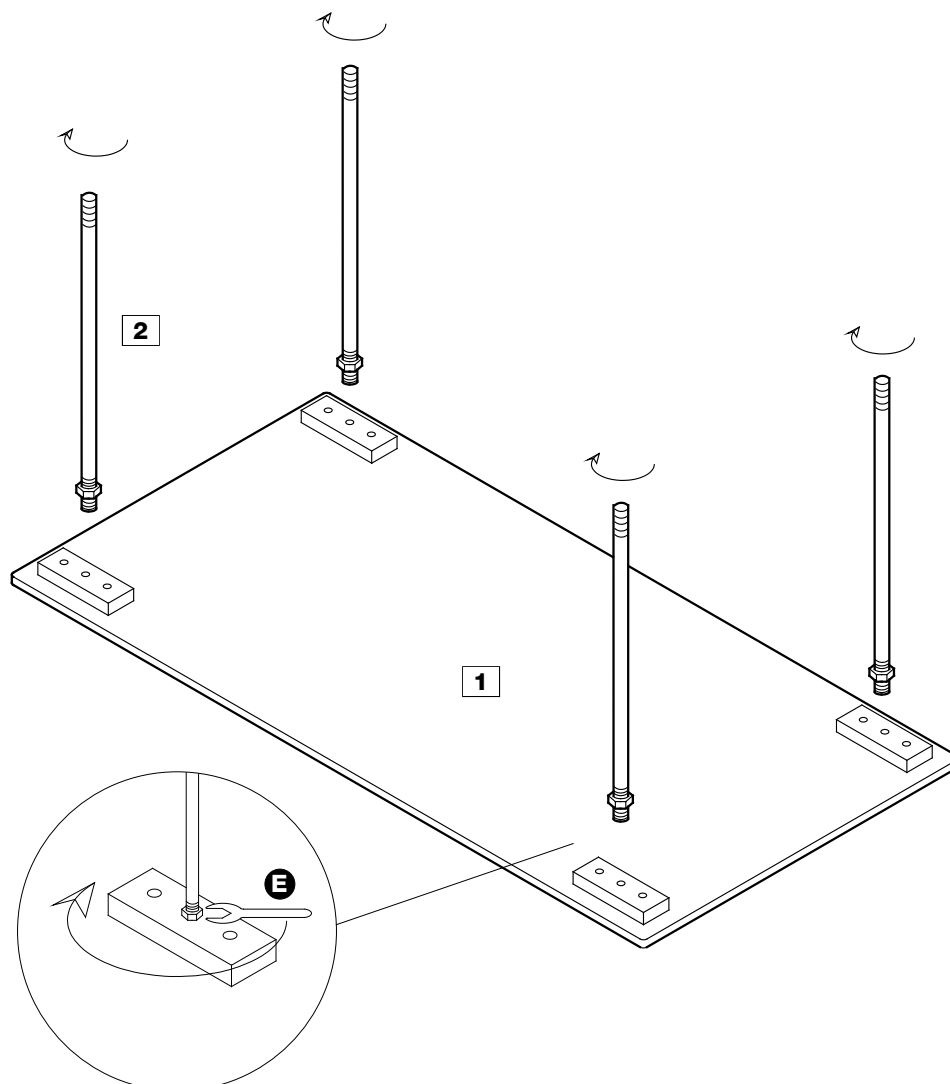

# Assembly Instructions

## Step 3

Firmly push Legs **3** onto the Bolts **2**, make sure the wood dowels enter corresponding holes in the top panel blocks.

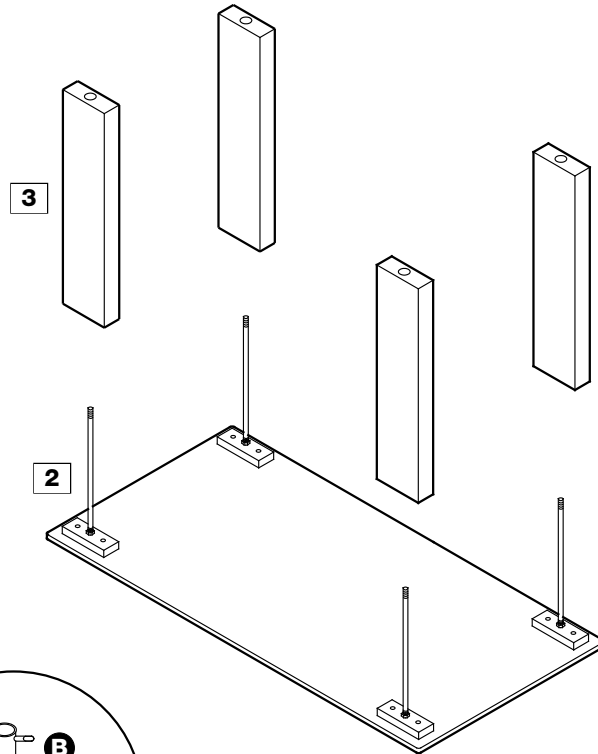

## Step 4

Put one Washer **C** onto each bolt head, screw Nut **D** on the head of bolt, tighten with Wrench **B**.

Peel off the cover of the Foot pad **F**, attach to the end of Leg **3**.

Turn the table upright.

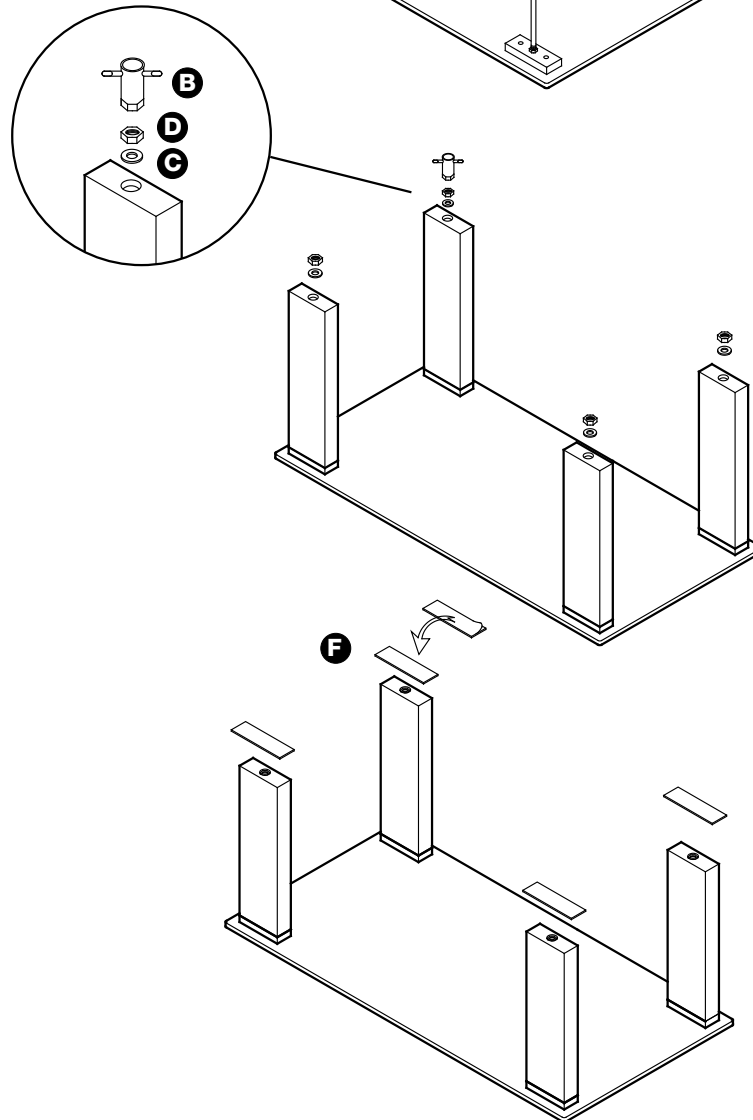

**Assembly is complete.**

If you need help or have damaged or missing parts, call the **Customer Helpline: 08456 400800**  
Shaw Spencer Hometrading Ltd. 34-38 Vale Road, Bushey. WD23 2HE.