

Denver - 1 Drawer Bedside

Assembly Instructions - Please keep for future reference

352/9045

357/9040

339/5846

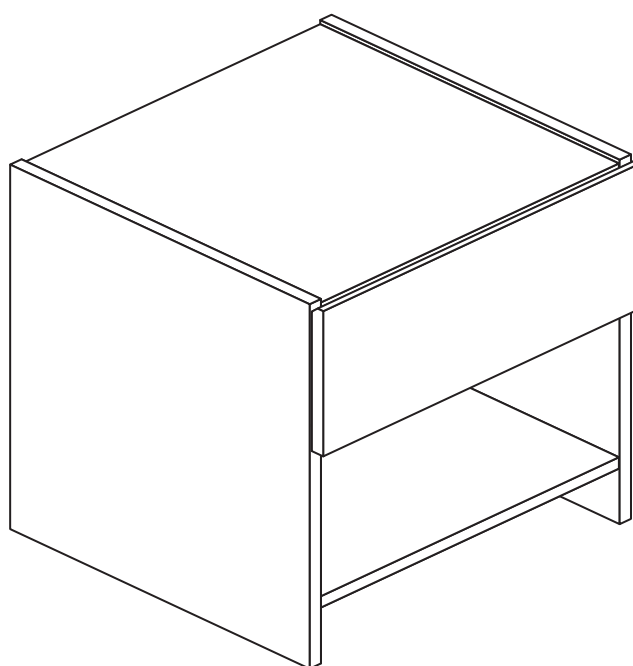

Dimensions

Width - 41cm

Depth - 40cm

Height - 49cm



**MADE IN
BRITAIN**

Important - Please read these instructions fully before starting assembly

If you need help or have damaged or missing parts, call the **Customer Helpline: 08456 400800**



Safety and Care Advice

Important - Please read these instructions fully before starting assembly

- **Warning:** This unit weighs approximately 10kgs. Please lift with care.

- Check you have all the components and tools listed on pages 2 and 3.

- Remove all fittings from the plastic bags and separate them into their groups.

- Keep children and animals away from the work area, small parts could choke if swallowed.

- Parts of the assembly will be easier with 2 people.

- Make sure you have enough space to layout the parts before starting.

- Do not stand or put weight on the product, this could cause damage.

- Assemble the item as close to its final position (in the same room) as possible.

- Assemble on a soft level surface to avoid damaging the unit or your floor (use opened out unit carton).



- We do not recommend the use of power drill/drivers **for inserting screws**, as this could damage the unit. Only use hand screwdrivers.

- **Safety note:** If there is any chance of this unit being pulled over by children etc. it is recommended that the unit is secured to a wall using suitable fixings (not supplied).

- Dispose of all packaging carefully and responsibly.

Care and maintenance

- Only clean using a damp cloth and mild detergent, do not use bleach or abrasive cleaners.

- From time to time check that there are no loose screws on this unit.

- This product should not be discarded with household waste. Take to your local authority waste disposal centre.

Note: If required the next page can be cut out and used as reference throughout the assembly. Keep this page with these instructions for future reference.

Components - Panels

If you have damaged or missing components, call the **Customer Helpline: 08456 400800** quoting the reference numbers below

Please check you have all the panels listed below

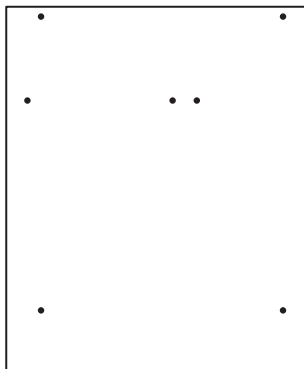

1 Left Side (DF1875)
(482 x 396mm)

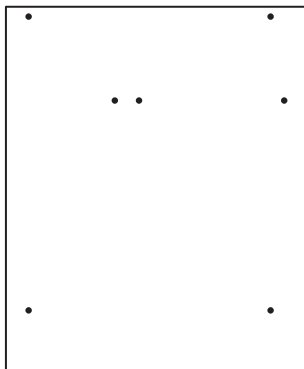

2 Right Side (DF1876)
(482 x 396mm)

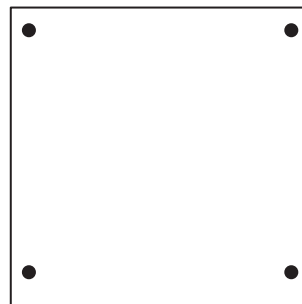

3 Top/Base (D1560A)
(395 x 395mm) x 2

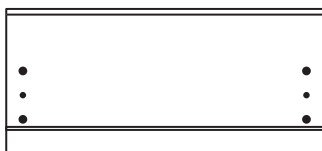

4 Drawer Front (DF418)
(419 x 192mm)



5 Left Drawer Side (W370-124LH)
(370 x 124mm)



6 Right Drawer Side (W370-124RH)
(370 x 124mm)



7 Drawer Back (W362-124)
(362 x 124mm)

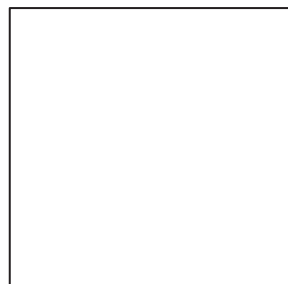

8 Drawer Base (T373-367)
(373 x 367mm)

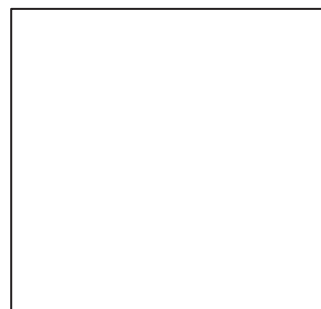

9 Back (X421-399)
(421 x 399mm)









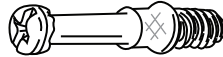

Components - Fittings

If you have damaged or missing components, call the **Customer Helpline: 08456 400800** quoting the reference numbers below

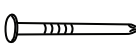
Please check you have all the fittings listed below

Note: The quantities below are the correct amount to complete the assembly. In some cases more fittings may be supplied than are required.

<p>A </p> <p>Plastic Nail (F91) x 4</p>	<p>B </p> <p>Metal dowel (F901) x 10</p>	<p>C </p> <p>Small locking nut (F3) x 2</p>
<p>D </p> <p>Large locking nut (F900) x 8</p>	<p>E </p> <p>9mm Screw (F74) x 2</p>	<p>F </p> <p>9mm Screw (F73) x 4</p>
<p>G </p> <p>Nail (F51) x 12</p>	<p>H </p> <p>Knock-in Peg (F171GY) x 4</p>	<p>I </p> <p>Wedgefix (F639) x 2</p>
<p>J </p> <p>Drawer runner (F1004) x 2</p>		

Tools required



Rule



Cross-head screwdriver



Scissors



Hammer



Eye protection (when using a hammer or drill)

Ruler - Use this ruler to help correctly identify the screws

mm 10 20 30 40 50 60 70 80 90 100 110 120 130 140 150 160 170

Assembly Instructions

If you have damaged or missing components, call the
Customer Helpline: 08456 400800 quoting the reference
numbers below

Step 1

Prepare the drawer front

Screw 2 metal dowels **B** into the drawer front **4**.

Note: Tighten the metal dowels up fully against the panels.

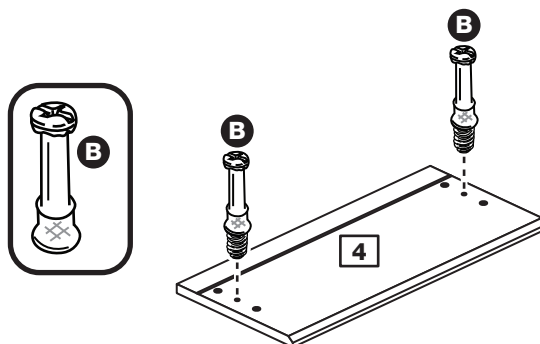

Step 2

Prepare the drawer sides

Insert a small locking nut **C** into the hole shown on the left drawer side **5** and the right drawer side **6**.

Note: The arrow on the locking nut **must** point towards the hole in the edge of the panel.

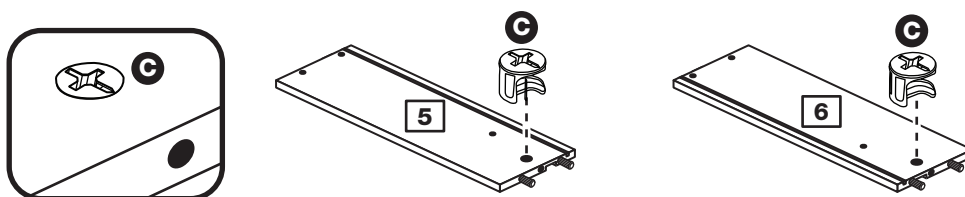

Step 3

Attach the drawer sides to the drawer front

Push the left drawer sides **5** and right drawer sides **6** onto the back of the drawer front **4**.

Turn the small locking nuts **C** on the left drawer side **5** and right drawer side **6**.

Note: Turn the locking nuts **C** clockwise to secure panels - more than 1/2 a turn.

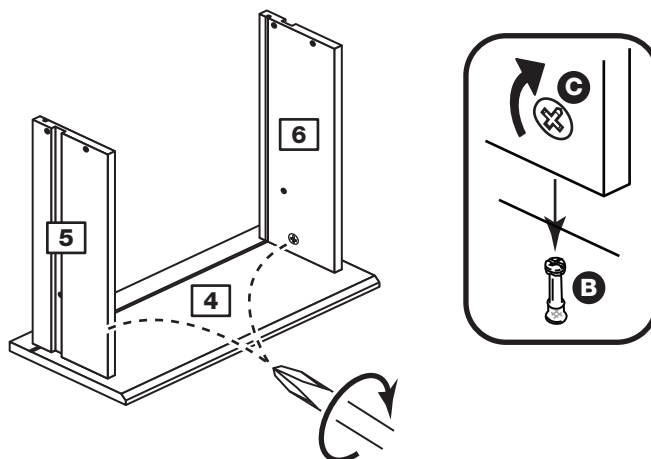

Assembly Instructions

Step 4

Fit the drawer base

Slide the drawer base **8** down the grooves in the drawer sides **5** and **6** and down into the groove in the drawer front **4**.

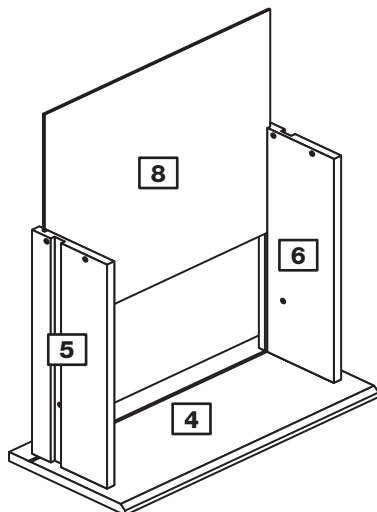

Step 5

Fit the drawer back

Fit the drawer back **7** between the drawer sides **5** and **6**. Make sure that the drawer base **8** fits into the groove in the drawer back **7**.

Hold the drawer back **7** in position and tap the knock-in pegs **H** through the holes in the drawer sides **5** and **6**.

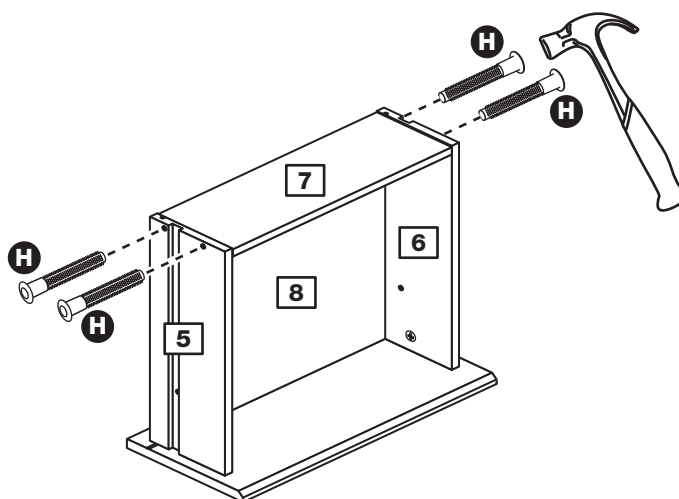

Step 6

Fit the wedgifixes

Turn the drawer assembly over and slide 2 wedgifixes **I** into the front and back grooves, as shown, and tighten up the screws.

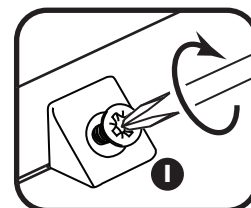
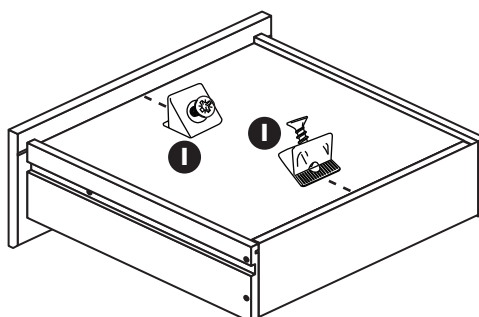

Assembly Instructions

Step 7

Prepare the left side

a: Place a runner **J** on the left side **1** as shown. Slide back the top of runner and use the 2nd hole from the front to fit the 1st screw **F**.

b: Slide the runner **J** back the other way and fit the 2nd screw **F** into the corresponding hole in the left side **1**.

Screw 4 metal dowels **B** into the left side **1**.

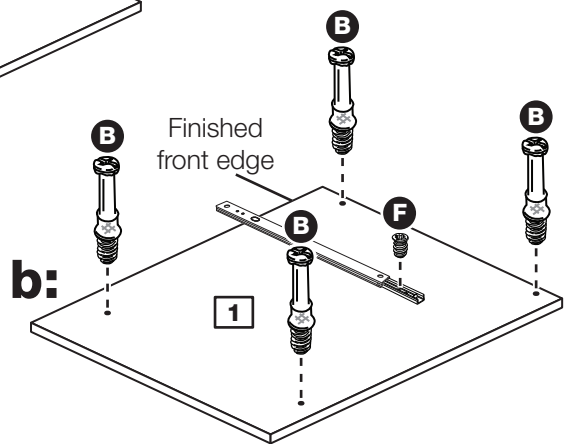
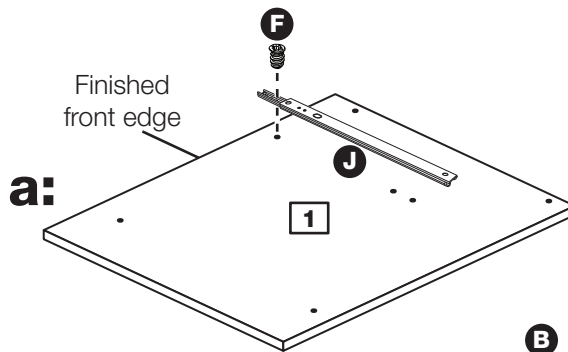
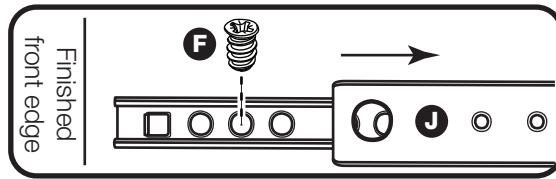

Step 8

Prepare the right side

a: Place a runner **J** on the right side **2** as shown. Slide back the top of runner and use the 2nd hole from the front to fit the 1st screw **F**.

b: Slide the runner **J** back the other way and fit the 2nd screw **F** into the corresponding hole in the right side **2**.

Screw 4 metal dowels **B** into the right side **2**.

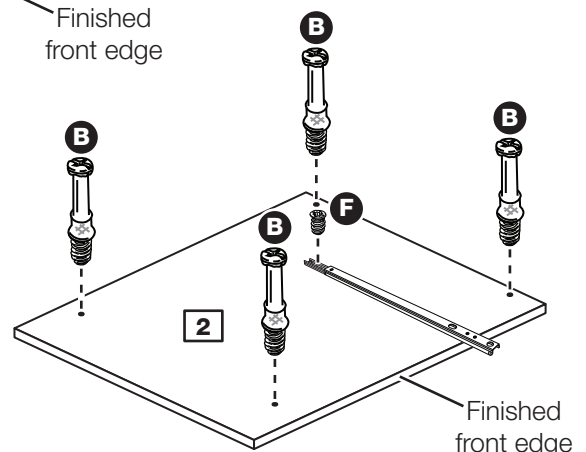
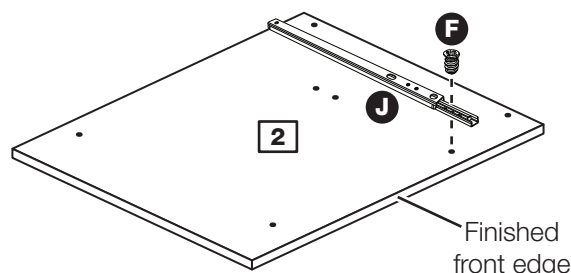
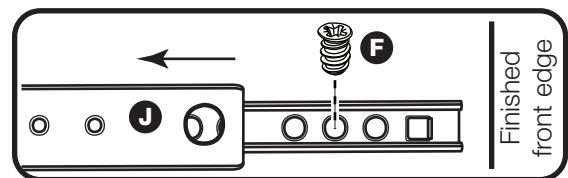

Assembly Instructions

Step 9

Prepare the top and the base

Insert 4 large locking nuts **D** into the top **3** and 4 into the base **3**.

Note: The arrow on the locking nut **must** point towards the hole in the edge of the panel.

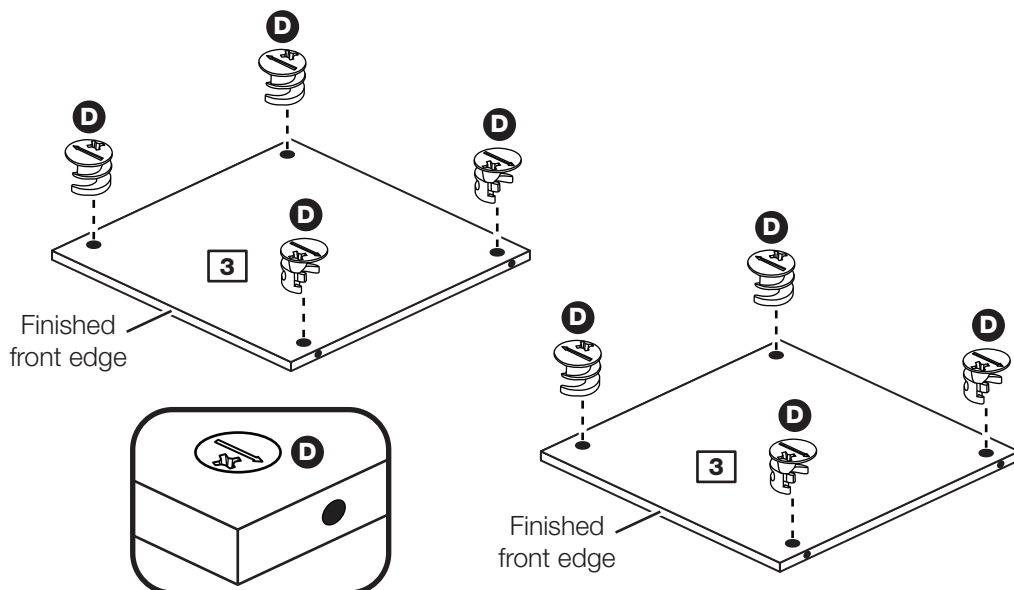

Step 10

Fit the top to the right side

Push the top **3** onto the right side **2**.

Use a screwdriver to tighten the 2 large locking nuts **D** fitted to the top **3**.

Note: Turn the large locking nuts **D** as far as they will go - more than 1/2 a turn.

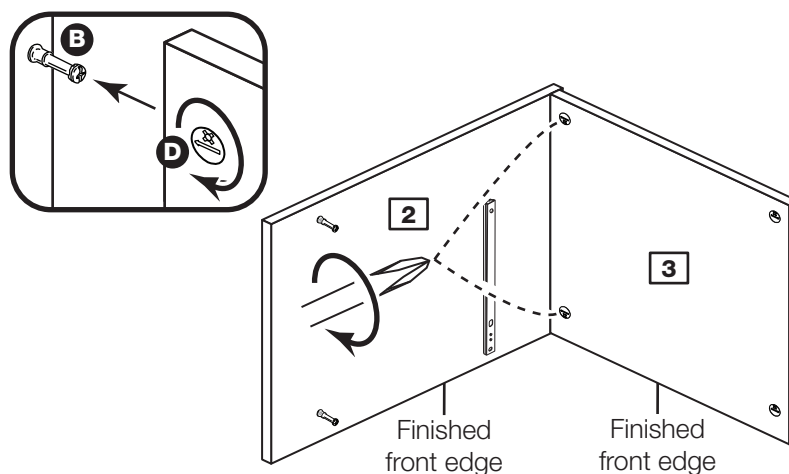

Step 11

Fit the base

Push the base **3** onto the right side **2**.

Use a screwdriver to tighten the 2 large locking nuts **D** fitted to the base **3**.

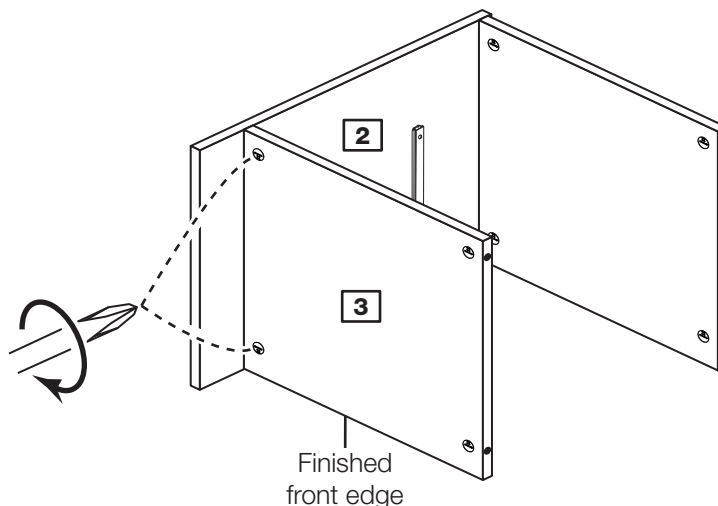

Assembly Instructions

Step 12

Fit the left side

Push the left side **1** onto the assembly.

Use a screwdriver to tighten the 4 large locking nuts **D** fitted to the top **3** and base **3**.

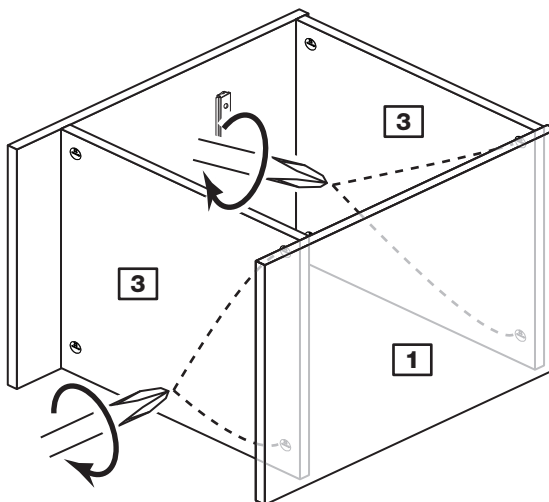

Step 13

Fit the back

a: Square up the unit by making sure that measurement **x to x** equals **y to y**.

b: Place the back **9** onto the unit.

Nail **G** around the outside edges of the back **9**.

Note: Nails should be evenly spaced out.

a: The measurement from top corner X to bottom corner X must be equal to the measurement from top corner Y to bottom corner Y

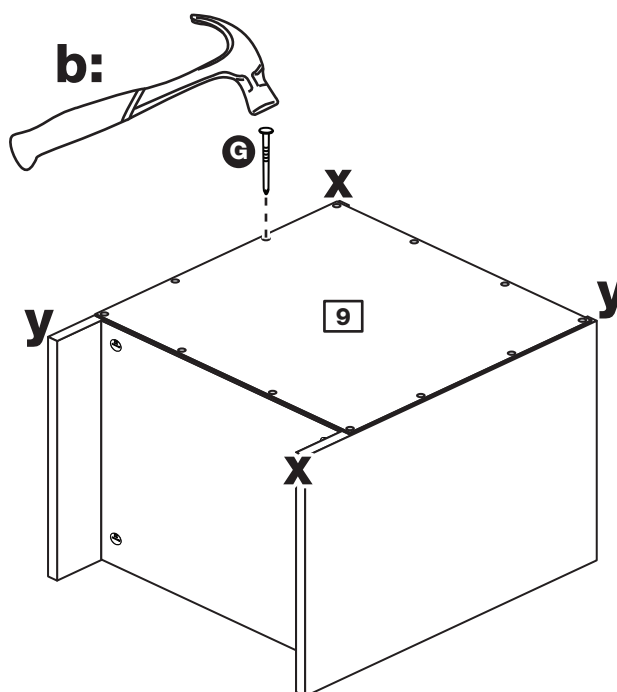

Assembly Instructions

Step 14

Fit the 4 plastic nails

Tap 2 plastic nails **A** into the bottom edge of each of the sides **1** and **2**.

Stand the unit up for the next step.

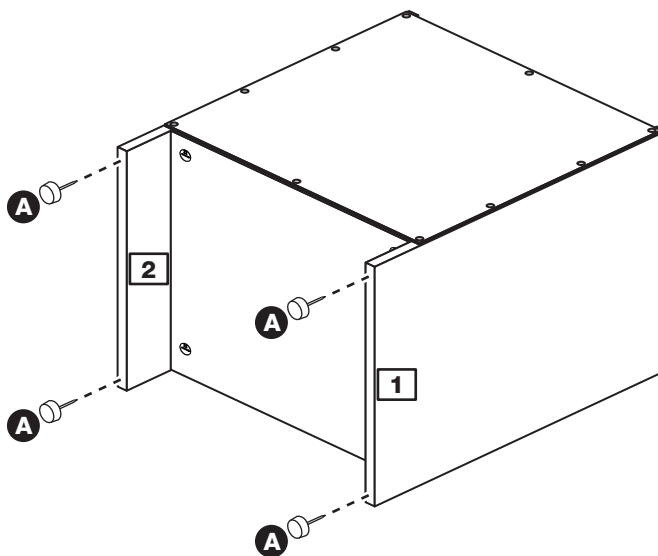

Step 15

Fit the drawer

Slide both the runners **J** forward and locate the drawer sides **5** and **6** between them, lining up the holes in the drawer wrap with the 2nd 'threaded' holes in the runners **J**.

Working from the inside of the drawer, insert 2 screws **E** through the drawer sides and out into the 2nd threaded hole in the runner.

Note: Do not overtighten the screws **E**.
If they catch on the runner you may need to loosen them slightly.

Assembly is complete

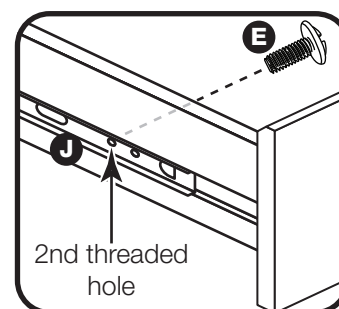
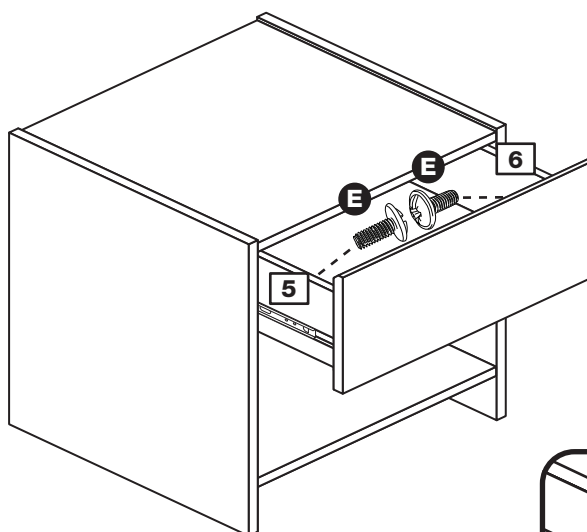

If you need help or have damaged or missing parts, call the Customer Helpline: 08456 400800 and quote the reference numbers on the component pages.

Argos Ltd, 489-499 Avebury Boulevard, Central Milton Keynes, MK9 2NW

Denver - 4 Drawer Chest

Assembly Instructions - Please keep for future reference

355/8463

333/7062

332/4790

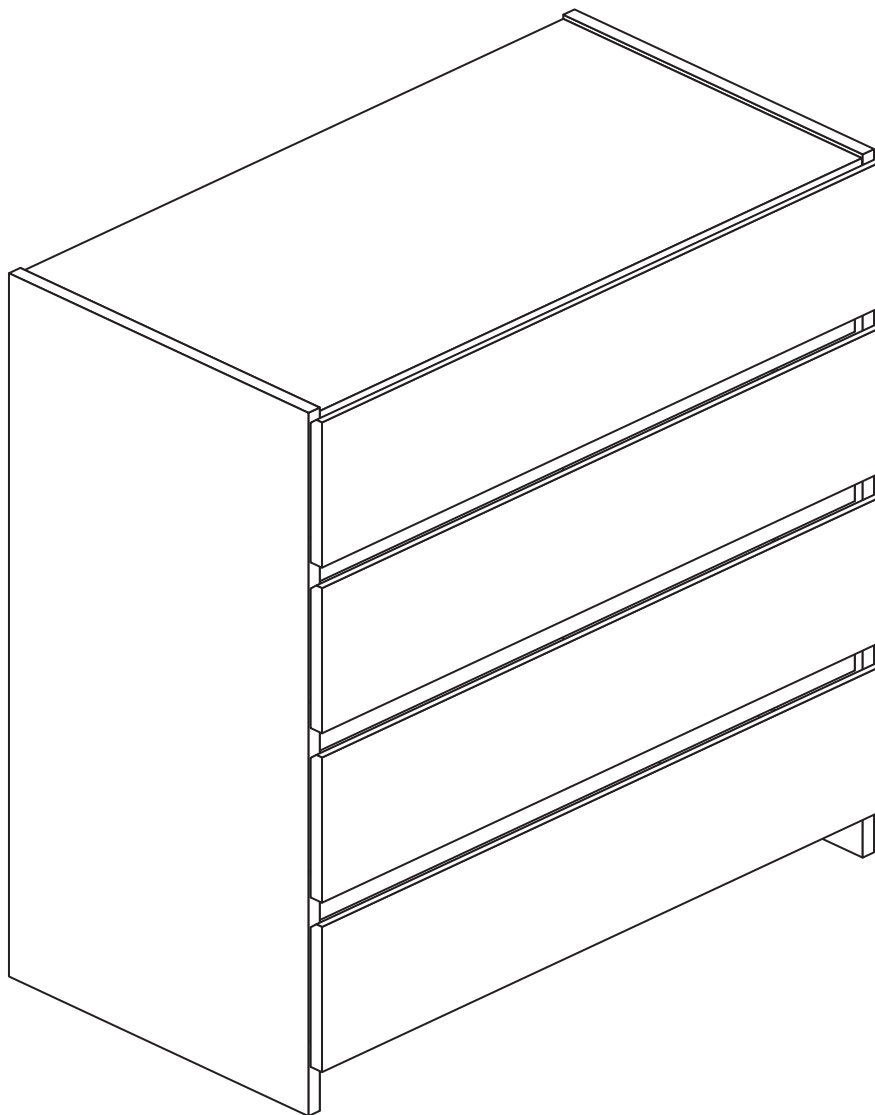

Dimensions

Width - 75cm

Depth - 40cm

Height - 93cm



**MADE IN
BRITAIN**

Important - Please read these instructions fully before starting assembly

If you need help or have damaged or missing parts, call the **Customer Helpline: 08456 400800**



Safety and Care Advice

Important - Please read these instructions fully before starting assembly

- **Warning:** This unit weighs approximately 29kgs. Please lift with care.

- Check you have all the components and tools listed on pages 2 and 3.

- Remove all fittings from the plastic bags and separate them into their groups.

- Keep children and animals away from the work area, small parts could choke if swallowed.

- Parts of the assembly will be easier with 2 people.

- Make sure you have enough space to layout the parts before starting.

- Do not stand or put weight on the product, this could cause damage.

- Assemble the item as close to its final position (in the same room) as possible.

- Assemble on a soft level surface to avoid damaging the unit or your floor (use opened out unit carton).



- We do not recommend the use of power drill/drivers **for inserting screws**, as this could damage the unit. Only use hand screwdrivers.

- **Safety note:** It is recommended that this unit is secured to a wall using the overbalance kit supplied.

- Dispose of all packaging carefully and responsibly.

Care and maintenance

- Only clean using a damp cloth and mild detergent, do not use bleach or abrasive cleaners.

- From time to time check that there are no loose screws on this unit.

- This product should not be discarded with household waste. Take to your local authority waste disposal centre.

Note: If required the next page can be cut out and used as reference throughout the assembly. Keep this page with these instructions for future reference.

Components - Panels

If you have damaged or missing components, call the **Customer Helpline: 08456 400800** quoting the reference numbers below

Please check you have all the panels listed below

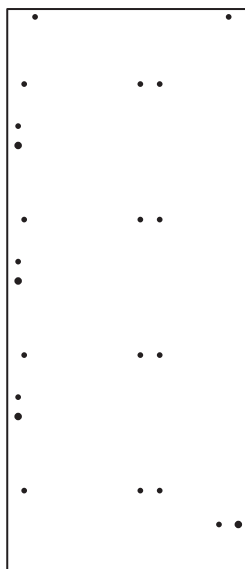

1 Left Side (DF2098A)
(930 x 396mm)

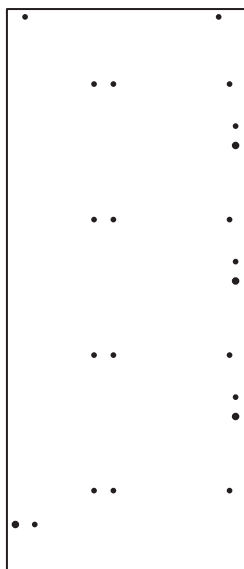

2 Right Side (DF2099A)
(930 x 396mm)



3 Top (D1567A)
(718 x 395mm)



4 Rail (D1570A)
(718 x 60mm) x 4

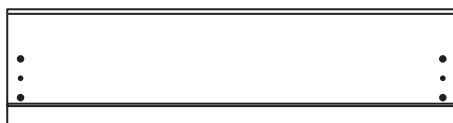

5 Drawer Front (DF2092A)
(742 x 192mm) x 4



6 Left Drawer Side (W370-124LH)
(370 x 124mm) x 4



7 Right Drawer Side (W370-124RH)
(370 x 124mm) x 4



8 Drawer Back (W686-124)
(686 x 124mm) x 4



9 Drawer Base (T697-367)
(697 x 367mm) x 4

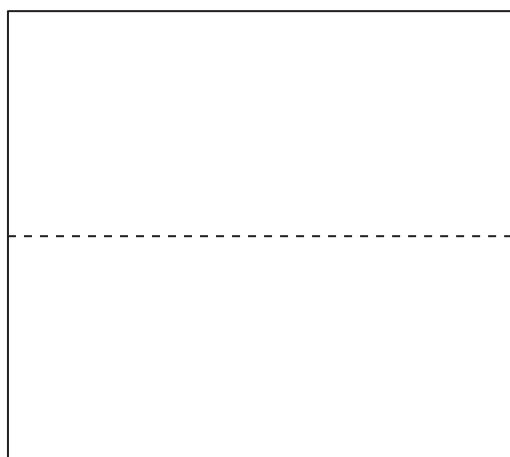

10 Back (X848-744)
(848 x 744mm)











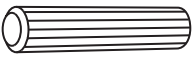
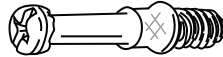

Components - Fittings

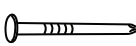
If you have damaged or missing components, call the **Customer Helpline: 08456 400800** quoting the reference numbers below

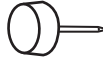
Please check you have all the fittings listed below

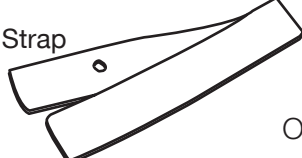
Note: The quantities below are the correct amount to complete the assembly. In some cases more fittings may be supplied than are required.

<p>A </p> <p>Wooden dowel (F22) x 8</p>	<p>B </p> <p>Metal dowel (F901) x 20</p>	<p>C </p> <p>Small locking nut (F3) x 8</p>	
<p>D </p> <p>Large locking nut (F900) x 12</p>	<p>E </p> <p>9mm Screw (F74) x 8</p>	<p>F </p> <p>9mm Screw (F73) x 16</p>	
<p>G </p> <p>Nail (F51) x 20</p>	<p>H </p> <p>Knock-in Peg (F171GY) x 16</p>	<p>I </p> <p>Plastic Nail (F91) x 4</p>	
<p>J </p> <p>Drawer runner (F1004) x 8</p>		<p>K </p> <p>Wedgefix (F639) x 16</p>	
<p>L   Screw  Washer x 2</p> <p>Overbalance protector kit (F269) x 1</p>			

Tools required

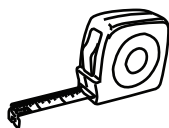

Rule



Cross-head screwdriver



Scissors



Hammer



Eye protection (when using a hammer or drill)



Electric drill (do not use for fitting screws)

Ruler - Use this ruler to help correctly identify the screws

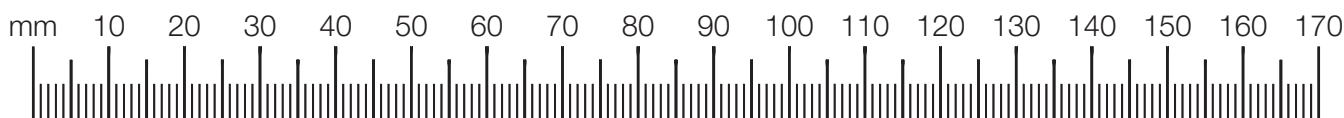

Assembly Instructions

If you have damaged or missing components, call the
Customer Helpline: 08456 400800 quoting the reference
numbers below

Step 1

Prepare the 4 drawer fronts

Screw 2 metal dowels **B** into each of the drawer fronts **5**.

Note: Tighten the metal dowels up fully against the panels.

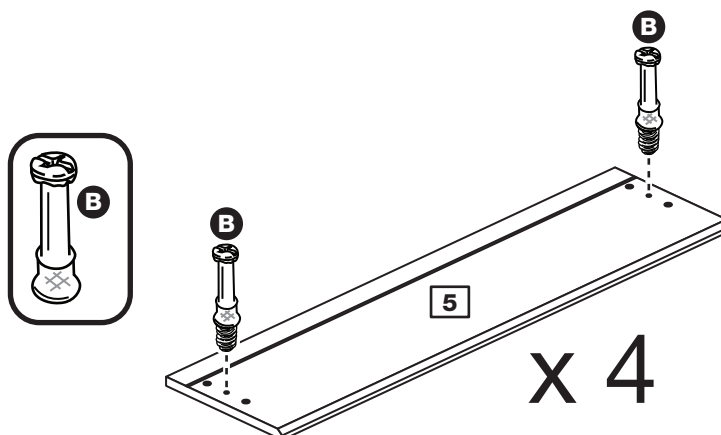

Step 2

Prepare the drawer sides

Insert a small locking nut **C** into the hole shown on the left drawer side **6** and the right drawer side **7**.

Note: The arrow on the locking nut **must** point towards the hole in the edge of the panel.

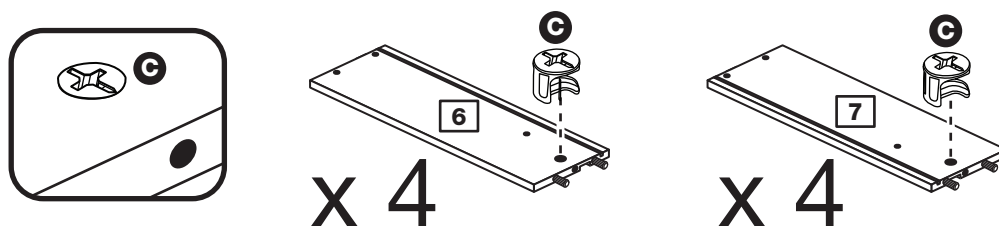

Step 3

Attach the drawer sides to the drawer front

Push the left drawer sides **6** and right drawer sides **7** onto the back of the drawer front **5**.

Turn the small locking nuts **C** on the left drawer side **6** and right drawer side **7**.

Note: Turn the locking nuts **C** clockwise to secure panels - more than 1/2 a turn.

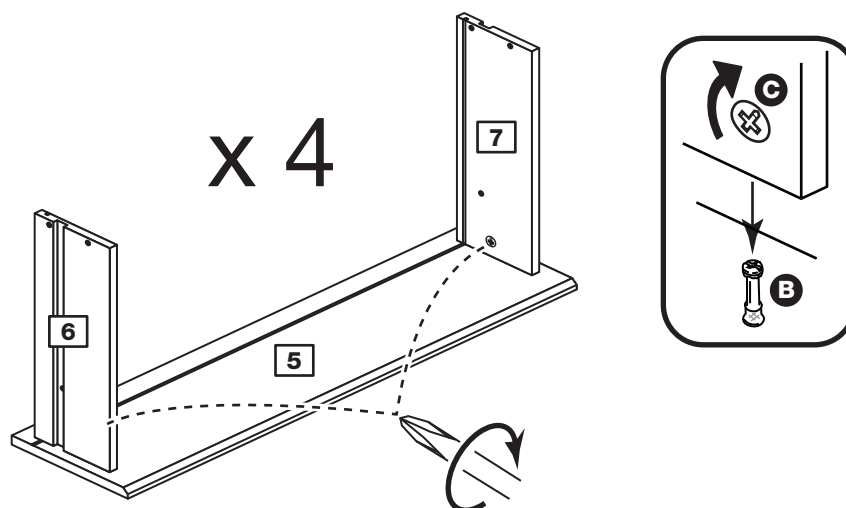

Assembly Instructions

Step 4

Fit the drawer base

Slide the drawer base **9** down the grooves in the drawer sides **6** and **7** and down into the groove in the drawer front **5**.

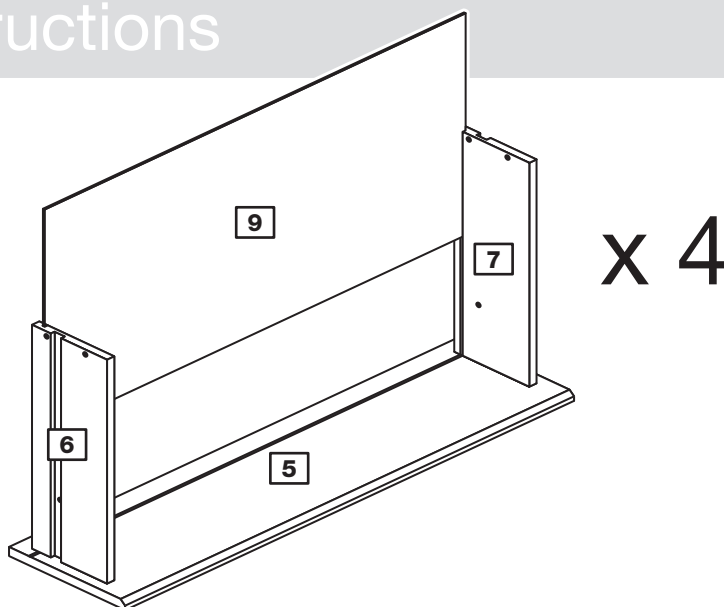

Step 5

Fit the drawer back

Fit the drawer back **8** between the drawer sides **6** and **7**. Make sure that the drawer base **9** fits into the groove in the drawer back **8**.

Hold the drawer back **8** in position and tap the knock-in pegs **H** through the holes in the drawer sides **6** and **7**.

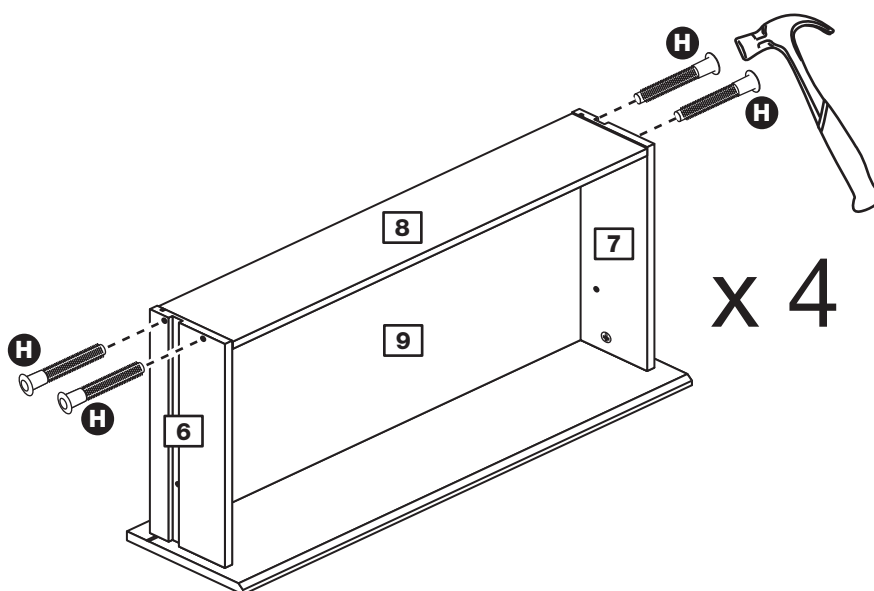

Step 6

Fit the wedgexes

Turn the drawer assemblies over and slide 4 wedgexes **K** into the front and back grooves, as shown, and tighten up the screws.

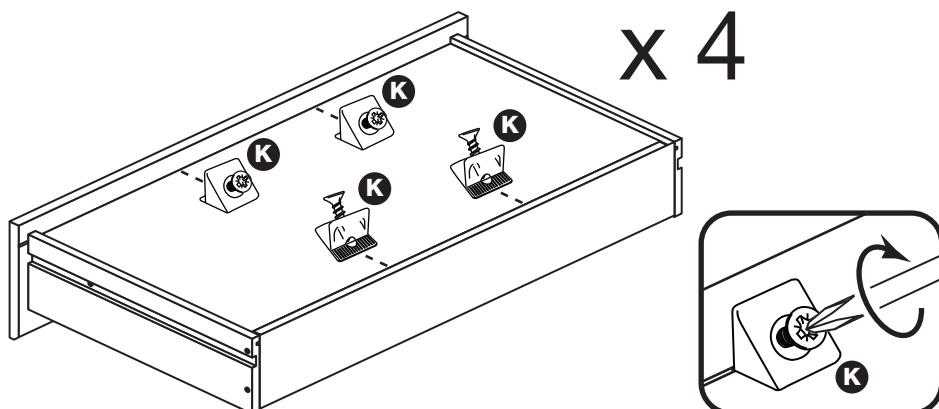

Assembly Instructions

Step 7

Prepare the left side

a: Place 4 runners **J** on the left side **1** as shown. Slide back the top of runner and use the 2nd hole from the front to fit the 1st screw **F**.

b: Slide the runner **J** back the other way and fit the 2nd screw **F** into the corresponding hole in the left side **1**.

Screw 6 metal dowels **B** into the left side **1**.

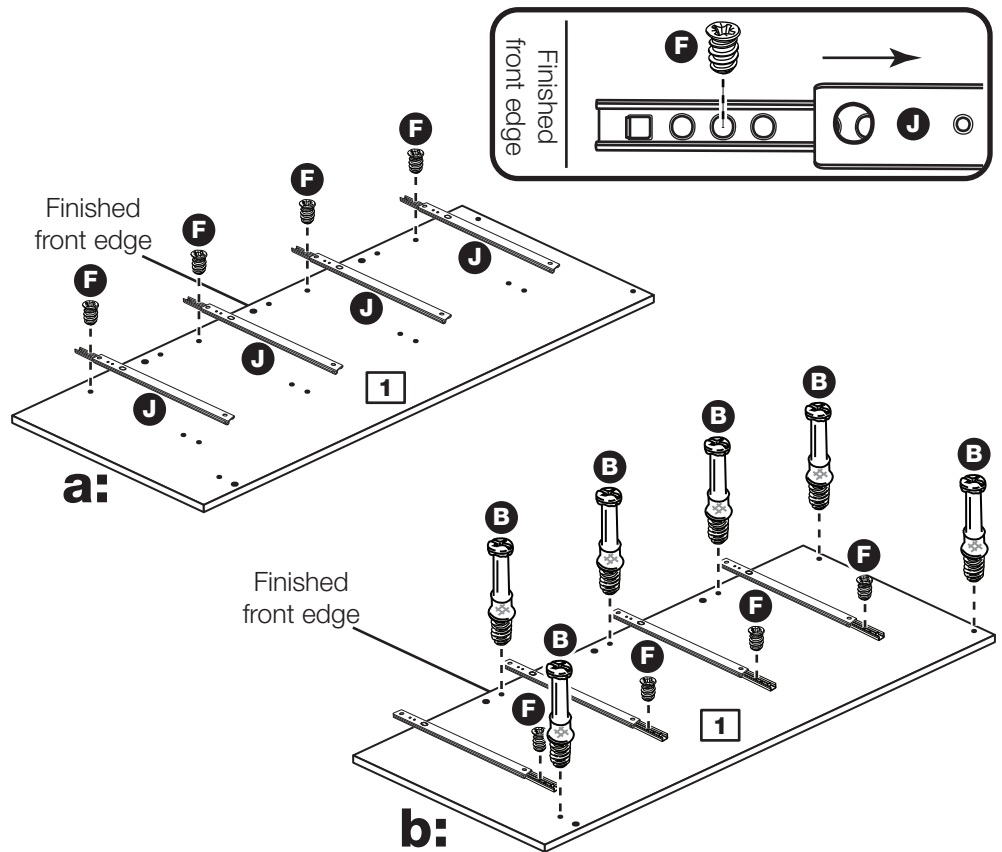

Step 8

Prepare the right side

a: Place 4 runners **J** on the right side **2** as shown. Slide back the top of runner and use the 2nd hole from the front to fit the 1st screw **F**.

b: Slide the runner **J** back the other way and fit the 2nd screw **F** into the corresponding hole in the right side **2**.

Screw 6 metal dowels **B** into the right side **2**.

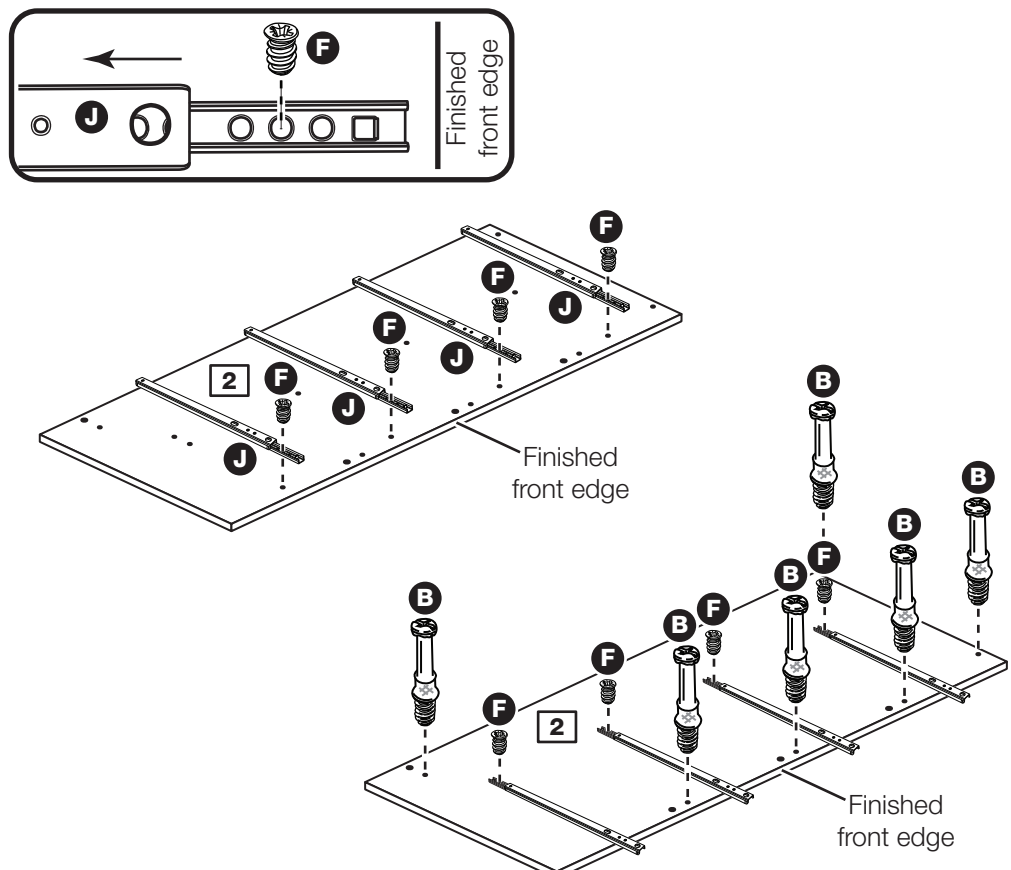

Assembly Instructions

Step 9

Prepare the top

Insert 4 large locking nuts **D** into the top **3**.

Note: The arrow on the locking nut **must** point towards the hole in the edge of the panel.

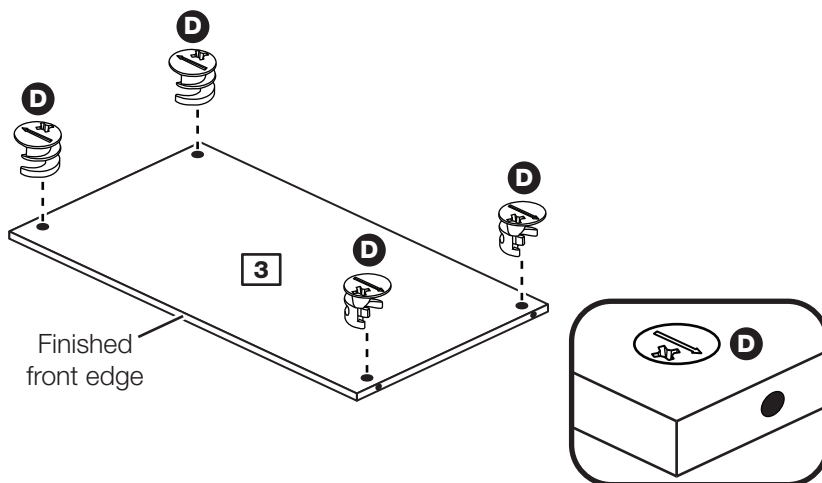

Step 10

Fit the top to the right side

Push the top **3** onto the right side **2**.

Use a screwdriver to tighten the 2 large locking nuts **D** fitted to the top **3**.

Note: Turn the large locking nuts **D** as far as they will go - more than 1/2 a turn.

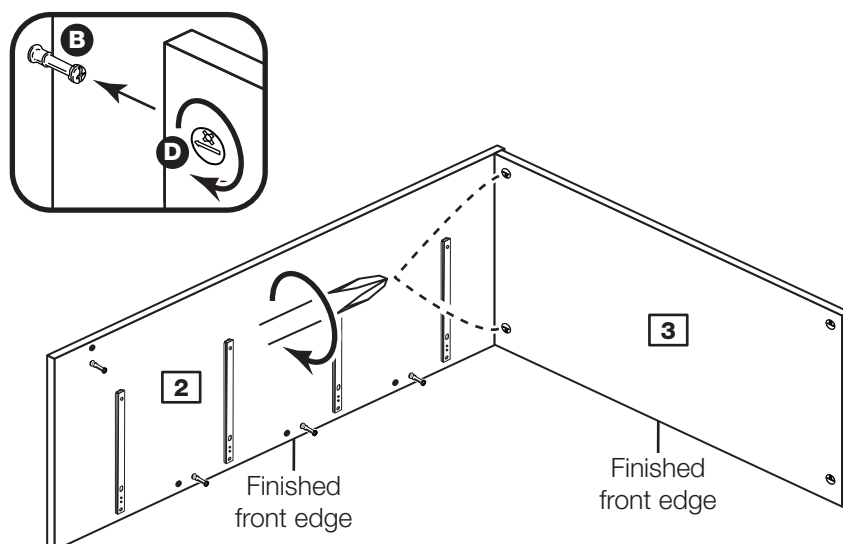

Step 11

Prepare the 4 rails

Insert 2 large locking nuts **D** into each of the 4 rails **4**.

Tap 2 wooden dowels **A** into each of the 4 rails **4**.

Note: Wooden dowels **must not** stick out from the edge by more than 10mm or they may damage other panels.

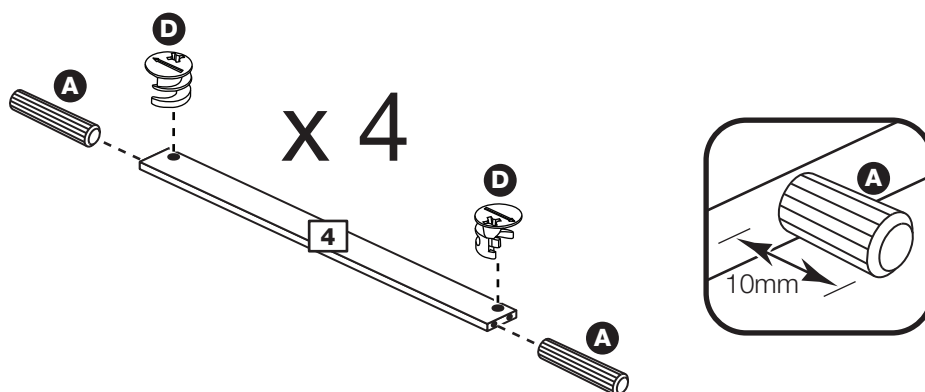

Assembly Instructions

Step 12

Fit 3 of the rails

Push 3 rails **4** onto the right side **2**.

Use a screwdriver to tighten the 3 large locking nuts **D** fitted to the 3 rails **4**.

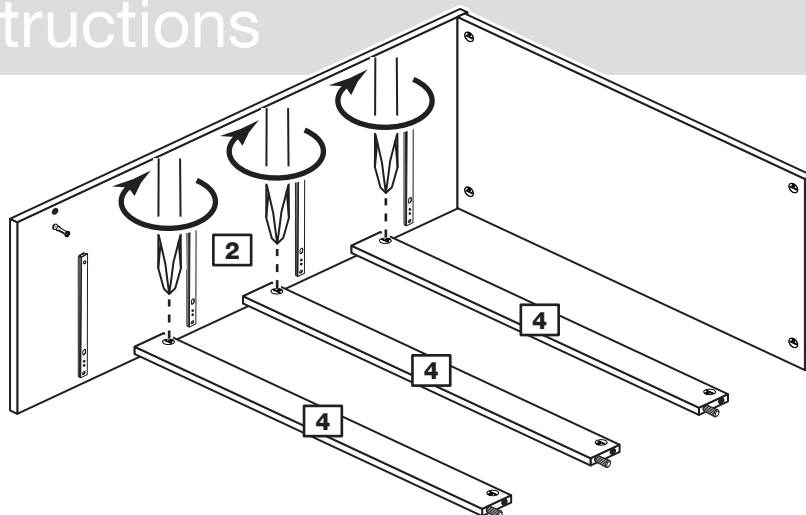

Step 13

Fit the last rail

Push the last rail **4** onto the right side **2**.

Use a screwdriver to tighten the large locking nut **D** fitted to the last rail **4**.

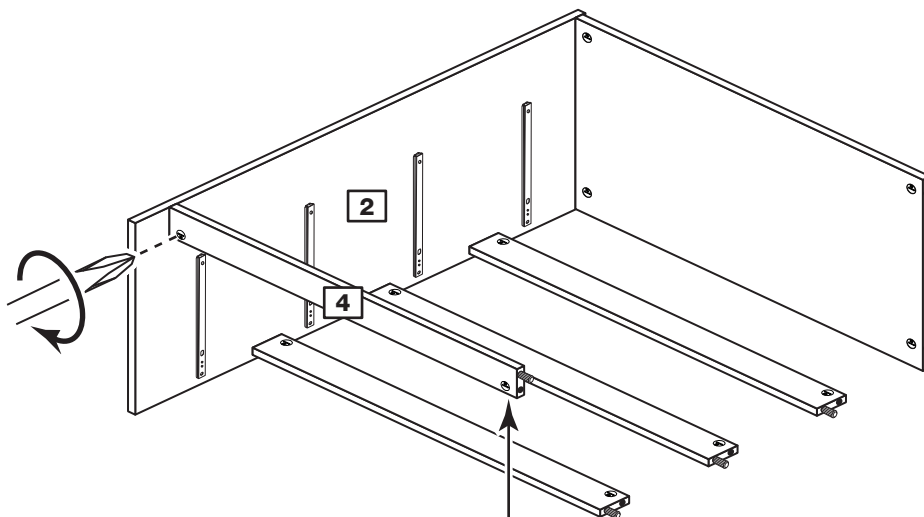

Note: Support this rail until the left side has been fitted in the next step.

Step 14

Fit the left side

Push the left side **1** onto the assembly.

Use a screwdriver to tighten the 6 large locking nuts **D** fitted to the top **3** and rails **4**.

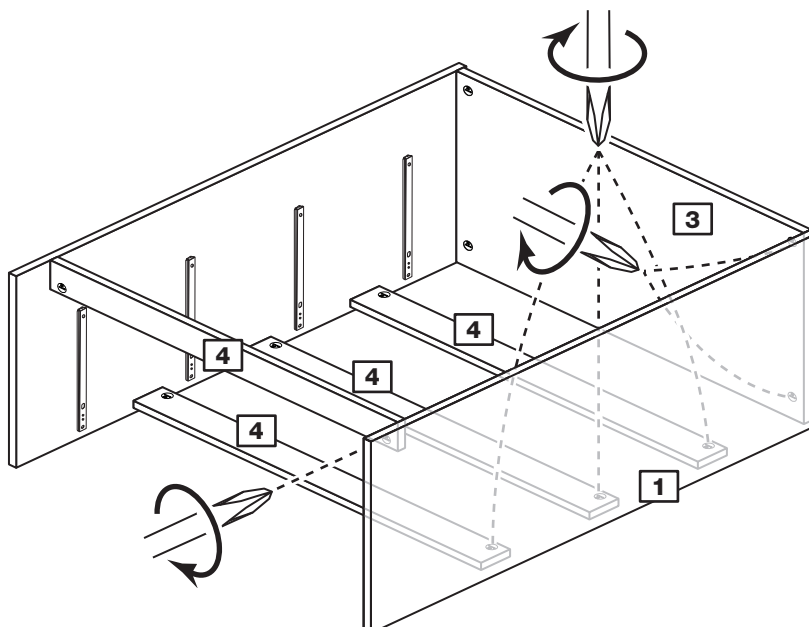

Assembly Instructions

Step 15

Fit the back

a: Square up the unit by making sure that measurement **x** to **x** equals **y** to **y**.

b: Place the back **10** onto the unit.

Nail **G** around the outside edges of the back **10**.

Note: Nails should be evenly spaced out.

a: The measurement from top corner X to bottom corner X must be equal to the measurement from top corner Y to bottom corner Y

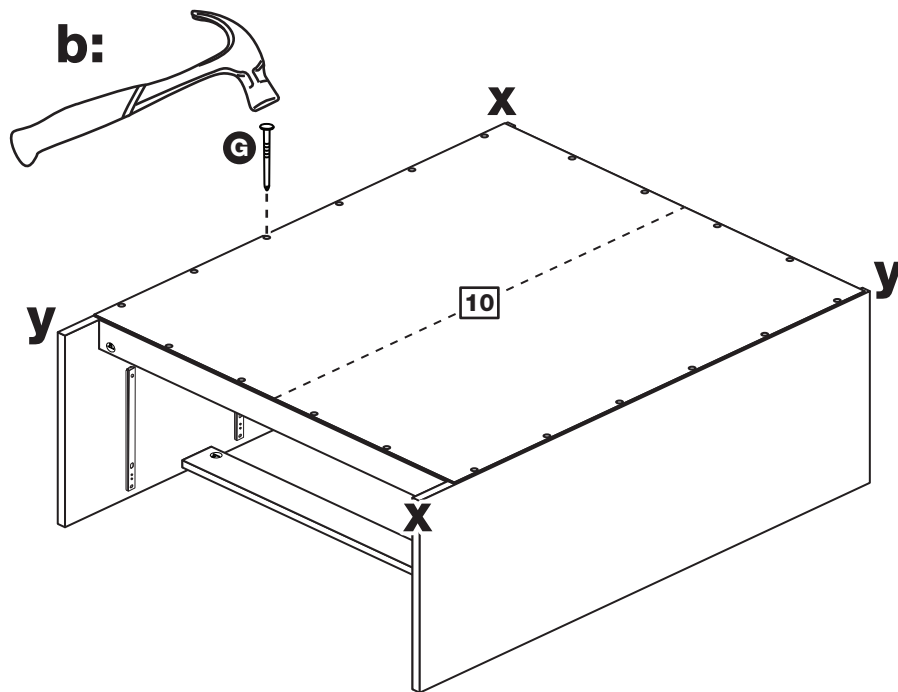

Step 16

Fit the 4 plastic nails

Tap 2 plastic nails **1** into the bottom edge of each of the sides **1** and **2**.

Stand the unit up for the next step.

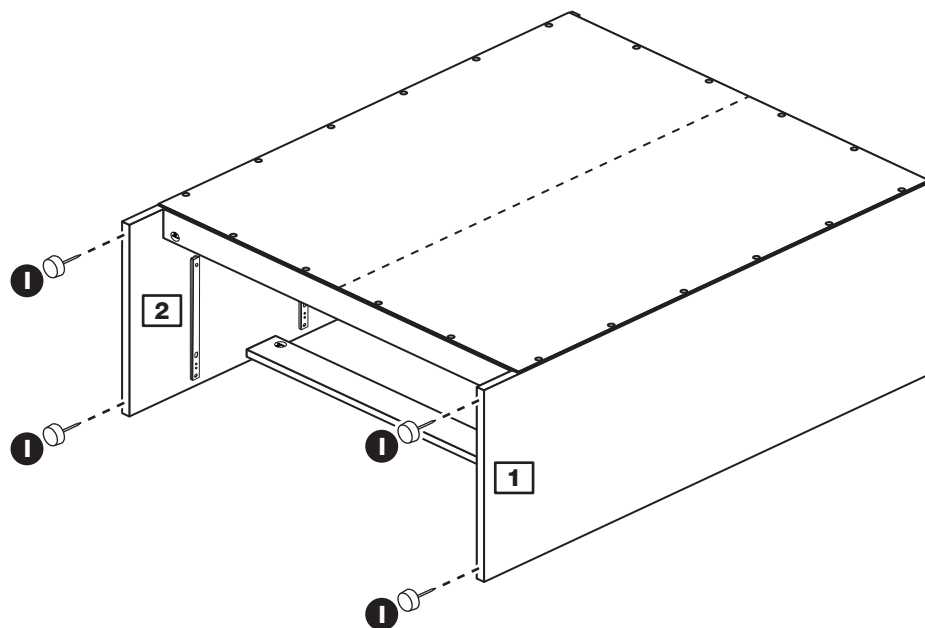

Assembly Instructions

Step 17

Fit the drawers

Starting with the bottom drawer, slide both the runners **J** forward and locate the drawer sides **6** and **7** between them, lining up the holes in the drawer wrap with the 2nd 'threaded' holes in the runners **J**.

Working from the inside of the drawer, insert 2 screws **E** through the drawer sides and out into the 2nd threaded hole in the runner.

Note: Do not overtighten the screws **E**.

If they catch on the runner you may need to loosen them slightly.

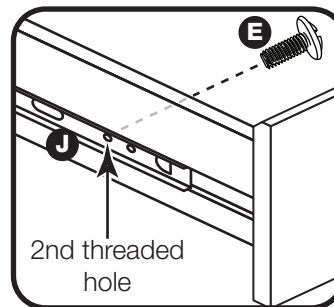
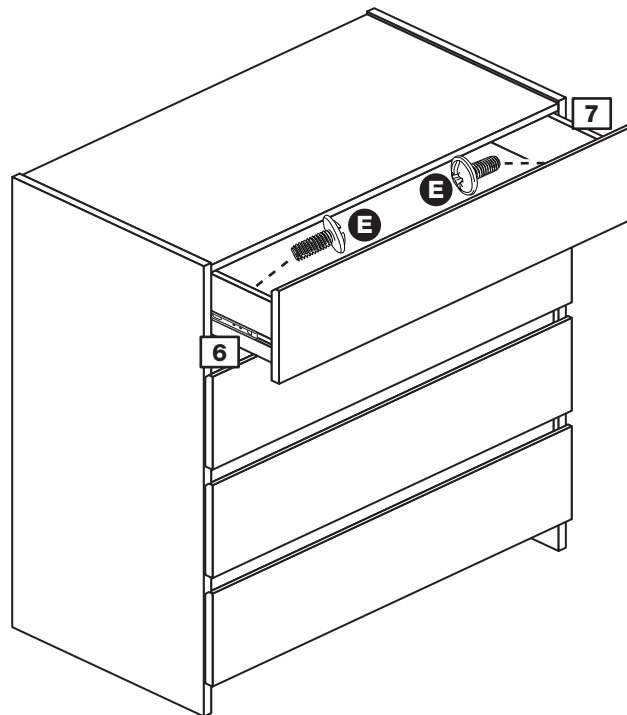

Assembly Instructions

Step 14

Fit the overbalance protector

To prevent possible overbalancing we recommend that this unit is secured to a suitable wall by use of the overbalance protector kit **L** fitted to the unit or, an alternative fixing method of your choice.

Wall fixings are not supplied as they will need to suit the wall type.

Note: Take care when drilling the wall that you do not drill into any pipes, wires etc. If in doubt, consult an expert.

Assembly is complete

Example

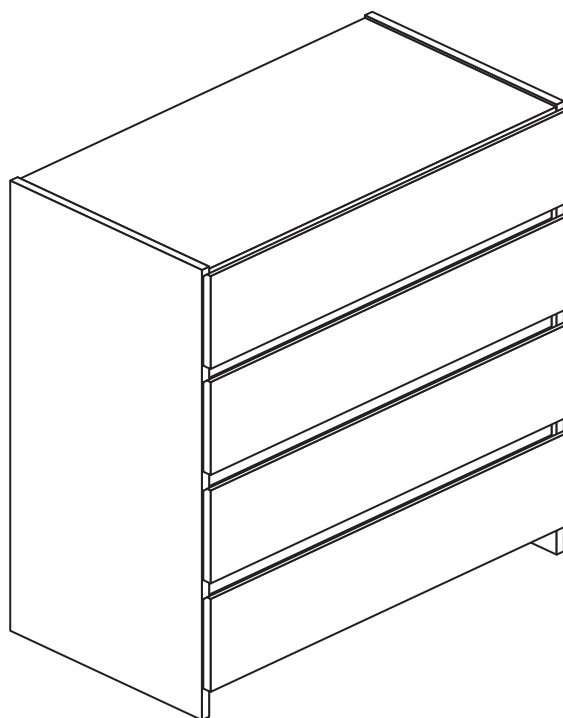
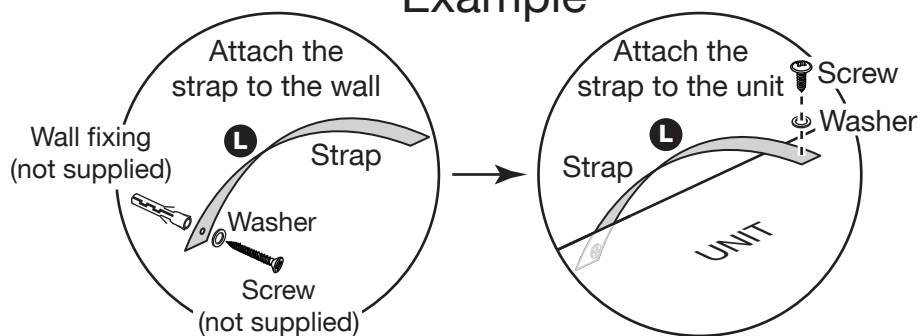

If you need help or have damaged or missing parts, call the Customer Helpline: 08456 400800 and quote the reference numbers on the component pages.

Argos Ltd, 489-499 Avebury Boulevard, Central Milton Keynes, MK9 2NW

Denver - 3 Door Mirror Robe

Assembly Instructions - Please keep for future reference

360/2546

335/9806

359/7596

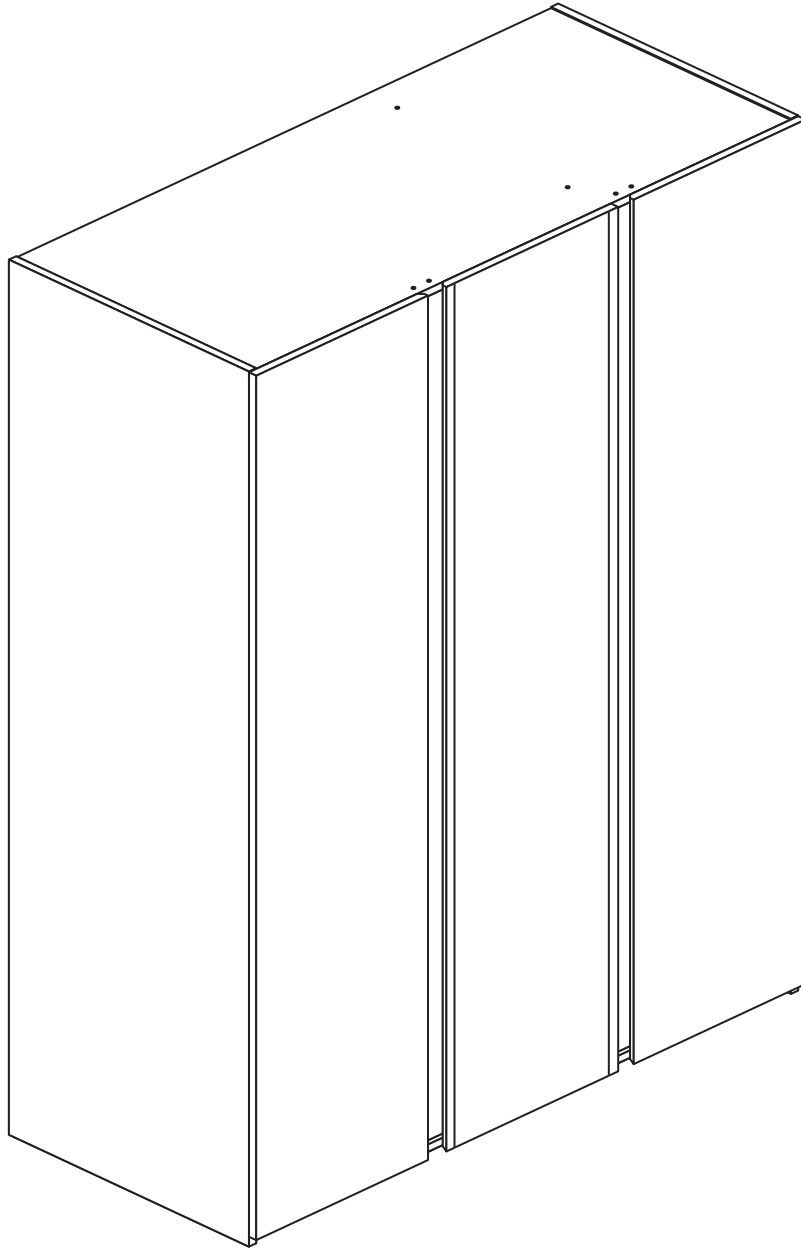

Dimensions

Width - 113.5cm

Depth - 50cm

Height - 181cm



**MADE IN
BRITAIN**

Important - Please read these instructions fully before starting assembly

If you need help or have damaged or missing parts, call the **Customer Helpline: 03456 400800**



Safety and Care Advice

Important - Please read these instructions fully before starting assembly

- **Warning:** This unit weighs approximately 80kgs. Please lift with care.
- Check you have all the components and tools listed on pages 2 and 3.
- Remove all fittings from the plastic bags and separate them into their groups.
- Keep children and animals away from the work area, small parts could choke if swallowed.
- Parts of the assembly will be easier with 2 people.

- Make sure you have enough space to layout the parts before starting.
- Do not stand or put weight on the product, this could cause damage.
- Assemble the item as close to its final position (in the same room) as possible.
- Assemble on a soft level surface to avoid damaging the unit or your floor (use opened out unit carton).









• We do not recommend the use of power drill/drivers **for inserting screws**, as this could damage the unit. Only use hand screwdrivers.

- **Safety note:** It is recommended that this unit is secured to a wall using the overbalance protector kit supplied or, an alternative fixing method of your choice.
- Dispose of all packaging carefully and responsibly.

Care and maintenance

- Only clean using a damp cloth and mild detergent, do not use bleach or abrasive cleaners.
- From time to time check that there are no loose screws on this unit.
- This product should not be discarded with household waste. Take to your local authority waste disposal centre.

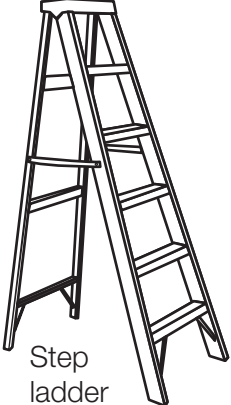
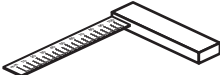
Tools required

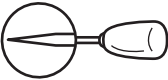
 Rule	 Spirit level	 Eye protection (when using a hammer or drill)	 Cross-head screwdriver	 Electric drill (only use when drilling into walls)	 Step ladder
 Square	 Scissors	 Hammer	 Bradawl		

Note: If required the next page can be cut out and used as reference throughout the assembly. Keep this page with these instructions for future reference.

Components - Panels

If you have damaged or missing components, call the **Customer Helpline: 03456 400800** quoting the reference numbers below

Please check you have all the panels listed below



1 Left Side (D1575A)
(1808 x 496mm)

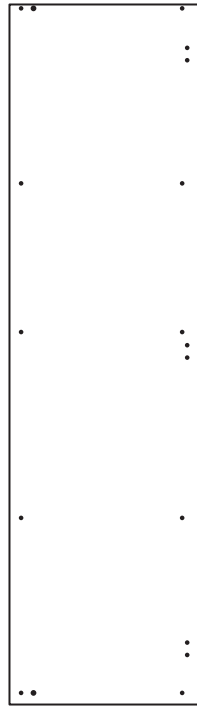

2 Right Side (DF1987)
(1808 x 496mm)

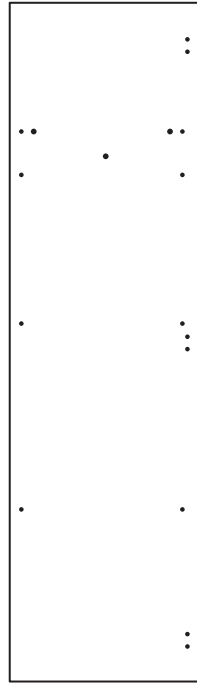

3 Divider (DF2668)
(1753 x 494mm)



4 Top/Base (DF1877A)
(1105 x 494mm) x 2

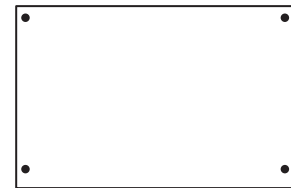

5 Horizontal (DF3100A)
(718 x 470mm)



6 Shelf (DF2353)
(372 x 470mm) x 3



7 Hanging Rail (FHR710)
(710mm long)

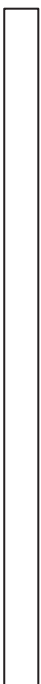

8 Vertical Rail (D1577A)
(1752 x 88mm)
x 2

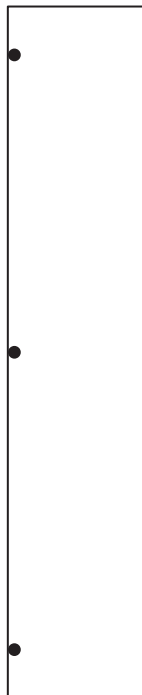

9 Door (D1578A)
(1786 x 355mm)
x 2

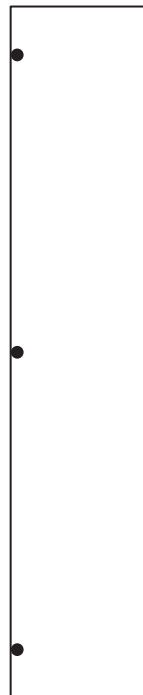

10 Mirror Door (D1578MA)
(1786 x 355mm)
(Mirror - SG06
1776 x 300mm
Safety Back SAR)

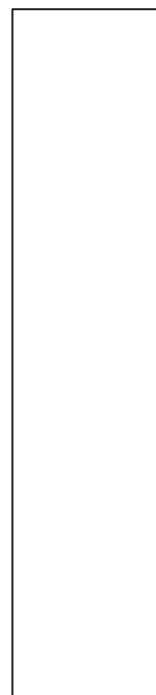

11 Small Back (X1779-391)
(1779 x 391mm)

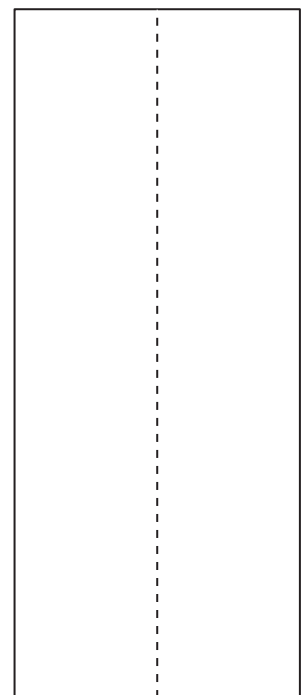

12 Large Back (X1779-737)
(1779 x 737mm)











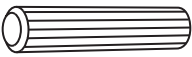
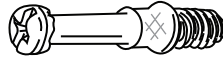
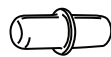

Components - Fittings

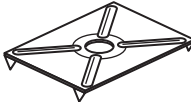
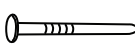
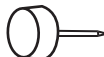
If you have damaged or missing components, call the **Customer Helpline: 03456 400800** quoting the reference numbers below

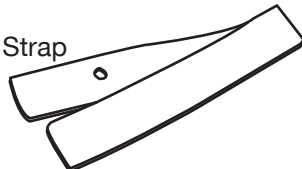
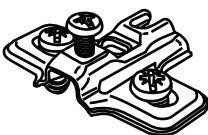
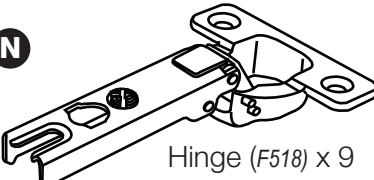
Please check you have all the fittings listed below

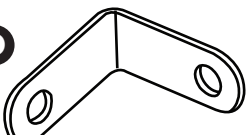
Note: The quantities below are the correct amount to complete the assembly. In some cases more fittings may be supplied than are required.

<p>A </p> <p>Wooden dowel (F22) x 6</p>	<p>B </p> <p>Metal dowel (F901) x 12</p>	<p>C </p> <p>Shelf stud (F110) x 12</p>
<p>D </p> <p>Large locking nut (F900) x 12</p>	<p>E </p> <p>40mm Screw (F910) x 12</p>	<p>F </p> <p>13mm Screw (F63) x 20</p>
<p>G </p> <p>Nail screw (F277) x 6</p>	<p>H </p> <p>Back holder (F276) x 6</p>	<p>I </p> <p>Nail (F51) x 38</p>
<p>J </p> <p>Plastic Nail (F91) x 4</p>	<p>K </p> <p>Rail holder (F1014) x 2</p>	<p>L </p> <p>Strap</p>
<p>M </p> <p>Hinge plate (F523) x 9</p>	<p>N </p> <p>Hinge (F518) x 9</p>	<p> Screw  Washer x 2</p> <p>Overbalance protector kit (F269) x 1</p>
<p>O </p> <p>Bracket (F945) x 2</p>	<p>P </p> <p>13mm Screw (F79) x 4</p>	

Important: Always pair up the hinges with the hinge plates from the same bag. DO NOT mix them up.

Ruler - Use this ruler to help correctly identify the screws

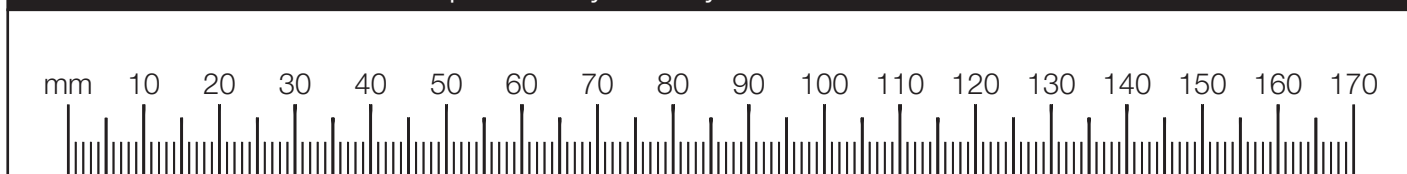

Assembly Instructions

If you have damaged or missing components, call the Customer Helpline: 03456 400800 quoting the reference numbers below

Step 1

Prepare the left side

Screw 6 metal dowels **B** into the left side **1**.

Push a rail holder **K** into the left side **1**. Make sure that it is fitted straight, in line with the panel edges and then secure with screw **F**.

Fit 3 hinge plates **M** onto the left side **1**, making sure that the slot is facing towards the finished front edge.

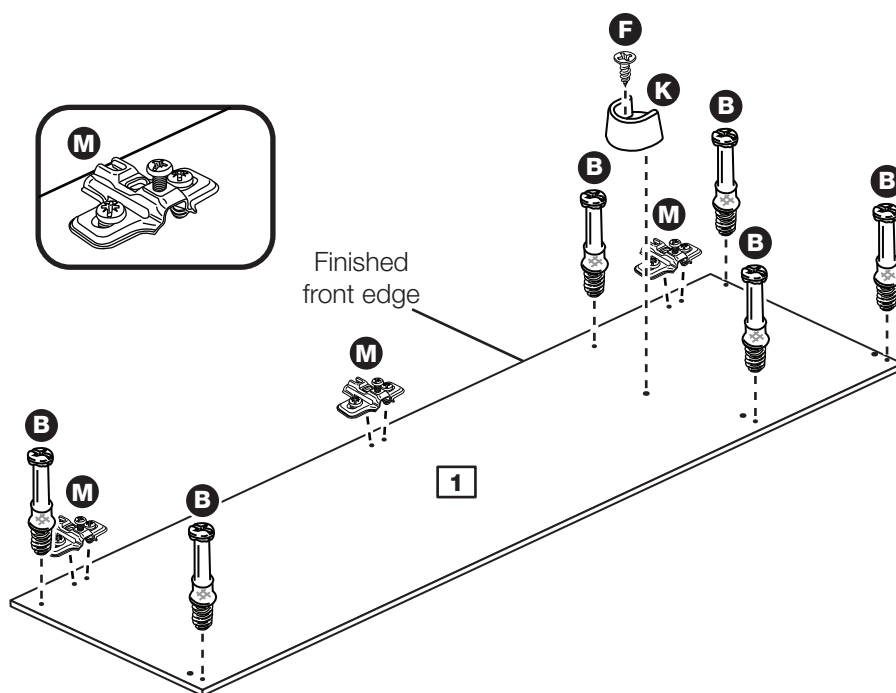

Step 2

Prepare the right side

Screw 4 metal dowels **B** into the right side **2**.

Fit 3 hinge plates **M** onto the right side **2**, making sure that the slot is facing towards the finished front edge.

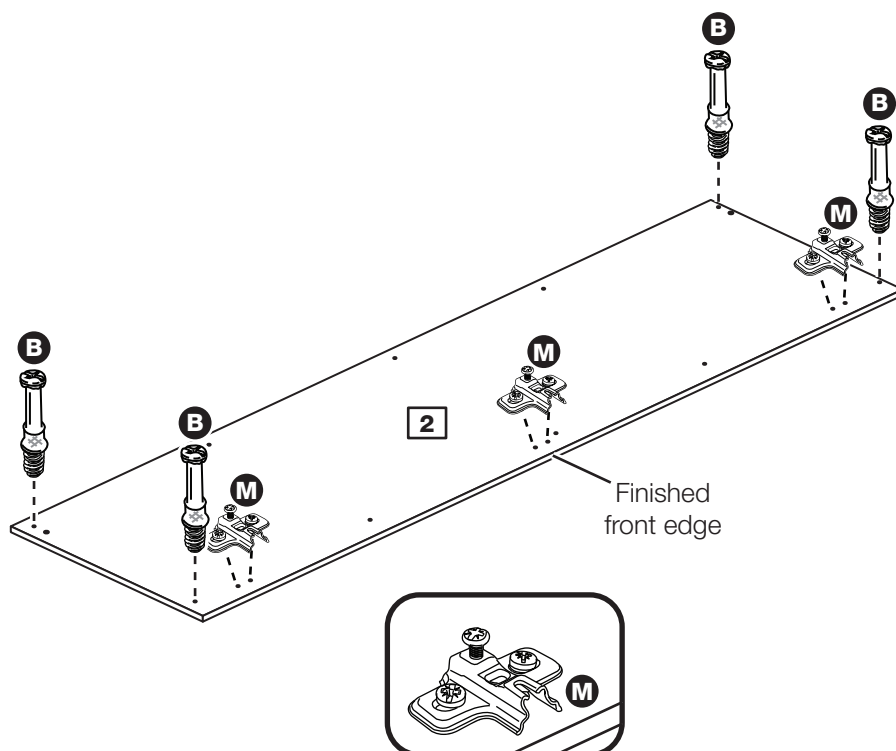

Assembly Instructions

Step 3

Prepare the 2 top and base panels

Tap 2 wooden dowels **A** into each of the top and base panels **4**.

Note: Wooden dowels **must not** stick out from the edge by more than 10mm or they may damage other panels.

Insert 4 large locking nuts **D** into each of the top and base panels **4**.

Note: The arrow on the locking nut **must** point towards the hole in the edge of the panel.

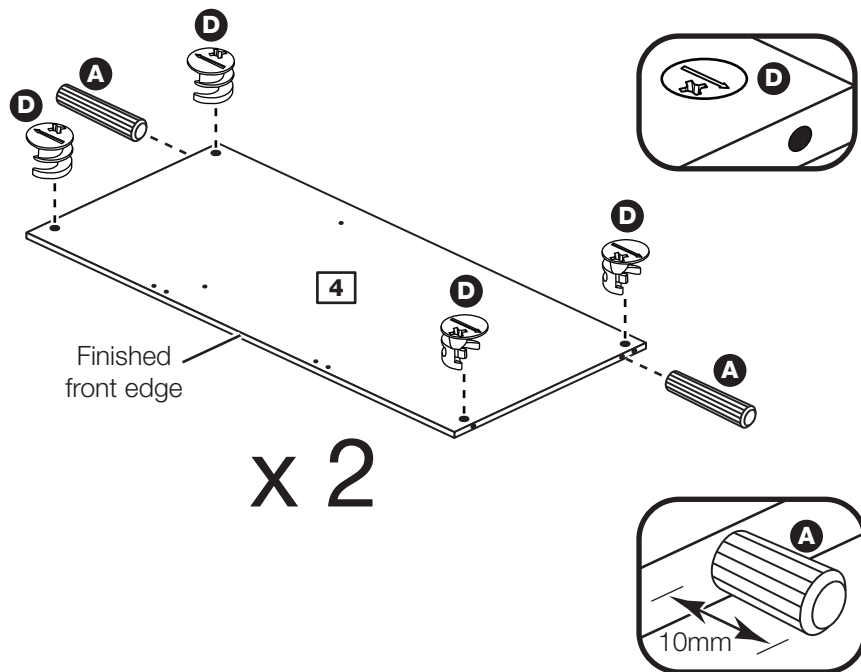

Step 4

Fit the top and base

Push the top **4** and base **4** onto the right side **2**.

Use a screwdriver to tighten the 2 large locking nuts **D** fitted to the top **4** and the 2 large locking nuts **D** fitted to the base **4**.

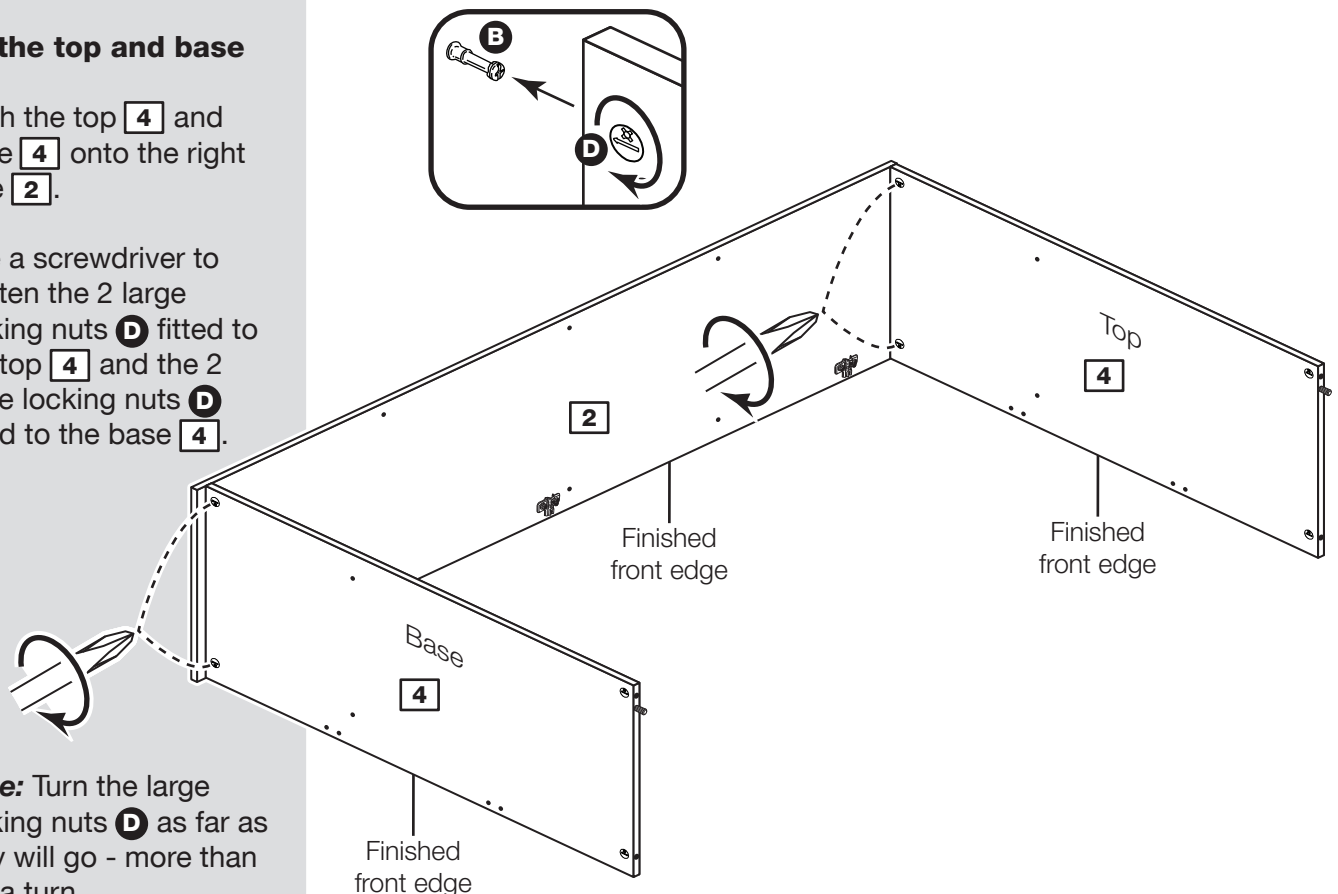

Note: Turn the large locking nuts **D** as far as they will go - more than 1/2 a turn.

Assembly Instructions

Step 5

Fit the 2 vertical rails

Attach each of the vertical rails **8** to the top **4** and base **4** using 4 screws **E**.

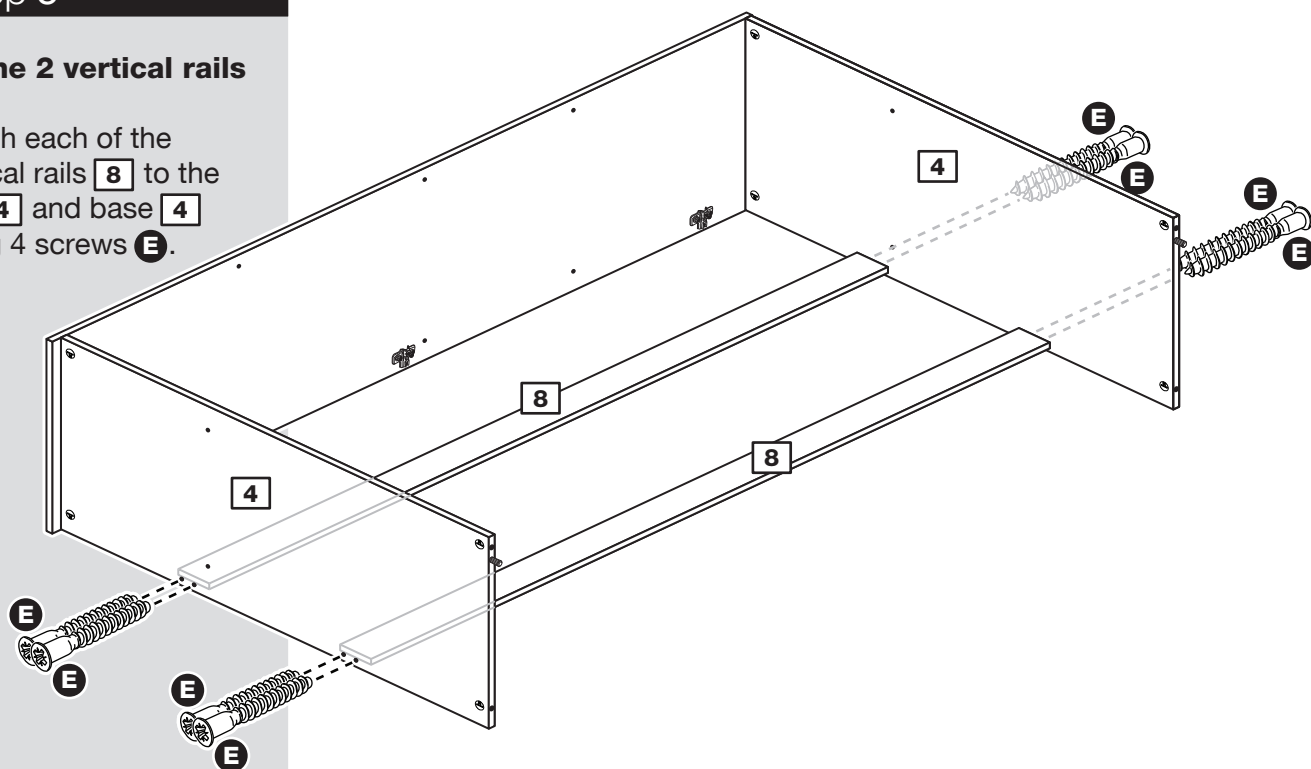

Step 6

Prepare the divider

Screw 2 metal dowels **B** into the divider **3**.

Push a rail holder **K** into the divider **3**. Make sure that it is fitted straight, in line with the panel edges and then secure with screw **F**.

Fit 3 hinge plates **M** onto the divider **3**, making sure that the slot is facing towards the finished front edge.

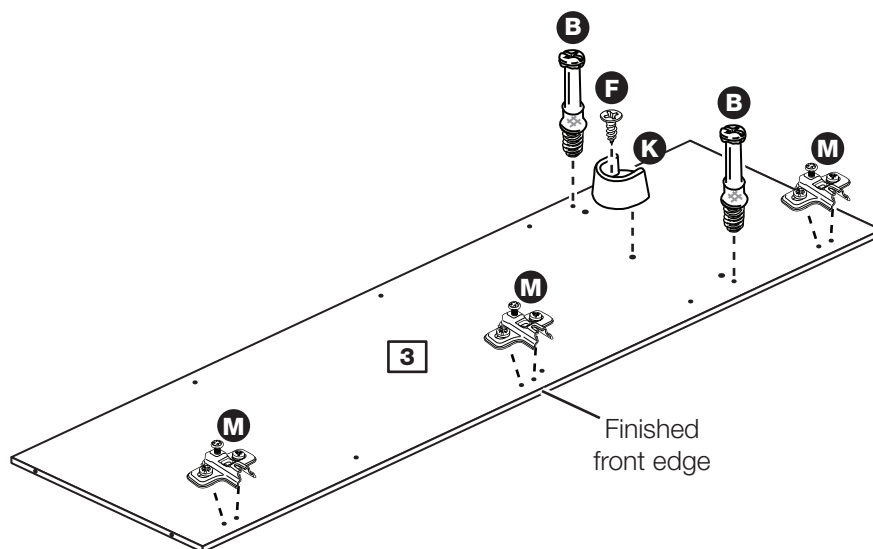

Assembly Instructions

Step 7

Fit the divider

Attach the divider **3** to the top **4** and base **4** using 4 screws **E**.

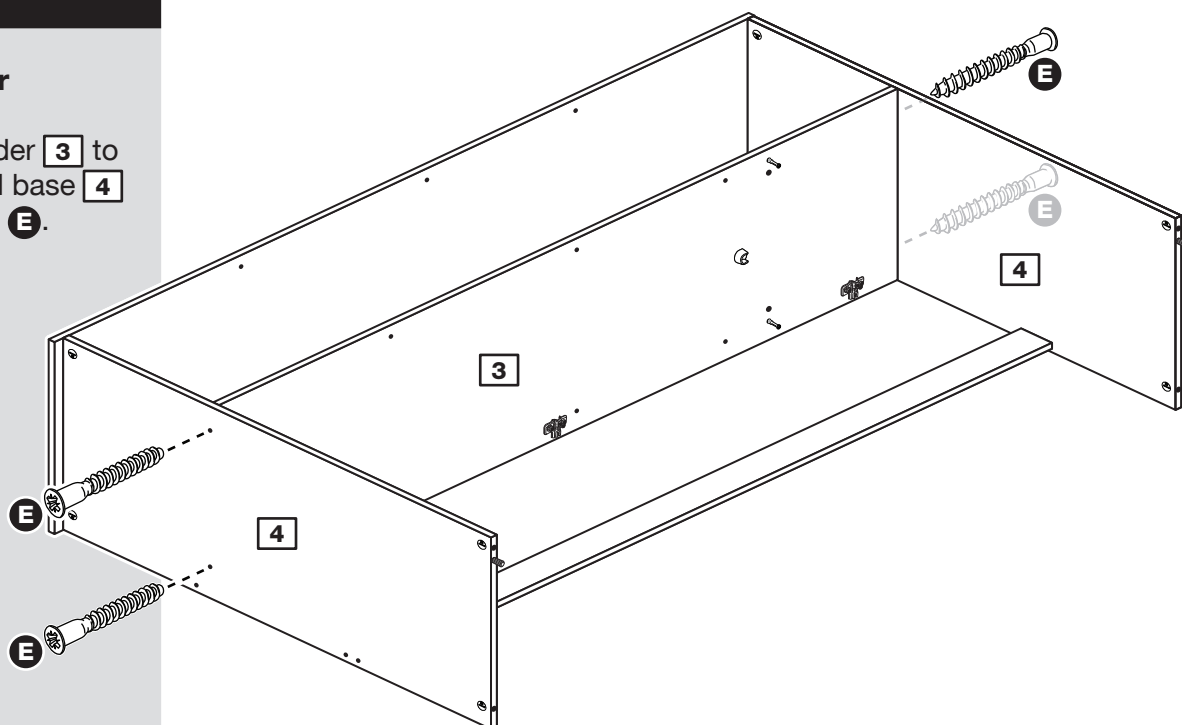

Step 8

Prepare the horizontal

Tap 2 wooden dowels **A** into the horizontal **5**.

Insert 4 large locking nuts **D** into the horizontal **5**.

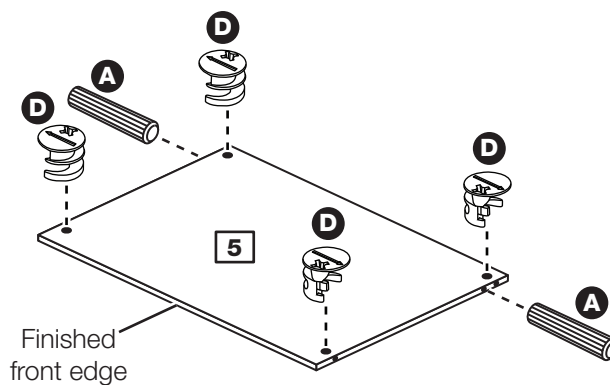

Assembly Instructions

Step 9

Fit the horizontal

Push the horizontal **5** onto the divider **3**.

Use a screwdriver to tighten the 2 large locking nuts **D** fitted to the horizontal **5**.

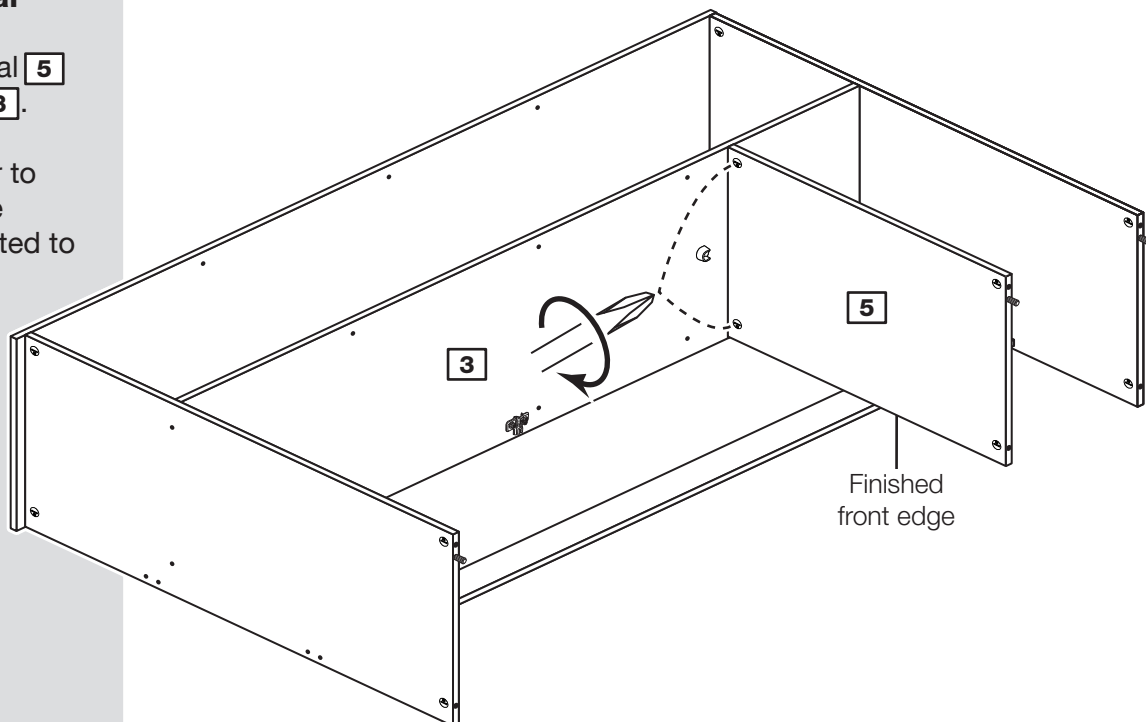

Step 10

Fit the left side

Push the left side **1** onto the assembly.

Use a screwdriver to tighten the 6 large locking nuts **D** fitted to the top **4**, base **4** and the horizontal **5**.

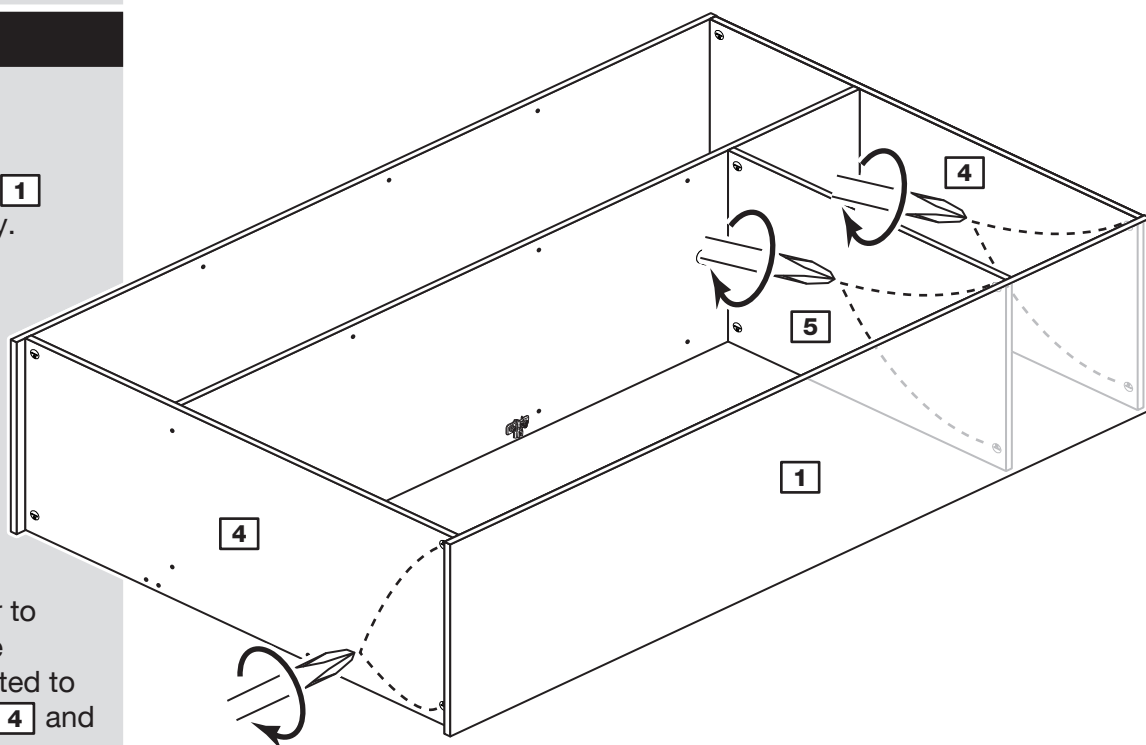

Assembly Instructions

Step 11

Fit the brackets

a: Fit a bracket **O** up against the divider **3** and rail **8** about 900mm from the top using 2 screws **P**.

a:

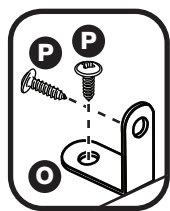

900mm

b:

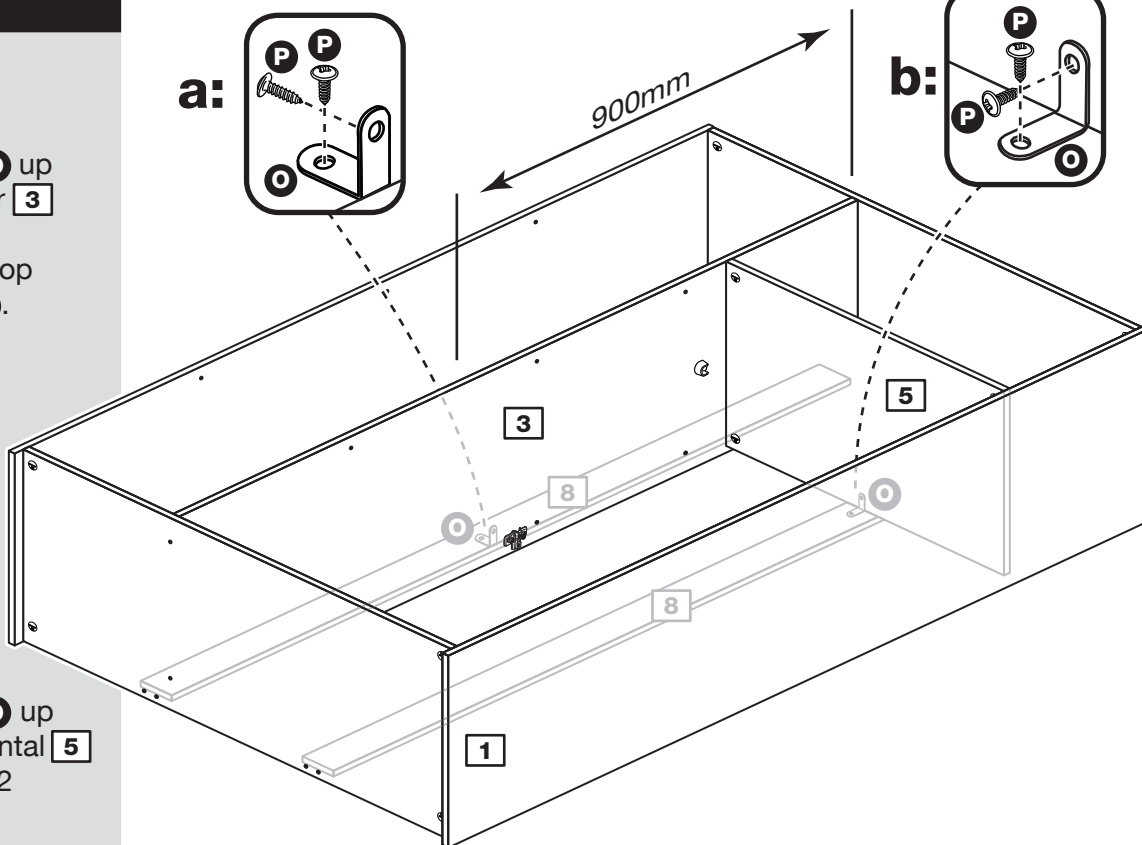
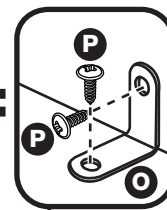

b: Fit a bracket **O** up against the horizontal **5** and rail **8** using 2 screws **P**.

Step 12

Fit the 4 plastic nails

Tap 2 plastic nails **J** into the bottom edge of each of the sides **1** and **2**.

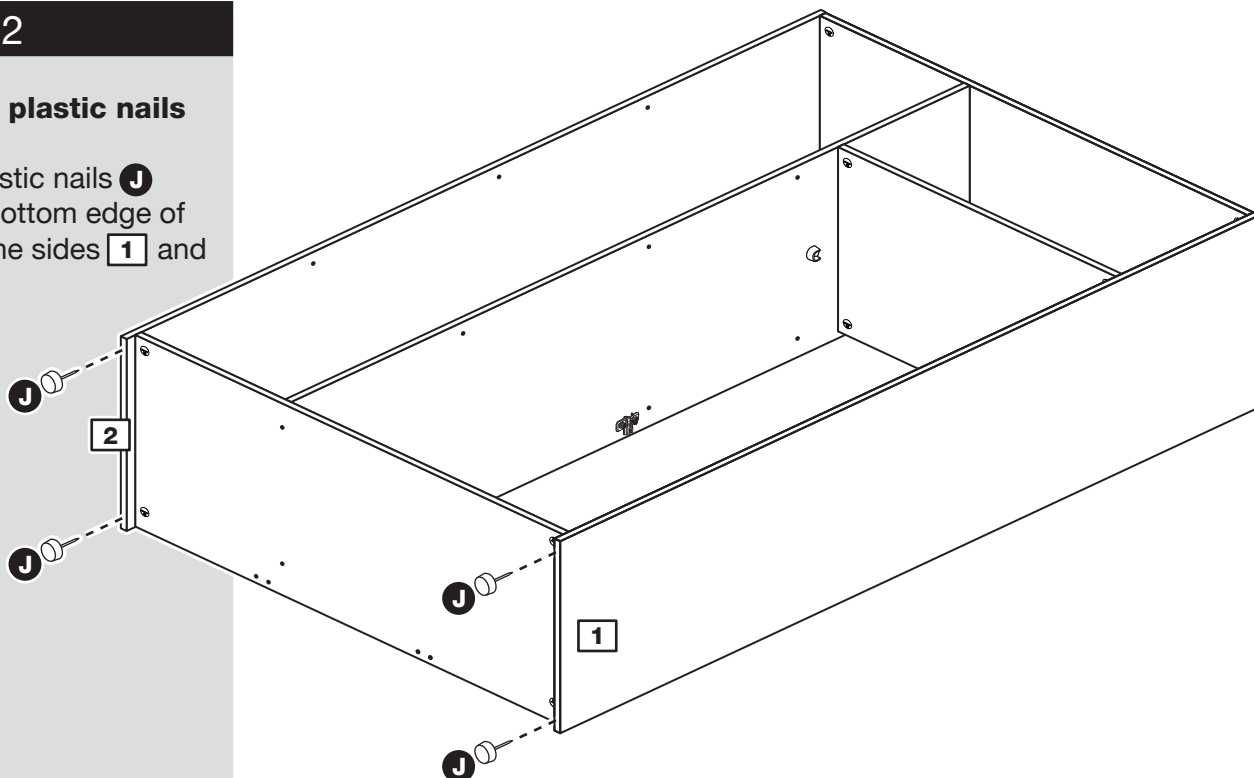

Assembly Instructions

Step 13

Fit the back panels

a: Square up the unit by making sure that measurement **x:x equals y:y**.

Place the small back **11** and large back **12** down, onto the unit as shown.

Make sure that the 2 backs are pushed up tight against each other and that they meet in the centre of the divider's back edge.

b: Nail **1** around the outside edges of the 2 backs.

Note: Do not nail where the 2 backs meet and nails should be spaced about 150mm apart.

c: Push the 5 nail screws **G** through the 5 back holders **H** and tap them down between the small back **11** and large back **12** and into the back edge of the divider **3**.

Keep tapping the nail screws **G** in until the back holders **H** dig into the small and large back.

Stand the unit up for the next step.

a: The measurement from top corner X to bottom corner X must be equal to the measurement from top corner Y to bottom corner Y

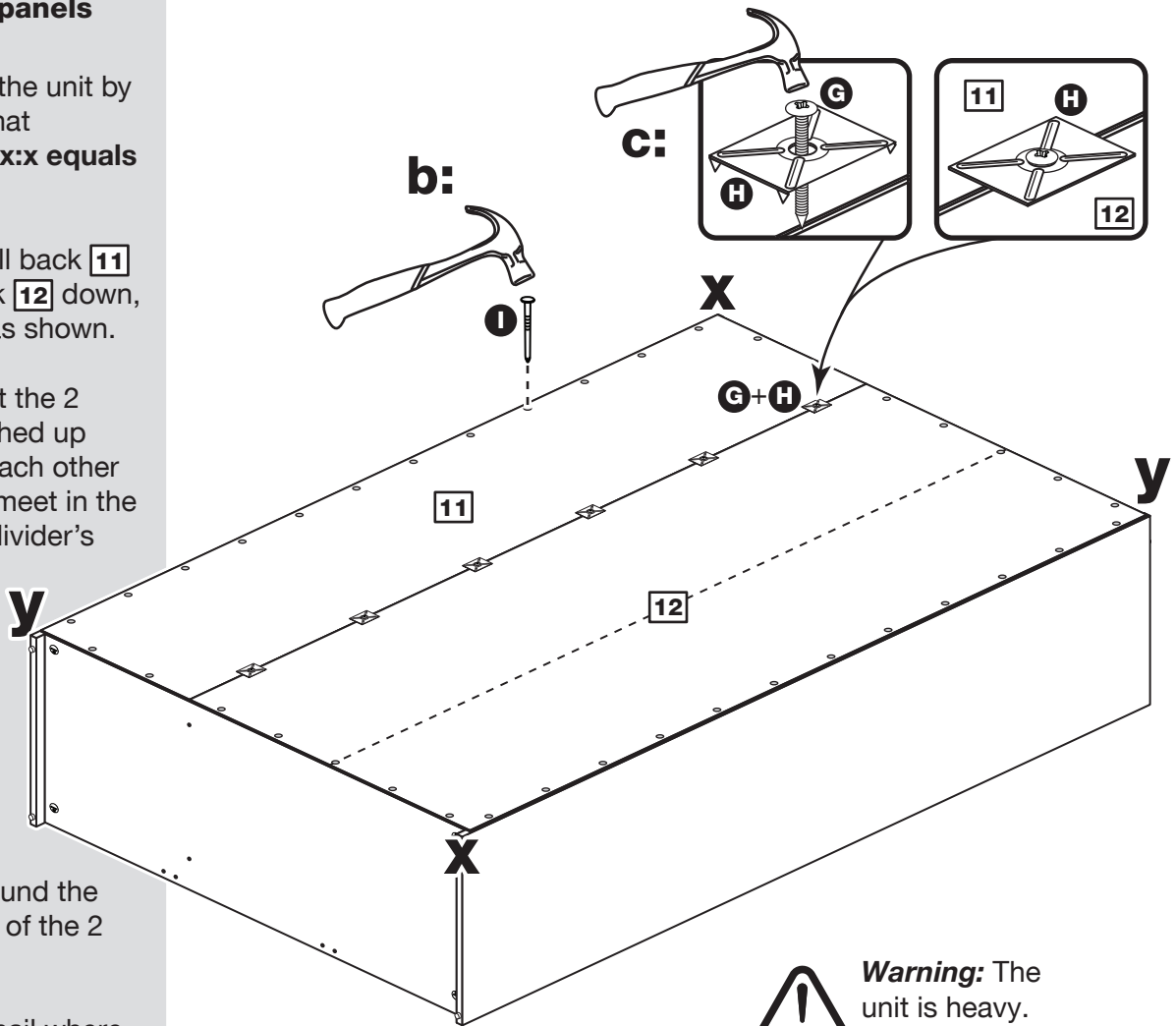

Warning: The unit is heavy. Lift with care.

Note: If ever you need to take the backs off to dismantle the unit, the nail screws can be taken out using a screwdriver.

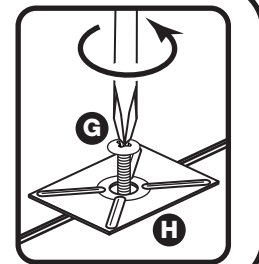

Assembly Instructions

Step 14

Fit the hanging rail and shelves

Push the hanging rail **7** into the rail holders **K** fitted to the side panels.

For each of the 3 shelves **6**, insert 4 shelf studs **C**.

Lower the 3 shelves **6** down onto the shelf studs **C**.

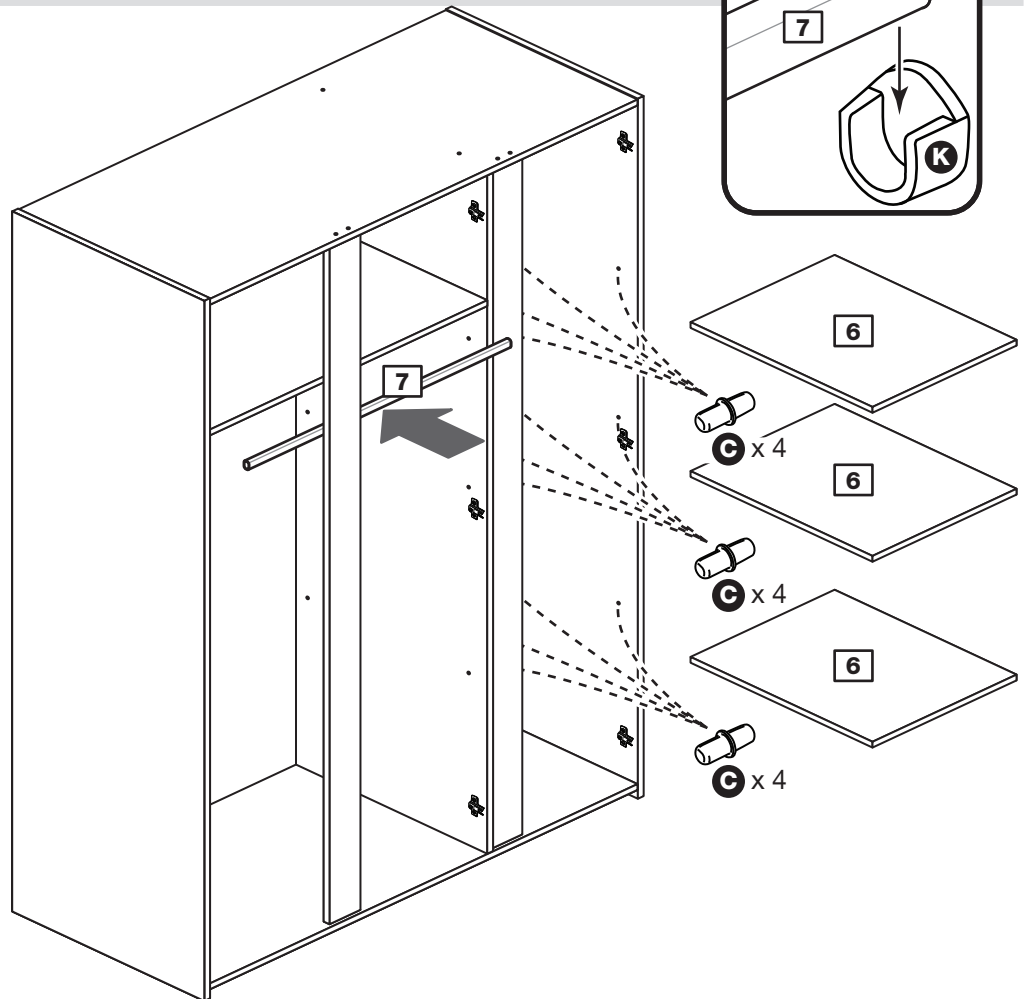

Step 15

Prepare the 3 doors

Lay the doors down onto a soft, smooth surface.

Push fit 3 hinges **N** into each plain door **9** and the mirror door **10**.

Secure each hinge with 2 screws **F**.

Note: Before securing with the screws, make sure that the hinges are positioned at 90 degrees with the front edge of the door.



Warning:
Glass! Handle with care

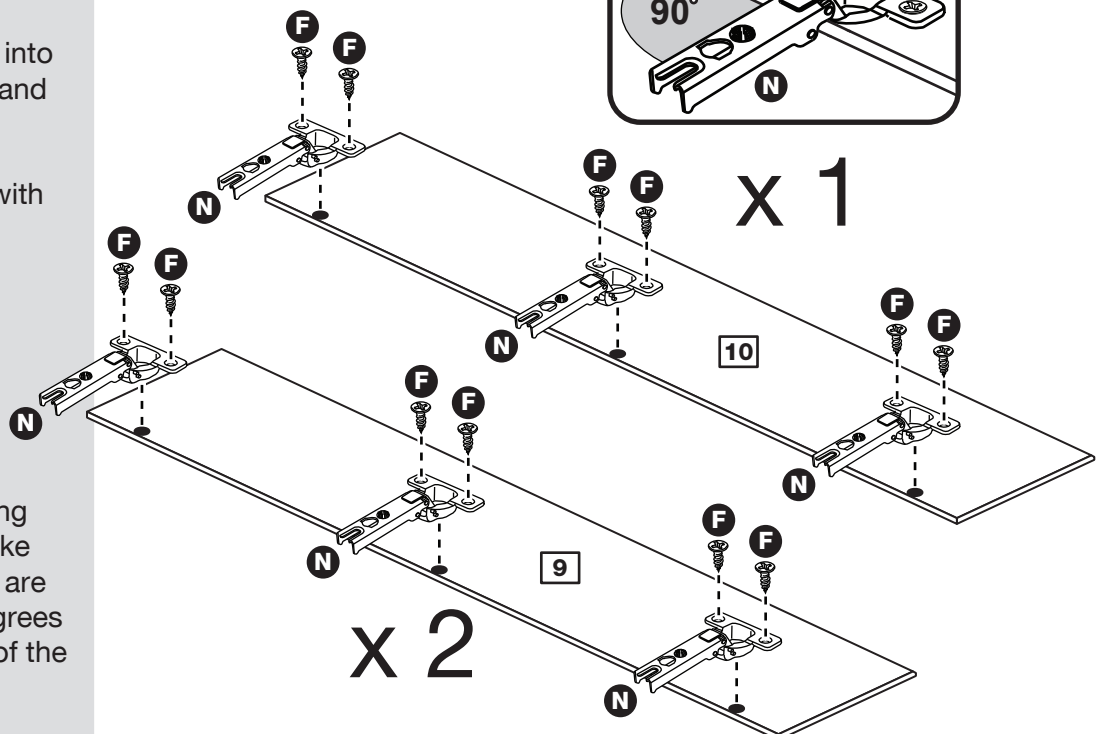
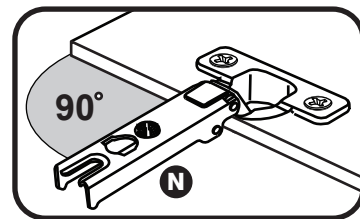

Assembly Instructions

Step 16

Fit the 3 doors

Note: The easiest way to attach each door **9** and **10** is to fit the top hinge first, then align and fit the other hinges.

a: Push the hinge **N** onto the front part of the hinge plate **M**. The recess at the bottom of screw B goes into the slot in the hinge plate.

b: Keep the hinge **N** FLAT against the hinge plate **M** as you slide it across as far as it will go. Tighten screw A.

c: The hinge **N** must be flat against the hinge plate **M** prior to any adjustment.

d: The hinge **N** must NOT be AT AN ANGLE to the hinge plate **M** when assembled. This would indicate that the recess at the bottom of screw B had not located in the slot in the hinge plate and the hinge would not be secure. Remove the hinge from the hinge plate and then re-assemble being careful to follow instructions a-c.

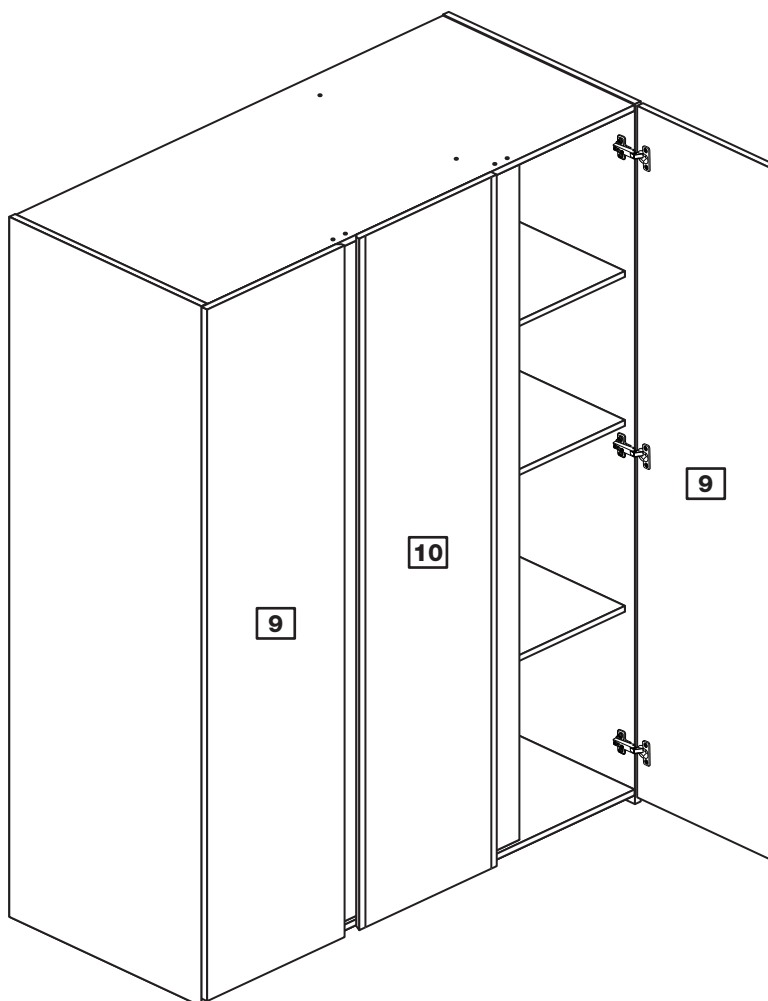
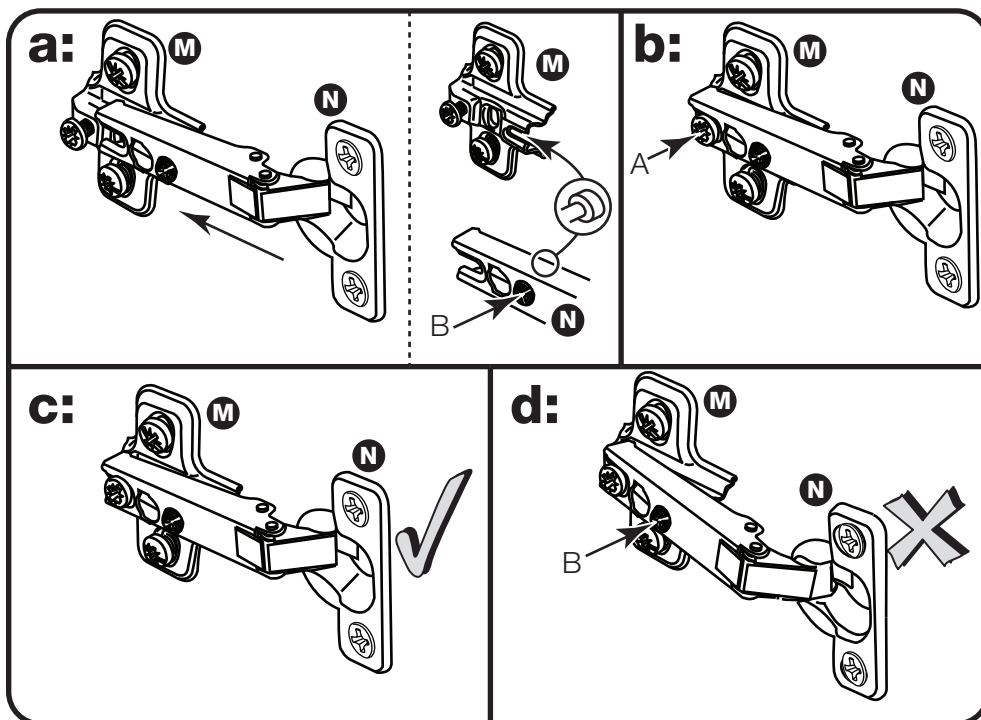

Assembly Instructions

Step 17

Adjust the doors if needed

a: Before adjusting the doors, use a spirit level to check the base (or top) of the unit is level, front-to-back and side-to-side in the 3 positions shown. Use suitable packing pieces (not supplied) to make the unit level BEFORE making any adjustment to the hinges, as shown.

b: Height adjustment.

Loosen screws A on hinge plates and move door up or down as required. Retighten screw A.

c: Forward and Back adjustment.

Loosen screw B on hinge plate and move door in or out as required. Retighten screw B.

d: Sideways adjustment.

To move door 'out' loosen screw C. To move door 'in' tighten screw C.

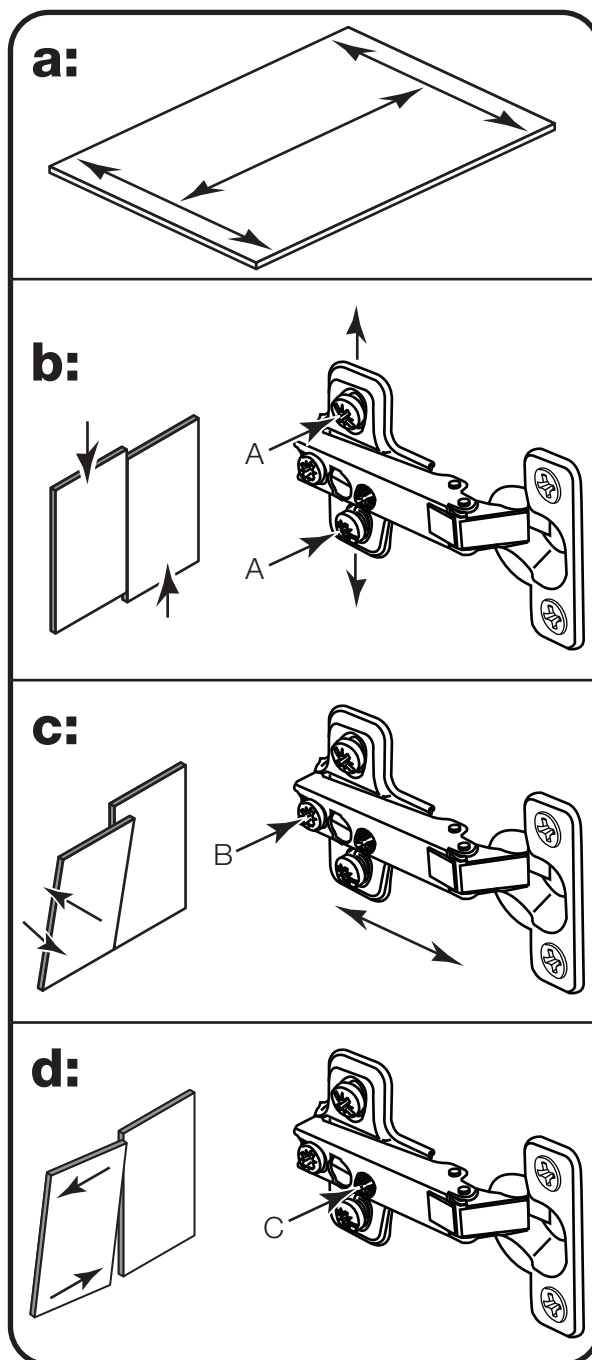

Assembly Instructions

Step 18

Fit the overbalance protector

To prevent possible overbalancing we recommend that this unit is secured to a suitable wall by use of the overbalance protector kit **L** fitted to the unit or, an alternative fixing method of your choice.

Wall fixings are not supplied as they will need to suit the wall type.

Note: Take care when drilling the wall that you do not drill into any pipes, wires etc. If in doubt, consult an expert.

Assembly is complete

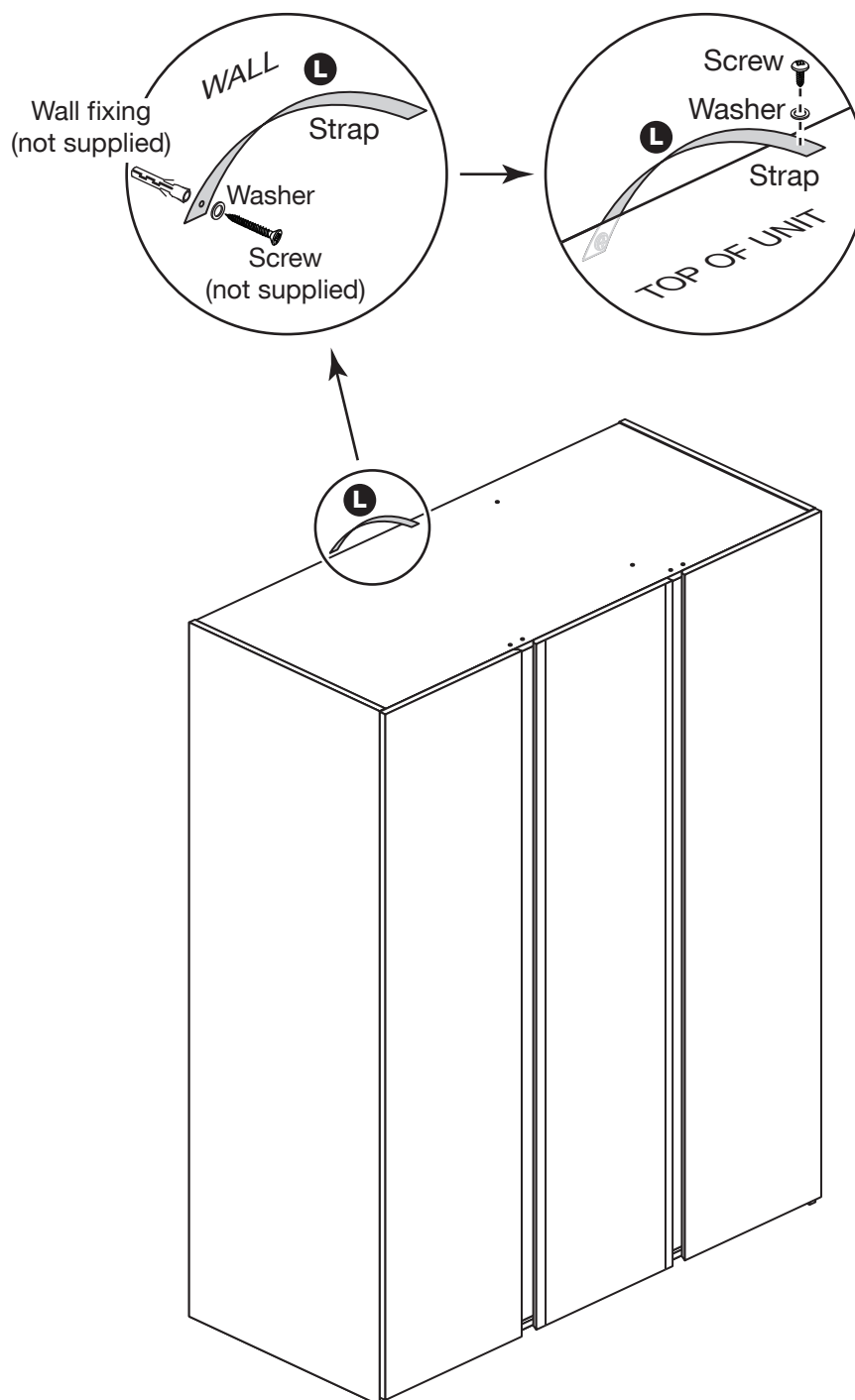

If you need help or have damaged or missing parts, call the Customer Helpline: 03456 400800 and quote the reference numbers on the component pages.

Argos Ltd, 489-499 Avebury Boulevard, Central Milton Keynes, MK9 2NW

IMPORTANT INFORMATION ABOUT THIS PRODUCT

This product complies with the requirements of BS 7449:1991 and has been manufactured by DECORATIVE PANELS FURNITURE LTD, TEESSIDE INDUSTRIAL ESTATE, THORNABY-ON-TEES, CLEVELAND, TS17 9LT.

The product code for this unit and the item code(s) for the glass components are listed in the Assembly Instructions along with a description of the type of glass used. All clear/tinted glass complies with the requirements of BS 6206 Class A. All mirrors comply with the requirements of BS 6206 Class C. If the glass component contained in this unit is chipped or broken consult the furniture manufacturer, retailer, or agent with regard to obtaining a manufacturing specification and shape for replacement glass quoting the unit description and batch number or date of manufacture.

Do not place very hot or very cold items against or in close proximity to glass surface(s) unless adequately thick insulating material is used to prevent such items coming in contact with the glass.

Do not strike the glass with hard or pointed items.

Do not sit or stand upon horizontal glass surfaces.

When cleaning glass panels use a damp cloth or leather with washing up liquid or soft soap if necessary - do not use washing powders or any other substance containing abrasives since these substances scratch glass.

If stated in the instruction leaflet, it is essential that this unit is fixed to a wall.

KEEP THESE INSTRUCTIONS FOR FUTURE USE