

# Zest - 4 Drawer Chest

Assembly Instructions - Please keep for future reference

239/6293

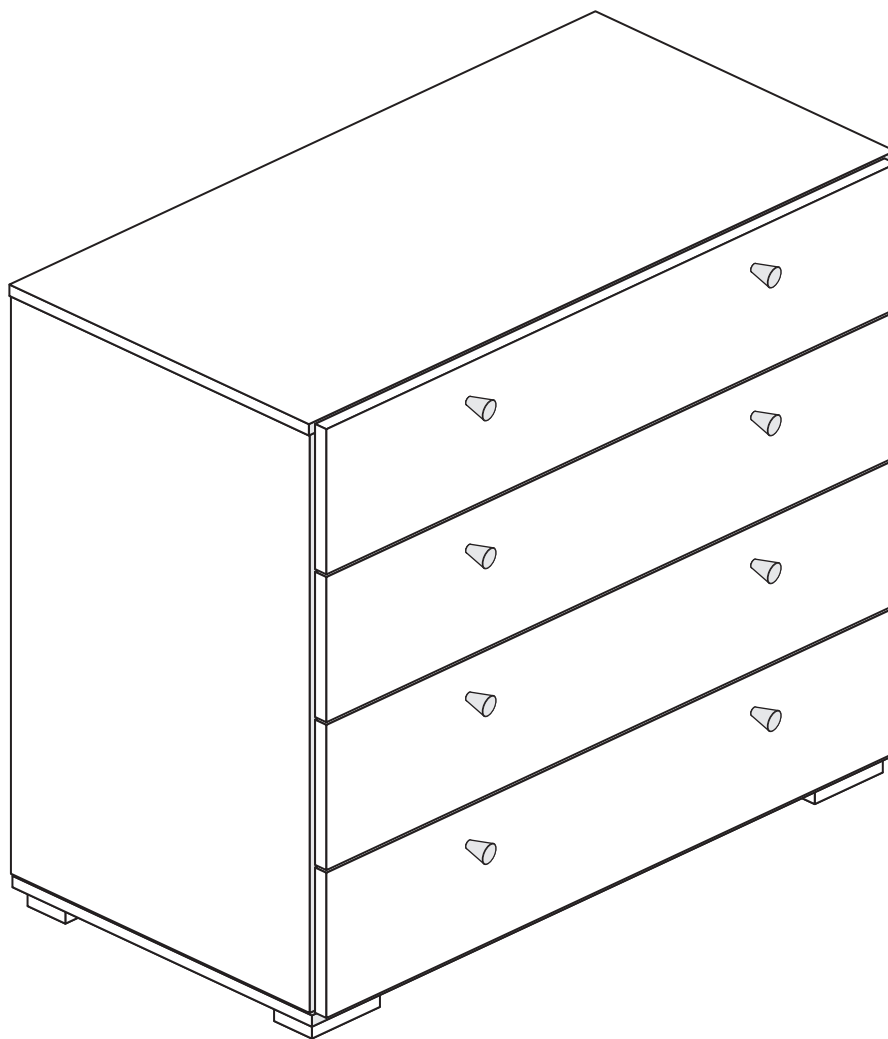

## Dimensions

Width - 77.5cm

Depth - 40cm

Height - 81.5cm



**MADE IN  
BRITAIN**

**Important** - Please read these instructions fully before starting assembly

If you need help or have damaged or missing parts, call the **Customer Helpline: 08456 400800**



# Safety and Care Advice

**Important - Please read these instructions fully before starting assembly**

- **Warning:** This unit weighs approximately 30kgs. Please lift with care.

- Check you have all the components and tools listed on pages 1, 2 and 3.

- Remove all fittings from the plastic bags and separate them into their groups.

- Keep children and animals away from the work area, small parts could choke if swallowed.

- Parts of the assembly will be easier with 2 people.

- Make sure you have enough space to layout the parts before starting.

- Do not stand or put weight on the product, this could cause damage.

- Assemble the item as close to its final position (in the same room) as possible.

- Assemble on a soft level surface to avoid damaging the unit or your floor (use opened out unit carton).



- We do not recommend the use of power drill/drivers **for inserting screws**, as this could damage the unit. Only use hand screwdrivers.

- **Safety note:** It is recommended that this unit is secured to a wall using the bracket supplied.

- Dispose of all packaging carefully and responsibly.

## Care and maintenance

- Only clean using a damp cloth and mild detergent, do not use bleach or abrasive cleaners.

- From time to time check that there are no loose screws on this unit.

- This product should not be discarded with household waste. Take to your local authority waste disposal centre.

## Tools required

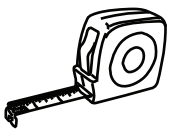

Rule



Cross-head screwdriver



Scissors



Hammer



Eye protection (when using a hammer or drill)



Electric drill (do not use for fitting screws)

**Note:** If required the next page can be cut out and used as reference throughout the assembly. Keep this page with these instructions for future reference.

# Components - Panels

If you have damaged or missing components, call the **Customer Helpline: 08456 400800** quoting the reference numbers below

Please check you have all the panels listed below

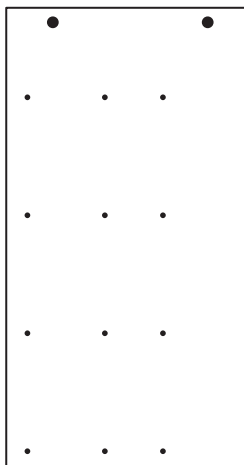

**1** Left Side (D2953A)  
(765 x 395mm)

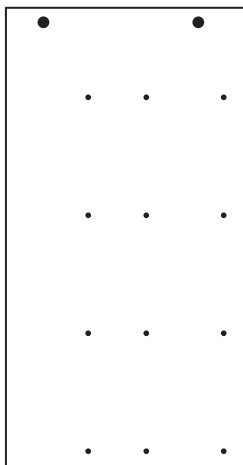

**2** Right Side (D2954A)  
(765 x 395mm)

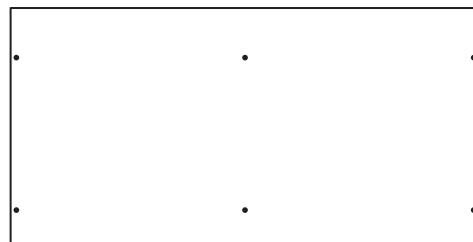

**3** Top (D2952A)  
(775 x 396mm)



**4** Base (D2955A)  
(775 x 395mm)

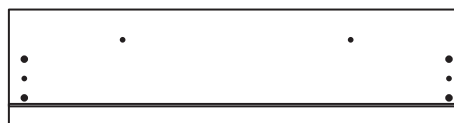

**5** Drawer Front (D2956A)  
(753 x 192mm) x 4



**6** Left Drawer Side (W370-124LH)  
(370 x 124mm) x 4



**7** Right Drawer Side (W370-124RH)  
(370 x 124mm) x 4



**8** Drawer Back (W689-124)  
(689 x 124mm) x 4



**9** Drawer Base (T700-367)  
(700 x 367mm) x 4

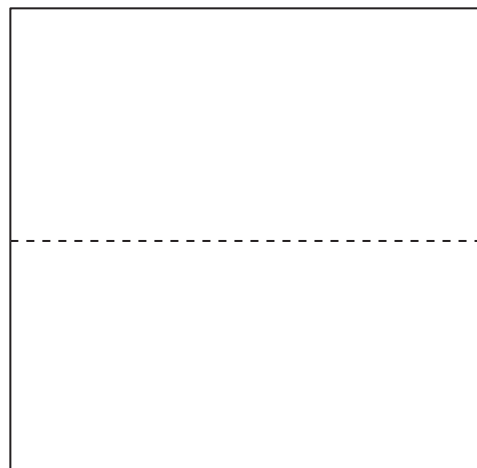

**10** Back (X791-769)  
(791 x 769mm)











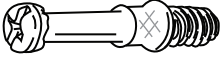





# Components - Fittings

If you have damaged or missing components, call the **Customer Helpline: 08456 400800** quoting the reference numbers below

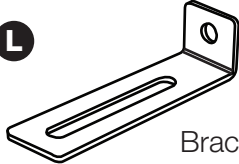
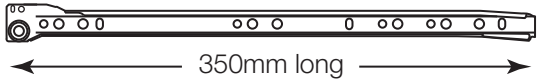
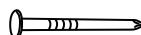
Please check you have all the fittings listed below

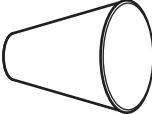
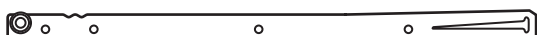
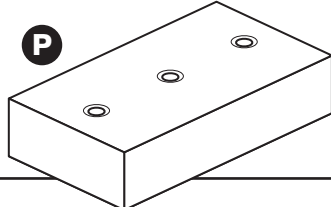
**Note:** The quantities below are the correct amount to complete the assembly. In some cases more fittings may be supplied than are required.

<p><b>A</b> </p> <p>Metal dowel (F901) x 12</p>	<p><b>B</b> </p> <p>Large locking nut (F900) x 4</p>	<p><b>C</b> </p> <p>Small locking nut (F3) x 8</p>
<p><b>D</b> </p> <p>40mm Screw (F910) x 4</p>	<p><b>E</b> </p> <p>38mm Screw (F81) x 8</p>	<p><b>F</b> </p> <p>32mm Screw (F72) x 8</p>
<p><b>G</b> </p> <p>13mm Screw (F52) x 24</p>	<p><b>H</b> </p> <p>13mm Screw (F63) x 24</p>	<p><b>I</b> </p> <p>13mm Screw (F79) x 1</p>
<p><b>J</b> </p> <p>Wedgex (F639) x 16</p>	<p><b>K</b> </p> <p>Knock-in Peg (F171GY) x 16</p>	<p><b>L</b> </p> <p>Bracket (F327) x 1</p>
<p><b>M a</b>  L Runner (F159) x 4 ← 350mm long →</p>	<p><b>N</b> </p> <p>Nail (F51) x 22</p>	
<p><b>M b</b>  R Runner (F160) x 4</p>	<p><b>O</b> </p> <p>Handle (F894GRN) x 8</p>	
<p><b>M c</b>  L Runner (F161) x 4</p>	<p><b>P</b> </p> <p>Foot (F233) x 4</p>	
<p><b>M d</b>  R Runner (F162) x 4</p>		

Ruler - Use this ruler to help correctly identify the screws

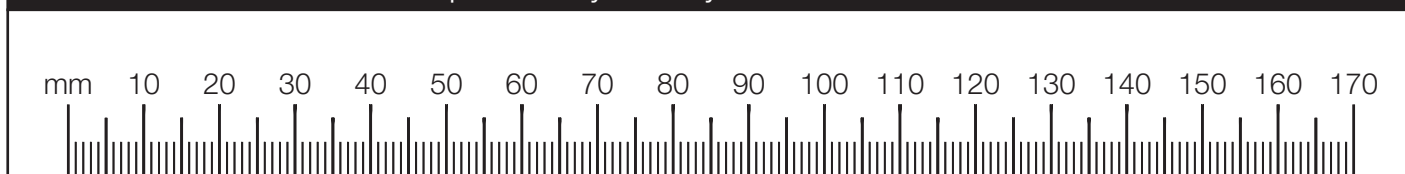

# Assembly Instructions

If you have damaged or missing components, call the Customer Helpline: 08456 400800 quoting the reference numbers below

## Step 1

### Prepare the 4 drawer fronts

Screw 2 metal dowels **A** into each of the drawer fronts **5**.

**Note:** Tighten the metal dowels up fully against the panels.

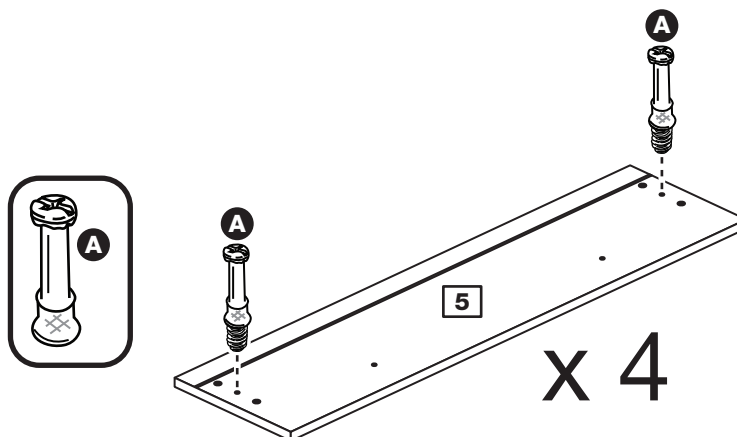

## Step 2

### Prepare the drawer sides

Insert a small locking nut **C** into the hole shown on the left drawer side **6** and the right drawer side **7**.

**Note:** The arrow on the locking nut **must** point towards the hole in the edge of the panel.

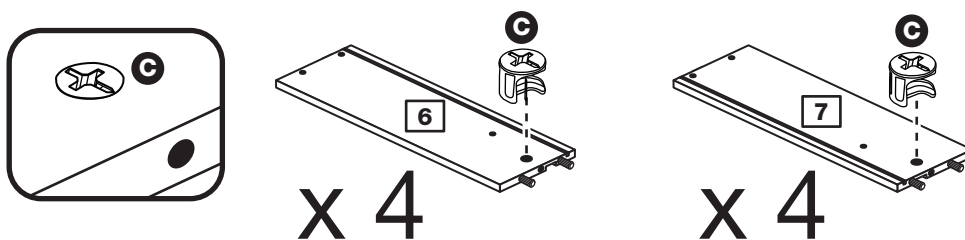

## Step 3

### Attach the drawer sides to the drawer fronts

Push the left drawer sides **6** and right drawer sides **7** onto the back of the drawer fronts **5**.

Turn the small locking nuts **C** on the left drawer side **6** and right drawer side **7**.

**Note:** Turn the locking nuts **C** clockwise to secure panels - more than 1/2 a turn.

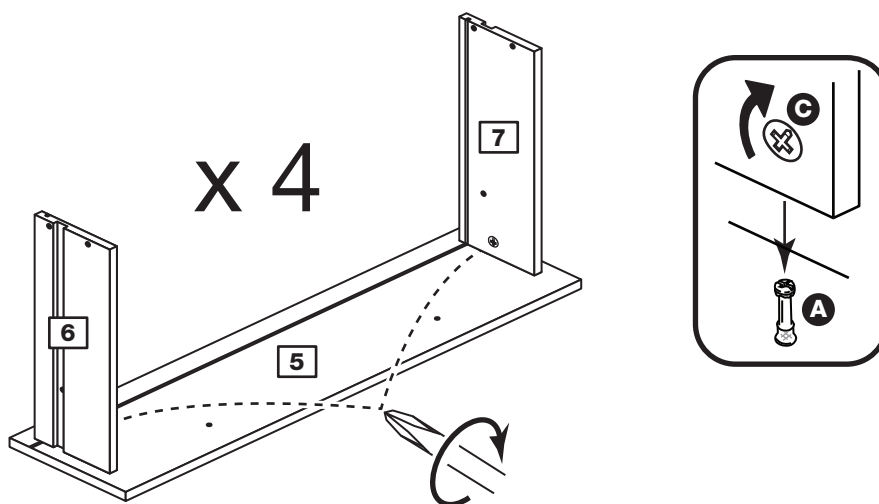

# Assembly Instructions

## Step 4

### Fit the drawer base

Slide the drawer base **9** down the grooves in the drawer sides **6** and **7** and down into the groove in the drawer front **5**.

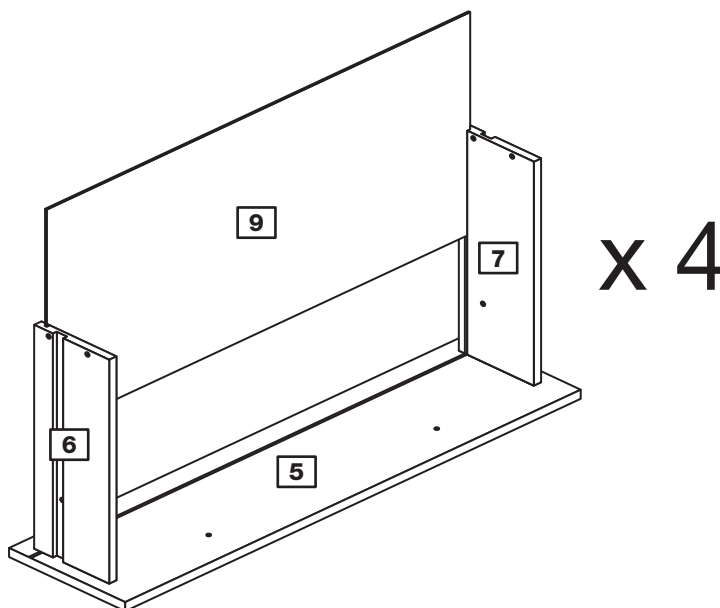

## Step 5

### Fit the drawer back

Fit the drawer back **8** between the drawer sides **6** and **7**. Make sure that the drawer base **9** fits into the groove in the drawer back **8**.

Hold the drawer back **8** in position and tap the knock-in pegs **K** through the holes in the drawer sides **6** and **7**.

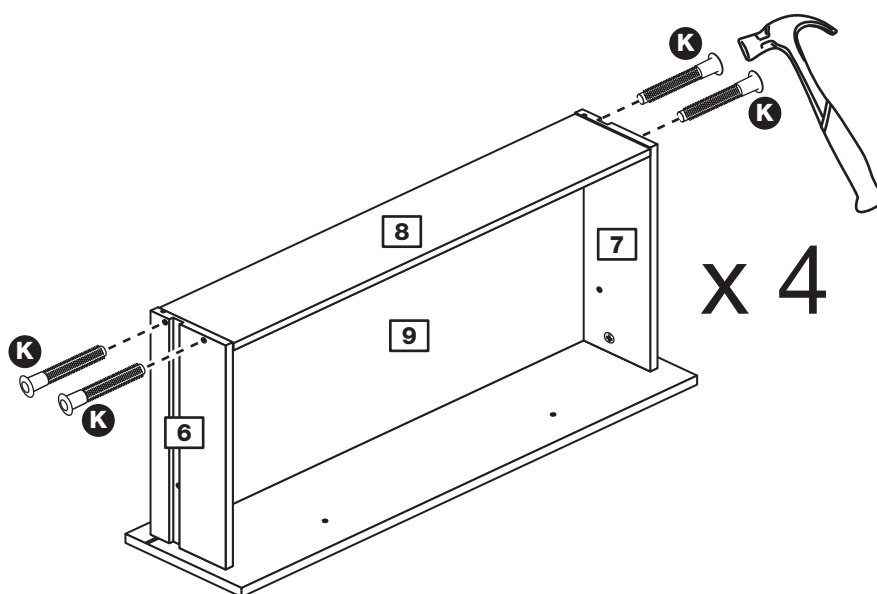

## Step 6

### Attach the handles

Attach 2 handles **O** to each of the drawer fronts **5** using screws **F**.

**Note: Do not overtighten the screw.**

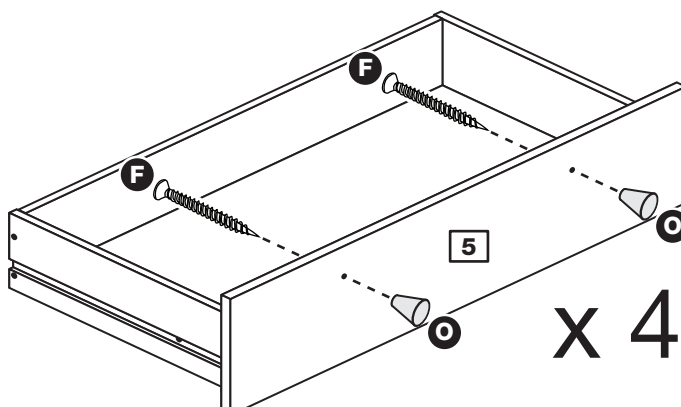

**Note:** Make sure that you use the 32mm screws (refer back to the fittings page).

# Assembly Instructions

## Step 7

### Fit the wedgexes

Turn the drawer assemblies over and slide 4 wedgexes **J** into the front and back grooves, as shown, and tighten up the screws.

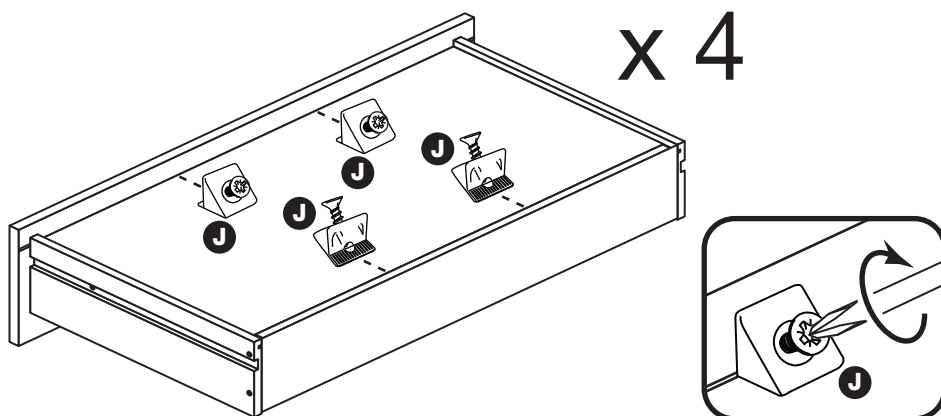

## Step 8

### Fit runners to the drawers

Fit the runner **M c** to the bottom edge of the left drawer side **6**, as shown, making sure that it is pushed up against the back of the drawer front **5**. Use a bradawl to mark the fixing positions, then secure with 2 screws **H**.

Fit the runner **M d** to the bottom edge of the right drawer side **7** using the same method.

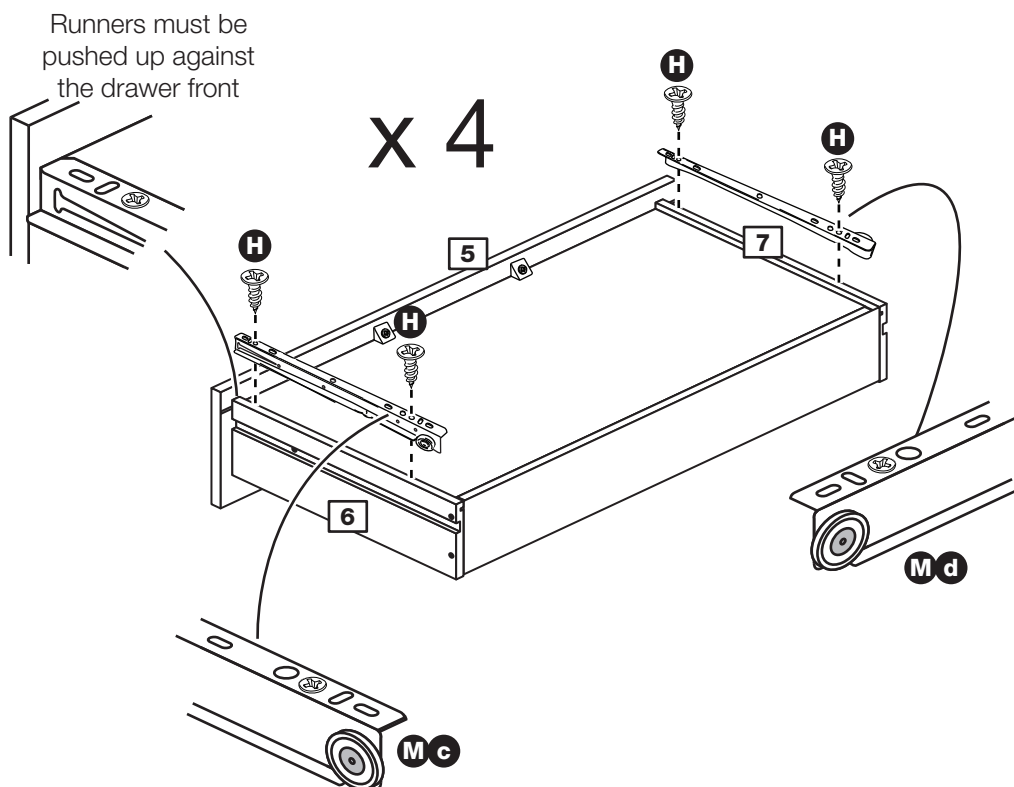

# Assembly Instructions

## Step 9

### Prepare the left side

Insert 2 large locking nuts **B** into the left side **1**.

**Note:** The arrow on the locking nut **must** point towards the hole in the edge of the panel.

Fit 4 runners **Ma** to the left side **1**.

The 1st screw **G** uses the 2nd hole in from the front of the runner.

The 2nd and 3rd screws **G** use the holes that line up with the other panel holes.

Fit a screw **H** into the 2nd hole in at the top of the runner **Ma**.

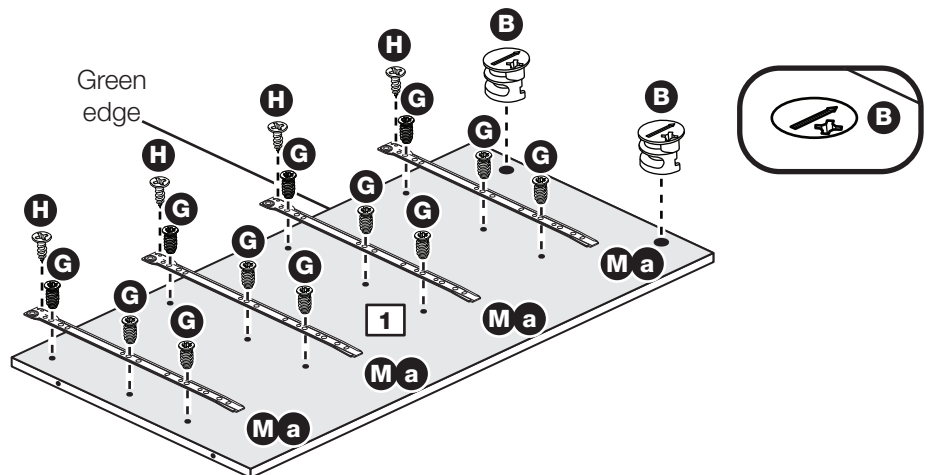
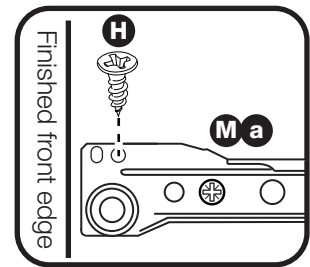
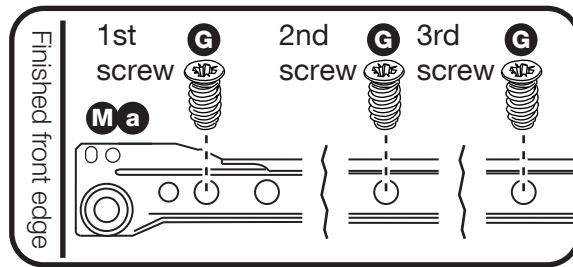

## Step 10

### Prepare the right side

Insert 2 large locking nuts **B** into the right side **2**.

Fit 4 runners **Mb** to the right side **2**.

The 1st screw **G** uses the 2nd hole in from the front of the runner.

The 2nd and 3rd screws **G** use the holes that line up with the other panel holes.

Fit a screw **H** into the 2nd hole in at the top of the runner **Mb**.

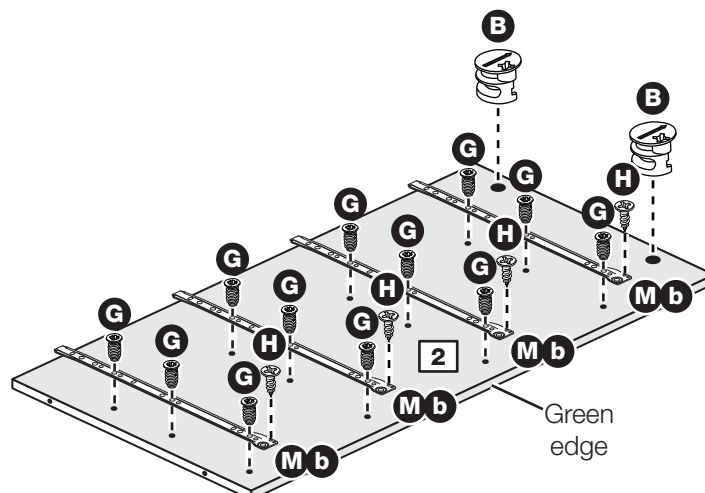
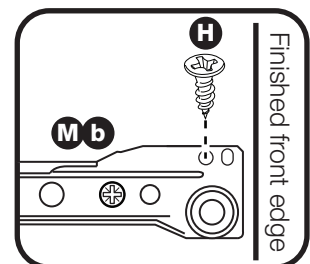
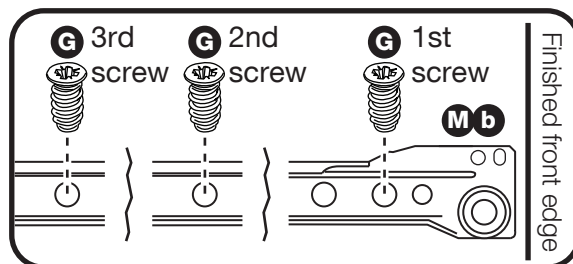



# Assembly Instructions

## Step 11

### Prepare the top

Screw 4 metal dowels **A** into the top **3**.

Fix the bracket **L** in the middle of the top **3**, flush to the back edge using screw **I**.

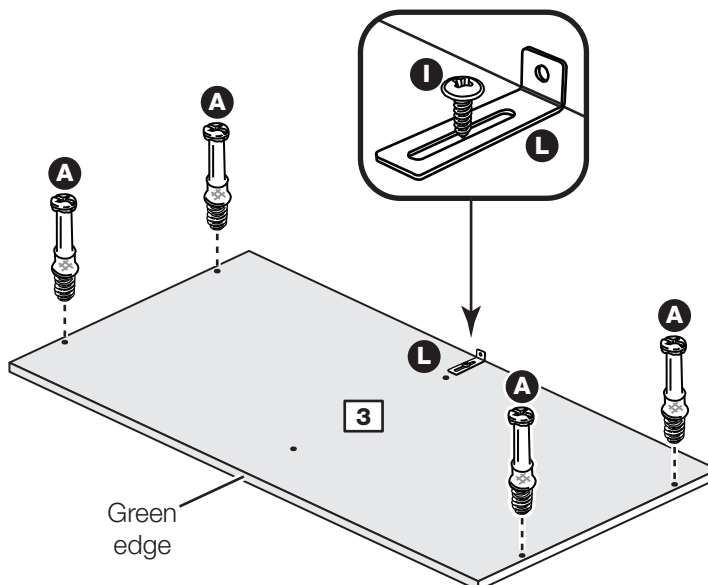

## Step 12

### Fit the top

Push the top **3** onto the assembly.

Use a screwdriver to tighten the 4 large locking nuts **B** fitted to the left side **1** and right side **2**.

**Note:** Turn the large locking nuts **B** as far as they will go - more than 1/2 a turn.

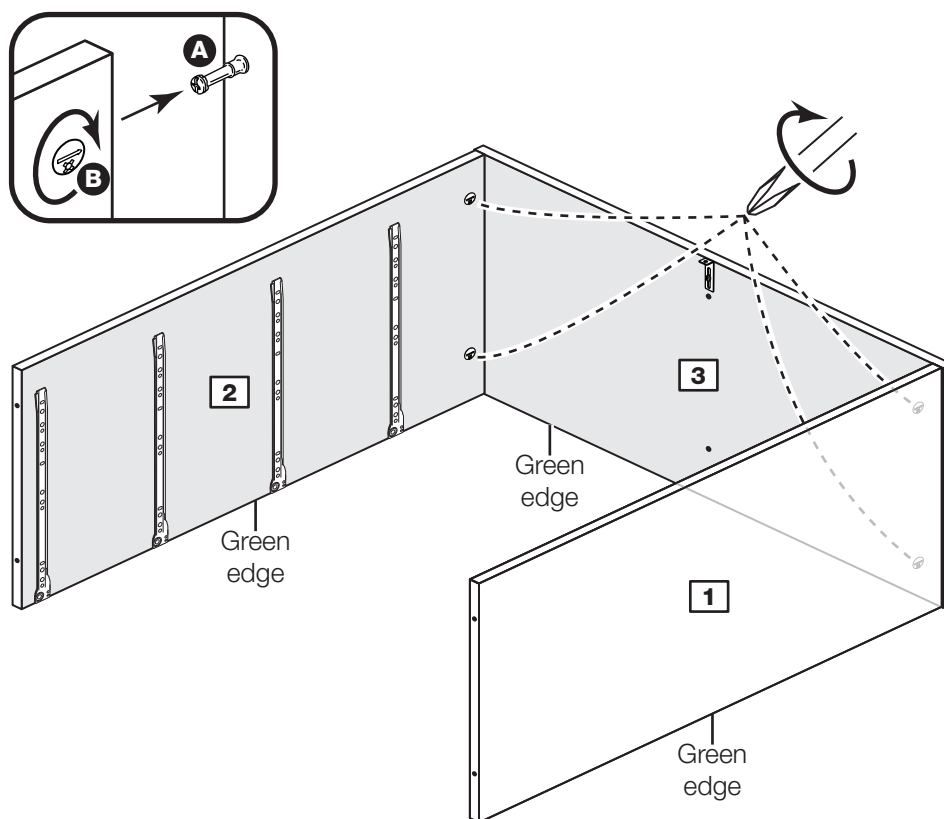

# Assembly Instructions

## Step 13

### Fit the base

Fit the base **4** onto the sides **1** and **2** using 4 screws **D**.

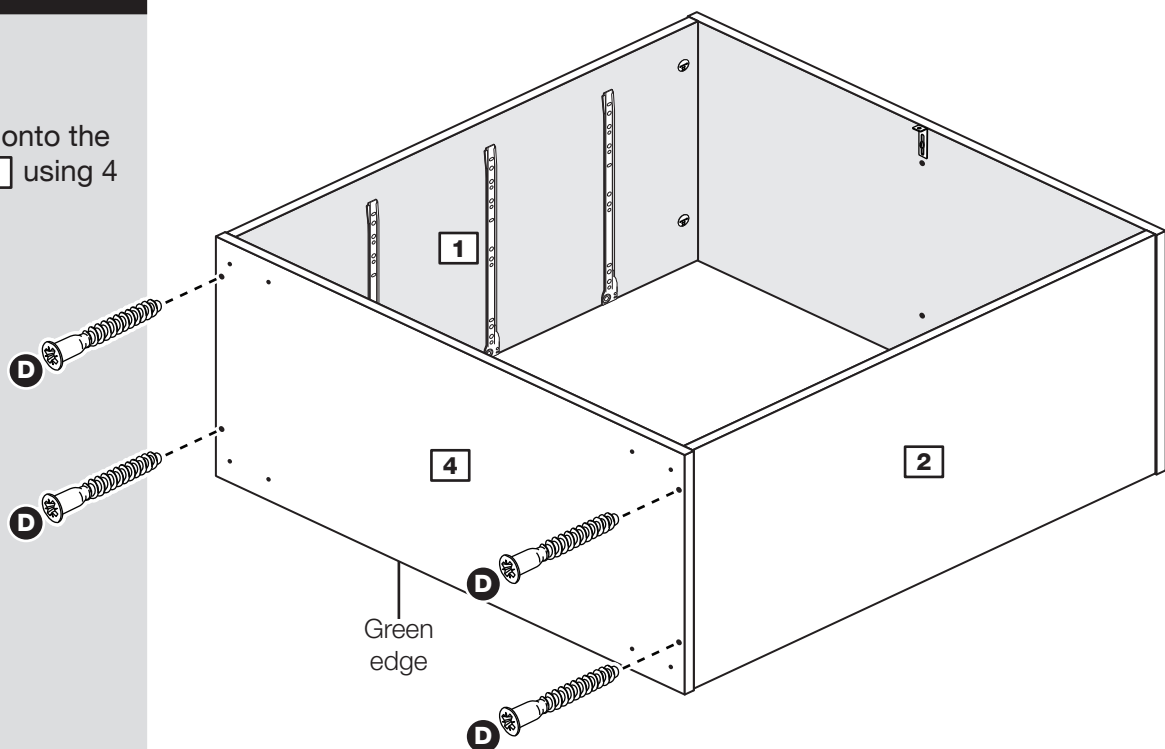

## Step 14

### Fit the feet

Fit the feet **P** to the base **4** using screws **E**.

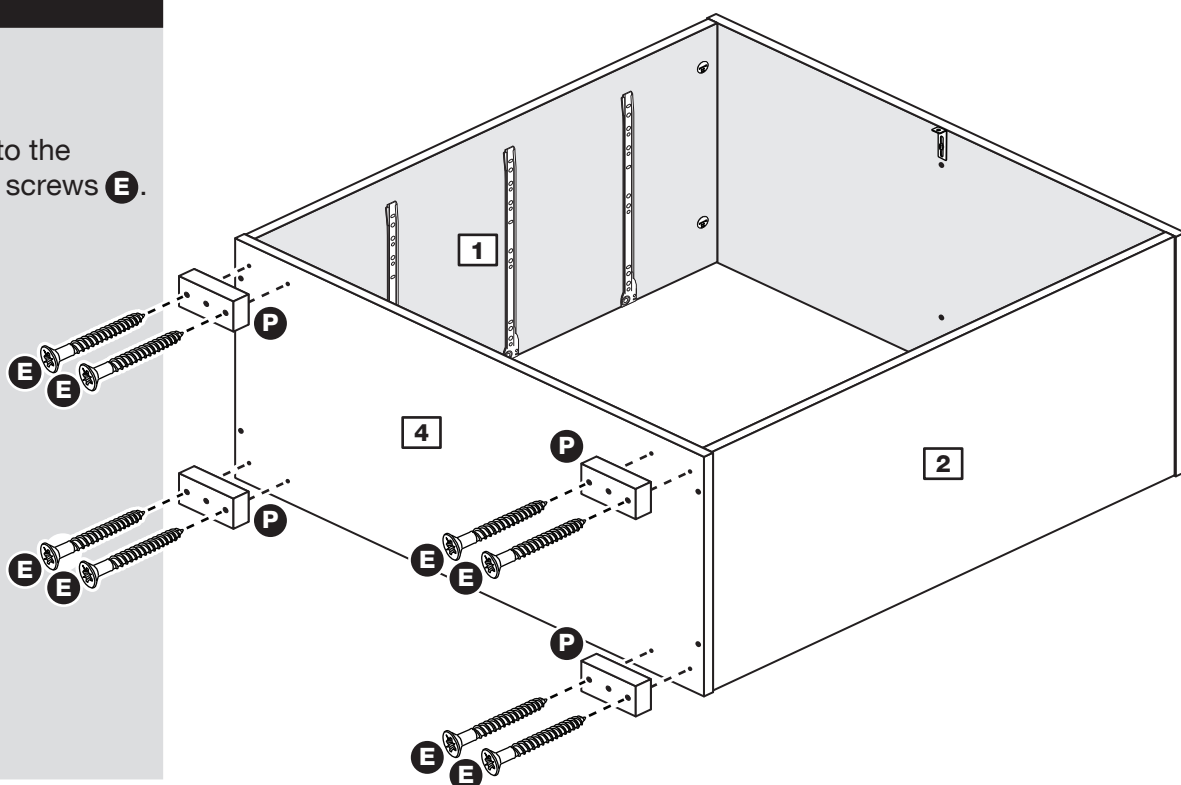

# Assembly Instructions

## Step 15

### Fit the back

**a:** Square up the unit by making sure that measurement **x** to **x** equals **y** to **y**.

**b:** Place the back **10** onto the unit.

Nail **N** around the outside edges of the back **10**.

**Note:** Nails should be spaced about 150mm apart.

**Stand the unit up for the next step.**



**Warning:** The unit is heavy. Lift with care.

**a:** The measurement from top corner X to bottom corner X must be equal to the measurement from top corner Y to bottom corner Y

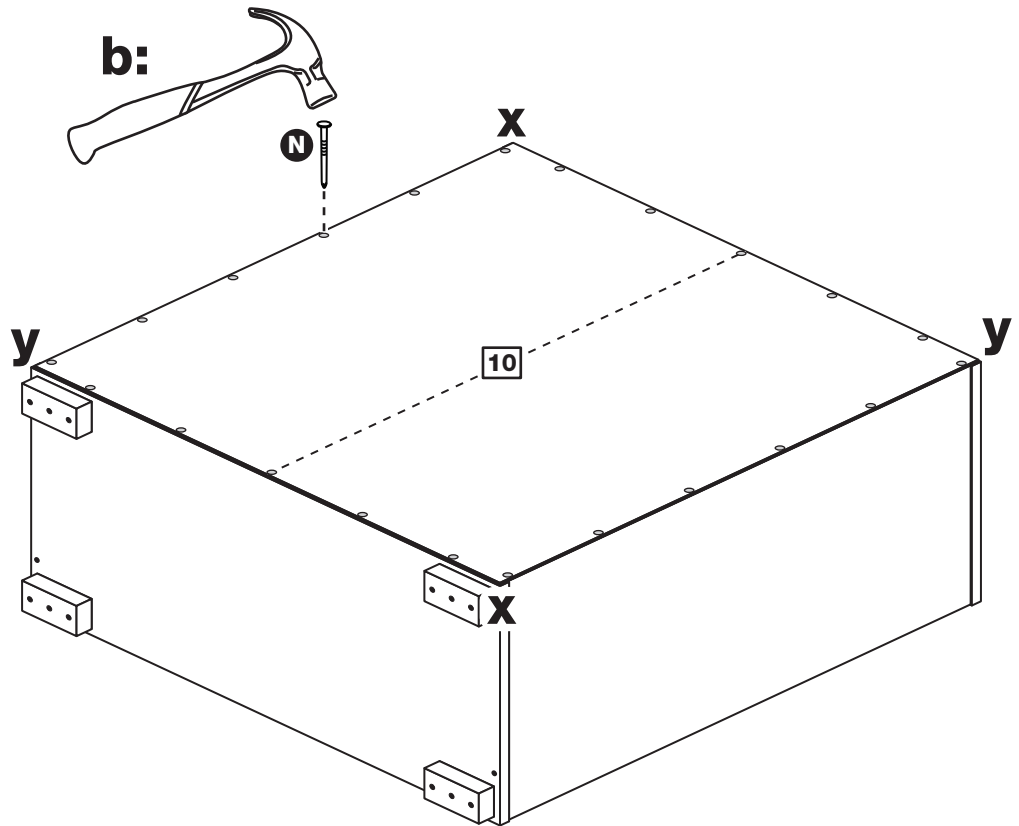

## Step 16

### Secure unit to a wall

To prevent possible overbalancing we recommend that this unit is secured to a suitable wall by use of the metal bracket **L** fitted to the top **3**.

Fixings are not supplied as they will need to suit the wall type, and the length of screw will depend on the distance of the back of the unit to the wall.



**Warning:** Take care when drilling the wall that you do not drill into any pipes, wires etc. If in doubt, consult an expert.

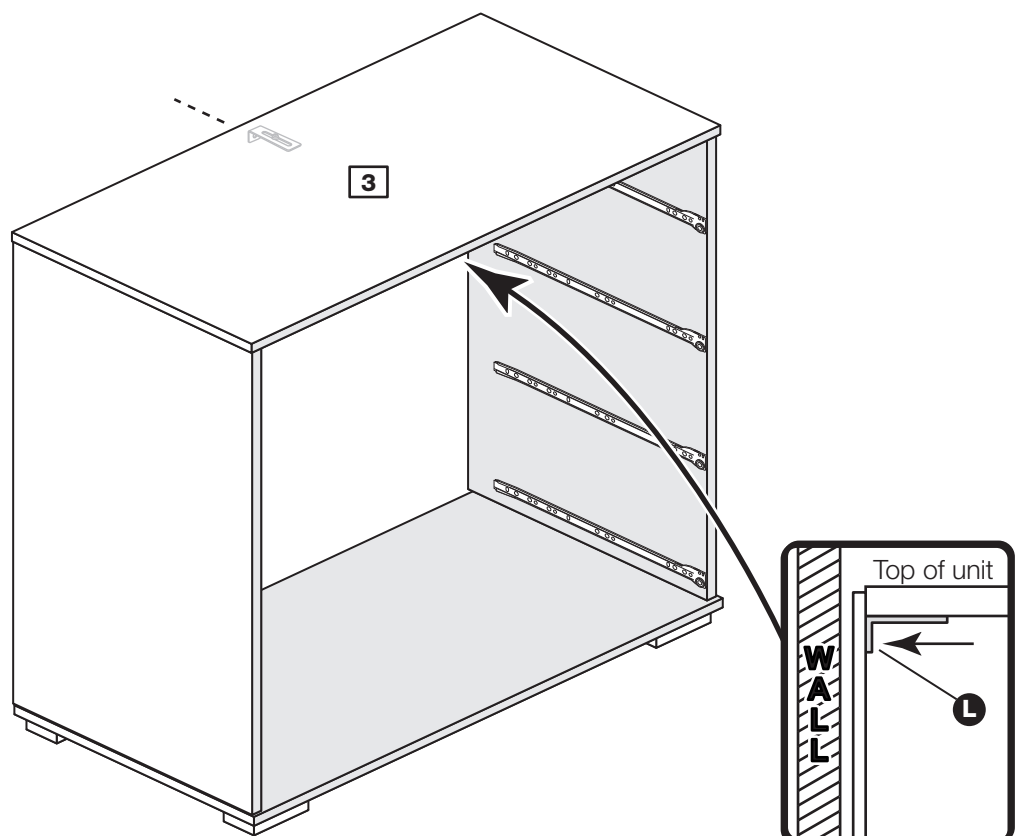

# Assembly Instructions

## Step 17

### Fit the drawers

Slide the wheels of the runners fitted to the drawers, over the wheels of the runners fitted to the side panels and push the drawers into position.

### Assembly is complete

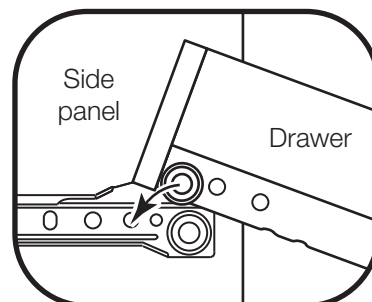
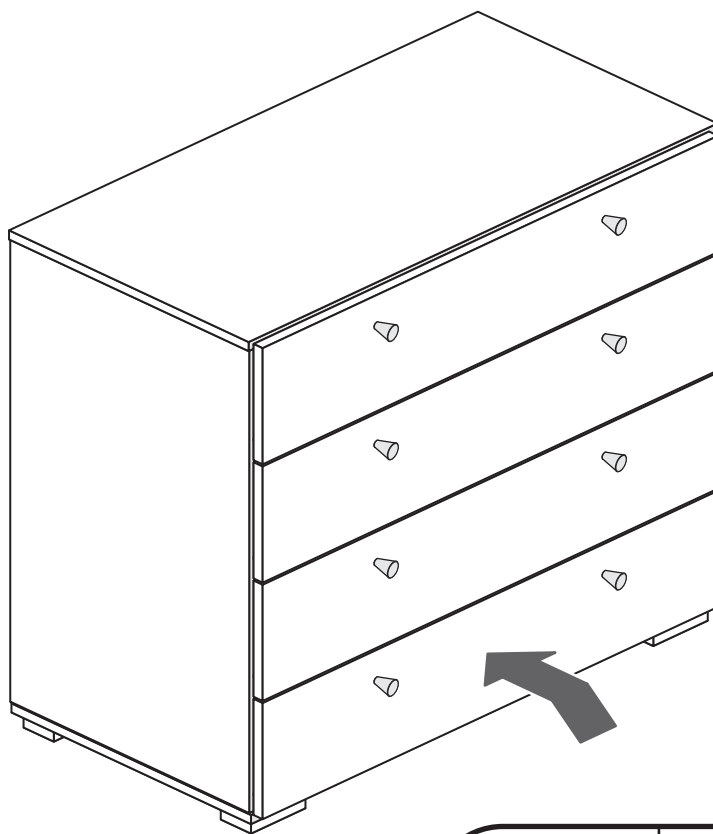

If you need help or have damaged or missing parts, call the **Customer Helpline: 08456 400800** and quote the reference numbers on the component pages.

Argos Ltd, 489-499 Avebury Boulevard, Central Milton Keynes, MK9 2NW