

Capella - 3 Drawer 3 Door Robe

Assembly Instructions - Please keep for future reference

255/7276

257/9838

239/2682

258/4517

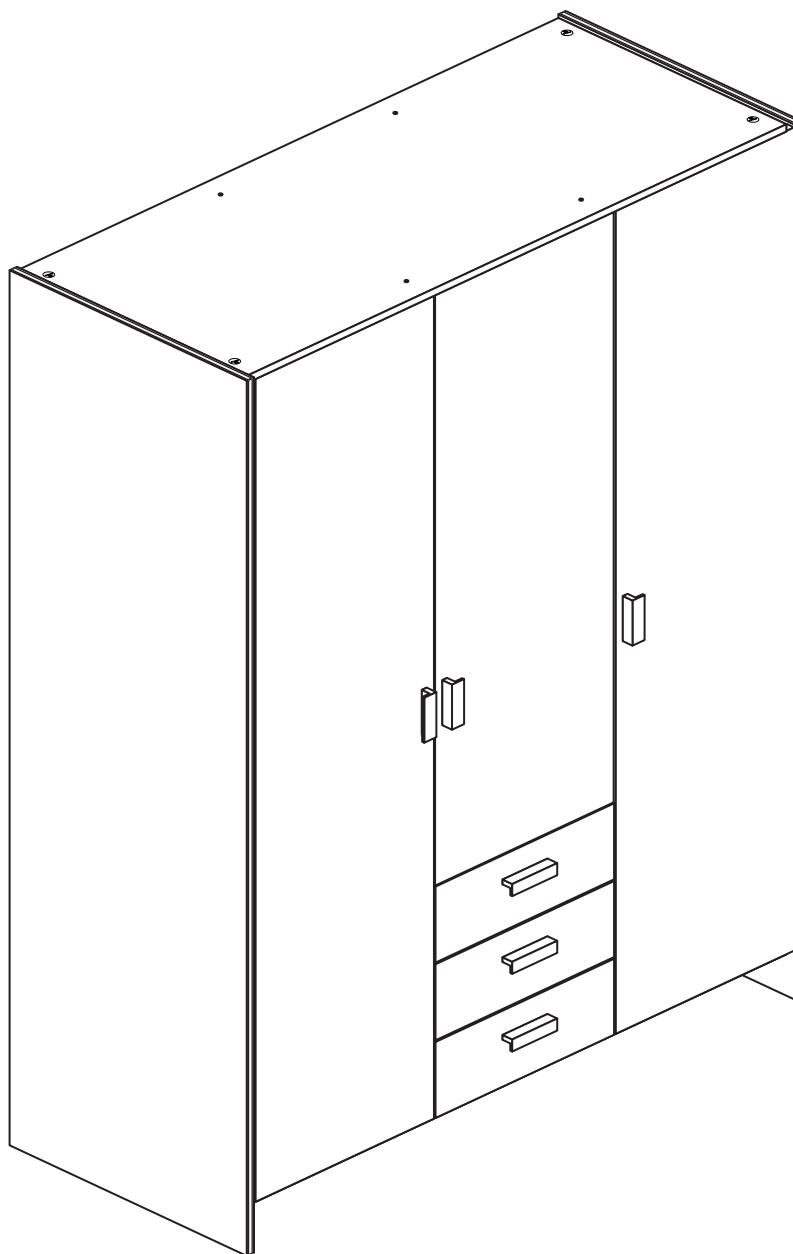

Dimensions

Width - 115cm

Depth - 49cm

Height - 181cm



MADE IN
BRITAIN

Important - Please read these instructions fully before starting assembly

If you need help or have damaged or missing parts, call the **Customer Helpline: 08456 400800**



Safety and Care Advice

Important - Please read these instructions fully before starting assembly

- **Warning:** This unit weighs approximately 77kgs. Please lift with care.
- Check you have all the components and tools listed on pages 2 and 3.
- Remove all fittings from the plastic bags and separate them into their groups.
- Keep children and animals away from the work area, small parts could choke if swallowed.
- Parts of the assembly will be easier with 2 people.

- Make sure you have enough space to layout the parts before starting.
- Do not stand or put weight on the product, this could cause damage.
- Assemble the item as close to its final position (in the same room) as possible.
- Assemble on a soft level surface to avoid damaging the unit or your floor (use opened out unit carton).



• We do not recommend the use of power drill/drivers **for inserting screws**, as this could damage the unit. Only use hand screwdrivers.







• **Safety note:** It is recommended that this unit is secured to a wall using the bracket supplied.

• Dispose of all packaging carefully and responsibly.

Care and maintenance

- Only clean using a damp cloth and mild detergent, do not use bleach or abrasive cleaners.
- From time to time check that there are no loose screws on this unit.
- This product should not be discarded with household waste. Take to your local authority waste disposal centre.

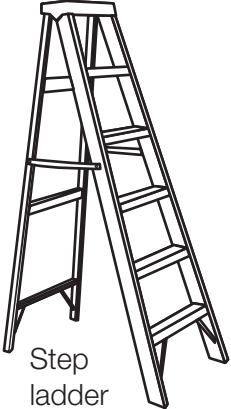
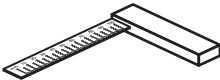
Tools required

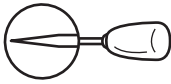
 Rule	 Spirit level	 Eye protection (when using a hammer or drill)	 Cross-head screwdriver	 Electric drill (only use when drilling into walls)	 Step ladder
 Square	 Scissors	 Hammer	 Bradawl		

Note: If required the next page can be cut out and used as reference throughout the assembly. Keep this page with these instructions for future reference.

Components - Panels

If you have damaged or missing components, call the **Customer Helpline: 08456 400800** quoting the reference numbers below

Please check you have all the panels listed below

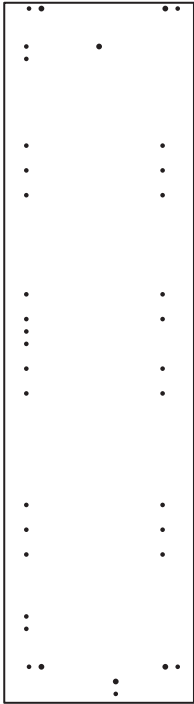

1 Left Side (D1013A)
(1808 x 490mm)

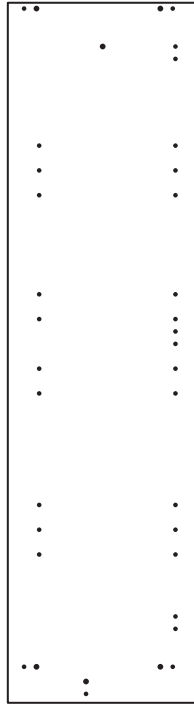

2 Right Side (D1014A)
(1808 x 490mm)

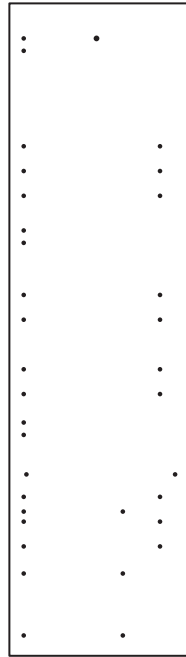

3 Long Divider (D1084A)
(1685 x 470mm)

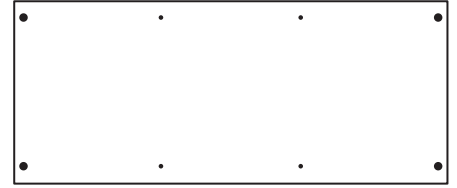

4 Top/Base (D1018A)
(1119 x 471mm) x 2



5 Plinth (D1024A)
(1119 x 85mm)

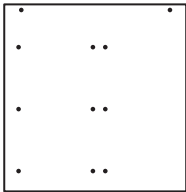

6 Short Divider (D1019A)
(483 x 470mm)



7 Fixed Shelf (D1020A)
(346 x 469mm)

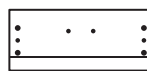

8 Drawer Front (D1022A)
(369 x 157mm) x 3

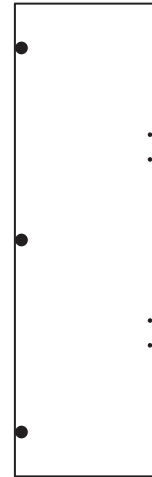

9 Centre Door (D1025A)
(1221 x 369mm)

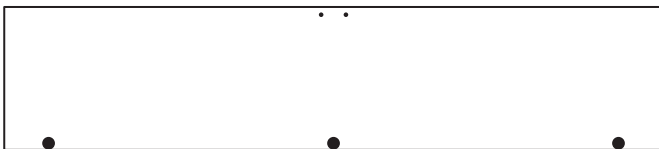

10 Outer Door (D1017A)
(1701 x 369mm) x 2

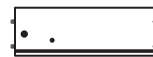

11 Left Drawer Side (W370-124LH)
(370 x 124mm) x 3

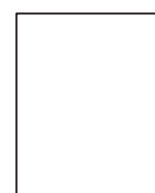

13 Loose Shelf (D1023A)
(369.5 x 469mm) x 3

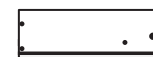

12 Right Drawer Side (W370-124RH)
(370 x 124mm) x 3

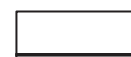

14 Drawer Back (W314-124)
(314 x 124mm) x 3



15 Drawer Base (T325-367)
(325 x 367mm) x 3



16 Hanging Rail (FHR723)
(723mm long)



17 Small Back (X831A)
(1711 x 392mm)

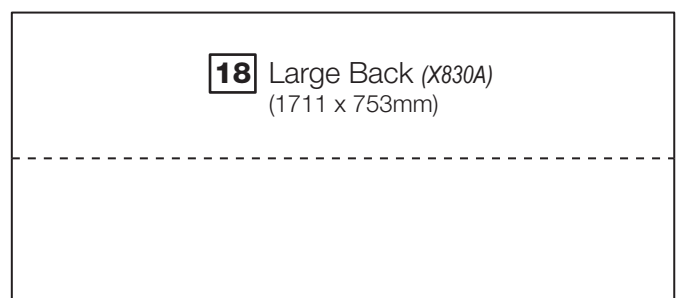

18 Large Back (X830A)
(1711 x 753mm)











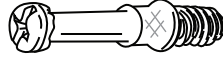
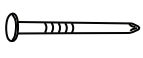







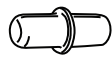
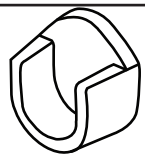
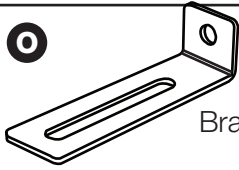
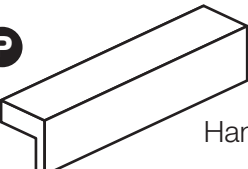

Components - Fittings

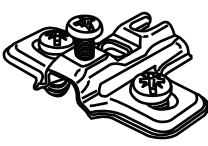
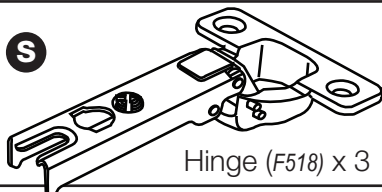
If you have damaged or missing components, call the **Customer Helpline: 08456 400800** quoting the reference numbers below

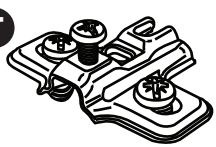
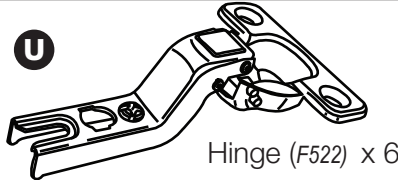
Please check you have all the fittings listed below

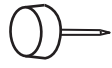
Note: The quantities below are the correct amount to complete the assembly. In some cases more fittings may be supplied than are required.

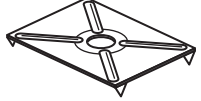
<p>A </p> <p>Wooden dowel (F22) x 10</p>	<p>B </p> <p>Metal dowel (F901) x 16</p>	<p>C </p> <p>Nail (F51) x 34</p>	
<p>D </p> <p>Large locking nut (F900) x 10</p>	<p>E </p> <p>Small locking nut (F3) x 6</p>	<p>F </p> <p>Knock-in Peg (F171) x 12</p>	
<p>G </p> <p>40mm Screw (F910) x 10</p>	<p>H </p> <p>25mm Screw (F50) x 12</p>	<p>I </p> <p>13mm Screw (F79) x 11</p>	
<p>J </p> <p>13mm Screw (F63) x 18</p>	<p>K </p> <p>9mm Screw (F74) x 6</p>	<p>L </p> <p>9mm Screw (F73) x 12</p>	
<p>M </p> <p>Shelf stud (F110) x 12</p>	<p>N </p> <p>Rail holder (F1014) x 2</p>	<p>O </p> <p>Bracket (F327) x 1</p>	
<p>P </p> <p>Handle (F930) x 6</p>	<p>Q </p> <p>Drawer runner (F1004) x 6</p>		
<p>R </p> <p>Hinge plate (F523) x 3</p>	<p>S  </p> <p>Hinge (F518) x 3</p>		
<p>T </p> <p>Hinge plate (F523) x 6</p>	<p>U  </p> <p>Hinge (F522) x 6</p>		
<p>V </p> <p>Wedgefix (F639) x 6</p>	<p>W </p> <p>Plastic Nail (F91) x 5</p>	<p>X </p> <p>Nail screw (F277) x 6</p>	<p>Y </p> <p>Back holder (F276) x 6</p> <p>*These can also be round</p>

Ruler - Use this ruler to help correctly identify the screws



Assembly Instructions

If you have damaged or missing components, call the
Customer Helpline: 08456 400800 quoting the reference
numbers below

Step 1

Prepare the drawer fronts

Screw 2 metal dowels **B** into the holes shown on the back of each drawer front **8**.

Note: Tighten the metal dowels up fully against the panels.

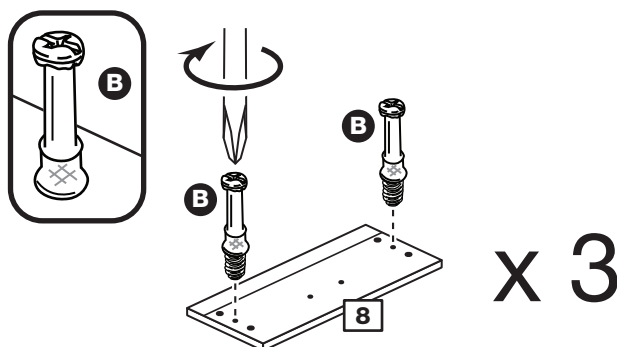

Step 2

Prepare the drawer sides

Insert a small locking nut **E** into the hole shown on the left drawer side **11** and right drawer side **12**.

Note: The arrow on the locking nut **must** point towards the hole in the edge of the panel.

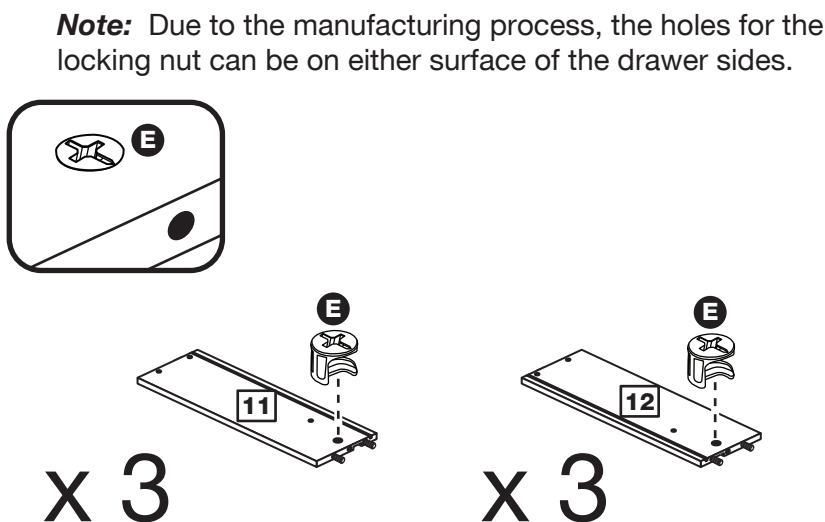

Step 3

Attach the drawer sides to the drawer fronts

Push the left drawer sides **11** and right drawer sides **12** onto the back of the 3 drawer fronts **8**.

Turn the small locking nuts **E** on the left drawer side **11** and right drawer side **12**.

Note: Turn the locking nuts **E** clockwise to secure panels - more than 1/2 a turn.

Note: The locking nuts can be on either surface of the drawer sides. Make sure that the small groove is on the inside, as shown.

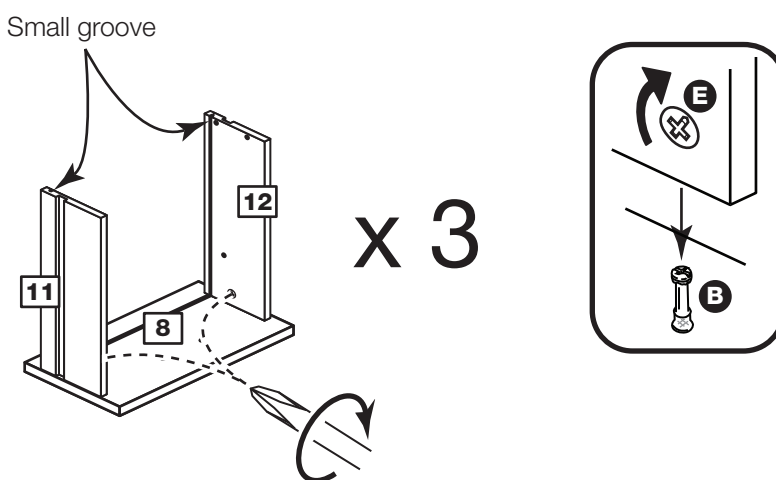

Assembly Instructions

Step 4

Fit the drawer base

Slide the drawer base **15** down the grooves in the drawer sides **11** and **12** and down into the groove in the small drawer front **8**.

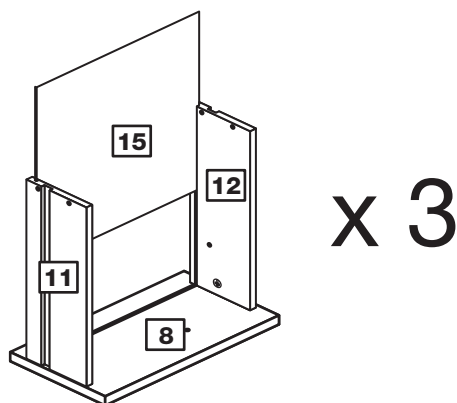

Step 5

Fit the drawer back

Fit the drawer back **14** between the drawer sides **11** and **12**.

Make sure that the drawer base **15** fits into the groove in the drawer back **14**.

Hold the drawer back **14** in position and tap the knock-in pegs **F** through the holes in the drawer sides **11** and **12**.

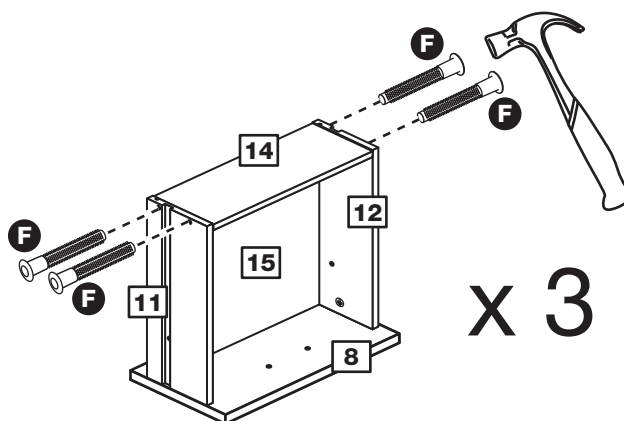

Step 6

Attach the handle

Attach a handle **P** to each drawer front **8** using 2 screws **H**.

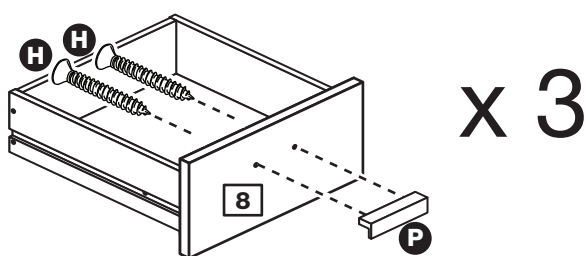

Step 7

Fit the wedgifixes

Turn the drawer assemblies over and slide 2 wedgifixes **V** into the front and back grooves, as shown, and tighten up the screws.

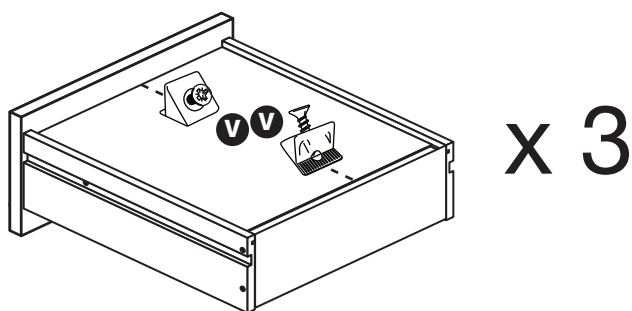
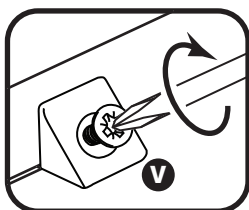

Assembly Instructions

Step 8

Prepare the long divider

a: Place 3 runners **Q** on the long divider **3**. Slide back the top of the runner and use the 1st hole from the front to fit the 1st screw **L**.

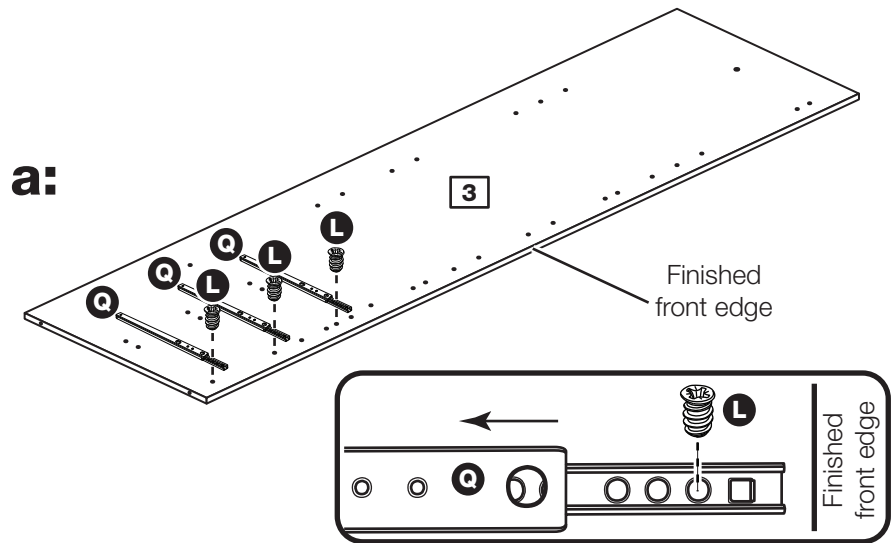

b: Slide the runner back the other way and use the 3rd hole from the back to fit the 2nd screw **L**.

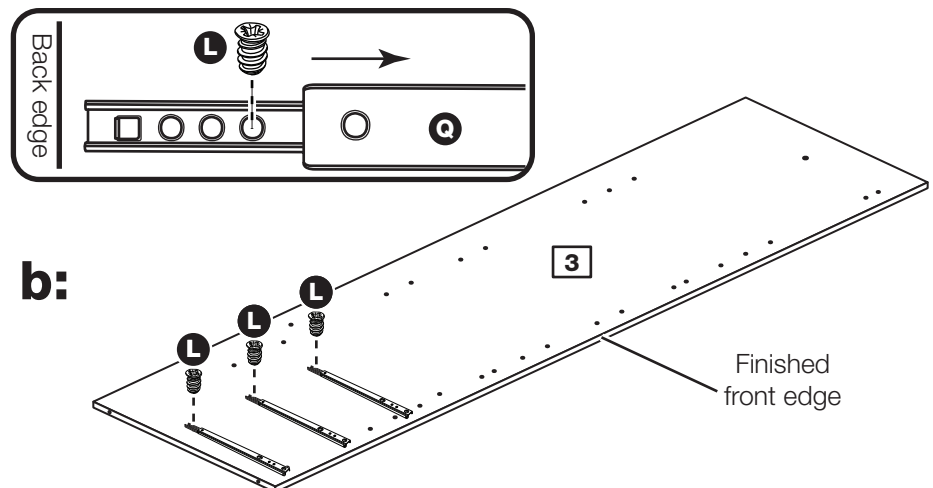

C: Important: The hinge plates **R** used in this step are in the bag marked as **AHP1043**.

Fit 3 hinge plates **R** onto the long divider **3**, making sure that the slot is facing towards the finished front edge.

Push a rail holder **N** into the long divider **3**. Make sure that it is fitted straight, in line with the panel edges.

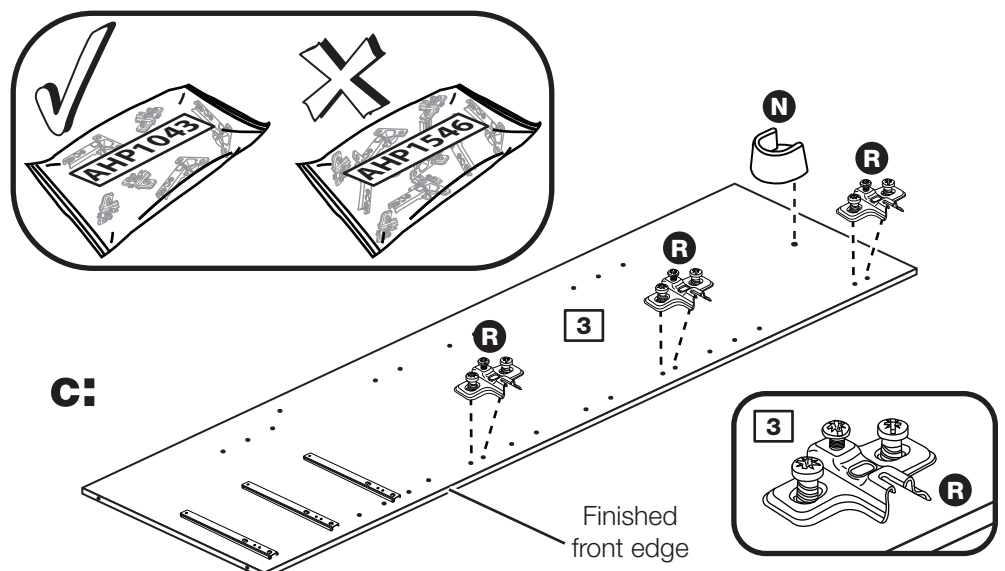

Assembly Instructions

Step 9

Join the long divider and fixed shelf

Attach the fixed shelf **7** to the long divider **3** using 2 screws **G**.

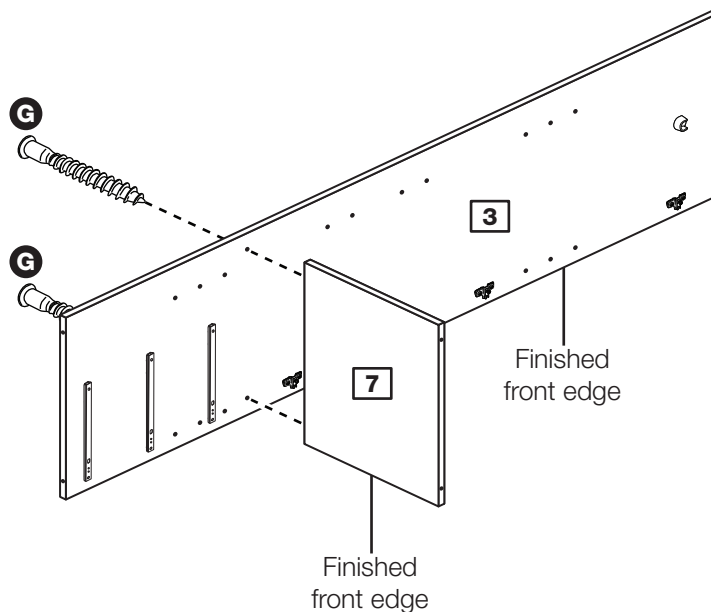

Step 10

Prepare the top and base

Tap 4 wooden dowels **A** into the top **4** and base **4** as shown.

Note: Wooden dowels **must not** stick out from the edge by more than 10mm or they may damage other panels.

Insert 4 large locking nuts **D** into the top **4** and base **4** as shown.

Note: The arrow on the locking nut **must** point towards the hole in the edge of the panel.

Important: If one of the top/base panels has a plain chipboard surface this must be used as the base.

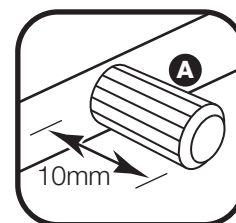
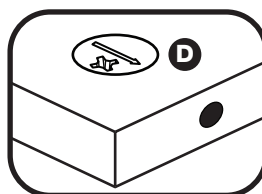
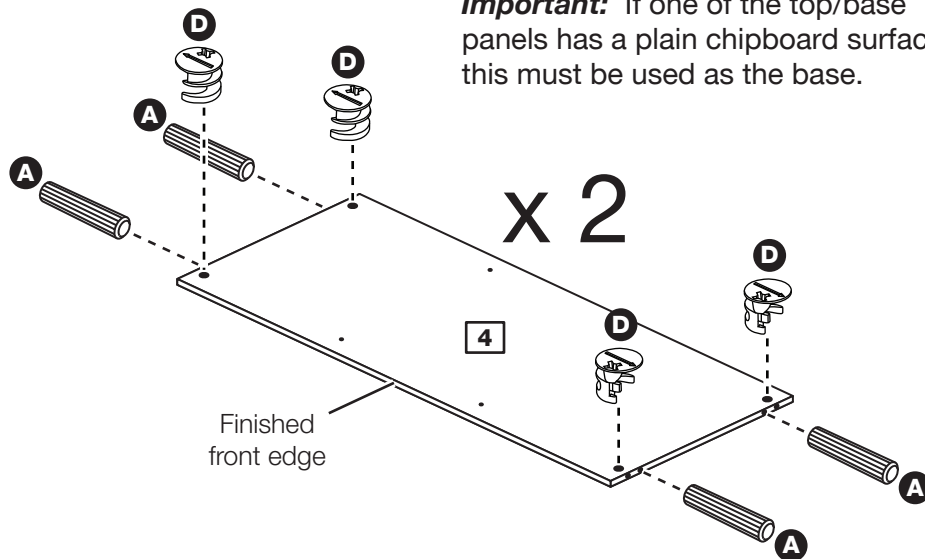

Assembly Instructions

Step 11

Fit top and base to the long divider

Attach the top **4** to the long divider **3** using 2 screws **G**.

Attach the base **4** to the long divider **3** using 2 screws **G**.

Important: If one of the top/base panels has a plain chipboard surface this must be used as the base.

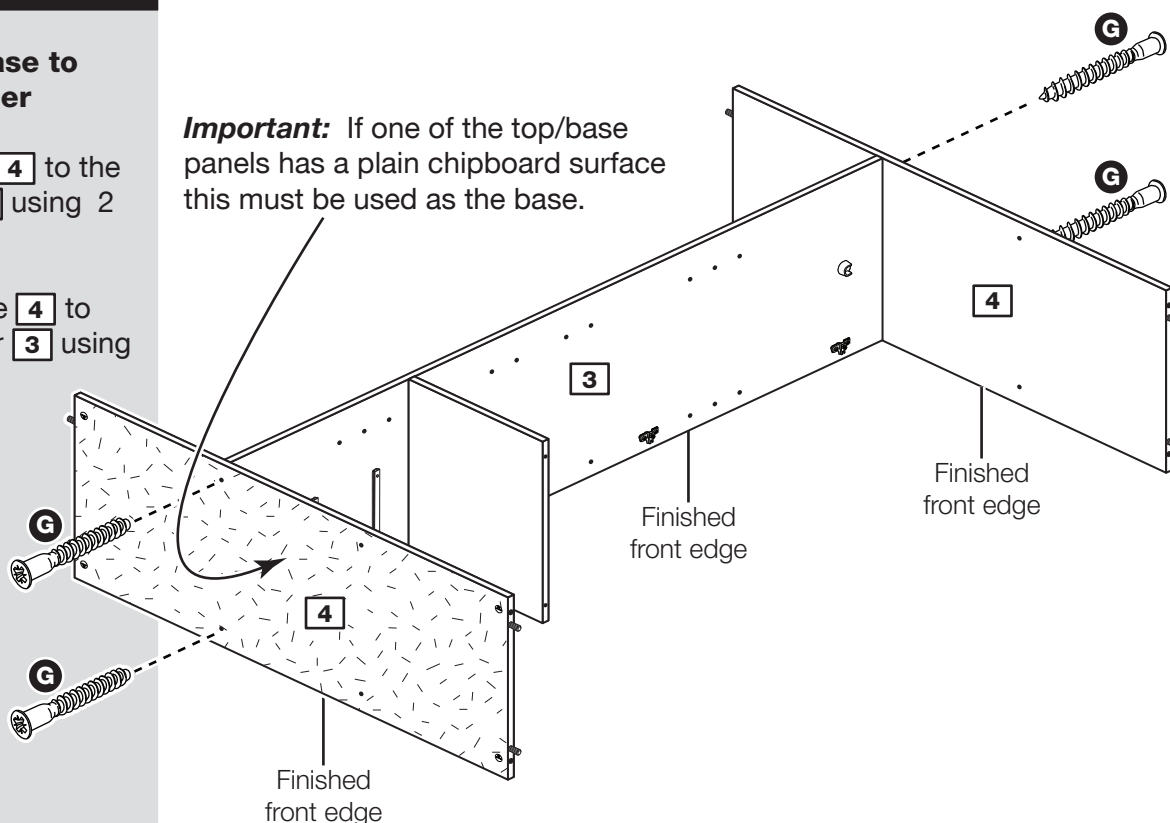

Step 12

Prepare the right side

Important: The hinge plates **T** used in this step are in the bag marked as **AHP1546**.

Fit 3 hinge plates **T** onto the right side **2**, making sure that the slot is facing towards the finished front edge.

Screw 5 metal dowels **B** into the right side **2**.

Note: Tighten the metal dowels up fully against the panels.

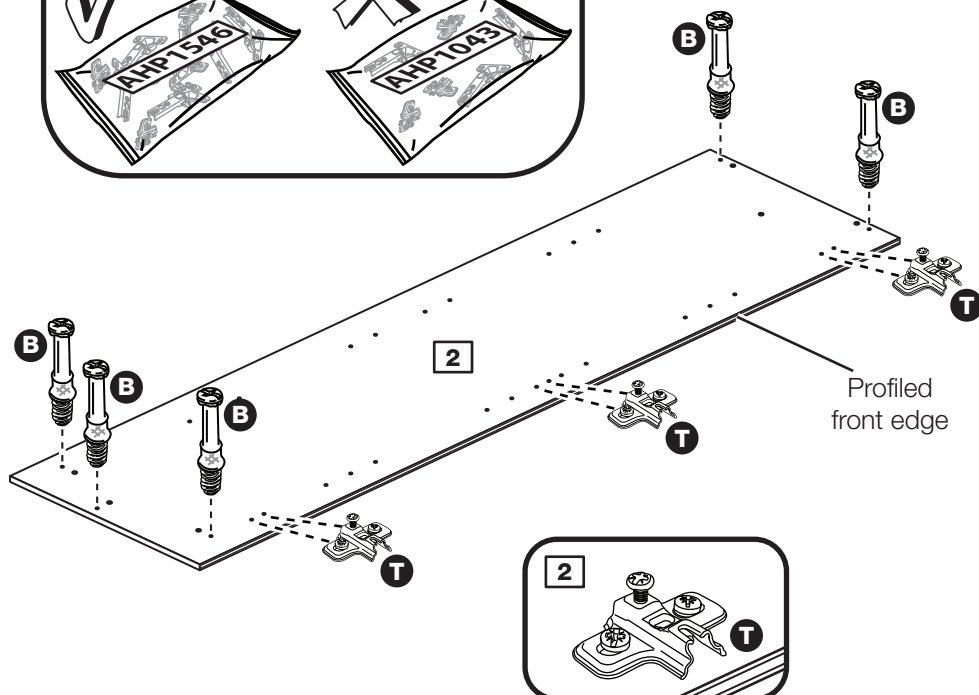
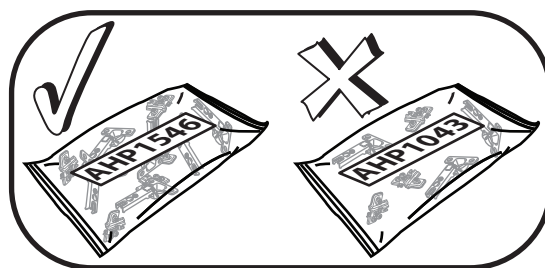

Assembly Instructions

Step 13

Fit the right side

Push the right side **2** onto the top **4** and base **4** as shown.

Use a screwdriver to tighten the 4 large locking nuts **D** fitted to the top **4** and base **4**.

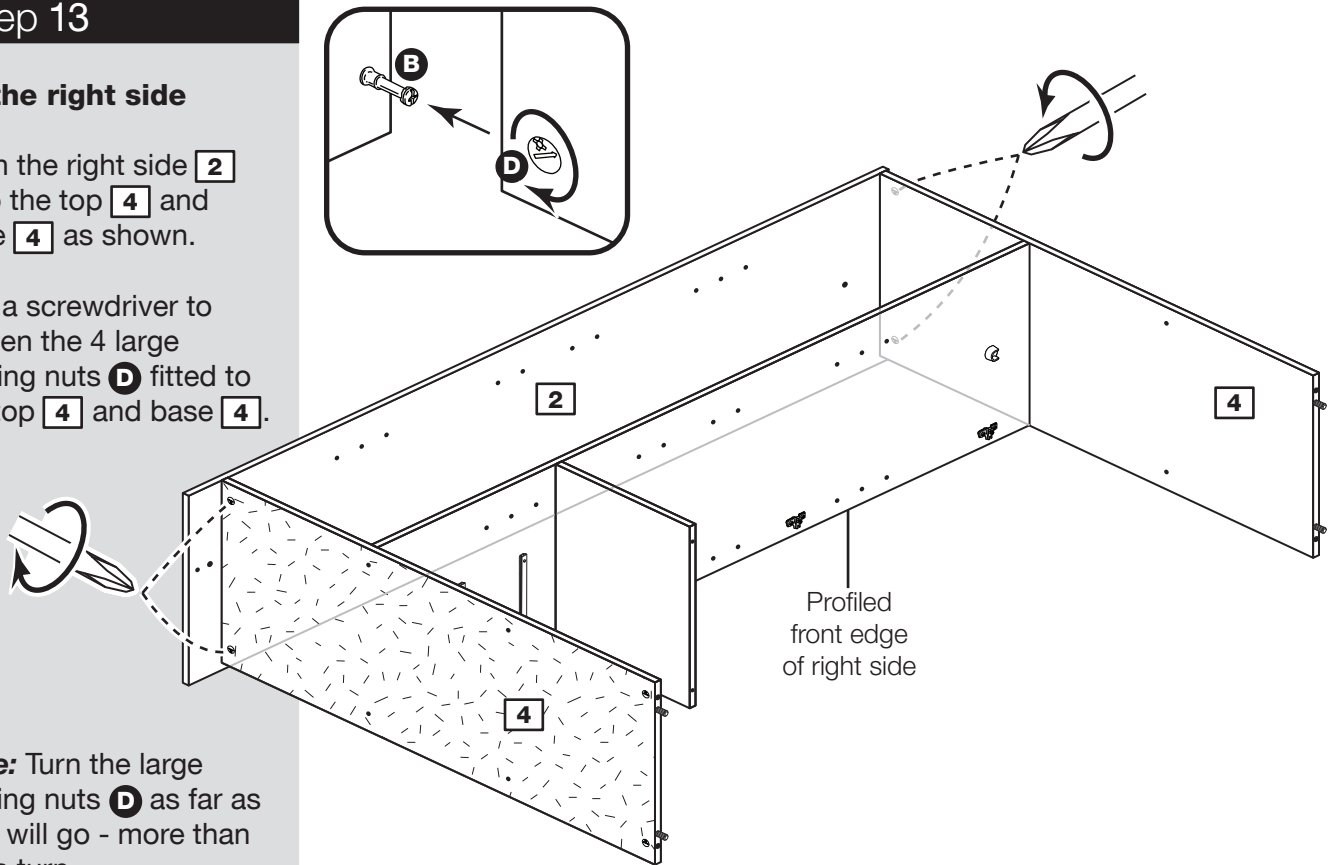

Note: Turn the large locking nuts **D** as far as they will go - more than 1/2 a turn.

Step 14

Fit runners to short divider

a: Place 3 runners **Q** on the short divider **6**. Slide back top of runner and use 1st hole from the front to fit 1st screw **L**.

b: Slide runner back the other way and use 3rd hole from the back to fit 2nd screw **L**.

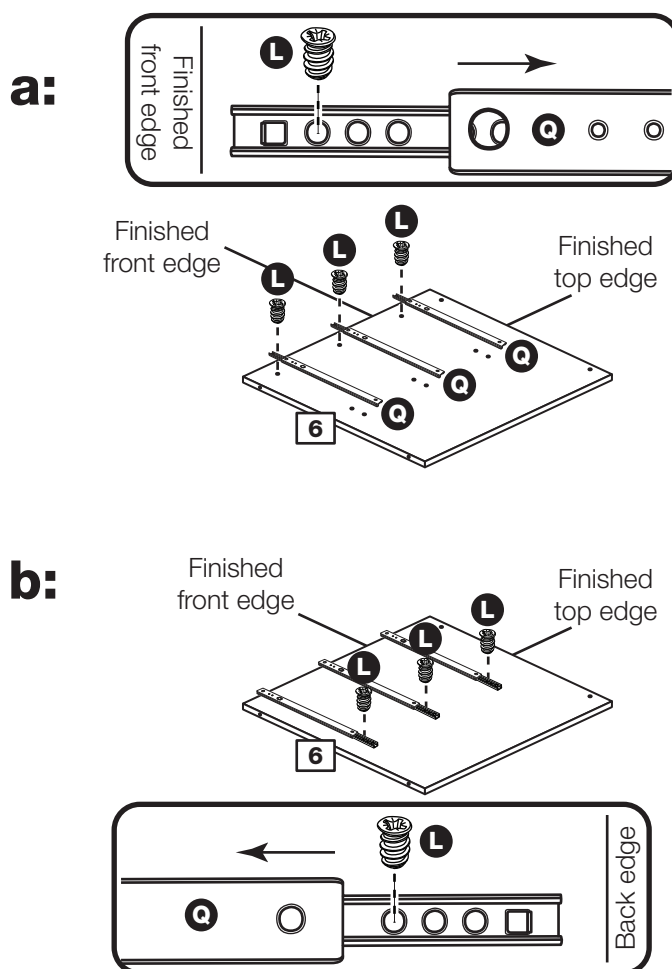

Assembly Instructions

Step 15

Fit the short divider

Attach the short divider **6** to the base **4** using 2 screws **G**.

Attach the short divider **6** to the fixed shelf **7** using 2 screws **G**.

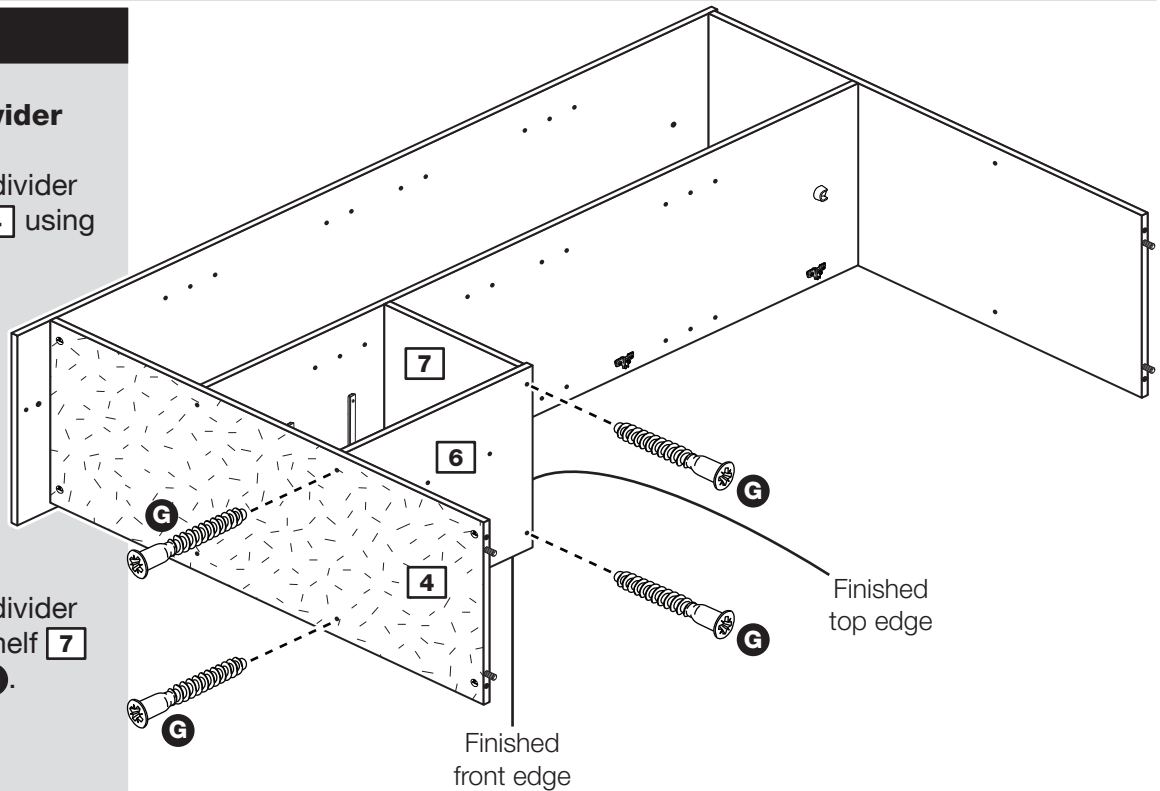

Step 16

Prepare the left side

Important: The hinge plates **T** used in this step are in the bag marked as **AHP1546**.

Fit 3 hinge plates **T** onto the left side **1**, making sure that the slot is facing towards the finished front edge.

Screw 5 metal dowels **B** into the left side **1**.

Note: Tighten the metal dowels up fully against the panels.

Push a rail holder **N** into the left side **1**. Make sure that it is fitted straight, in line with the panel edges.

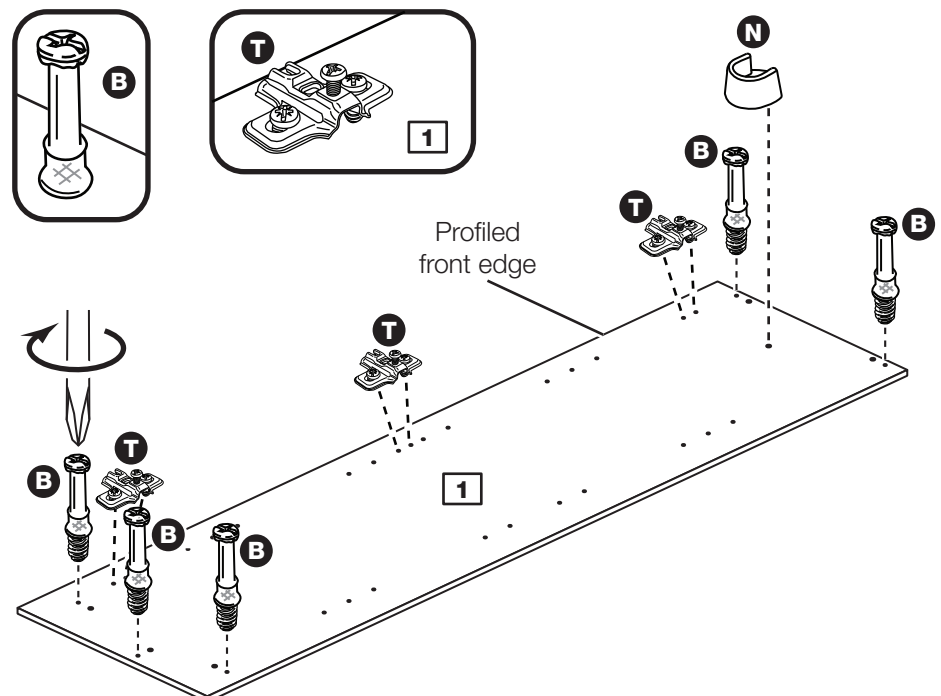
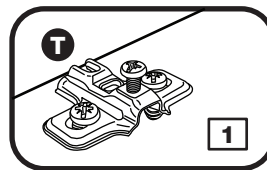
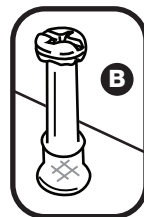
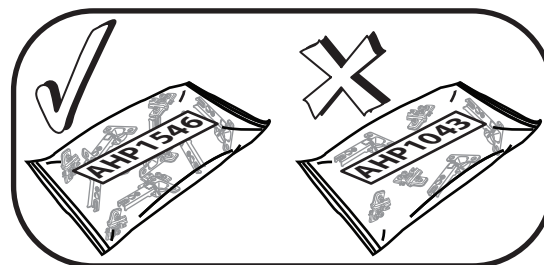

Assembly Instructions

Step 17

Prepare the plinth

Tap 2 wooden dowels **A** into the plinth **5**.

Insert 2 large locking nuts **D** into the plinth **5**.

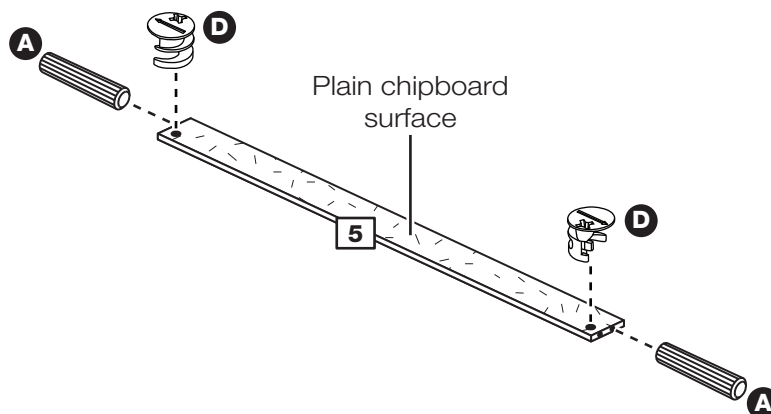

Step 18

Fit the plinth

Push the plinth **5** onto the right side **2**.

Use a screwdriver to tighten the large locking nut **D** fitted to the plinth **5**.

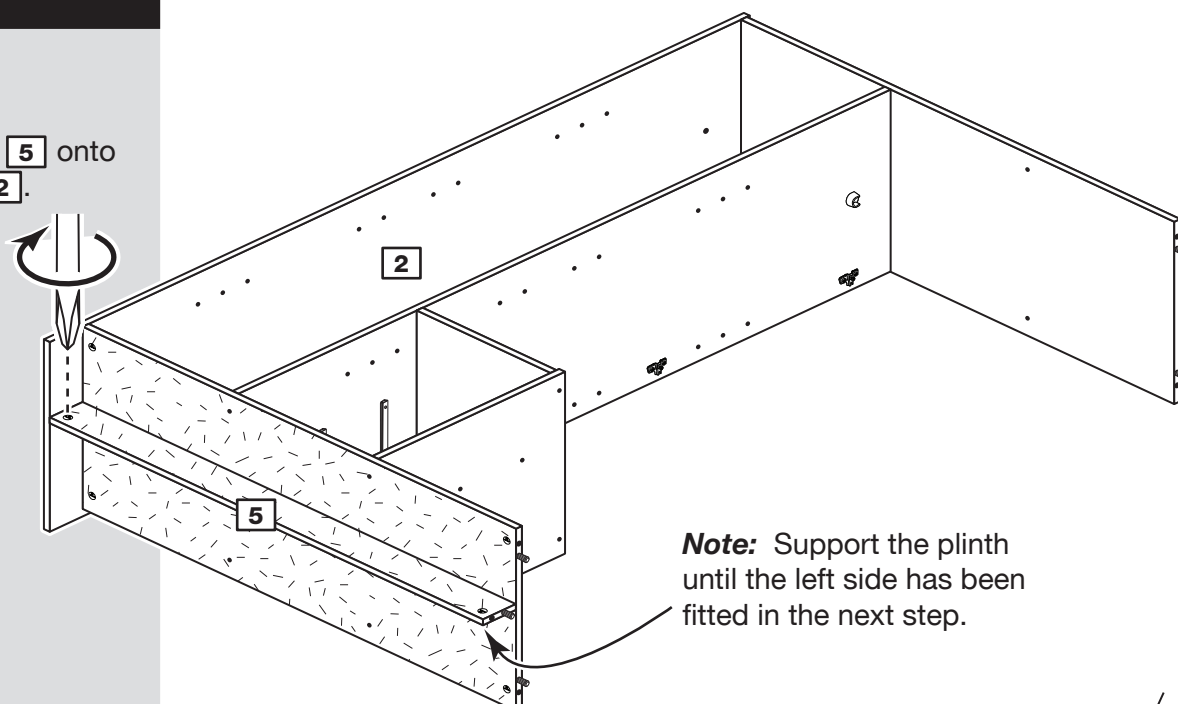

Step 19

Fit the left side

Push the left side **1** onto the top **4**, base **4** and plinth **5**.

Use a screwdriver to tighten the 5 large locking nuts **D** fitted to the top **4**, base **4** and plinth **5**.

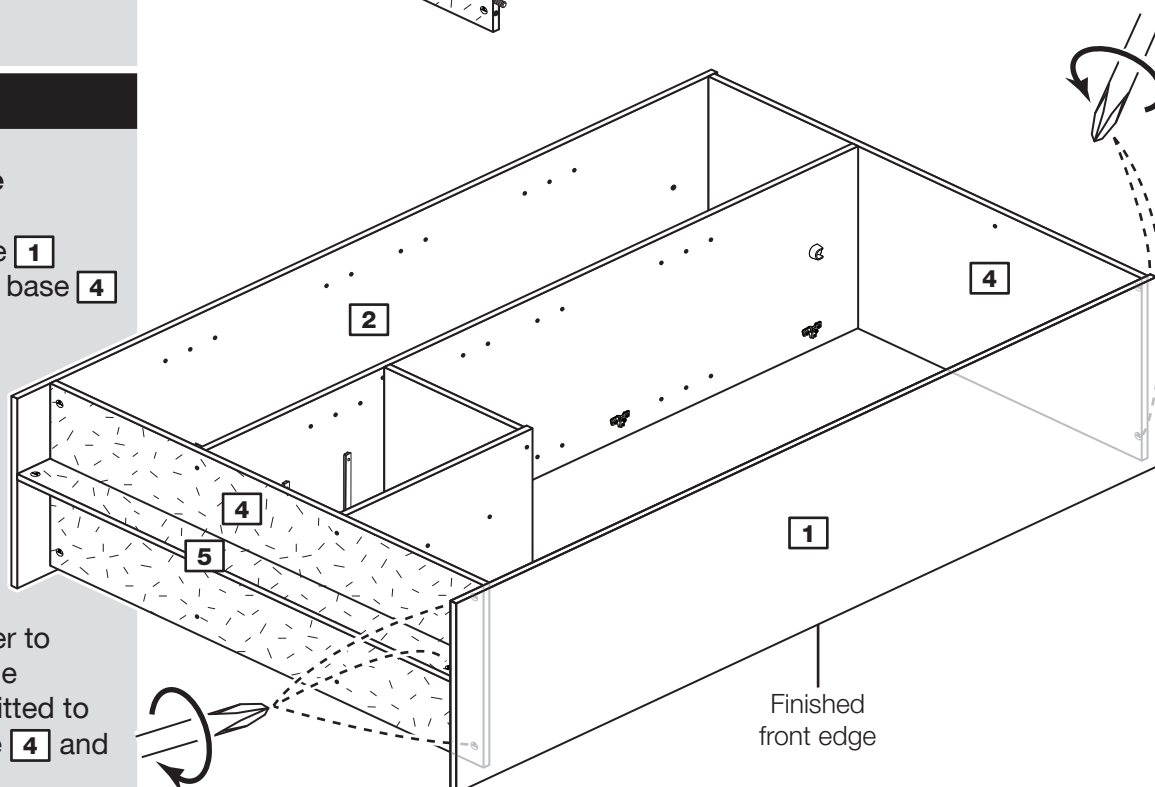

Assembly Instructions

Step 20

Fit the back panels

a: Square up the unit by making sure that measurement **x** to **x** equals **y** to **y**.

b: Place the small back **17** and large back **18** coloured surface facing down, onto the unit as shown. Make sure that the 2 backs **17** and **18** are pushed up tight against each other and that they meet in the centre of the long divider's **3** back edge.

Nail **c** around the outside edges of the 2 backs.

c: Push the 6 nail screws **x** through the 6 back holders **y** and tap them down between the 2 backs **17** and **18** and into the back edge of the centre divider **3**.

Keep tapping the nail screws **x** in until the back holders **y** dig into the backs.

d: Tap 2 plastic nails **w** into the bottom edge of each of the sides **1** and **2** and plinth **5**.

Stand the unit up for the next step.

a: The measurement from top corner X to bottom corner X must be equal to the measurement from top corner Y to bottom corner Y

Note: Do not nail where the 2 backs meet. Nails should be spaced out evenly.

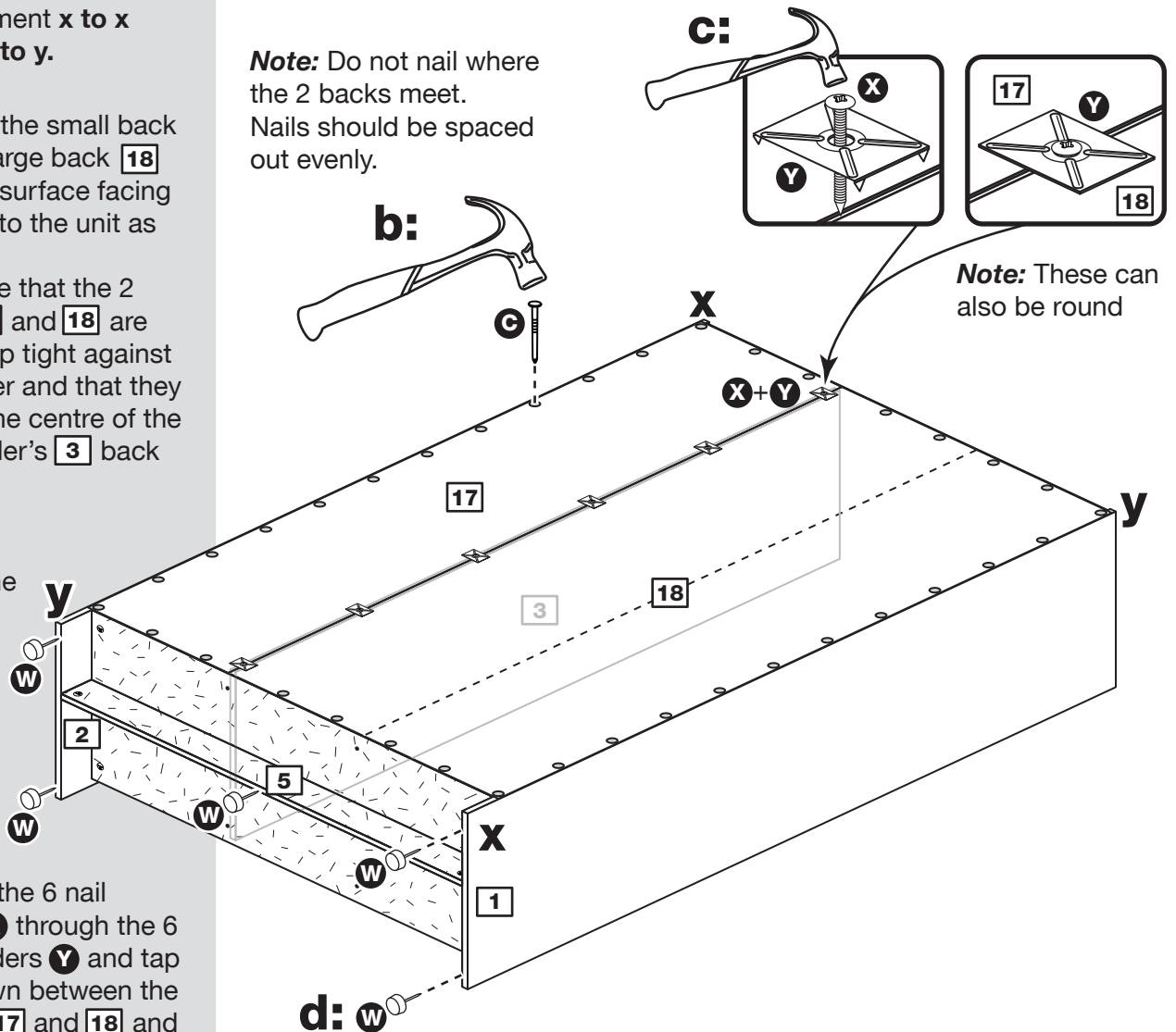

Warning: The unit is heavy. Lift with care.

Assembly Instructions

Step 21

Fit the hanging rail and drawers

Push the hanging rail **16** into the rail holders **N** fitted to the left side **1** and long divider **3**.

Starting with the bottom large drawer, slide both the runners **Q** forward and locate the drawer sides **11** and **12** between them, lining up the holes in the drawer wrap with the 2nd 'threaded' holes in the runners.

Working from the inside of the drawer, insert 2 screws **K** through the wrap and out into the 2nd threaded hole in the runner.

Note: Do not over-tighten the screws **K. If they catch on the runner you may need to loosen them slightly.**

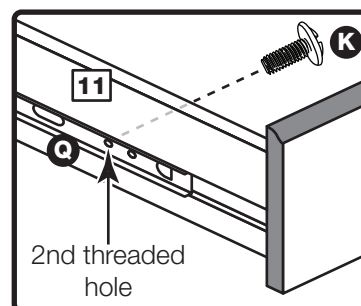
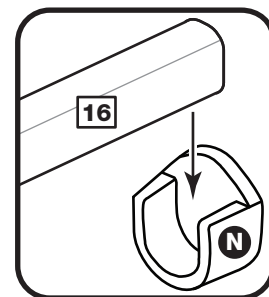
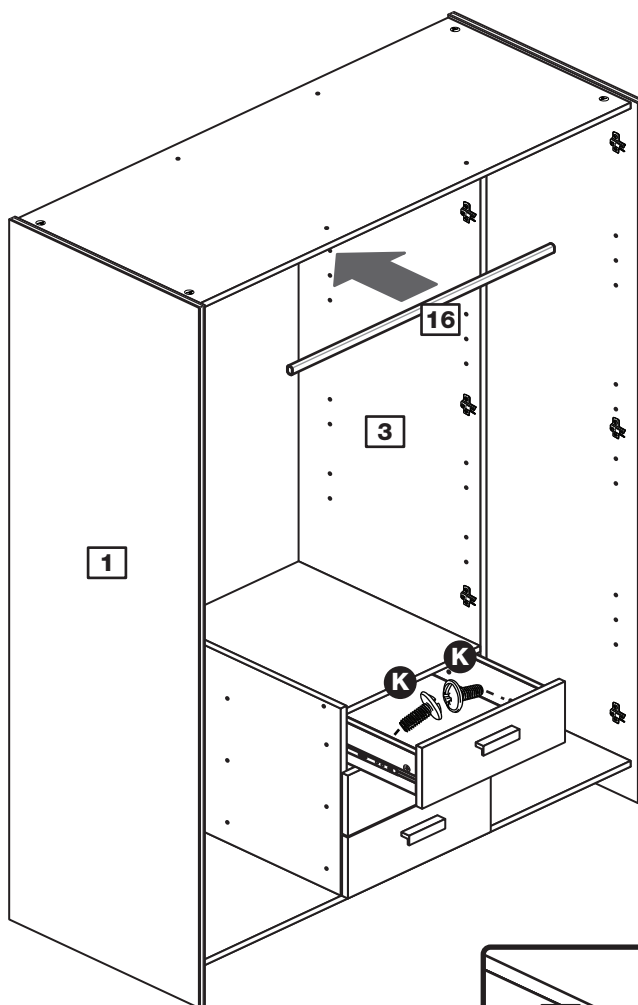

Assembly Instructions

Step 22

Fit the shelves

For each of the 3 shelves **13**, insert 4 shelf studs **M** at the required height.

Lower the 3 shelves **13** down onto the shelf studs **M**.

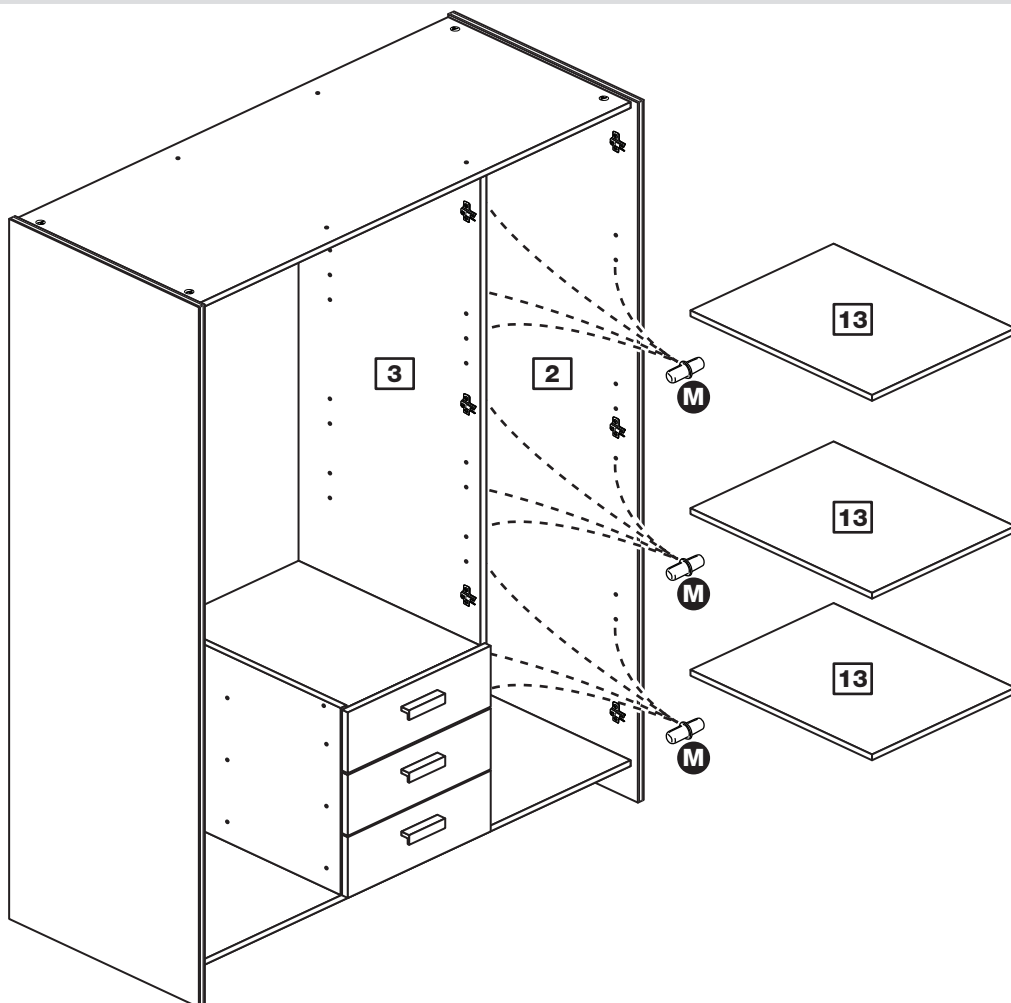

Step 23

Prepare the centre door

Important: The 3 hinges used in this step are in the bag marked as **AHP1043**.

Push fit 3 hinges **S** into the centre door **9**.

Secure each hinge with 2 screws **J**.

Note: Before securing with the screws, make sure that the hinges are positioned at 90 degrees with the edge of the door.

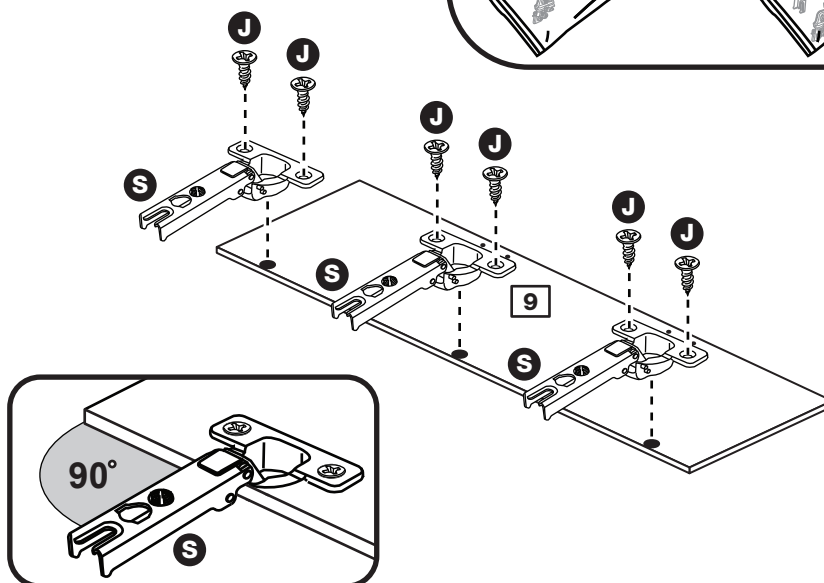
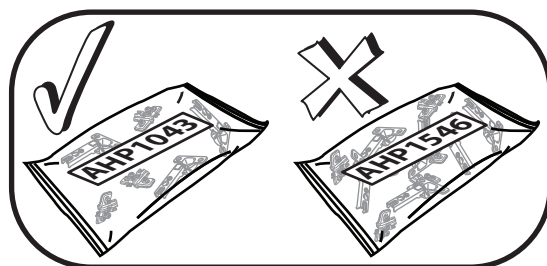

Assembly Instructions

Step 24

Drill the handle holes in the centre door

Important: Please follow these instructions carefully.

Lay the centre door **9** down onto a smooth surface.

Check that the hinges and holes are in the same place as the diagram.

Using the pilot holes in the rear face of the door, drill through the holes indicated opposite, using a 2.5mm diameter drill.

Turn the door over and open out the 2.5mm holes that you have just drilled by drilling back through them with a 5mm drill.

Carefully choose the 2 holes you need to drill

ONLY drill these 2 holes in the centre door

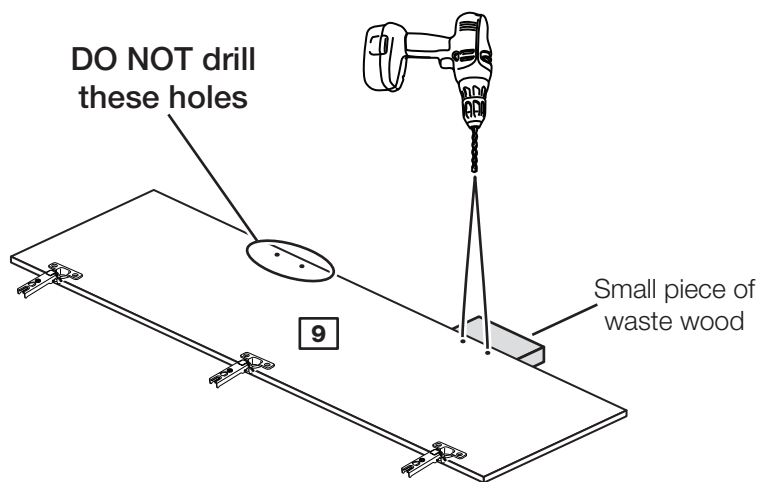

Note: We recommend the use of a small piece of waste wood, placed behind the hole while drilling, to reduce the possibility of any breakout.

Step 25

Prepare the outer doors

Important: The 6 hinges used in this step are in the bag marked as **AHP1546**.

Push fit 3 hinges **U** into each outer door **10**.

Secure each hinge with 2 screws **J**.

Note: Before securing with the screws, make sure that the hinges are positioned at 90 degrees with the edge of the door.

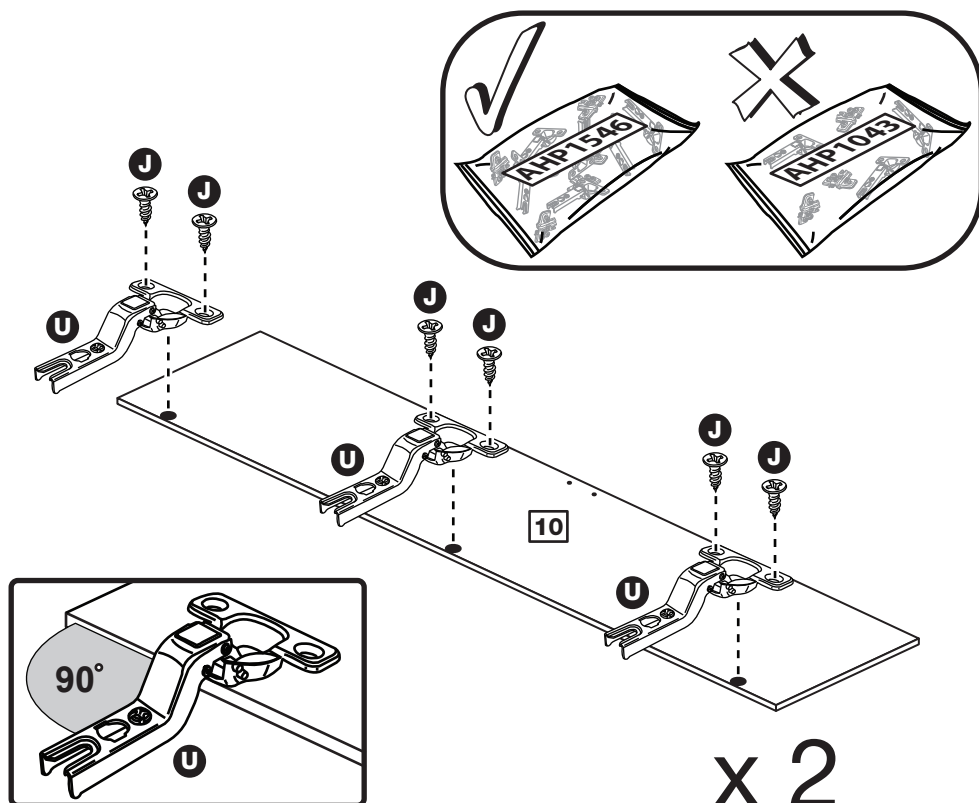

Assembly Instructions

Step 26

Fit the outer doors and handles

Note: The easiest way to attach each door **10** is to fit the top hinge first, then align and fit the other hinges.

a: Push the hinge **U** onto the front part of the hinge plate **T**.
The recess at the bottom of screw B goes into the slot in the hinge plate.

b: Keep the hinge **U** FLAT against the hinge plate **T** as you slide it across as far as it will go. Tighten screw A.

c: The hinge **U** must be flat against the hinge plate **T** prior to any adjustment.

d: The hinge **U** must NOT be AT AN ANGLE to the hinge plate **T** when assembled. This would indicate that the recess at the bottom of screw B had not located in the slot in the hinge plate and the hinge would not be secure. Remove the hinge from the hinge plate and then re-assemble being careful to follow instructions a-c.

e: Attach a handle **P** to each outer door **10** using 2 screws **H**.

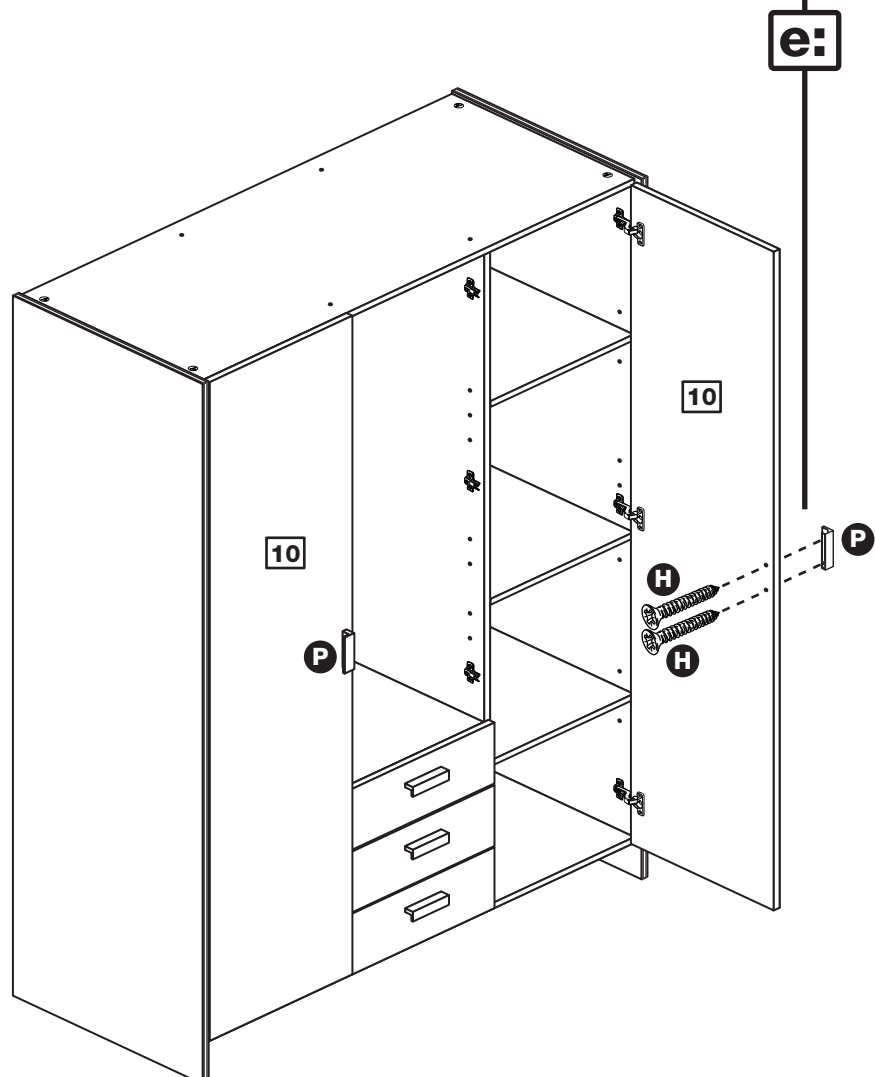
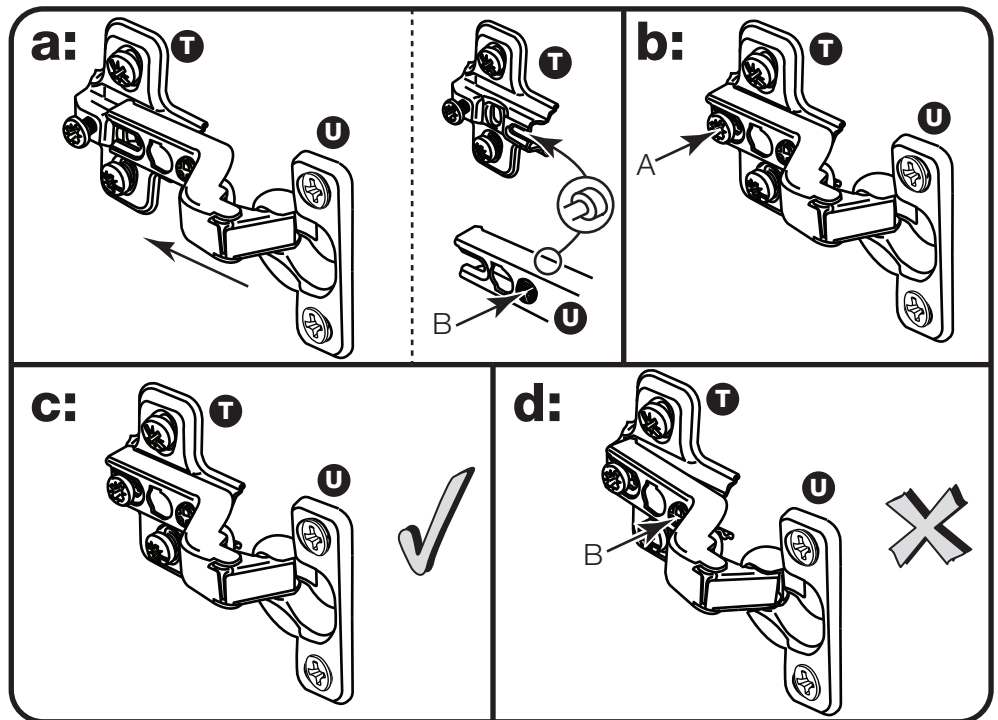

Assembly Instructions

Step 27

Fit the centre door and handle

Note: The easiest way to attach the centre door **9** is to fit the top hinge first, then align and fit the other hinges.

a: Push the hinge **S** onto the front part of the hinge plate **R**. The recess at the bottom of screw B goes into the slot in the hinge plate.

b: Keep the hinge **S** FLAT against the hinge plate **R** as you slide it across as far as it will go. Tighten screw A.

c: The hinge **S** must be flat against the hinge plate **R** prior to any adjustment.

d: The hinge **S** must NOT be AT AN ANGLE to the hinge plate **R** when assembled. This would indicate that the recess at the bottom of screw B had not located in the slot in the hinge plate and the hinge would not be secure. Remove the hinge from the hinge plate and then re-assemble being careful to follow instructions a-c.

e: Attach a handle **P** to the centre door **9** using 2 screws **H**.

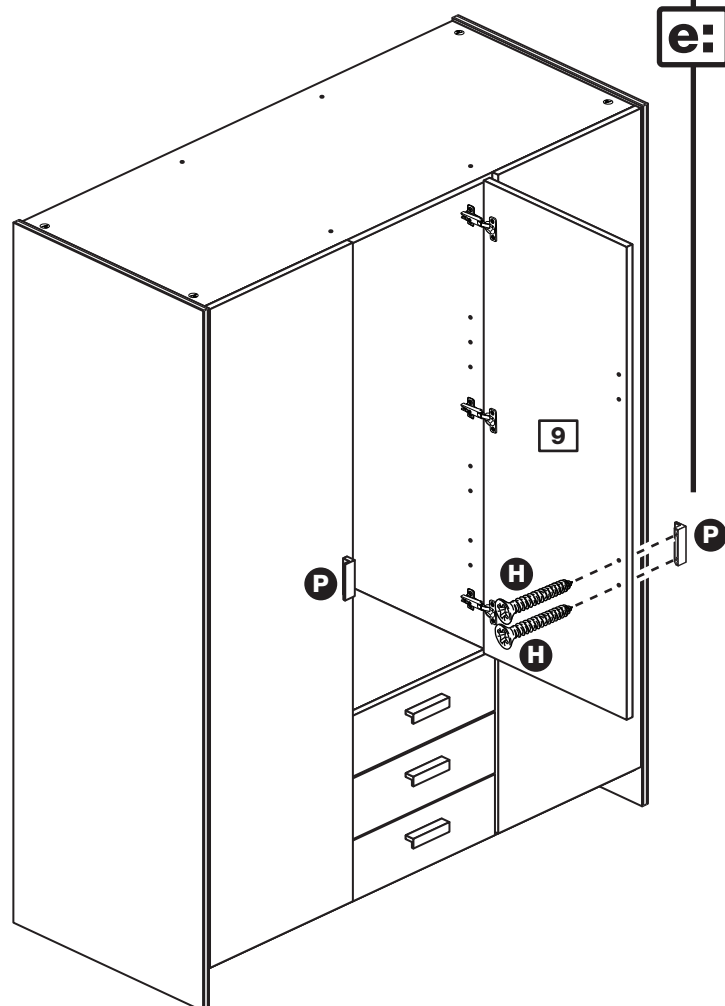
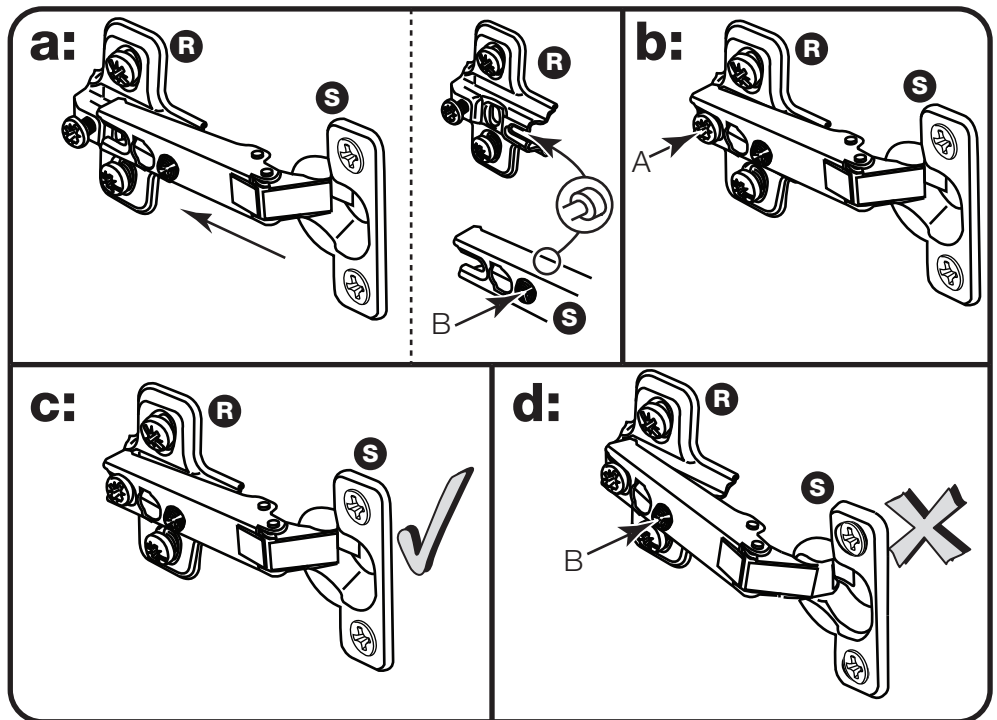

Assembly Instructions

Step 28

Adjust the doors if needed

a: Before adjusting the doors, use a spirit level to check the base (or top) of the unit is level, front-to-back and side-to-side in the 3 positions shown. Use suitable packing pieces (not supplied) to make the unit level BEFORE making any adjustment to the hinges, as shown.

b: Height adjustment.

Loosen screws A on hinge plates and move door up or down as required. Retighten screw A.

c: Forward and Back adjustment.

Loosen screw B on hinge plate and move door in or out as required. Retighten screw B.

d: Sideways adjustment.

To move door 'out' loosen screw C. To move door 'in' tighten screw C.

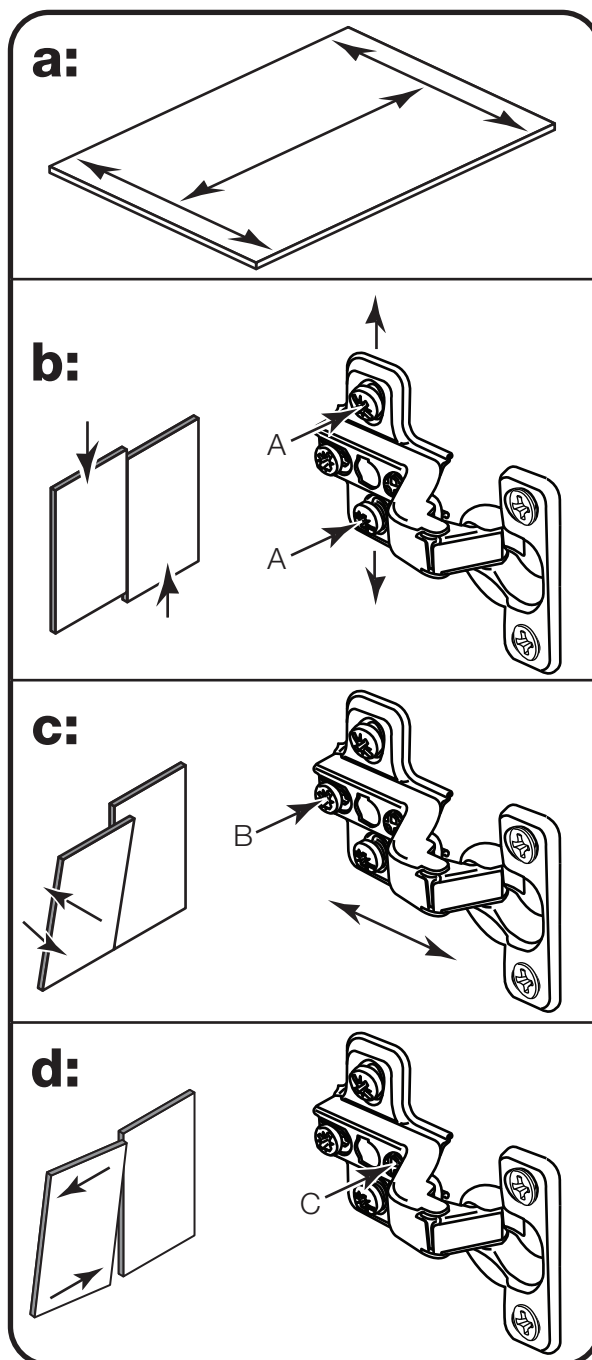

This shows the hinge and plate that is fitted to the outer doors. The ones fitted to the centre door are adjusted in the same way.

Assembly Instructions

Step 29

Fit the bracket

To prevent possible overbalancing, we recommend that this unit is secured to a suitable wall by use of the bracket **⓪** fitted to the top of the unit.

Fixings are not supplied, as they will need to suit the wall type and the length of screw will depend on the distance from the back of the unit to the wall.

Fix the bracket **⓪** loosely onto the top of the unit using screw **Ⓛ** and mark the wall for the wall fixing.

Swivel the bracket **⓪** away from the wall and drill a hole in the wall using a suitable drill bit and fit your wall fixing.

Swivel the bracket **⓪** back and fix the bracket to the wall, then tighten Screw **Ⓛ**.

Note: Take care when drilling the wall that you do not drill into any pipes, wires etc. If in doubt, consult an expert.



Warning: The unit is heavy. Lift with care.

Assembly is complete

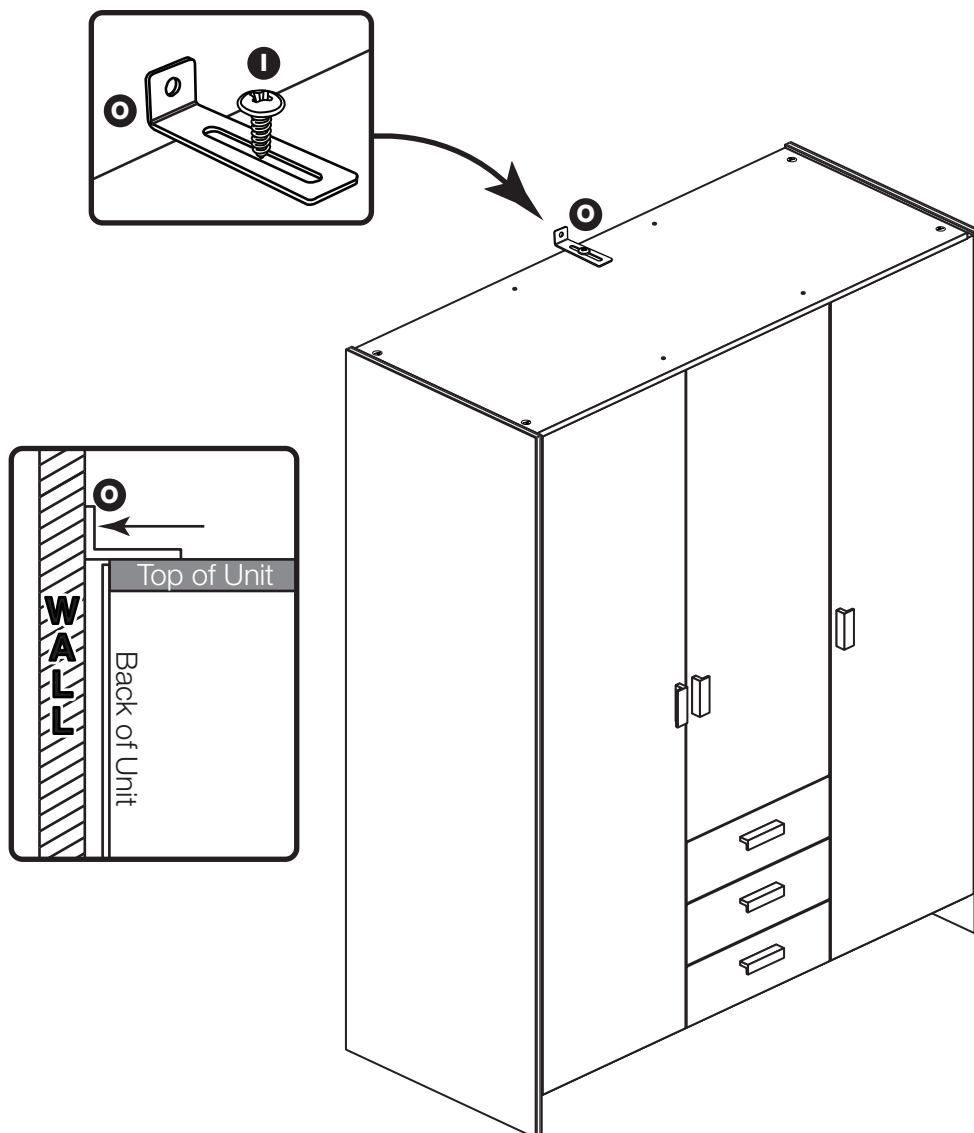

If you need help or have damaged or missing parts, call the Customer Helpline: 08456 400800 and quote the reference numbers on the component pages.

Argos Ltd, 489-499 Avebury Boulevard, Central Milton Keynes, MK9 2NW