



User's Guide

Digital Audio Baby Monitor

Model: MBP9

The features described in this User's Guide are subject to modifications without prior notice.

Welcome...

to your new Digital Audio Baby Monitor!

Thank you for purchasing the MBP9. This baby monitor uses digital communication which ensures that you can hear your baby clearly without any distracting noise or interference.

Please retain your original dated sales receipt for your records. For warranty service of your Motorola product, you will need to provide a copy of your dated sales receipt to confirm warranty status. Registration is not required for warranty coverage.

For product related questions, please call:

UK 0845 218 0890
ROI 08187 62092

This User's Guide provides you with all the information you need to get the most from your product.

Before you can use the baby monitor, you'll need to insert and fully charge the batteries on the Parent unit. Please read the Safety Instructions in section 1 "Safety Instructions" before you install the units.

Got everything?

- 1 x Parent unit
- 1 x Baby unit
- 1 x Rechargeable battery pack for the Parent unit
- 1 x Power adapter for the Parent unit
- 1 x Power adapter for the Baby unit

Overview of your Parent unit

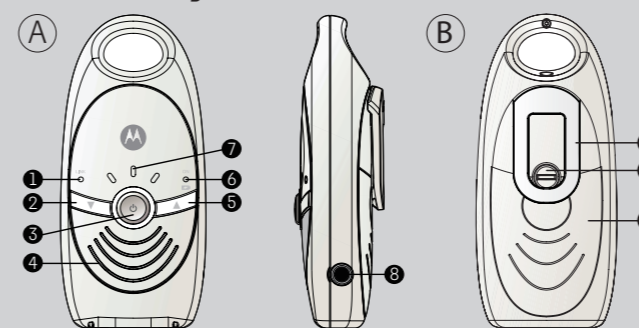

1. Link indicator LED
2. Volume down button
3. Power On/Off button
4. Speaker
5. Volume UP button
6. Power (ON /) LED
7. Volume indicator LEDs
8. Power adapter connector
9. Belt clip
10. Battery cover screw
11. Battery cover

Overview of your Baby unit

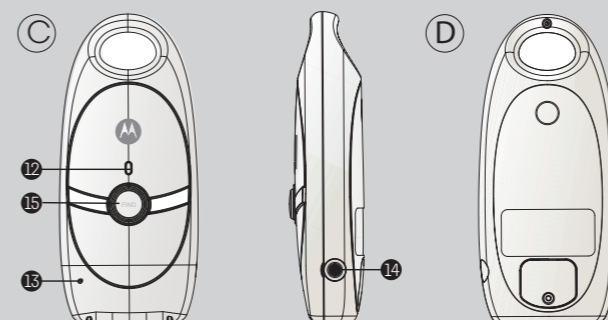

12. Power LED
13. Microphone
14. Power adapter connector
15. FIND key

Table of contents

1. Safety Instructions	5
2. Getting started	6
2.1 Baby unit power supply	6
2.2 Parent unit battery installation	7
2.3 Parent unit power supply	8
2.4 Link	9
2.5 Paging	9
3. Using the MBP9	9
3.1 Volume adjustment on the Parent unit	9
4. Disposal of the device (environment)	10
5. Cleaning	10
6. Help	10
7. General Information	11

1. Safety Instructions



WARNING:

STRANGULATION HAZARD - Keep the Unit and adapter cords more than 1 metre from the cot and out of baby's reach. NEVER place the Unit or cords within the cot. SECURE the cords more than 1 metre away from baby's reach. Never use extension cords with AC Adapters. Only use the AC Adapters provided.

BABY UNIT SET UP & USE:

- Determine a location for the BABY UNIT that will provide the best view of your baby in his/her cot.
- Place the BABY UNIT on a flat surface, such as a dresser, bureau, or shelf or mount the Unit to a wall securely using the keyhole slots under the stand.
- NEVER place the baby unit or cords within the cot.

WARNING

This Digital Audio Baby Monitor is compliant with all relevant standards regarding electromagnetic fields and is, when handled as described in the User's Guide, safe to use. Therefore, always read the instructions in this User's Guide carefully before using the device.

- Adult assembly is required. Keep small parts away from children when assembling.
- This product is not a toy. Do not allow children to play with it.
- This Baby Monitor is not a substitute for responsible adult supervision.
- Keep this user's guide for future reference.
- Keep the cords out of reach of children.
- Do not cover the Baby Monitor with a towel or blanket.

- Test this monitor and all its functions so that you are familiar with it prior to actual use.
- Do not use the Baby Monitor in damp areas or close to water.
- Do not install the Baby Monitor in extreme cold or heat, direct sunlight, or close to a heat source.
- Only use the chargers and power adapters provided. Do not use other chargers or power adapters as this may damage the device and battery pack.
- Only insert a battery pack of the same type.
- Do not touch the plug contacts with sharp or metal objects.
- Connect the power adapters to easily accessible electrical outlets.

CAUTION

You chance the risk of explosion if battery is replaced by an incorrect type. Dispose of used batteries according to their instructions.

2. Getting started

2.1 Baby unit power supply

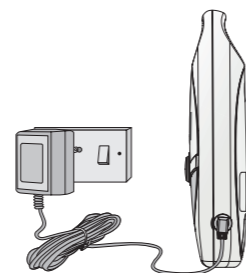

- 2.1.1 Connect the small plug of the power adapter to the power connector on the baby unit and the other end of the adapter to the mains socket (100-240Vac-50/60Hz).

NOTE

Only use the enclosed power adapter (5V DC /600mA).

2.2 Parent unit battery installation

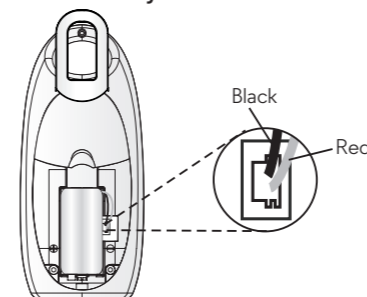

The Parent unit can be used with either the rechargeable battery pack (2.4V 600mAh Ni-MH rechargeable battery pack supplied) or via the power adapter supplied.

WARNING

Never use ordinary, non-rechargeable batteries. The power mains adapter provides a charging function, and non-rechargeable batteries may burst and cause damage!

NOTE

The Ni-MH rechargeable batteries must be charged for 16 hours before using the Parent unit without the mains power.

We recommend the rechargeable batteries are installed, so that the unit continues to work in the event of a mains power failure.

1. Using a screwdriver, turn the screw of the battery cover on the back of the parent unit 90 degrees in a counterclockwise direction. Remove the battery cover.

NOTE

Rotate the belt clip to its hanging position to make it easier to access the battery compartment.

Do not try to turn the screw further than the OPEN position marked on the cover.

2. Insert one battery pack with 2 AAA size Ni-MH rechargeable batteries.
3. Close the battery compartment and turn the screw 90 degrees back in a clockwise direction.
4. Press and hold . The Power (ON /) LED will illuminate red if it only has battery power.
5. Press and hold to switch off the parent unit.

NOTE

When the battery level is low, the red power LED will flash and the parent unit will emit a warning beep once every minute. If the baby unit loses power or goes out of range, the link will be lost and the parent unit will emit a warning beep every 20 seconds and the green link LED on the parent unit will continue to flash.

WARNING

Keep batteries away from small children. Do not short-circuit batteries or dispose of in fire. Remove the batteries if this device is not going to be used for a long period of time.

2.3 Parent unit power supply

1. Connect the small plug of the power adapter to the power connector on the parent unit and the other end of the adapter to the mains socket (100V-240V ~ 50/60Hz).

NOTE

Only use the enclosed adapter (5V DC/600mA).

2. Press and hold . The Power (ON /) LED will illuminate red if it only has mains power.
3. Press and hold to switch off the parent unit.

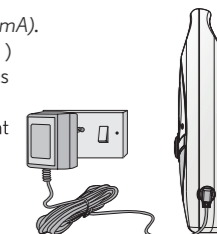

2.4 Link

NOTE

Do not place the baby unit or cables in the cot or within arm's reach of the baby (the unit should be at least 1 metre away).

When using the baby monitor for the first time, it is advised to test the connection.

- Install the parent unit in the same room as the baby unit, but make sure there is at least 1 metre between the 2 units.
- When both units are switched on, the parent unit will search for the baby unit.
- The green link LED on the parent unit will flash until the parent unit is connected with the baby unit. Once the link is established, the LED will stop flashing.
- The sound captured by the microphone on the baby unit will be audible on the parent unit.
- The detected sound level is indicated by the LEDs on the front of the parent unit.
- When the connection is established, move the parent unit to the room you want to monitor from, but within the operational range.
- When there is no connection or out of range, the parent unit emits a warning beep every 20 seconds and the green link LED on the parent unit will flash.
- Move the parent unit closer until the link is re-established.



2.5 Paging

If the parent unit is misplaced, press FIND key on Baby unit. The parent unit will emit a repeated beep tone for 30 seconds so that you can locate it. Press any key on the parent unit, or the  again on the Baby unit, to stop paging.

3. Using the MBP9



3.1 Volume adjustment on the Parent unit

There are 5 volume levels on the parent unit.

- Press  to increase the volume level.
- Press  to decrease the volume level.

9

NOTE

When you press  or  a beep is played at the volume level currently set, but if you try to adjust beyond the maximum or minimum levels it will output a double beep.

4. Disposal of the device (environment)

At the end of the product lifecycle, you should not dispose of this product with normal household waste, but take the product to a collection point for the recycling of electrical and electronic equipment. The symbol on the product, User's Guide and/or box indicates this.

Some of the product materials can be re-used if you take them to a recycling point. By reusing some parts or raw materials from used products you make an important contribution to the protection of the environment. Please contact your local authorities in case you need more information on the collection points in your area. Dispose of the batteries in an environmentally-friendly manner according to your local regulations.



5. Cleaning

Clean the MBP9 with a slightly damp cloth or with an anti-static cloth. Never use cleaning agents or abrasive solvents.

Cleaning and care

- Do not clean any part of the product with thinners or other solvents and chemicals – this may cause permanent damage to the product which is not covered by the warranty. When necessary, clean it with a damp cloth.
- Keep your MBP9 away from hot, humid areas or strong sunlight, and do not let it get wet.
- Every effort has been made to ensure high standards of reliability for your MBP9. However, if something does go wrong, please do not try to repair it yourself – contact Customer Service for assistance.

6. Help

If the baby unit has lost its link with the parent unit

- Try recharging or replacing the batteries.

10

- If the baby unit is too far away it may be going out of range, so move the baby unit closer to the parent unit.
- Reset the units by unplugging the units' electrical power. Wait for around 15 seconds and plug it back in again. Allow up to one minute for the baby unit and the parent unit to synchronise.

Interference

Noise interference on your parent unit

- Your baby and parent units may be too close. Move them further away from each other.
- Make sure there is at least 1 metre between the 2 units to avoid feedback howling.
- If the baby unit is too far away it may be going out of range, so move the baby unit closer to the parent unit.
- Make sure the baby and parent units are not near other electrical equipment, such as a television, computer or cordless/mobile telephone.

7. General Information

If your product is not working properly....

1. Read this User's Guide.
2. Visit our website: www.motorola.com

3. Contact Customer Service at:
UK 0845 218 0890
ROI 08187 62092

To order replacement battery pack for parent unit, contact customer service.

Consumer Products and Accessories Limited Warranty ("Warranty")

Thank you for purchasing this Motorola branded product manufactured under license by Binatone Electronics International LTD ("BINATONE")

What Does this Warranty Cover?

Subject to the exclusions contained below, BINATONE warrants that this Motorola branded product ("Product") or certified accessory ("Accessory") sold

11

for use with this product that it manufactured to be free from defects in materials and workmanship under normal consumer usage for the period outlined below. This Warranty is your exclusive warranty and is not transferable.

Who is covered?

This Warranty extends only to the first consumer purchaser, and is not transferable.

What will BINATONE do?

BINATONE or its authorized distributor at its option and within a commercially reasonable time, will at no charge repair or replace any Products or Accessories that does not conform to this Warranty. We may use functionally equivalent reconditioned/ refurbished/ pre-owned or new Products, Accessories or parts.

What Other Limitations Are There?

ANY IMPLIED WARRANTIES, INCLUDING WITHOUT LIMITATION THE IMPLIED WARRANTIES OF MERCHANTABILITY AND FITNESS FOR A PARTICULAR PURPOSE, SHALL BE LIMITED TO THE DURATION OF THIS LIMITED WARRANTY, OTHERWISE THE REPAIR OR REPLACEMENT PROVIDED UNDER THIS EXPRESS LIMITED WARRANTY IS THE EXCLUSIVE REMEDY OF THE CONSUMER, AND IS PROVIDED IN LIEU OF ALL OTHER WARRANTIES, EXPRESS OF IMPLIED. IN NO EVENT SHALL MOTOROLA OR BINATONE BE LIABLE, WHETHER IN CONTRACT OR TORT (INCLUDING NEGLIGENCE) FOR DAMAGES IN EXCESS OF THE PURCHASE PRICE OF THE PRODUCT OR ACCESSORY, OR FOR ANY INDIRECT, INCIDENTAL, SPECIAL OR CONSEQUENTIAL DAMAGES OF ANY KIND, OR LOSS OF REVENUE OR PROFITS, LOSS OF BUSINESS, LOSS OF INFORMATION OR OTHER FINANCIAL LOSS ARISING OUT OF OR IN CONNECTION WITH THE ABILITY OR INABILITY TO USE THE PRODUCTS OR ACCESSORIES TO THE FULL EXTENT THESE DAMAGES MAY BE DISCLAIMED BY LAW.

Some jurisdictions do not allow the limitation or exclusion of incidental or consequential damages, or limitation on the length of an implied warranty, so the above limitations or exclusions may not apply to you. This Warranty gives you specific legal rights, and you may also have other rights that vary from one jurisdiction to another.

12

Products Covered	Length of coverage
Consumer Products	One (1) year from the date of the products original purchase by the first consumer purchaser of the product.
Consumer Accessories	Ninety (90) days from the date of the accessories original purchase by the first consumer purchaser of the product.
Consumer Products and Accessories that are Repaired or Replaced	The balance of the original warranty or for ninety (90) days from the date returned to the consumer, whichever is longer.

Exclusions

Normal Wear and Tear. Periodic maintenance, repair and replacement of parts due to normal wear and tear are excluded from coverage.

Batteries. Only batteries whose fully charged capacity falls below 80% of their rated capacity and batteries that leak are covered by this Warranty.

Abuse & Misuse. Defects or damage that result from: (a) improper operation, storage, misuse or abuse, accident or neglect, such as physical damage (cracks, scratches, etc.) to the surface of the product resulting from misuse; (b) contact with liquid, water, rain, extreme humidity or heavy perspiration, sand, dirt or the like, extreme heat, or food; (c) use of the Products or Accessories for commercial purposes or subjecting the Product or Accessory to abnormal usage or conditions; or (d) other acts which are not the fault of MOTOROLA or BINATONE, are excluded from coverage.

Use of Non-Motorola branded Products and Accessories. Defects or damage that result from the use of Non-Motorola branded or certified Products or Accessories or other peripheral equipment are excluded from coverage.

Unauthorized Service or Modification. Defects or damages resulting from service, testing, adjustment, installation, maintenance, alteration, or modification in any way by someone other than MOTOROLA, BINATONE or its authorized service centers, are excluded from coverage.

Altered Products. Products or Accessories with (a) serial numbers or date tags that have been removed, altered or obliterated; (b) broken seals or that show evidence of tampering; (c) mismatched board serial numbers; or (d) nonconforming or non-Motorola branded housings, or parts, are excluded

13

from coverage.

Communication Services. Defects, damages, or the failure of Products or Accessories due to any communication service or signal you may subscribe to or use with the Products or Accessories is excluded from coverage.

How to Obtain Warranty Service or Other Information?

To obtain service or information, please call:

UK 0845 218 0890
ROI 08187 62092

You will receive instructions on how to ship the Products or Accessories at your expense and risk, to a BINATONE Authorized Repair Center. To obtain service, you must include: (a) the Product or Accessory; (b) the original proof of purchase (receipt) which includes the date, place and seller of the Product; (c) if a warranty card was included in your box, a completed warranty card showing the serial number of the Product; (d) a written description of the problem; and, most importantly; (e) your address and telephone number. These terms and conditions constitute the complete warranty agreement between you and BINATONE regarding the Products or Accessories purchased by you, and supersede any prior agreement or representations, including representations made in any literature publications or promotional materials issued by BINATONE or representations made by any agent employee or staff of BINATONE, that may have been made in connection with the said purchase.

Technical Specifications

Frequency range	2.40 to 2.48 GHz
Electrical power	Parent and Baby units: Input : 100-240VAC, 50/60Hz (UK/EU plug); Output : 5VDC, 600 mA (Supplier: 5ESP, Model: 5E-AD050060-B/5E-AD050060-E; Supplier: GPE, Model: GPE003W-050060-2/ GPE003W-050060-3) Parent unit: 2.4V 600mAh Ni-MH rechargeable battery pack (Supplier: BYD, Model: H-AAA600BX2-CT; Supplier: GPI, Models: GPRHC063N118; GPRHC063N120 Supplier: SANIK, Model: AAA600)

14

BINATONE TELECOM PLC
1 Apsley Way London NW2 7HF, United Kingdom.
Tel: +44(0) 20 8955 2700 Fax: +44(0) 20 8344 8877
e-mail: binatoneuk@binatoneinternational.com



EC Declaration of Conformity

We the manufacturer / Importer : Binatone Telecom Plc
1 Apsley Way London
NW2 7HF, United Kingdom.

Declare under our sole responsibility that the following product

Type of equipment: Digital Audio Baby Monitor
Model Name: MBP9
Country of Origin: China
Brand: Motorola

complies with the essential protection requirements of R&TTE Directive 1999/5/EC on the approximation of the laws of the Member States relating to **Radio Spectrum Matters**, the Council Directive 2004/108/EC on the approximation of the laws of the Member States relating to **electromagnetic compatibility (EMC)** and the European Community Directive 2006/95/EC relating to **Electrical Safety**.
Assessment of compliance of the product with the requirements relating to the essential requirements according to Article 3 R&TTE was based on Annex III of the Directive 1999/5/EC and the following standard:

Radio Spectrum: EN300328 V1.7.1 (2006-10)
EMC: EN301489-17 V2.1.1 (2009-05)
EN301489-1 V1.8.1 (2008-04)
Electrical Safety: EN60950-1:2006+A11:2009+A1:2010

The product is labelled with the European Approval Marking CE as show. Any Unauthorized modification of the product voids this Declaration.

Manufacturer / Importer
(Signature of authorized person)

Signature: (Paul Tsui/ Product Operation
Director)

London, 5 Jan 12



Place & Date :



Manufactured, distributed or sold by Binatone Electronics International LTD., official licensee for this product. MOTOROLA and the Stylized M Logo are trademarks or registered trademarks of Motorola Trademark Holdings, LLC. and are used under license. All other trademarks are the property of their respective owners.
© 2014 Motorola Mobility LLC. All rights reserved.



Printed in China
Version 6.0