

# New Hallingford - 3 Drawer Bedside

Assembly Instructions - Please keep for future reference

274/4917

266/7379

266/4509

258/7693

266/2910

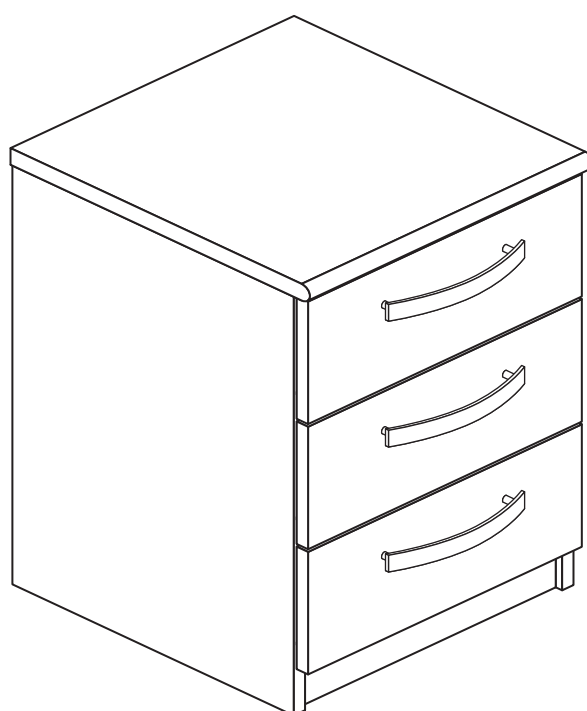

## Dimensions

Width - 37.5cm

Depth - 40cm

Height - 58cm



**MADE IN  
BRITAIN**

**Important** - Please read these instructions fully before starting assembly

If you need help or have damaged or missing parts, call the **Customer Helpline: 0870 112 1928** or email: [Help@ClickSpares.co.uk](mailto:Help@ClickSpares.co.uk) (quoting your original order number)



# Safety and Care Advice

**Important - Please read these instructions fully before starting assembly**

- **Warning:** This unit weighs approximately 14kgs. Please lift with care.

- Check you have all the components and tools listed on pages 2 and 3.

- Remove all fittings from the plastic bags and separate them into their groups.

- Keep children and animals away from the work area, small parts could choke if swallowed.

- Parts of the assembly will be easier with 2 people.

- Make sure you have enough space to layout the parts before starting.

- Do not stand or put weight on the product, this could cause damage.

- Assemble the item as close to its final position (in the same room) as possible.

- Assemble on a soft level surface to avoid damaging the unit or your floor (use opened out unit carton).



- We do not recommend the use of power drill/drivers **for inserting screws**, as this could damage the unit. Only use hand screwdrivers.

- **Safety note:** If there is any chance of this unit being pulled over by children etc. it is recommended that the unit is secured to a wall using suitable fixings (not supplied).

- Dispose of all packaging carefully and responsibly.

## Care and maintenance

- Only clean using a damp cloth and mild detergent, do not use bleach or abrasive cleaners.

- From time to time check that there are no loose screws on this unit.

- This product should not be discarded with household waste. Take to your local authority waste disposal centre.

**Note:** If required the next page can be cut out and used as reference throughout the assembly. Keep this page with these instructions for future reference.

# Components - Panels

If you have damaged or missing components, call the **Customer Helpline: 0870 112 1928** or email: **Help@ClickSpares.co.uk** (quoting your original order number and the reference numbers below)

Please check you have all the panels listed below

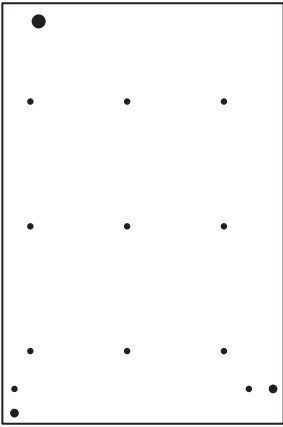

**1** Left Side (D2307A)  
(556 x 372mm)

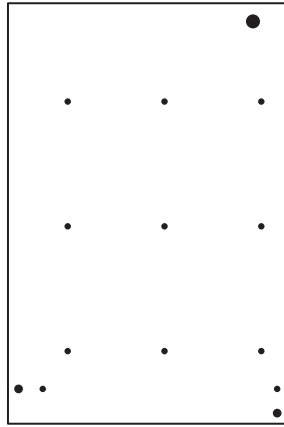

**2** Right Side (D2308A)  
(556 x 372mm)

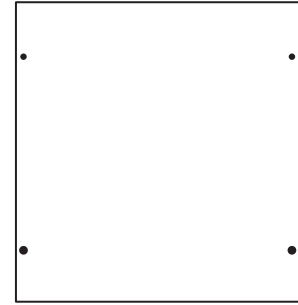

**3** Top (D2306A)  
(375 x 396mm)

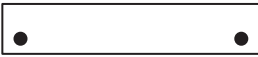

**4** Rail (D2310A)  
(340 x 66mm) x 2

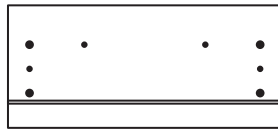

**5** Drawer Front (D2309A)  
(362 x 162mm) x 3

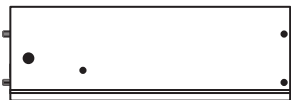

**6** Left Drawer Side (W370-124LH)  
(370 x 124mm) x 3

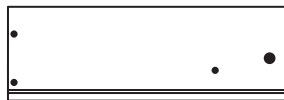

**7** Right Drawer Side (W370-124RH)  
(370 x 124mm) x 3

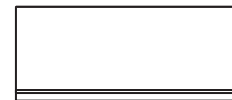

**8** Drawer Back (W291-124)  
(291 x 124mm) x 3

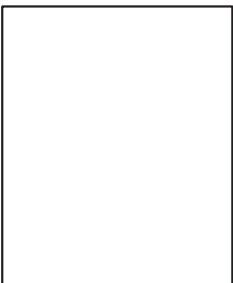

**9** Drawer Base (T304-367)  
(304 x 367mm) x 3



**10** Back (X535-366)  
(535 x 366mm)











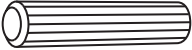
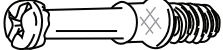

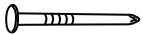

# Components - Fittings

If you have damaged or missing components, call the **Customer Helpline: 0870 112 1928** or **email: Help@ClickSpares.co.uk** (quoting your original order number and the reference numbers below)

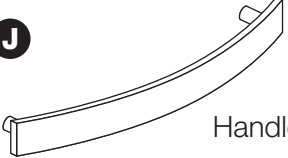
Please check you have all the fittings listed below

**Note:** The quantities below are the correct amount to complete the assembly. In some cases more fittings may be supplied than are required.

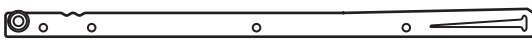
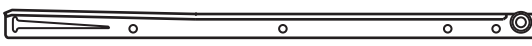
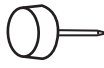
<p><b>A</b> </p> <p>Wooden dowel (F22) x 6</p>	<p><b>B</b> </p> <p>Metal dowel (F901) x 12</p>	<p><b>C</b> </p> <p>Small locking nut (F3) x 6</p>
<p><b>D</b> </p> <p>Large locking nut (F900) x 6</p>	<p><b>E</b> </p> <p>Knock-in Peg (F171GY) x 12</p>	<p><b>F</b> </p> <p>Nail (F51) x 12</p>
<p><b>G</b> </p> <p>19mm Screw (F461) x 6</p>	<p><b>H</b> </p> <p>13mm Screw (F52) x 18</p>	<p><b>I</b> </p> <p>13mm Screw (F63) x 18</p>
<p><b>J</b> </p> <p>Handle (F278) x 3</p>	<p><b>K a</b>  L Runner (F159) x 3            ← 350mm long →</p> <p><b>K b</b>  R Runner (F160) x 3</p>	
<p><b>L</b> </p> <p>Wedgifix (F639) x 6</p>	<p><b>K c</b>  L Runner (F161) x 3</p> <p><b>K d</b>  R Runner (F162) x 3</p>	
<p><b>M</b> </p> <p>Plastic Nail (F91) x 4</p>		

## Tools required



Rule



Cross-head screwdriver



Scissors



Hammer



Eye protection (when using a hammer or drill)



Electric drill (do not use for fitting screws)

**Ruler** - Use this ruler to help correctly identify the screws

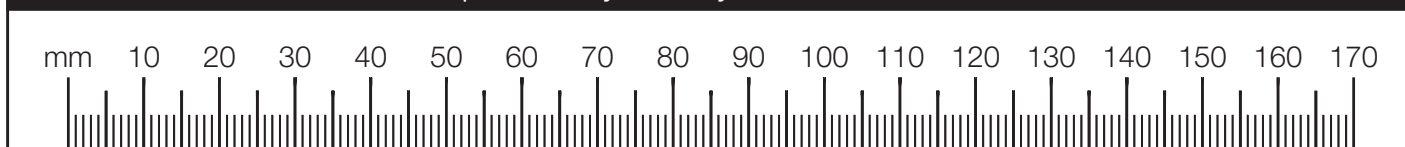



# Assembly Instructions

If you have damaged or missing components, call the Customer Helpline: 0870 112 1928 or email: [Help@ClickSpares.co.uk](mailto:Help@ClickSpares.co.uk) (quoting your original order number and the reference numbers below)

## Step 1

### Prepare the 3 drawer fronts

Screw 2 metal dowels **B** into the holes shown on the back of each drawer front **5**.

**Note:** Tighten metal dowels up fully against the panels.

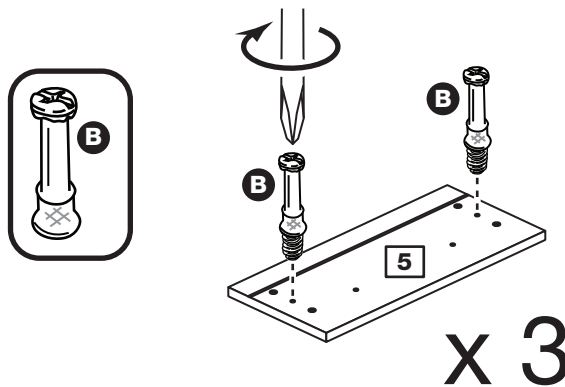

## Step 2

### Prepare the drawer sides

Insert a small locking nut **C** into the hole shown on the left drawer side **6** and right drawer side **7**.

**Note:** Arrow on locking nut **must** point towards hole in edge of panel.

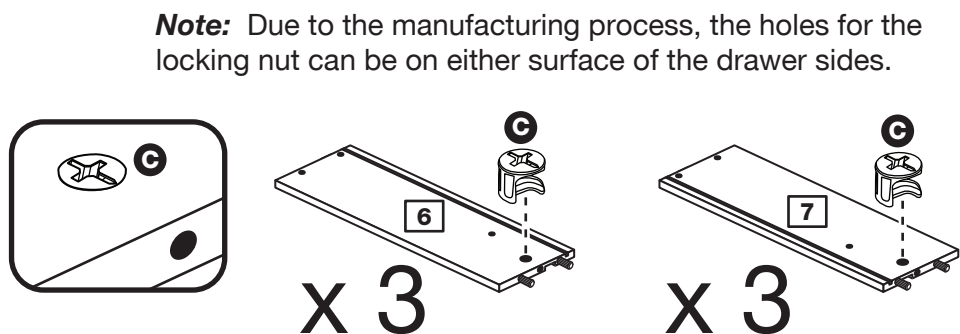

## Step 3

### Attach the drawer sides to the drawer front

Push the left drawer side **6** and right drawer side **7** onto the back of the drawer front **5**.

Turn the small locking nuts **C** on the left drawer side **6** and right drawer side **7**.

**Note:** Turn the locking nuts **C** clockwise to secure panels - more than 1/2 a turn.

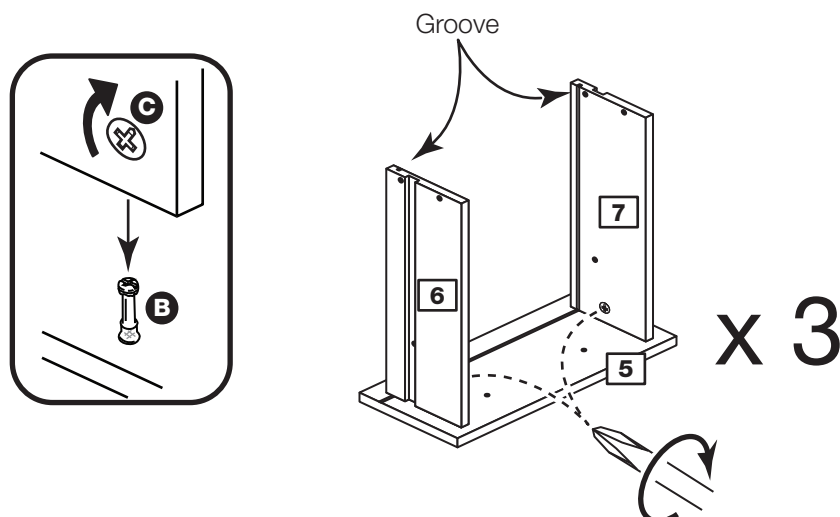

# Assembly Instructions

## Step 4

### Fit the drawer base

Slide the drawer base **9** down the grooves in the drawer sides **6** and **7** and down into the groove in the drawer front **5**.

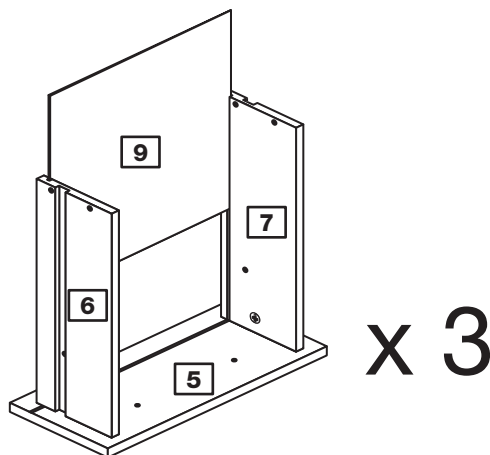

## Step 5

### Fit the drawer back

Fit the drawer back **8** between the drawer sides **6** and **7**.

Make sure that the drawer base **9** fits into the groove in the drawer back **8**.

Hold the drawer back **8** in position and tap the knock-in pegs **E** through the holes in the drawer sides **6** and **7**.

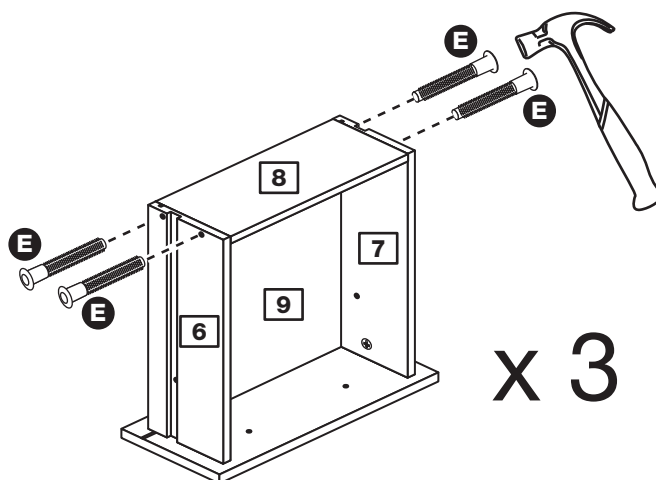

## Step 6

### Attach the handle

Attach a handle **J** to each drawer front **5** using 2 screws **G**.

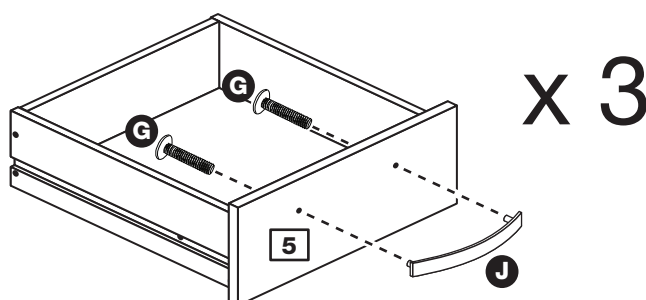

## Step 7

### Fit the wedgifixes

Turn the drawer assemblies over and slide 2 wedgifixes **L** into the front and back grooves, as shown, and tighten up the screws.

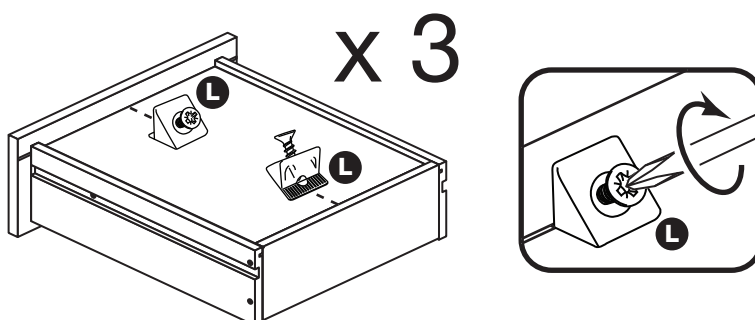

# Assembly Instructions

## Step 8

### Fit runners to the drawers

Turn the 3 drawer assemblies over.

Fit runner **Kd**, marked with 'R', to the bottom edge of the right drawer side **7**, as shown, making sure that it is pushed up against the back of the drawer front **5**.

Use a bradawl to mark the fixing positions, then secure with 2 screws **I**.

Fit runner **Kc**, marked 'L', to the bottom edge of the left drawer side **6** using the same method.

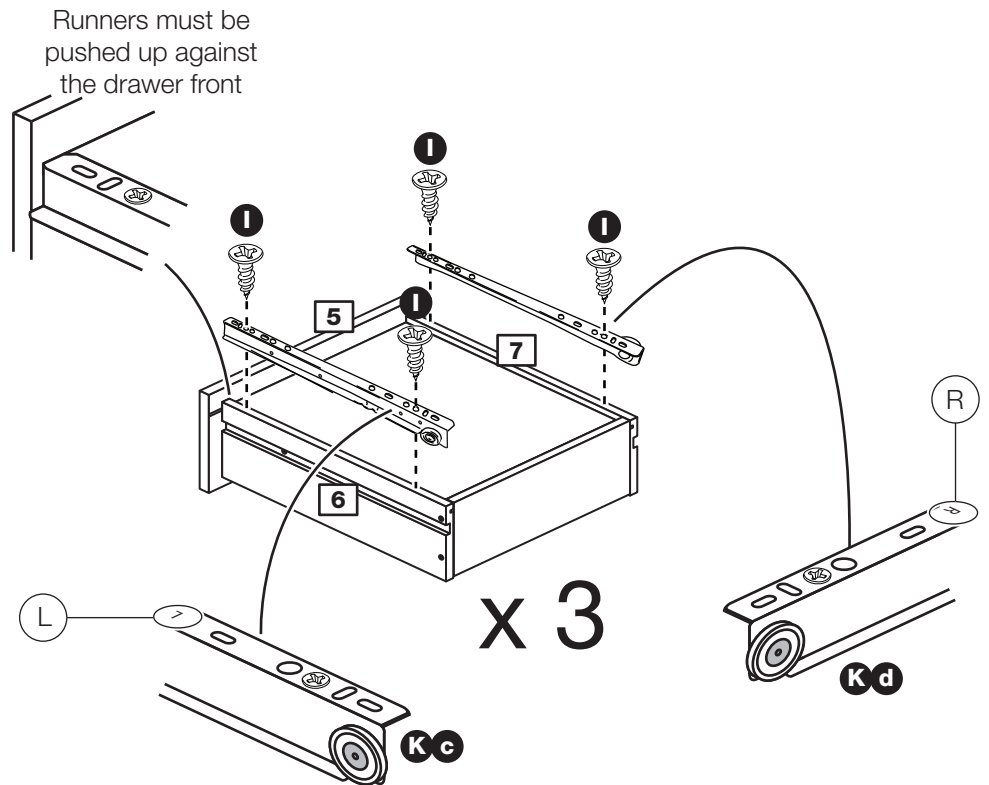

## Step 9

### Prepare the 2 rails

Tap 2 wooden dowels **A** into each rail **4**.

**Note:** Wooden dowels **must not** stick out from the edge by more than 10mm or they may damage other panels.

Insert 2 large locking nuts **D** into each rail **4**.

**Note:** The arrow on the locking nut **must** point towards the hole in the edge of the panel.

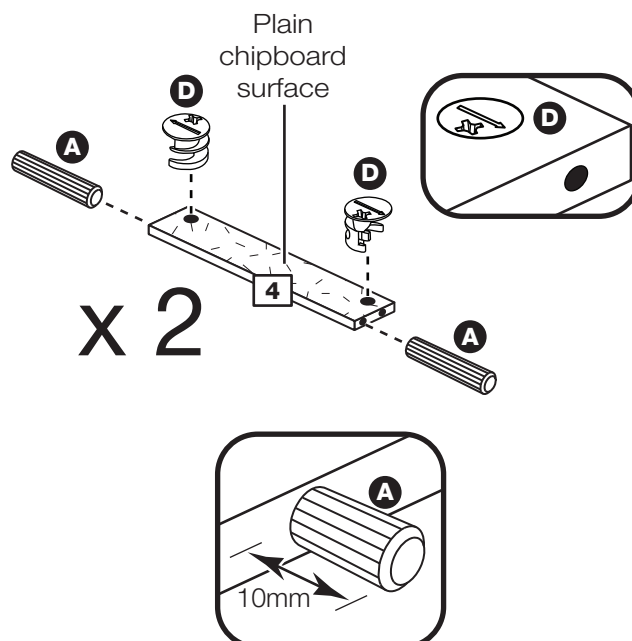

# Assembly Instructions

## Step 10

### Prepare the left side

**a:** Fit 3 runners **K a** to the left side **1**.

The 1st screw **H** uses the 2nd hole in from the front of the runner.

The 2nd and 3rd screws **H** use the holes that line up with the other panel holes.

**b:** Fit a screw **I** into the 2nd hole in at the top of the runners **K a**.

Screw 2 metal dowels **B** into the left side **1**.

Insert a large locking nut **D** into the left side **1**.

Tap a wooden dowel **A** into the left side **1**.

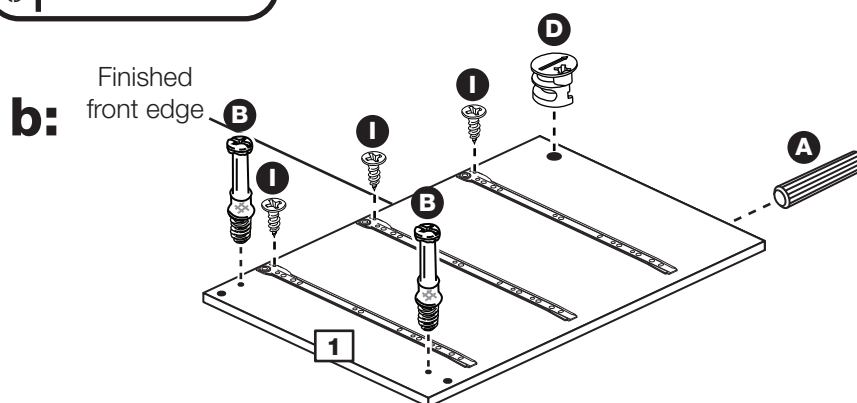
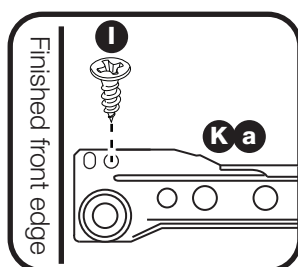
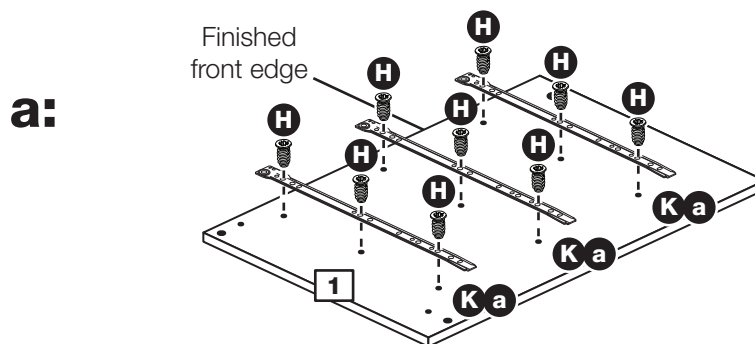
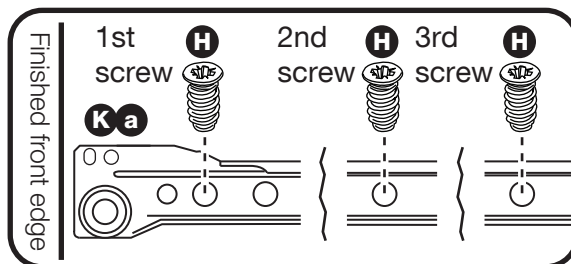

# Assembly Instructions

## Step 11

### Prepare the right side

**a:** Fit 3 runners **K b** to the right side **2**.

The 1st screw **H** uses the 2nd hole in from the front of the runner.

The 2nd and 3rd screws **H** use the holes that line up with the other panel holes.

**b:** Fit a screw **I** into the 2nd hole in at the top of the runner **K b**.

Screw 2 metal dowels **B** into the right side **2**.

Insert a large locking nut **D** into the right side **2**.

Tap a wooden dowel **A** into the right side **2**.

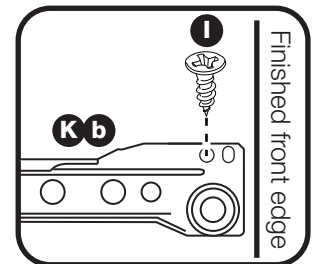
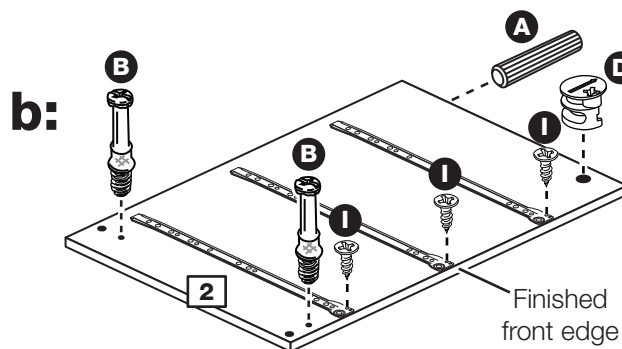
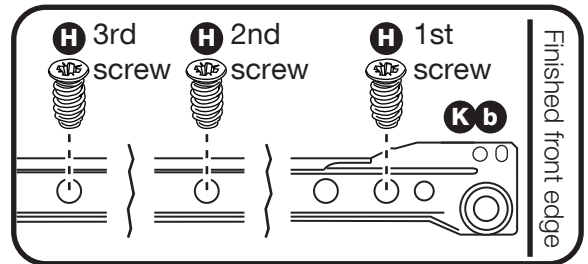
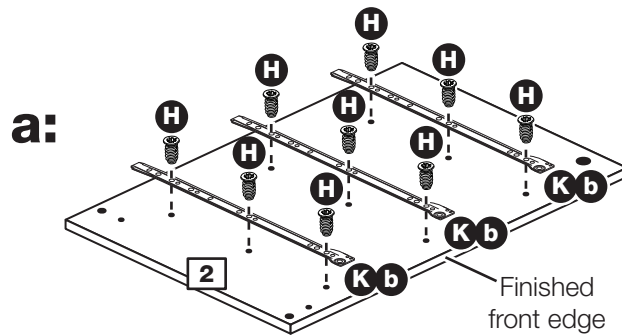

## Step 12

### Join the right side and rails

Push the 2 rails **4** onto the right side **2**.

Use a screwdriver to tighten the 2 large locking nuts **D** fitted to the rails **4**.

**Note:** Turn the large locking nuts **D** as far as they will go - more than 1/2 a turn.

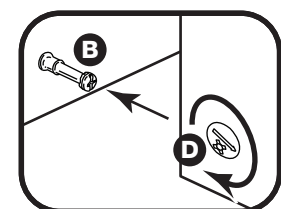
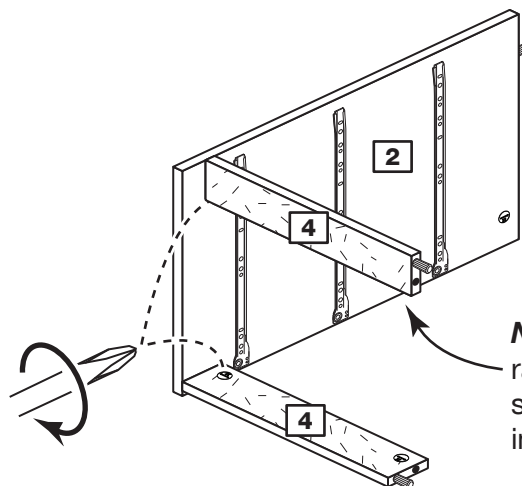

**Note:** Support this rail until the left side has been fitted in the next step.

# Assembly Instructions

## Step 13

### Fit the left side

Push the left side **1** onto the 2 rails **4**.

Use a screwdriver to tighten the 2 large locking nuts **D** fitted to the rails **4**.

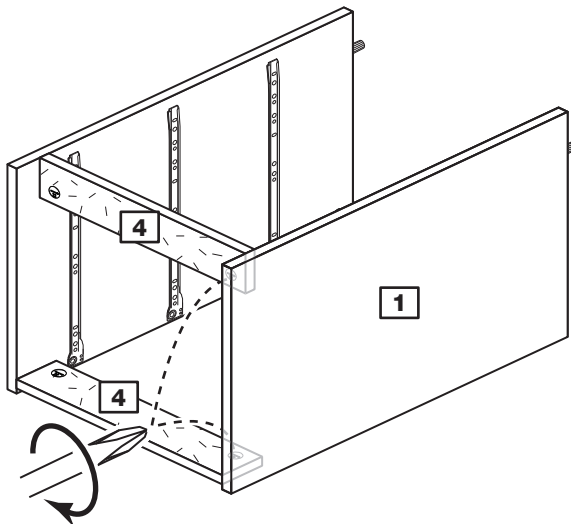

## Step 14

### Prepare the top

Screw 2 metal dowels **B** into the top **3**.

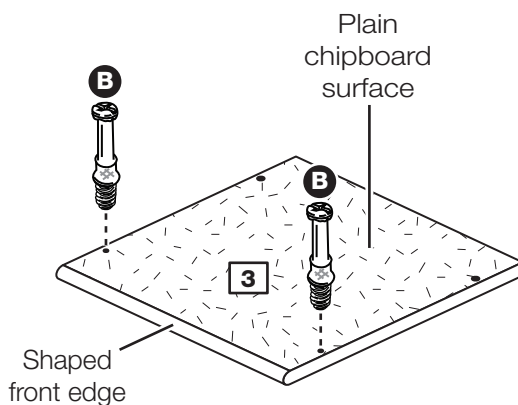

## Step 15

### Fit the top

Push the top **3** onto the 2 sides **1** and **2**.

Use a screwdriver to tighten the 2 large locking nuts **D** fitted to the sides **1** and **2**.

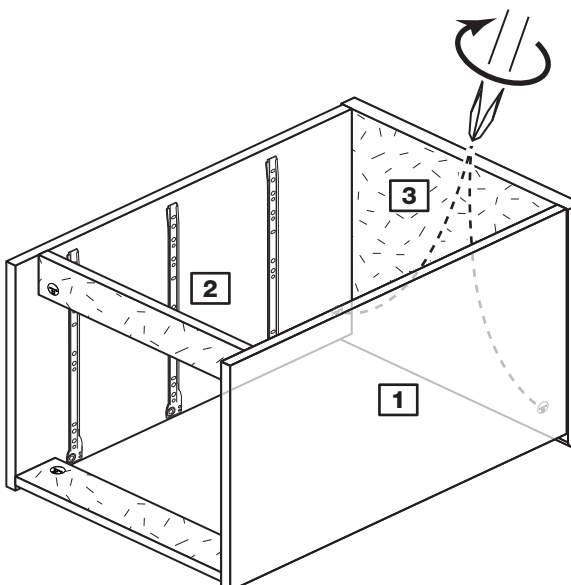

# Assembly Instructions

## Step 16

### Fit the back

**a:** Square up the unit by making sure that measurement **x** to **x** equals **y** to **y**.

**b:** Place the back **10** onto the unit.

Nail **F** around the outside edges of the back **10**.

**Note:** Nails should be spaced about 150mm apart.

**Stand the unit up for the next step.**



**Warning:** The unit is heavy. Lift with care.

**a:** The measurement from top corner X to bottom corner X must be equal to the measurement from top corner Y to bottom corner Y

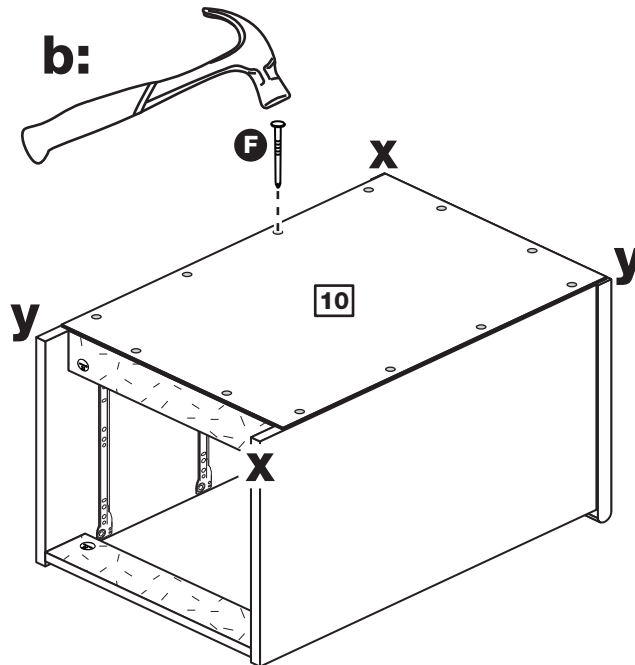

## Step 17

### Fit the 4 plastic nails

Tap 2 plastic nails **M** into the bottom edge of each of the sides **1** and **2**.

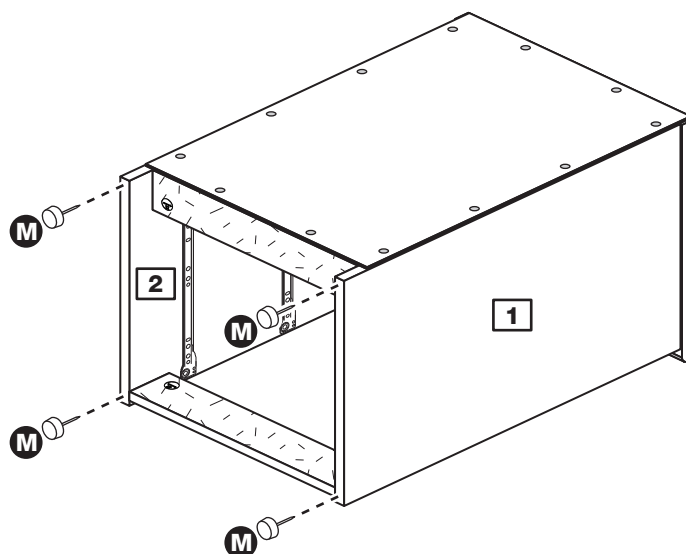

# Assembly Instructions

## Step 18

### Fit the drawers

Slide the wheels of the runners fitted to the drawers, over the wheels of the runners fitted to the side panels and push the drawers into position.

**Assembly is complete**

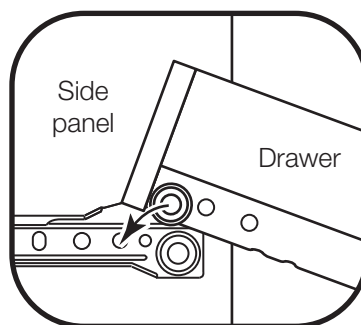
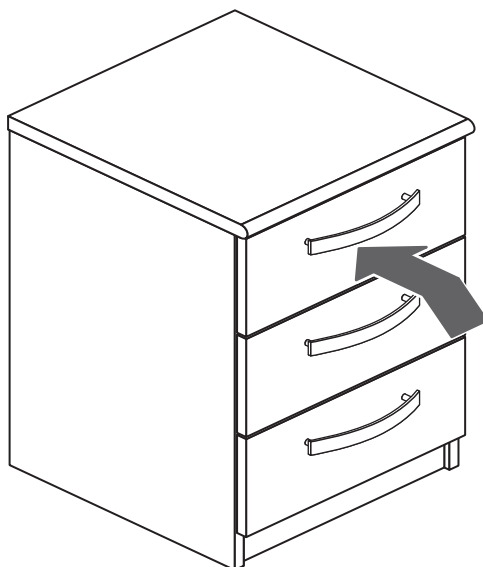

If you need help or have damaged or missing parts, call the **Customer Helpline: 0870 112 1928** or email: **Help@ClickSpares.co.uk** (quoting your original order number and the reference numbers on the component pages)  
Argos Ltd, 489-499 Avebury Boulevard, Central Milton Keynes, MK9 2NW



# New Hallingford - 4+4 Drawer Chest

Assembly Instructions - Please keep for future reference

266/5508

258/6625

268/9577

262/1638

245/7510

272 825

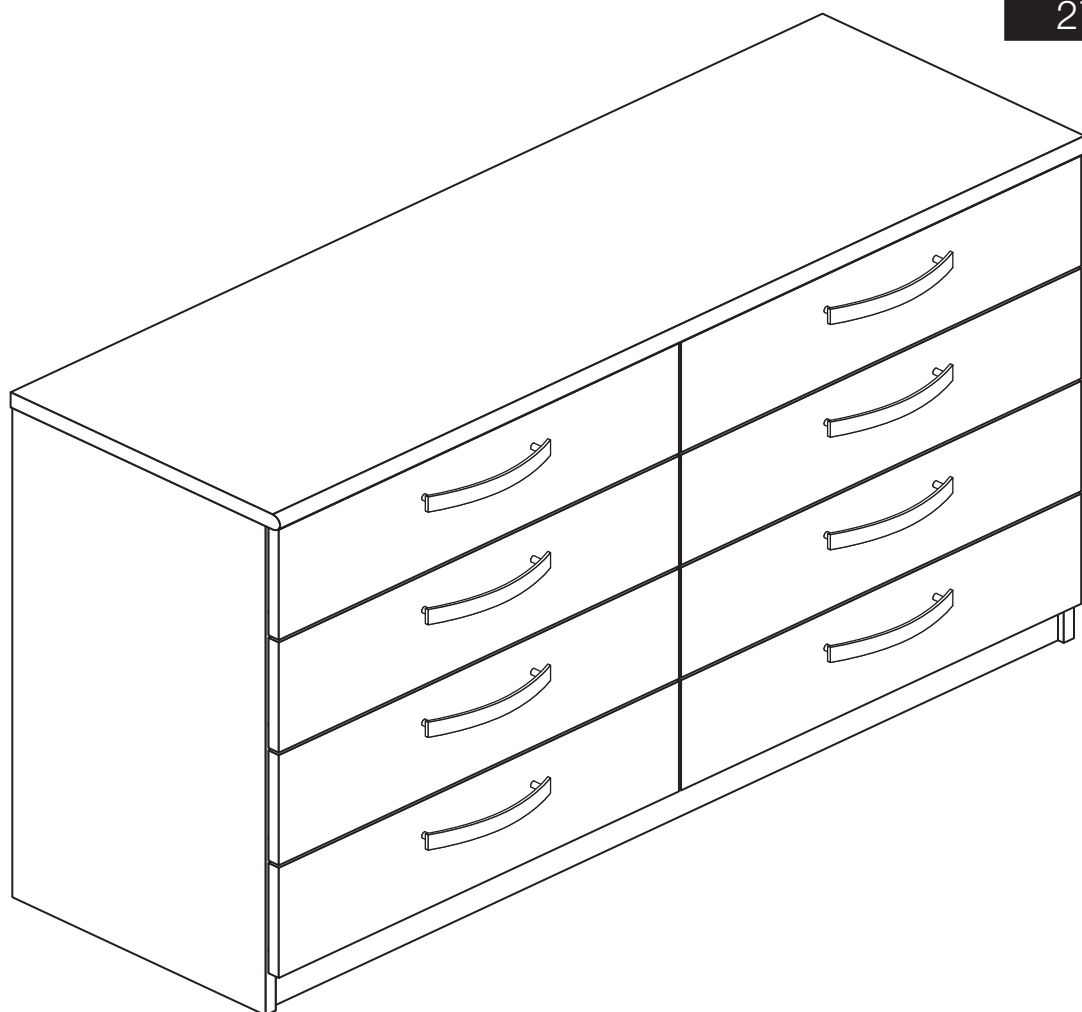

## Dimensions

Width - 119.5cm

Depth - 40cm

Height - 74.5cm



**MADE IN  
BRITAIN**

**Important** - Please read these instructions fully before starting assembly

If you need help or have damaged or missing parts, call the **Customer Helpline: 0870 112 1928** or email: [Help@ClickSpares.co.uk](mailto:Help@ClickSpares.co.uk) (quoting your original order number)



# Safety and Care Advice

**Important - Please read these instructions fully before starting assembly**

- **Warning:** This unit weighs approximately 41.5kgs. Please lift with care.

- Check you have all the components and tools listed on pages 2 and 3.

- Remove all fittings from the plastic bags and separate them into their groups.

- Keep children and animals away from the work area, small parts could choke if swallowed.

- Parts of the assembly will be easier with 2 people.

- Make sure you have enough space to layout the parts before starting.

- Do not stand or put weight on the product, this could cause damage.

- Assemble the item as close to its final position (in the same room) as possible.

- Assemble on a soft level surface to avoid damaging the unit or your floor (use opened out unit carton).



- We do not recommend the use of power drill/drivers **for inserting screws**, as this could damage the unit. Only use hand screwdrivers.

- **Safety note:** If there is any chance of this unit being pulled over by children etc. it is recommended that the unit is secured to a wall using suitable fixings (not supplied).

- Dispose of all packaging carefully and responsibly.

## Care and maintenance

- Only clean using a damp cloth and mild detergent, do not use bleach or abrasive cleaners.

- From time to time check that there are no loose screws on this unit.

- This product should not be discarded with household waste. Take to your local authority waste disposal centre.

**Note:** If required the next page can be cut out and used as reference throughout the assembly. Keep this page with these instructions for future reference.

# Components - Panels

If you have damaged or missing components, call the **Customer Helpline: 0870 112 1928** or email: **Help@ClickSpares.co.uk** (quoting your original order number and the reference numbers below)

Please check you have all the panels listed below

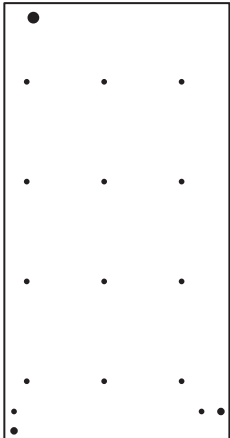

**1** Left Side (D2312A)  
(721 x 372mm)

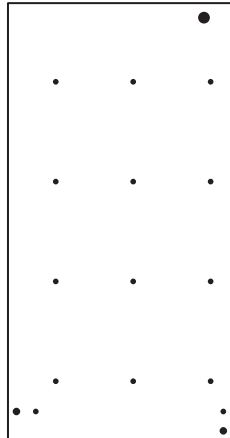

**2** Right Side (D2313A)  
(721 x 372mm)

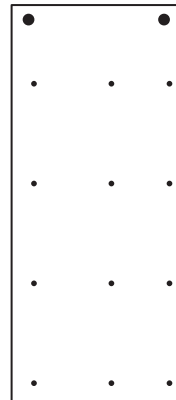

**3** Upright (D2323A)  
(655 x 282mm)

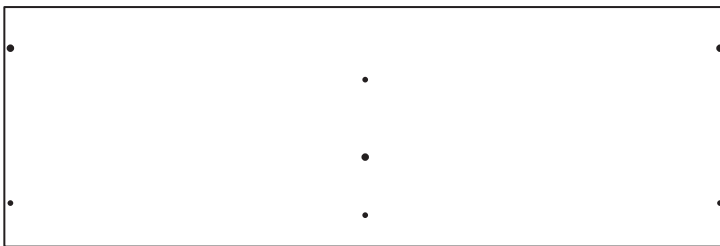

**4** Top (D2322A)  
(1193 x 396mm)

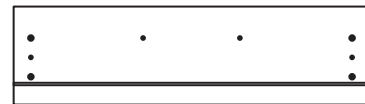

**5** Drawer Front (D2324A)  
(588 x 162mm) x 8



**6** Rail (D2325A)  
(1158 x 66mm) x 2



**7** Drawer Base (T529-367)  
(529 x 367mm) x 8



**8** Left Drawer Side (W370-124LH)  
(370 x 124mm) x 8



**9** Right Drawer Side (W370-124RH)  
(370 x 124mm) x 8



**10** Drawer Back (W518-124)  
(518 x 124mm) x 8

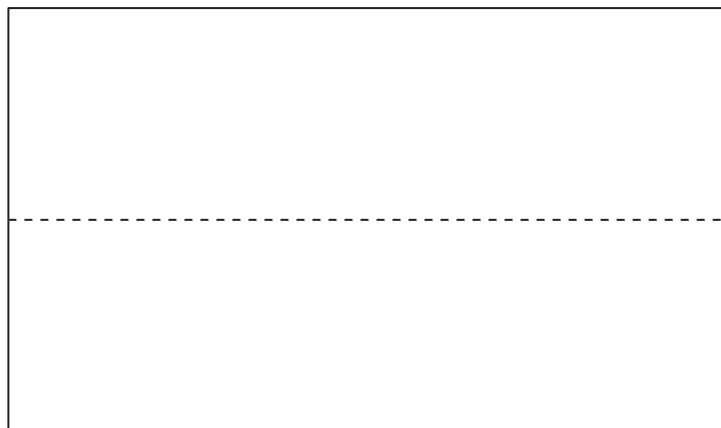

**11** Back (X1184-700)  
(1184 x 700mm)











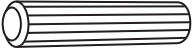
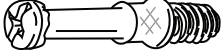

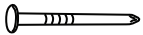

# Components - Fittings

If you have damaged or missing components, call the **Customer Helpline: 0870 112 1928** or **email: Help@ClickSpares.co.uk** (quoting your original order number and the reference numbers below)

Please check you have all the fittings listed below

**Note:** The quantities below are the correct amount to complete the assembly. In some cases more fittings may be supplied than are required.

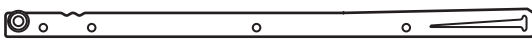
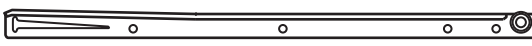
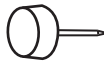
<p><b>A</b> </p> <p>Wooden dowel (F22) x 7</p>	<p><b>B</b> </p> <p>Metal dowel (F901) x 24</p>	<p><b>C</b> </p> <p>Small locking nut (F3) x 16</p>
<p><b>D</b> </p> <p>Large locking nut (F900) x 8</p>	<p><b>E</b> </p> <p>Knock-in Peg (F171GY) x 32</p>	<p><b>F</b> </p> <p>Nail (F51) x 26</p>
<p><b>G</b> </p> <p>19mm Screw (F461) x 16</p>	<p><b>H</b> </p> <p>13mm Screw (F52) x 48</p>	<p><b>I</b> </p> <p>13mm Screw (F63) x 48</p>
<p><b>J</b> </p> <p>Handle (F278) x 8</p>	<p><b>K a</b>  L Runner (F159) x 8            ← 350mm long →</p> <p><b>K b</b>  R Runner (F160) x 8</p>	
<p><b>L</b> </p> <p>Wedgfix (F639) x 32</p>	<p><b>K c</b>  L Runner (F161) x 8</p> <p><b>K d</b>  R Runner (F162) x 8</p>	
<p><b>M</b> </p> <p>Plastic Nail (F91) x 5</p>		

## Tools required



Rule



Cross-head screwdriver



Scissors



Hammer



Eye protection (when using a hammer or drill)



Electric drill (do not use for fitting screws)

**Ruler** - Use this ruler to help correctly identify the screws

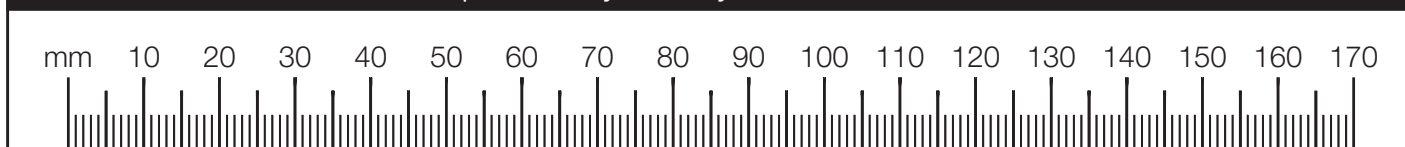

# Assembly Instructions

If you have damaged or missing components, call the Customer Helpline: 0870 112 1928 or email: [Help@ClickSpares.co.uk](mailto:Help@ClickSpares.co.uk) (quoting your original order number and the reference numbers below)

## Step 1

### Prepare the drawer fronts

Screw 2 metal dowels **B** into the holes shown on the back of each drawer front **5**.

**Note:** Tighten the metal dowels up fully against the panels.

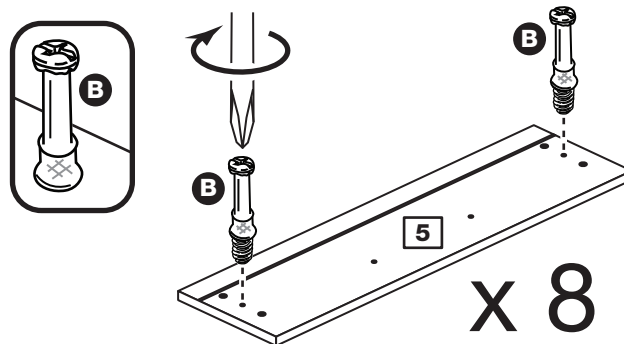

## Step 2

### Prepare the drawer sides

Insert a small locking nut **C** into the hole shown on the left drawer side **8** and right drawer side **9**.

**Note:** The arrow on the locking nut **must** point towards the hole in the edge of the panel.

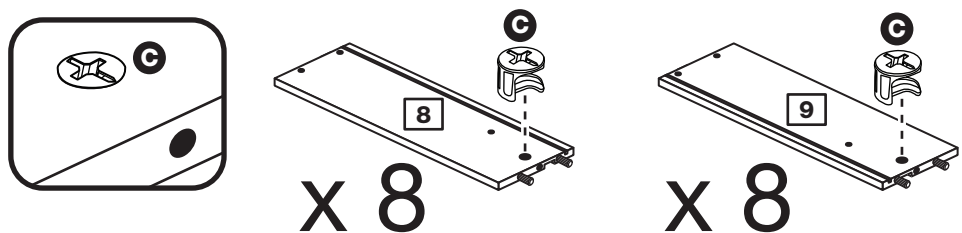

## Step 3

### Attach the drawer sides to the drawer front

Push the left drawer side **8** and right drawer side **9** onto the back of the drawer front **5**.

Turn the small locking nuts **C** on the left drawer side **8** and right drawer side **9**.

**Note:** Turn the locking nuts **C** clockwise to secure panels - more than 1/2 a turn.

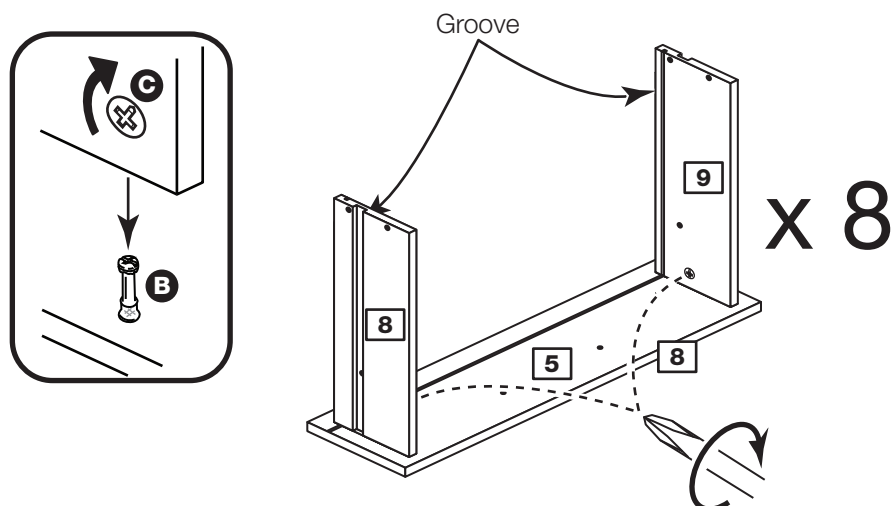

**Note:** The locking nuts can be on either surface of the drawer sides. Make sure that the groove is on the inside, as shown.

# Assembly Instructions

## Step 4

### Fit the drawer base

Slide the drawer base **7** down the grooves in the drawer sides **8** and **9** and down into the groove in the drawer front **5**.

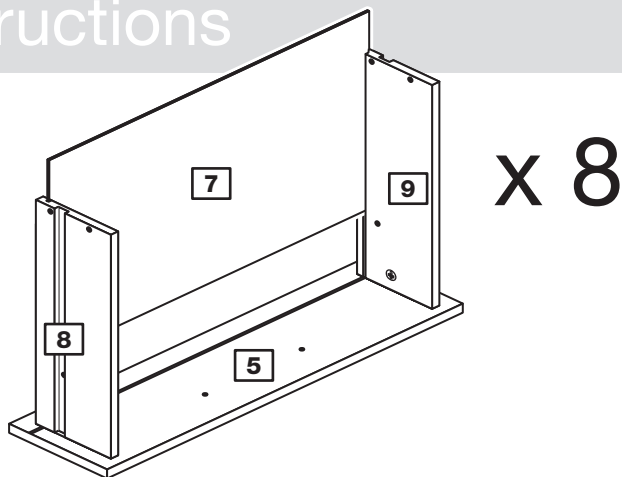

## Step 5

### Fit the drawer back

Fit the drawer back **10** between the drawer sides **8** and **9**.

Make sure that the drawer base **7** fits into the groove in the drawer back **10**.

Hold the drawer back **10** in position and tap the knock-in pegs **E** through the holes in the drawer sides **8** and **9**.

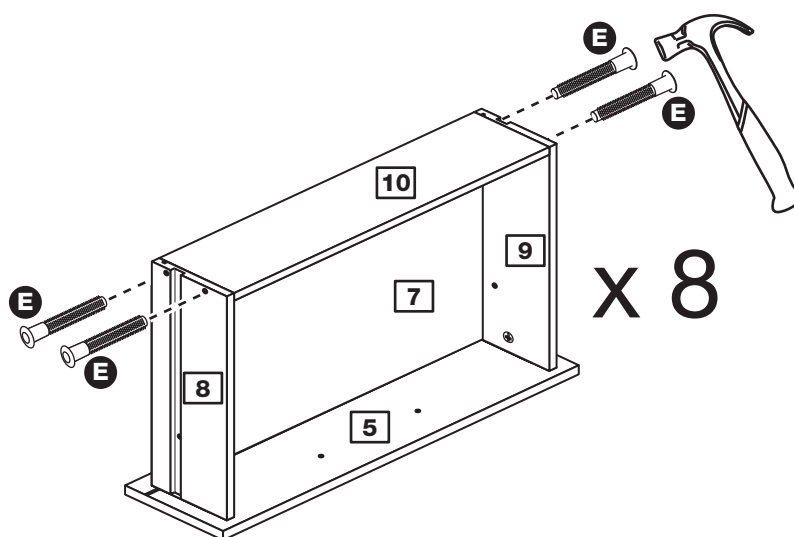

## Step 6

### Attach the handles

Attach a handle **J** to each drawer front **5** using 2 screws **G**.

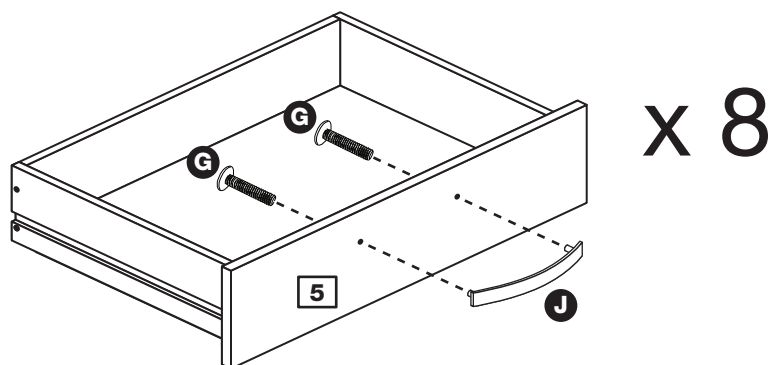

## Step 7

### Fit the wedgexes

Turn the drawer assemblies over and slide 4 wedgexes **L** into the front and back grooves, as shown, and tighten up the screws.

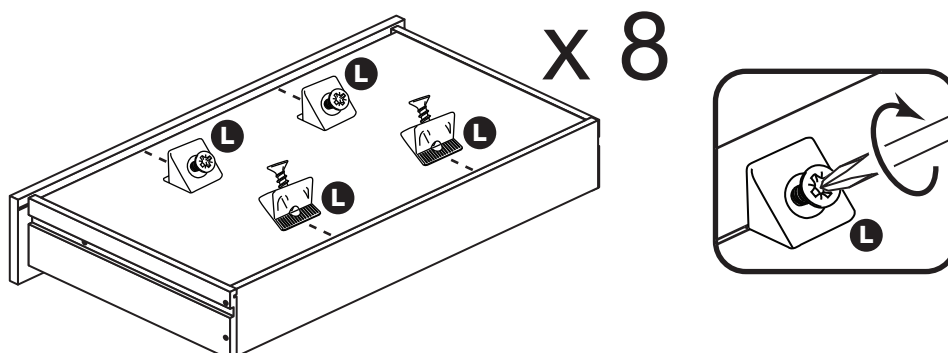

# Assembly Instructions

## Step 8

### Fit runners to the drawers

Fit runner **Kd**, marked with 'R', to the bottom edge of the right drawer side **9**, as shown, making sure that it is pushed up against the back of the drawer front **5**.

Use a bradawl to mark the fixing positions, then secure with 2 screws **I**.

Fit runner **Kc**, marked 'L', to the bottom edge of the left drawer side **8** using the same method.

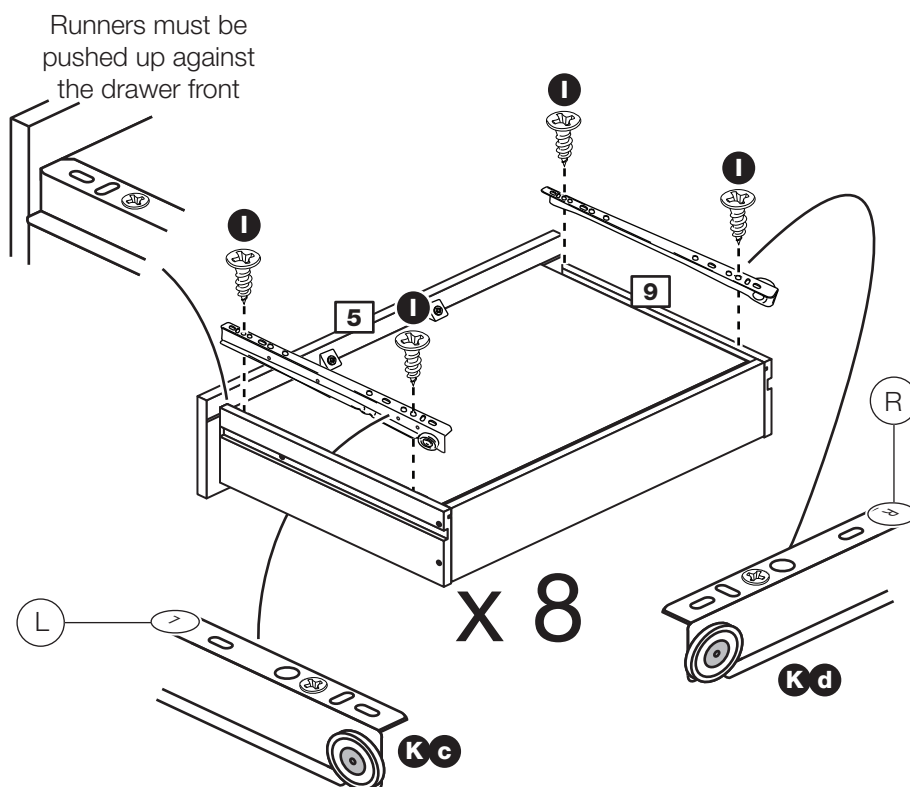

## Step 9

### Prepare the 2 rails

Tap 2 wooden dowels **A** into each rail **6**.

**Note:** Wooden dowels **must not** stick out from the edge by more than 10mm or they may damage other panels.

Insert 2 large locking nuts **D** into each rail **6**.

**Note:** The arrow on the locking nut **must** point towards the hole in the edge of the panel.

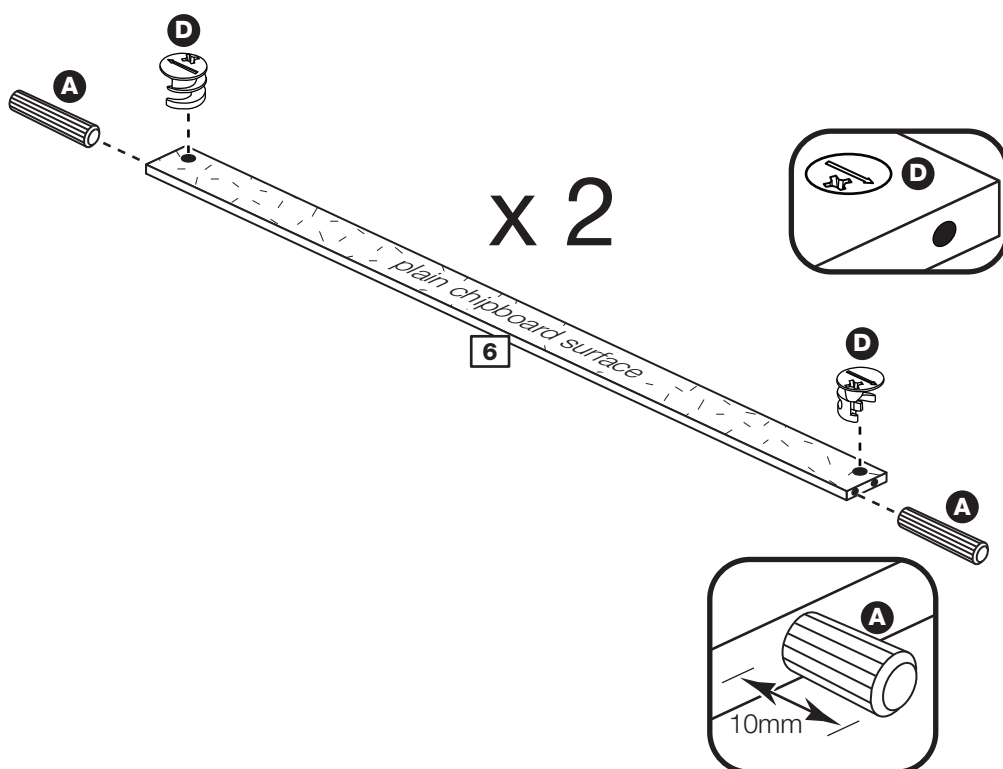

# Assembly Instructions

## Step 10

### Prepare the left side

**a:** Fit 4 runners **K a** to the left side **1**.

The 1st screw **H** uses the 2nd hole in from the front of the runner.

The 2nd and 3rd screws **H** use the holes that line up with the other panel holes.

**b:** Fit a screw **I** into the 2nd hole in at the top of the runners **K a**.

Screw 2 metal dowels **B** into the left side **1**.

Insert a large locking nut **D** into the left side **1**.

**Note:** The arrow on the locking nut **must** point towards the hole in the edge of the panel.

Tap a wooden dowel **A** into the left side **1**.

**Note:** Wooden dowels **must not** stick out from the edge by more than 10mm or they may damage other panels.

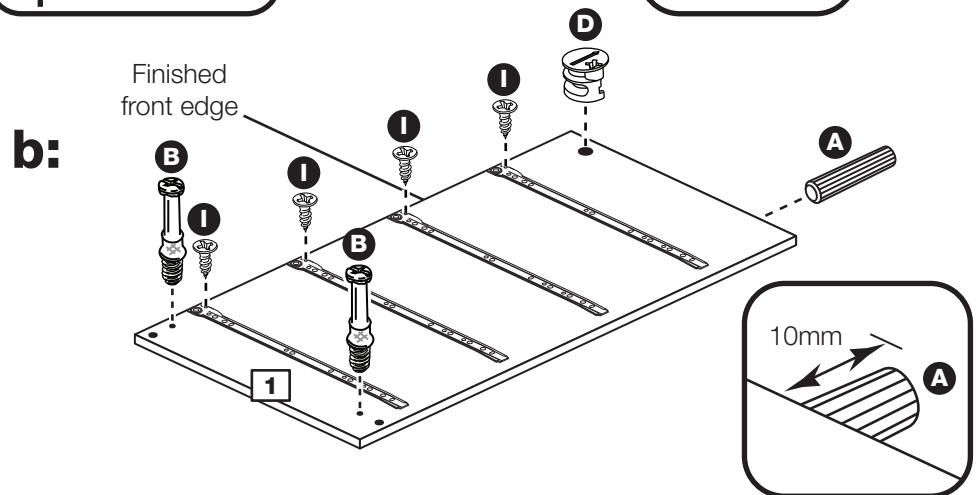
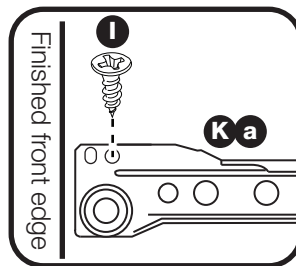
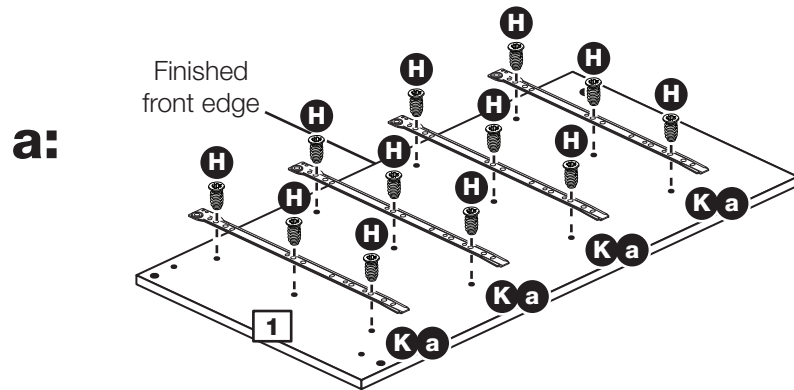
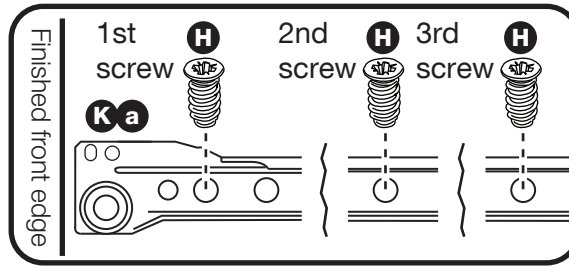



# Assembly Instructions

## Step 11

### Prepare the right side

**a:** Fit 4 runners **K b** to the right side **2**.

The 1st screw **H** uses the 2nd hole in from the front of the runner.

The 2nd and 3rd screws **H** use the holes that line up with the other panel holes.

**b:** Fit a screw **I** into the 2nd hole in at the top of the runner **K b**.

Screw 2 metal dowels **B** into the right side **2**.

Insert a large locking nut **D** into the right side **2**.

Tap a wooden dowel **A** into the right side **2**.

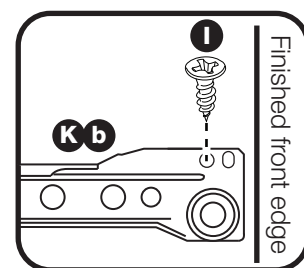
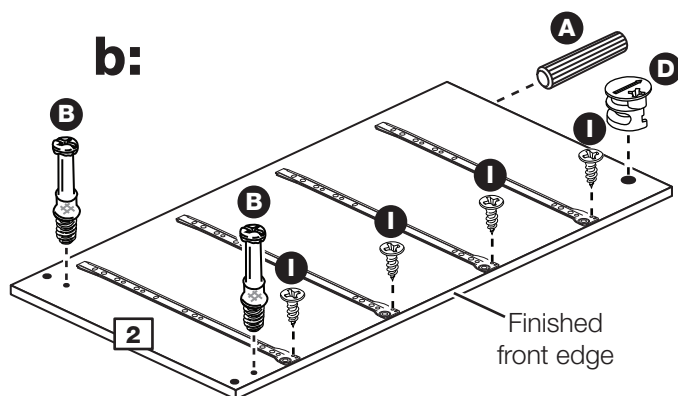
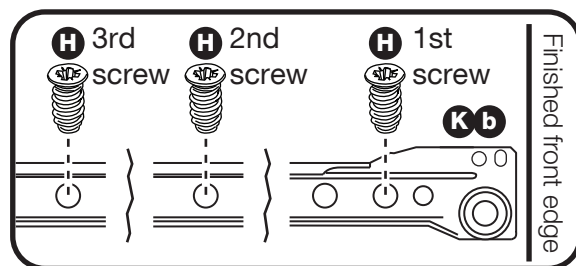
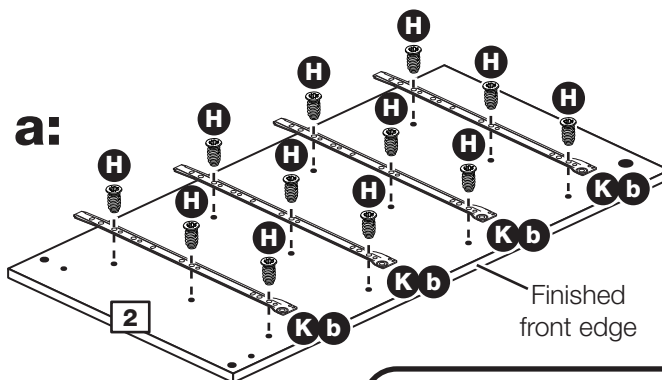

# Assembly Instructions

## Step 12

### Join the right side and rails

**2 people are needed here**

Push the 2 rails **6** onto the right side **2**.

Use a screwdriver to tighten the 2 large locking nuts **D** fitted to the rails **6**.

**Note:** Turn the large locking nuts **D** as far as they will go - more than 1/2 a turn.

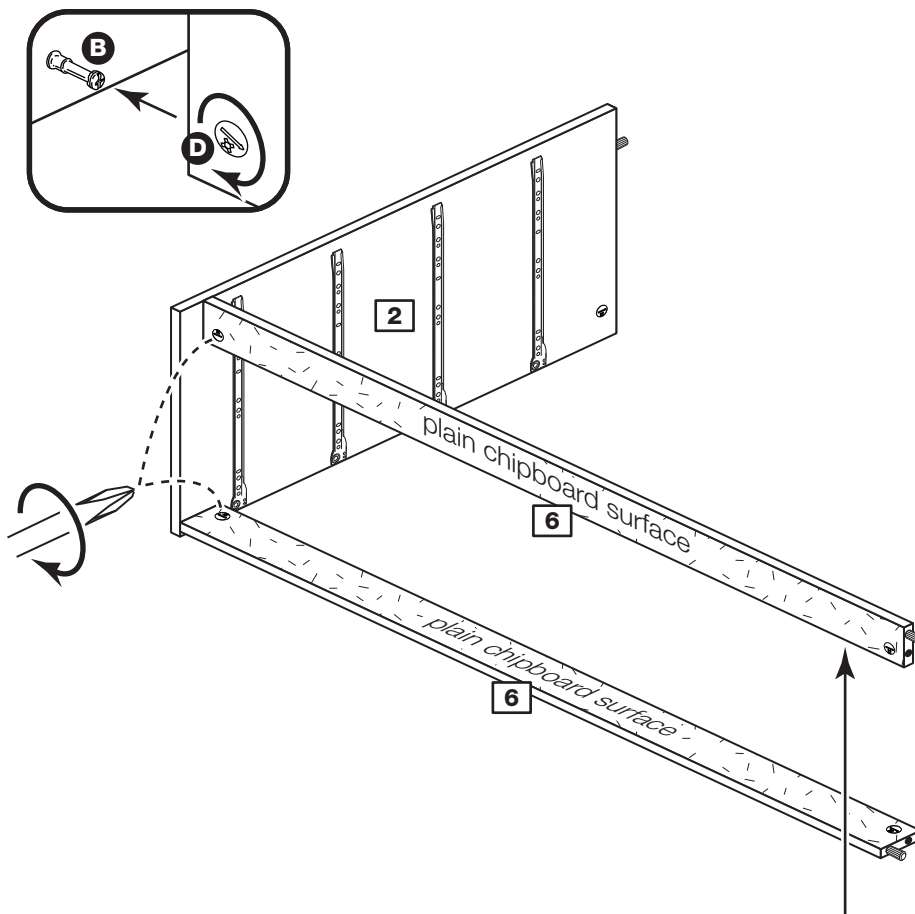

**Note:** Support this rail until the left side has been fitted in the next step.

## Step 13

### Fit the left side

Push the left side **1** onto the 2 rails **6**.

Use a screwdriver to tighten the 2 large locking nuts **D** fitted to the rails **6**.

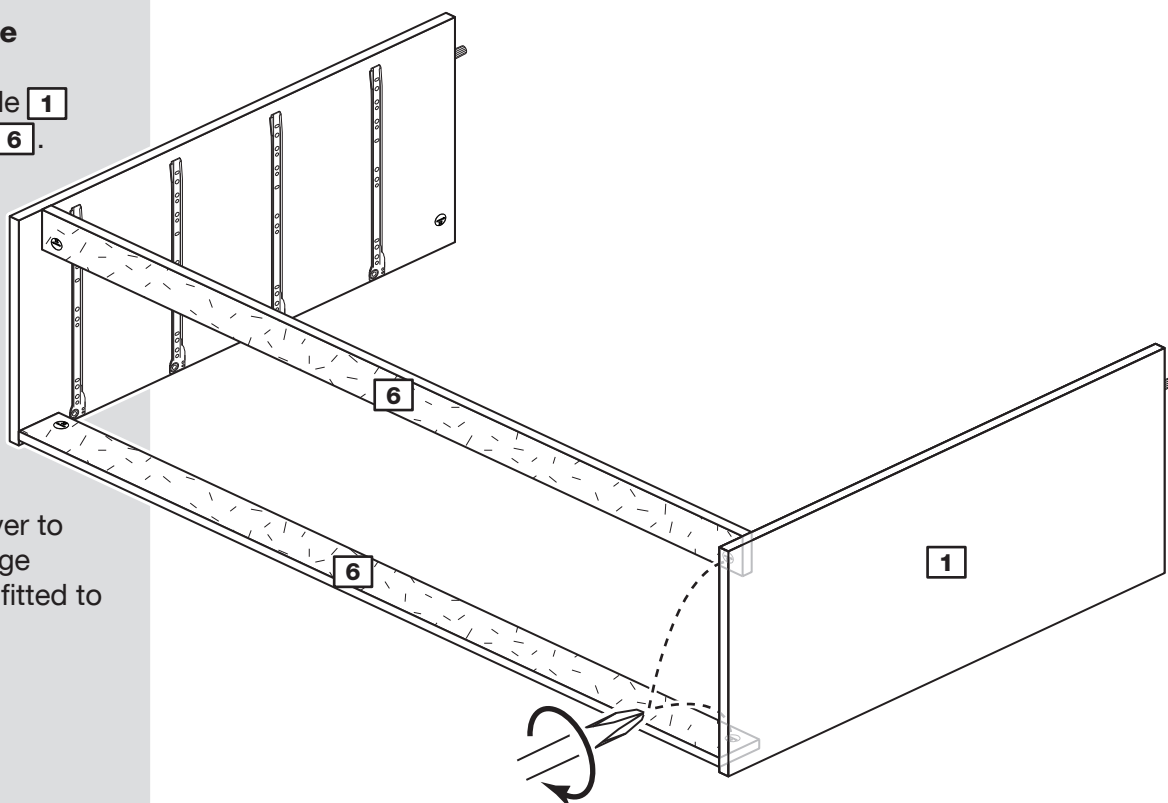

# Assembly Instructions

## Step 14

### Prepare the first surface of the upright

**Note:** The colour of the upright may differ from the main unit colour.

**a:** Fit 4 runners **K b** to the upright **3**.

The 1st screw **H** uses the 2nd hole in from the front of the runner.

The 2nd and 3rd screws **H** use the holes that line up with the other panel holes.

**b:** Fit a screw **I** into the 2nd hole in at the top of the runner **K b**.

Tap a wooden dowel **A** into the upright **3**.

**Turn the upright over for the next step**

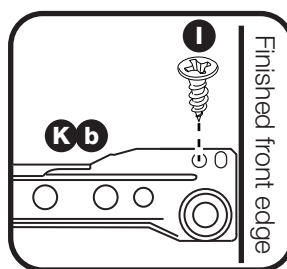
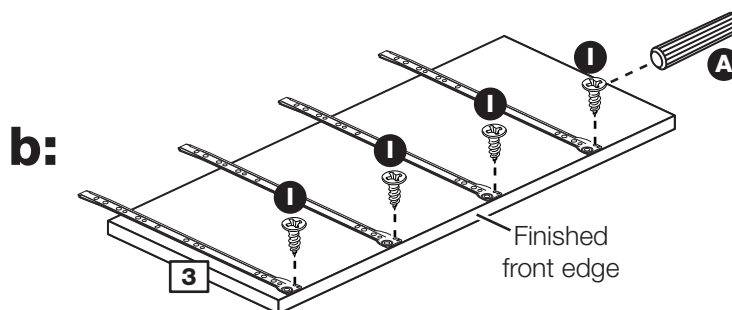
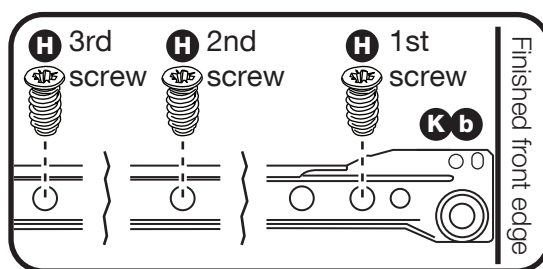
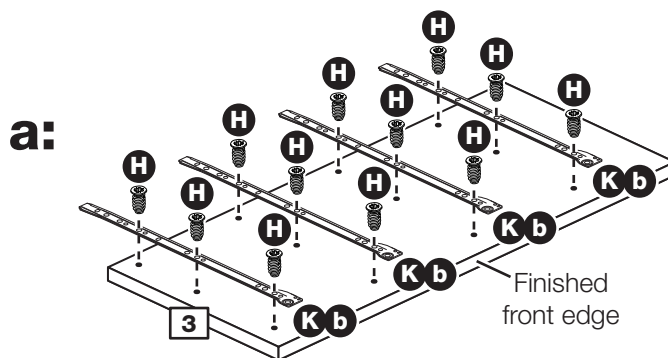

**Turn the divider over**

# Assembly Instructions

## Step 15

### Prepare the other surface of the upright

**a:** Fit 4 runners **K a** to the upright **3**.

The 1st screw **H** uses the 2nd hole from the front of the runner.

The 2nd and 3rd screws **H** use the holes that line up with the other panel holes.

**b:** Fit a screw **I** into the 2nd hole in at the top of the runner **K a**.

Insert 2 large locking nuts **D** into the upright **3**.

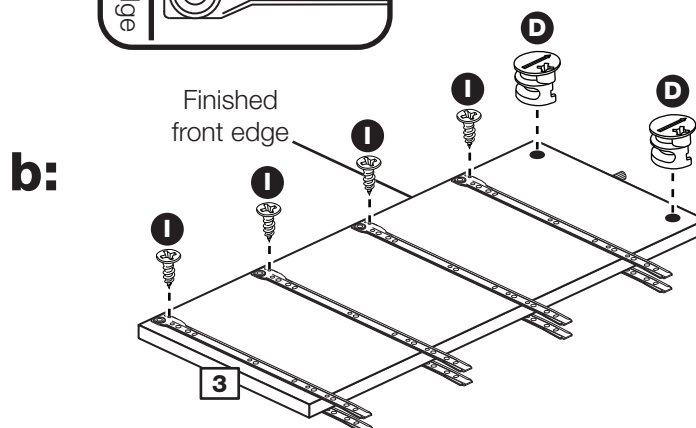
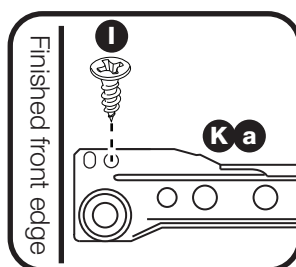
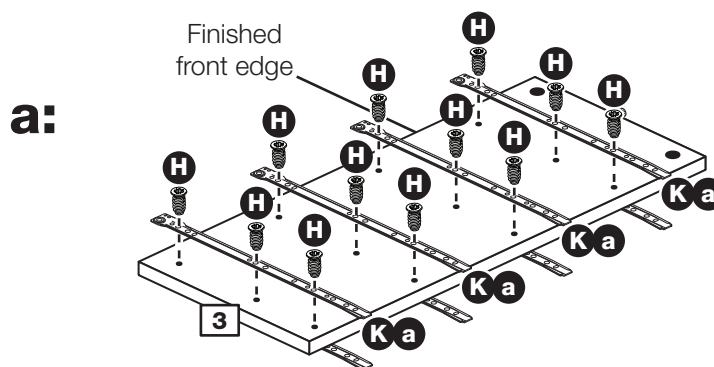
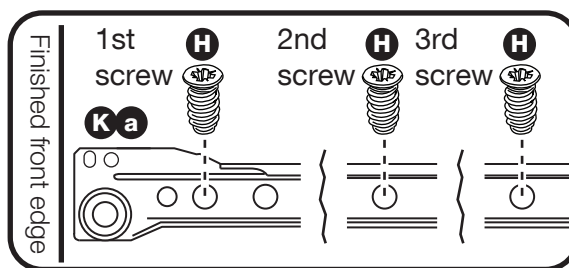

# Assembly Instructions

## Step 16

### Prepare the top

Screw 4 metal dowels **B** into the top **4**.

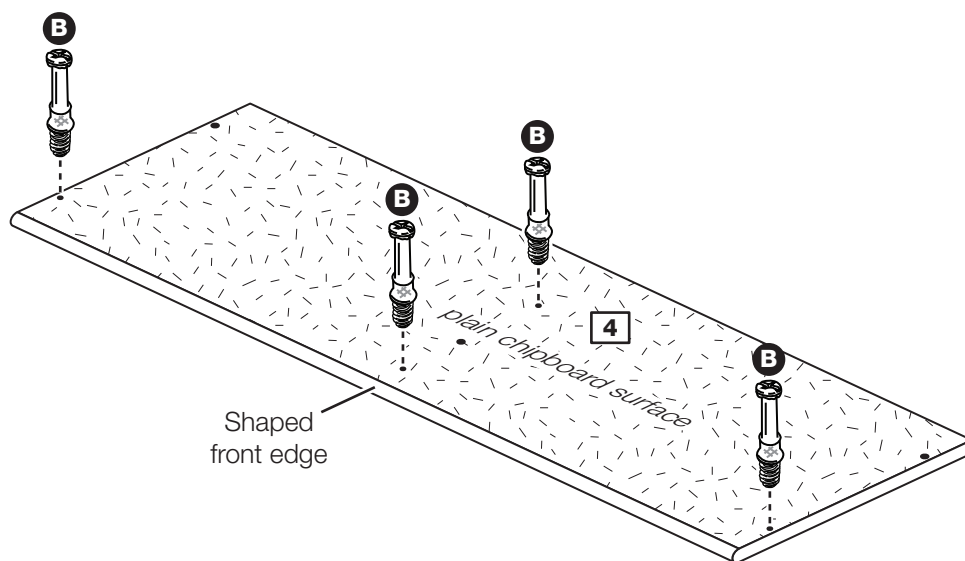

## Step 17

### Join the upright and top

Push the upright **3** onto the top **4**.

Use a screwdriver to tighten the 2 large locking nuts **D** fitted to the upright **3**.

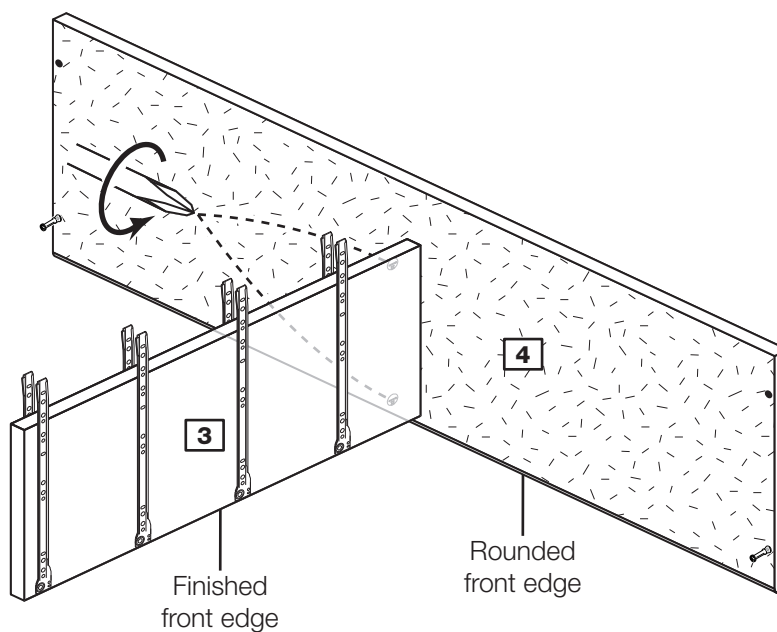

# Assembly Instructions

## Step 18

### Fit the top

*2 people are needed here*

Push the top **4** onto the 2 sides **1** and **2**.

Use a screwdriver to tighten the 2 large locking nuts **D** fitted to the sides **1** and **2**.

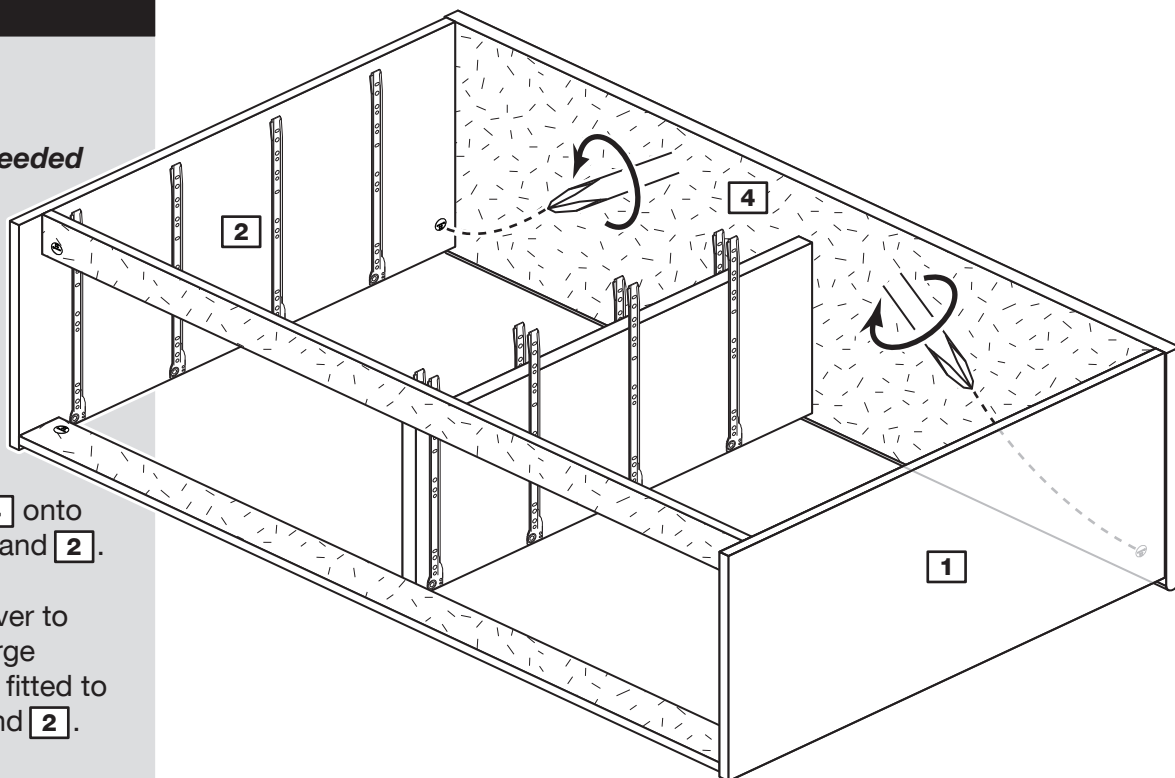

## Step 19

### Fit the back

**a:** Square up the unit by making sure that measurement **x to x** equals **y to y**.

**b:** Place the back **11** onto the unit.

Nail **F** around the outside edges of the back **11**.

**Note:** Nails should be spaced about 150mm apart.

**Using 2 people, carefully stand the unit up for the next step.**

**a:** The measurement from top corner X to bottom corner X must be equal to the measurement from top corner Y to bottom corner Y

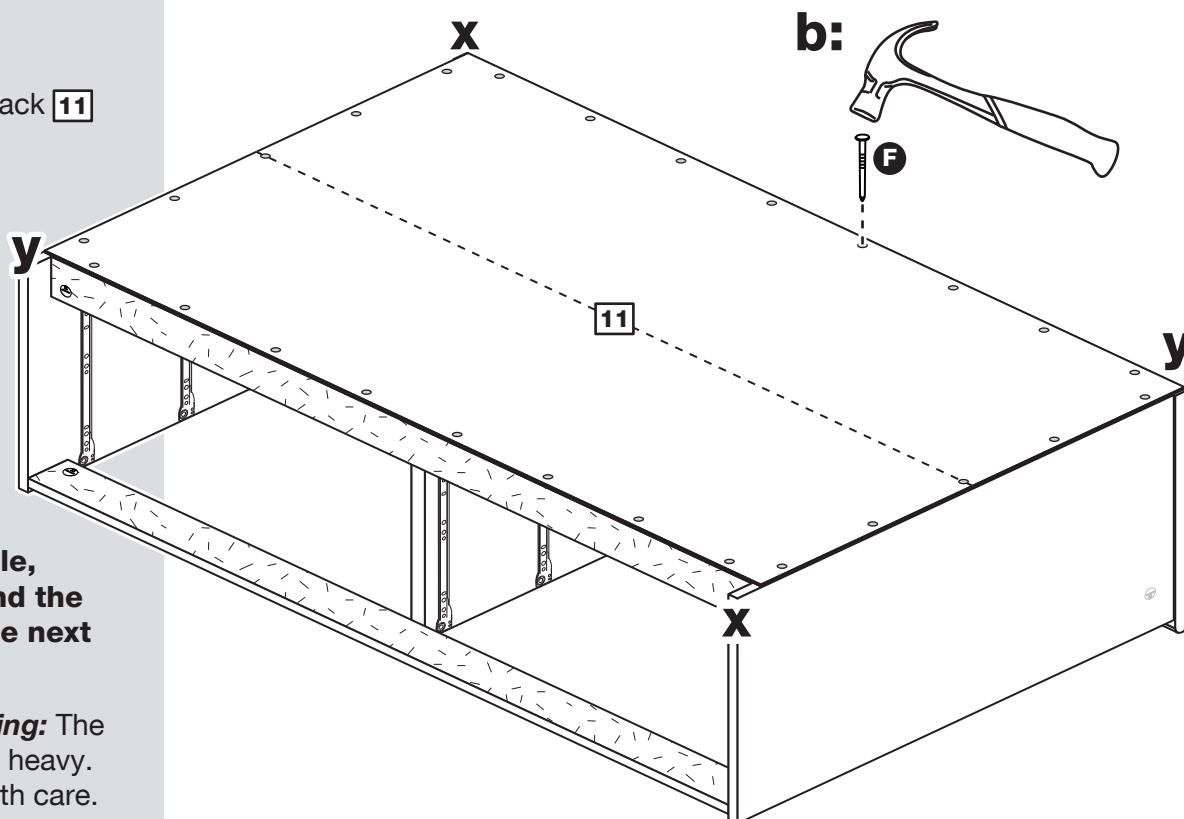

**Warning:** The unit is heavy. Lift with care.

# Assembly Instructions

## Step 20

### Fit the 4 plastic nails

Tap 2 plastic nails **M** into the bottom edge of each of the sides **1** and **2**.

Tap 1 plastic nail **M** into the bottom edge of the rail **6** in the centre.

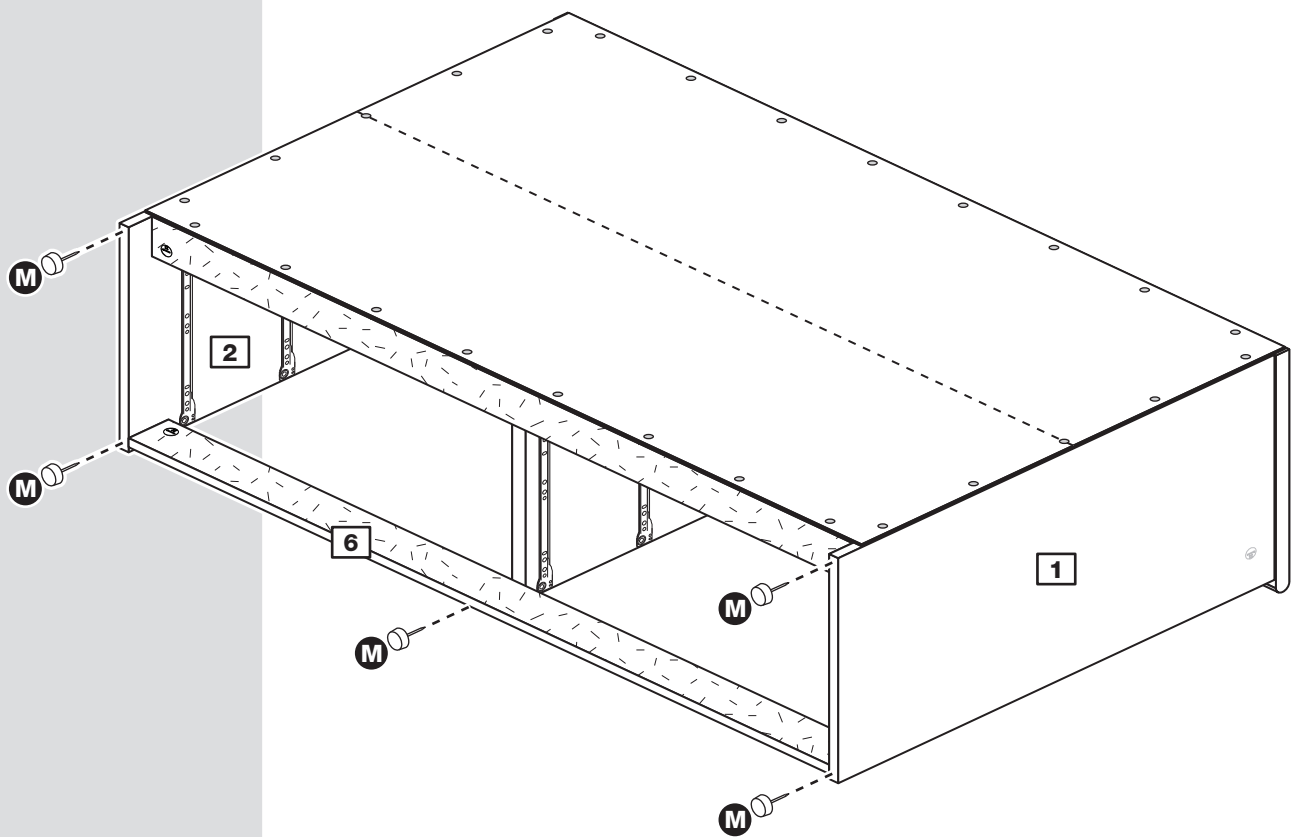

# Assembly Instructions

## Step 21

### Fit the drawers

Slide the wheels of the runners fitted to the drawers, over the wheels of the runners fitted to the side panels and push the drawers into position.

**Note:** We recommend that you fit the drawers in the sequence shown on the diagram.

### Assembly is complete



**Warning:** The unit is heavy. Lift with care.

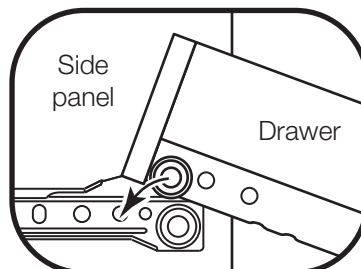
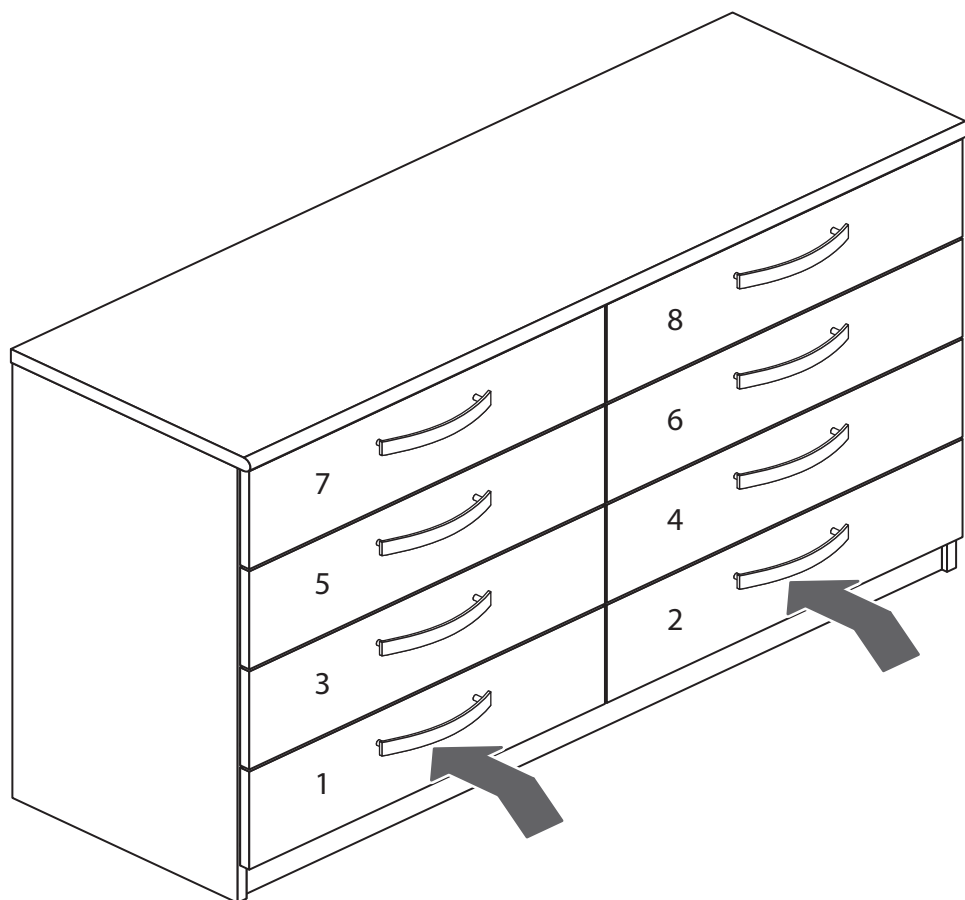

If you need help or have damaged or missing parts, call the **Customer Helpline: 0870 112 1928** or email: [Help@ClickSpares.co.uk](mailto:Help@ClickSpares.co.uk) (quoting your original order number and the reference numbers on the component pages)  
Argos Ltd, 489-499 Avebury Boulevard, Central Milton Keynes, MK9 2NW



# New Hallingford - 4+4 Drawer Chest

Assembly Instructions - Please keep for future reference

266/5508

258/6625

268/9577

262/1638

245/7510

272 825



## Dimensions

Width - 119.5cm

Depth - 40cm

Height - 74.5cm



**MADE IN  
BRITAIN**

**Important** - Please read these instructions fully before starting assembly

If you need help or have damaged or missing parts, call the **Customer Helpline: 0870 112 1928** or email: [Help@ClickSpares.co.uk](mailto:Help@ClickSpares.co.uk) (quoting your original order number)



# Safety and Care Advice

**Important - Please read these instructions fully before starting assembly**

- **Warning:** This unit weighs approximately 41.5kgs. Please lift with care.

- Check you have all the components and tools listed on pages 2 and 3.

- Remove all fittings from the plastic bags and separate them into their groups.

- Keep children and animals away from the work area, small parts could choke if swallowed.

- Parts of the assembly will be easier with 2 people.

- Make sure you have enough space to layout the parts before starting.

- Do not stand or put weight on the product, this could cause damage.

- Assemble the item as close to its final position (in the same room) as possible.

- Assemble on a soft level surface to avoid damaging the unit or your floor (use opened out unit carton).



- We do not recommend the use of power drill/drivers **for inserting screws**, as this could damage the unit. Only use hand screwdrivers.

- **Safety note:** If there is any chance of this unit being pulled over by children etc. it is recommended that the unit is secured to a wall using suitable fixings (not supplied).

- Dispose of all packaging carefully and responsibly.

## Care and maintenance

- Only clean using a damp cloth and mild detergent, do not use bleach or abrasive cleaners.

- From time to time check that there are no loose screws on this unit.

- This product should not be discarded with household waste. Take to your local authority waste disposal centre.

**Note:** If required the next page can be cut out and used as reference throughout the assembly. Keep this page with these instructions for future reference.

# Components - Panels

If you have damaged or missing components, call the **Customer Helpline: 0870 112 1928** or email: **Help@ClickSpares.co.uk** (quoting your original order number and the reference numbers below)

Please check you have all the panels listed below

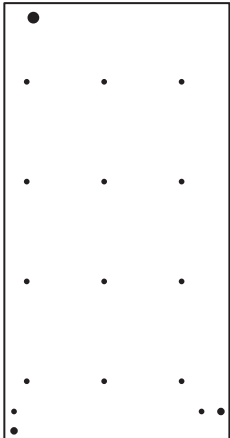

**1** Left Side (D2312A)  
(721 x 372mm)

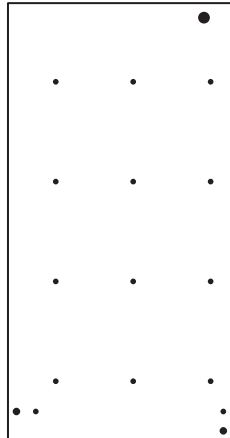

**2** Right Side (D2313A)  
(721 x 372mm)



**3** Upright (D2323A)  
(655 x 282mm)

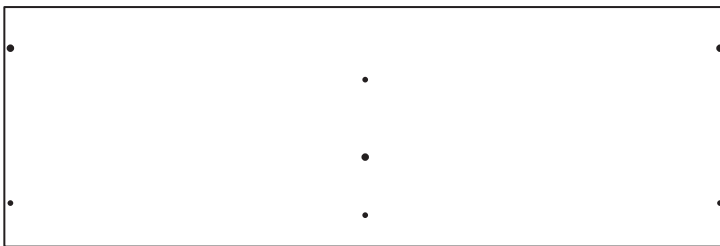

**4** Top (D2322A)  
(1193 x 396mm)

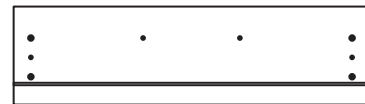

**5** Drawer Front (D2324A)  
(588 x 162mm) x 8



**6** Rail (D2325A)  
(1158 x 66mm) x 2



**7** Drawer Base (T529-367)  
(529 x 367mm) x 8



**8** Left Drawer Side (W370-124LH)  
(370 x 124mm) x 8



**9** Right Drawer Side (W370-124RH)  
(370 x 124mm) x 8



**10** Drawer Back (W518-124)  
(518 x 124mm) x 8

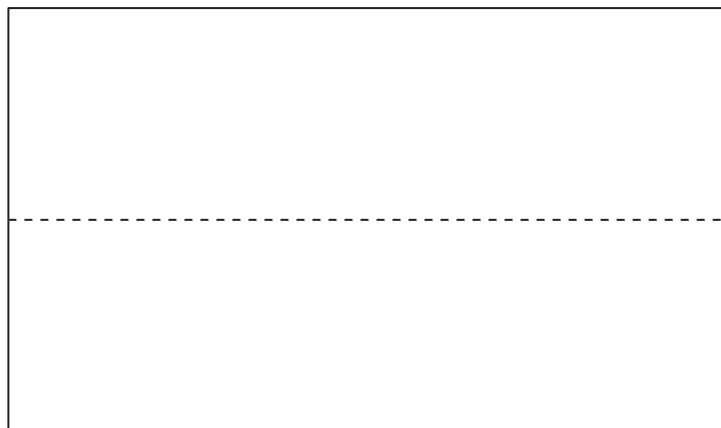

**11** Back (X1184-700)  
(1184 x 700mm)











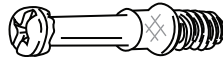



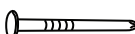

# Components - Fittings

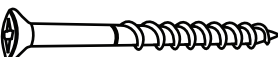
If you have damaged or missing components, call the **Customer Helpline: 0870 112 1928** or **email: Help@ClickSpares.co.uk** (quoting your original order number and the reference numbers below)

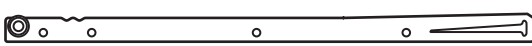
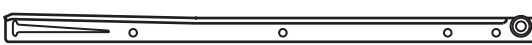
Please check you have all the fittings listed below

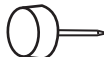
**Note:** The quantities below are the correct amount to complete the assembly. In some cases more fittings may be supplied than are required.

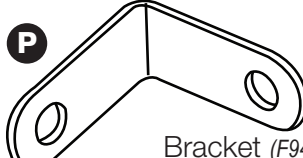
<p><b>A</b> </p> <p>Wooden dowel (F22) x 7</p>	<p><b>B</b> </p> <p>Metal dowel (F901) x 24</p>	<p><b>C</b> </p> <p>Small locking nut (F3) x 16</p>	
<p><b>D</b> </p> <p>Large locking nut (F900) x 8</p>	<p><b>E</b> </p> <p>Knock-in Peg (F171GY) x 32</p>	<p><b>F</b> </p> <p>Nail (F51) x 26</p>	
<p><b>G</b> </p> <p>19mm Screw (F461) x 16</p>	<p><b>H</b> </p> <p>13mm Screw (F52) x 48</p>	<p><b>I</b> </p> <p>13mm Screw (F63) x 48</p>	<p><b>J</b> </p> <p>13mm Screw (F79) x 1</p>
<p><b>K</b> </p> <p>45mm Screw (F65) x 1</p>	<p><b>L a</b>  L Runner (F159) x 8            ← 350mm long →</p> <p><b>L b</b>  R Runner (F160) x 8</p> <p><b>L c</b>  L Runner (F161) x 8</p> <p><b>L d</b>  R Runner (F162) x 8</p>		
<p><b>M</b> </p> <p>Wedgex (F639) x 32</p>	<p><b>N</b> </p> <p>Plastic Nail (F91) x 5</p>		
<p><b>O</b> </p> <p>Handle (F278) x 8</p>		<p><b>P</b> </p> <p>Bracket (F945) x 1</p>	

## Tools required



Rule



Cross-head screwdriver



Scissors



Hammer



Eye protection (when using a hammer or drill)



Electric drill (do not use for fitting screws)

**Ruler** - Use this ruler to help correctly identify the screws

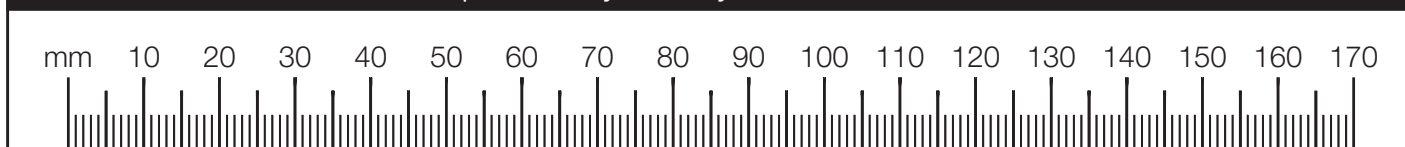

# Assembly Instructions

If you have damaged or missing components, call the Customer Helpline: 0870 112 1928 or email: [Help@ClickSpares.co.uk](mailto:Help@ClickSpares.co.uk) (quoting your original order number and the reference numbers below)

## Step 1

### Prepare the drawer fronts

Screw 2 metal dowels **B** into the holes shown on the back of each drawer front **5**.

**Note:** Tighten the metal dowels up fully against the panels.

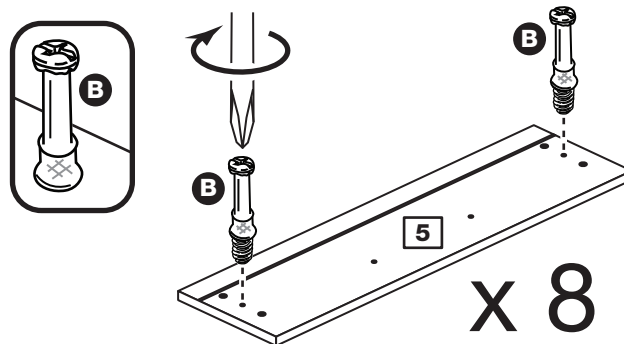

## Step 2

### Prepare the drawer sides

Insert a small locking nut **C** into the hole shown on the left drawer side **8** and right drawer side **9**.

**Note:** The arrow on the locking nut **must** point towards the hole in the edge of the panel.

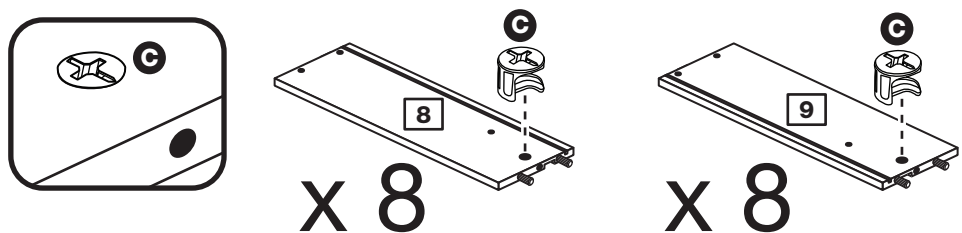

## Step 3

### Attach the drawer sides to the drawer front

Push the left drawer side **8** and right drawer side **9** onto the back of the drawer front **5**.

Turn the small locking nuts **C** on the left drawer side **8** and right drawer side **9**.

**Note:** Turn the locking nuts **C** clockwise to secure panels - more than 1/2 a turn.

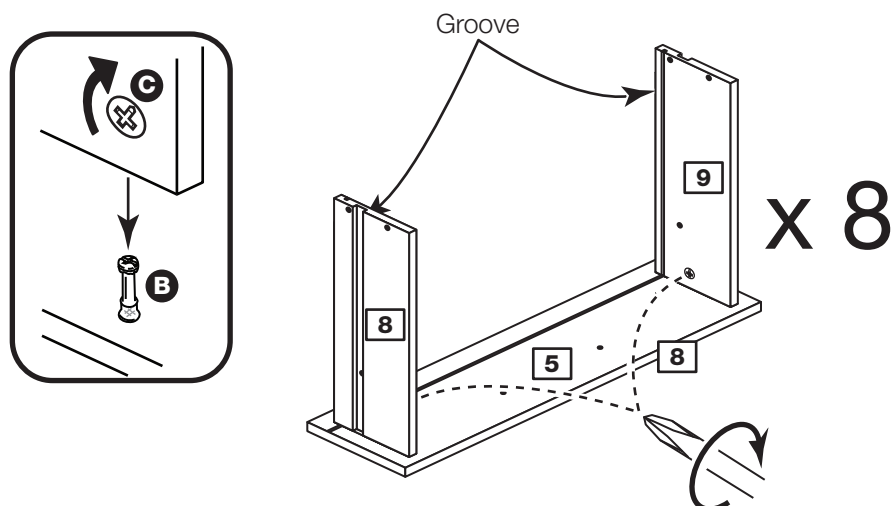

**Note:** The locking nuts can be on either surface of the drawer sides. Make sure that the groove is on the inside, as shown.

# Assembly Instructions

## Step 4

### Fit the drawer base

Slide the drawer base **7** down the grooves in the drawer sides **8** and **9** and down into the groove in the drawer front **5**.

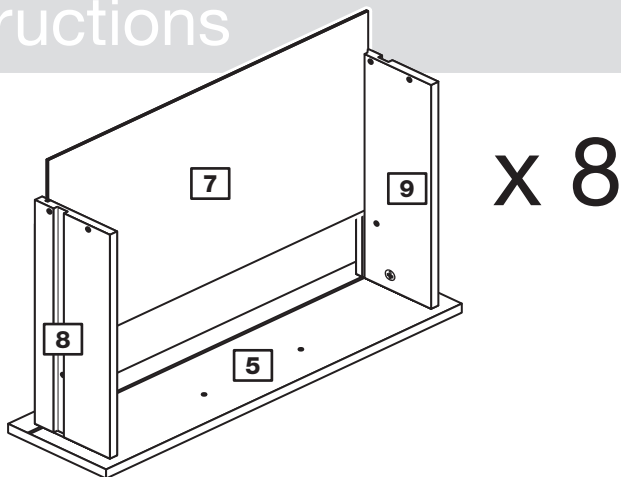

## Step 5

### Fit the drawer back

Fit the drawer back **10** between the drawer sides **8** and **9**.

Make sure that the drawer base **7** fits into the groove in the drawer back **10**.

Hold the drawer back **10** in position and tap the knock-in pegs **E** through the holes in the drawer sides **8** and **9**.

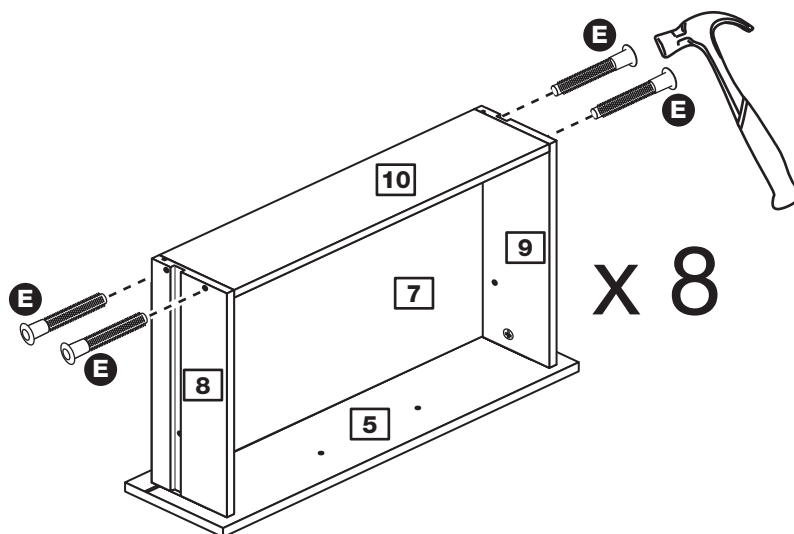

## Step 6

### Attach the handles

Attach a handle **O** to each drawer front **5** using 2 screws **G**.

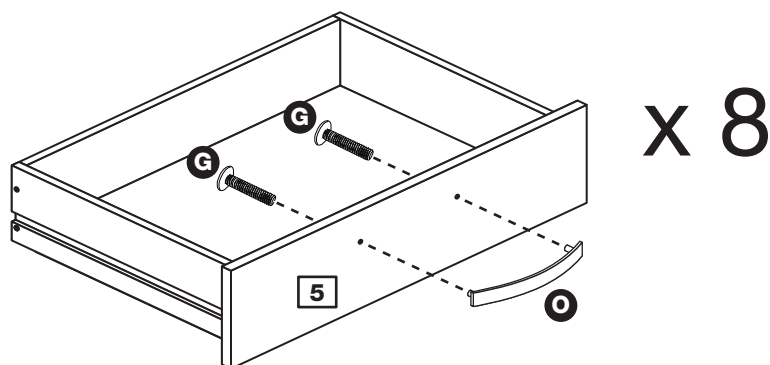

## Step 7

### Fit the wedgexes

Turn the drawer assemblies over and slide 4 wedgexes **M** into the front and back grooves, as shown, and tighten up the screws.

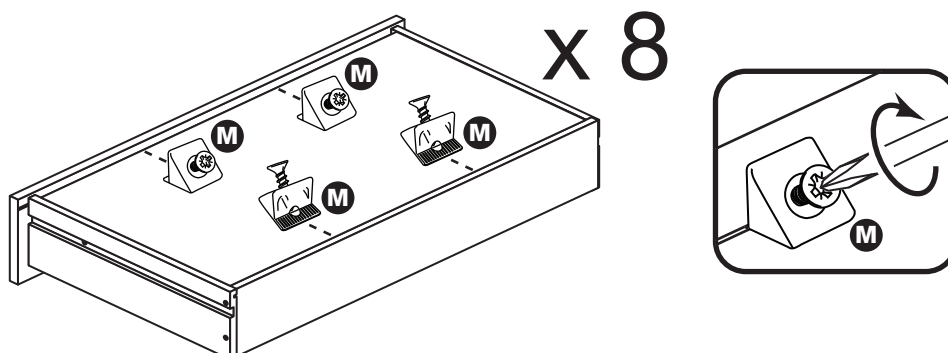

# Assembly Instructions

## Step 8

### Fit runners to the drawers

Fit runner **Ld**, marked with 'R', to the bottom edge of the right drawer side **9**, as shown, making sure that it is pushed up against the back of the drawer front **5**.

Use a bradawl to mark the fixing positions, then secure with 2 screws **I**.

Fit runner **Lc**, marked 'L', to the bottom edge of the left drawer side **8** using the same method.

Runners must be pushed up against the drawer front

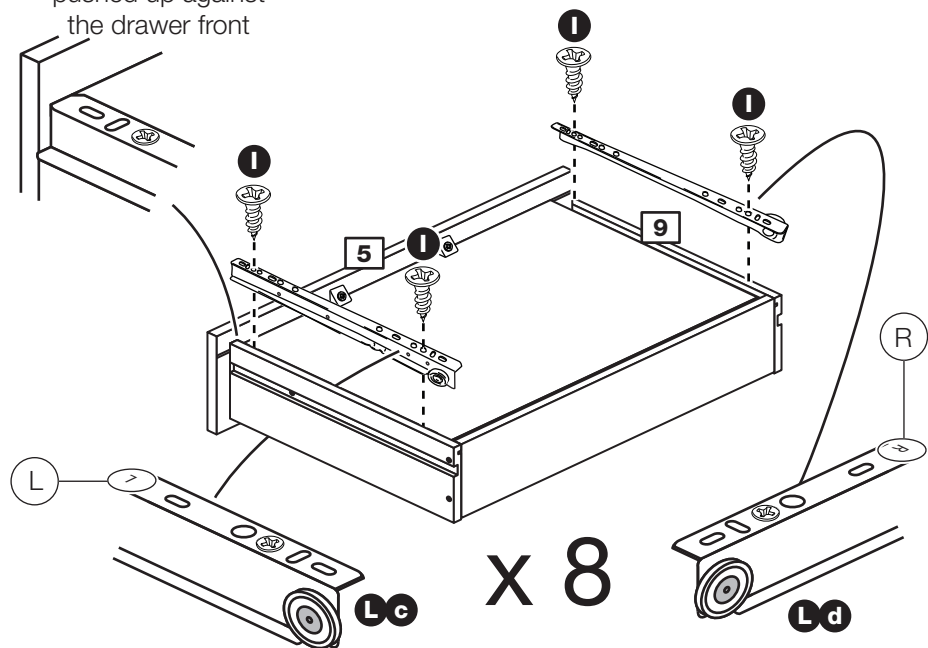

## Step 9

### Prepare the 2 rails

Tap 2 wooden dowels **A** into each rail **6**.

**Note:** Wooden dowels **must not** stick out from the edge by more than 10mm or they may damage other panels.

Insert 2 large locking nuts **D** into each rail **6**.

**Note:** The arrow on the locking nut **must** point towards the hole in the edge of the panel.

Fit the bracket **P** to the mark hole in the middle of 1 of the **6** rails using screw **J**.

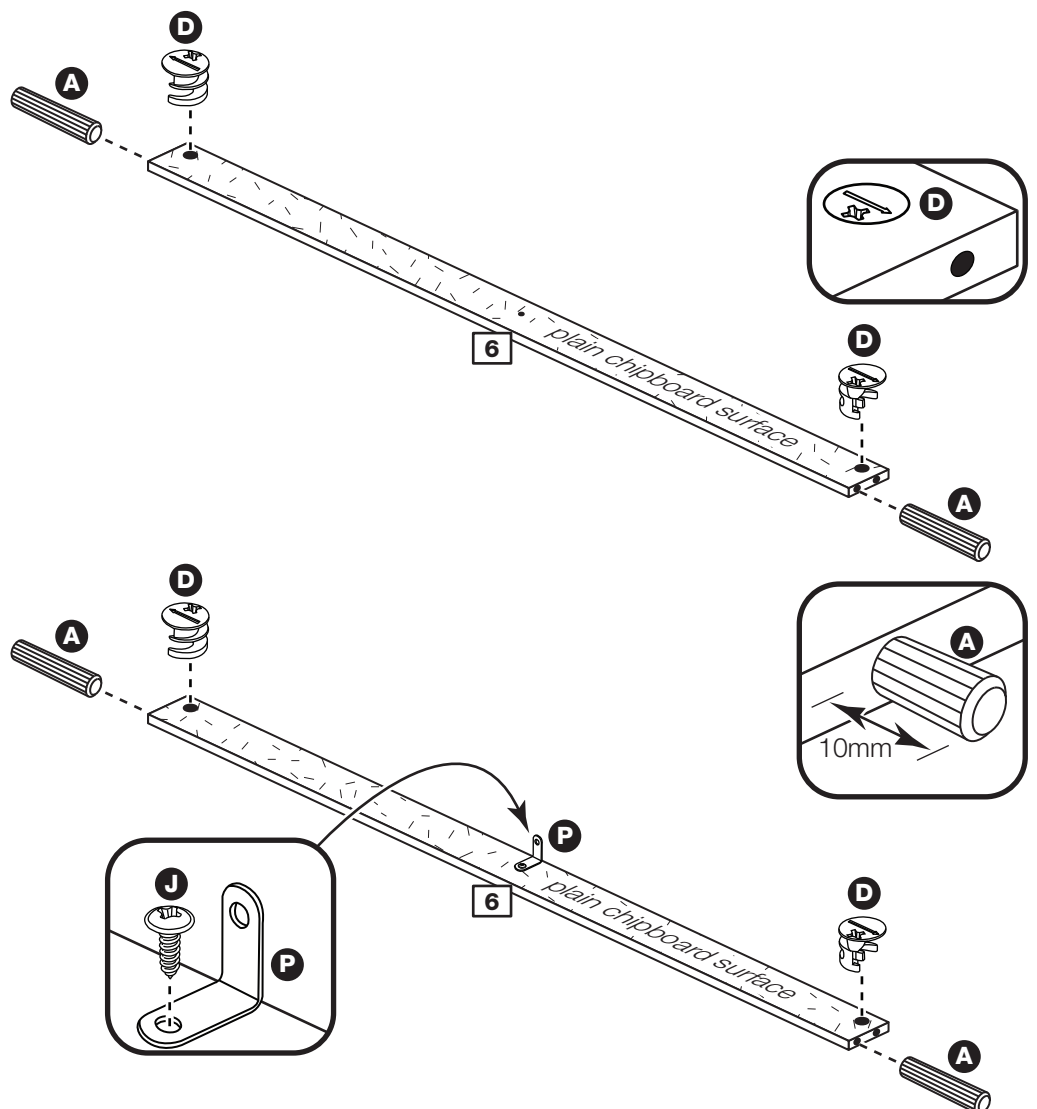

# Assembly Instructions

## Step 10

### Prepare the left side

**a:** Fit 4 runners **L a** to the left side **1**.

The 1st screw **H** uses the 2nd hole in from the front of the runner.

The 2nd and 3rd screws **H** use the holes that line up with the other panel holes.

**b:** Fit a screw **I** into the 2nd hole in at the top of the runners **L a**.

Screw 2 metal dowels **B** into the left side **1**.

Insert a large locking nut **D** into the left side **1**.

**Note:** The arrow on the locking nut **must** point towards the hole in the edge of the panel.

Tap a wooden dowel **A** into the left side **1**.

**Note:** Wooden dowels **must not** stick out from the edge by more than 10mm or they may damage other panels.

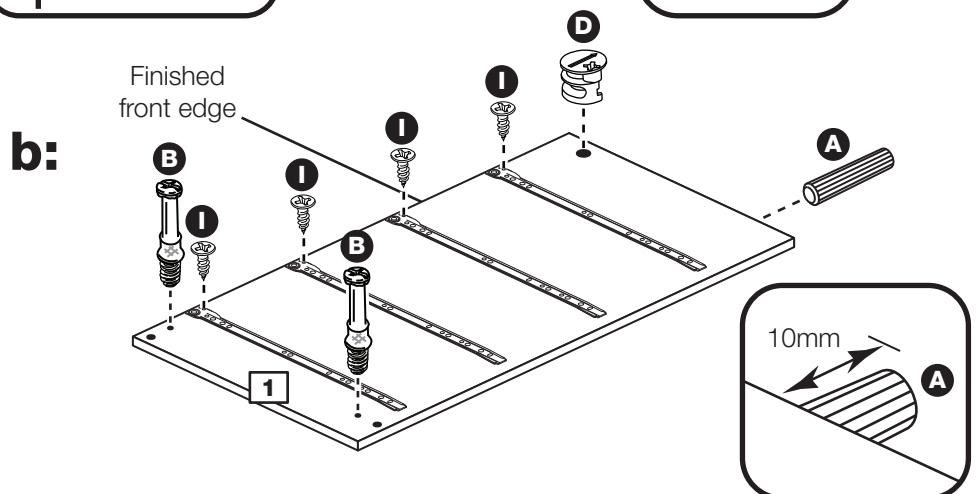
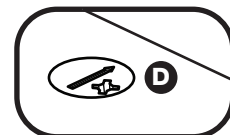
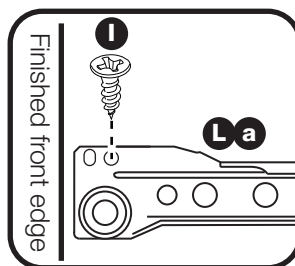
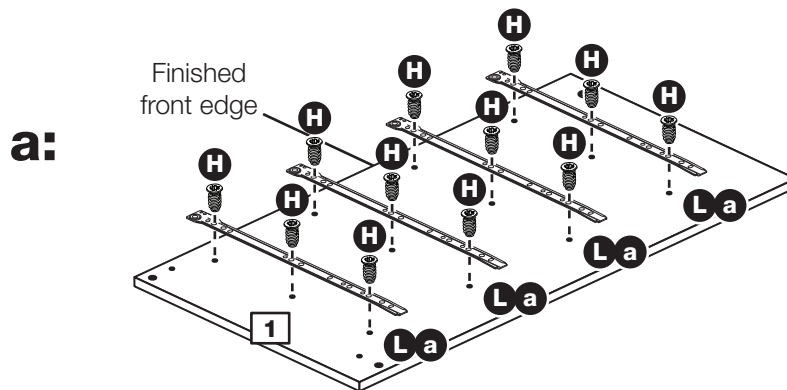
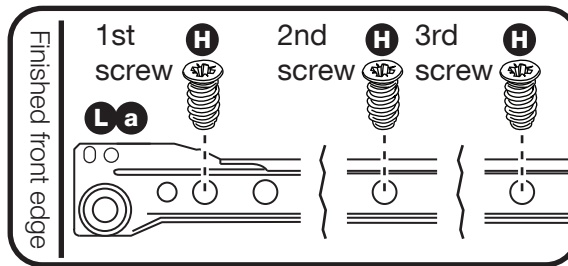



# Assembly Instructions

## Step 11

### Prepare the right side

**a:** Fit 4 runners **Lb** to the right side **2**.

The 1st screw **H** uses the 2nd hole in from the front of the runner.

The 2nd and 3rd screws **H** use the holes that line up with the other panel holes.

**b:** Fit a screw **I** into the 2nd hole in at the top of the runner **Lb**.

Screw 2 metal dowels **B** into the right side **2**.

Insert a large locking nut **D** into the right side **2**.

Tap a wooden dowel **A** into the right side **2**.

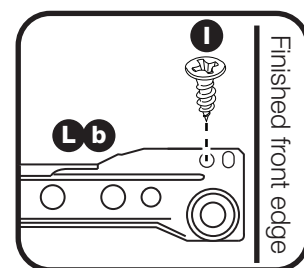
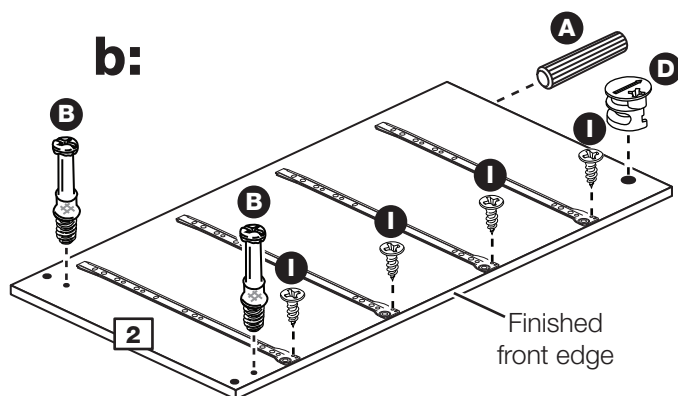
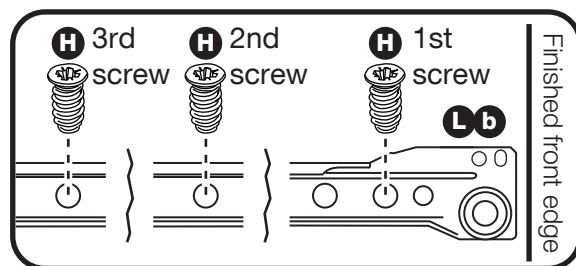
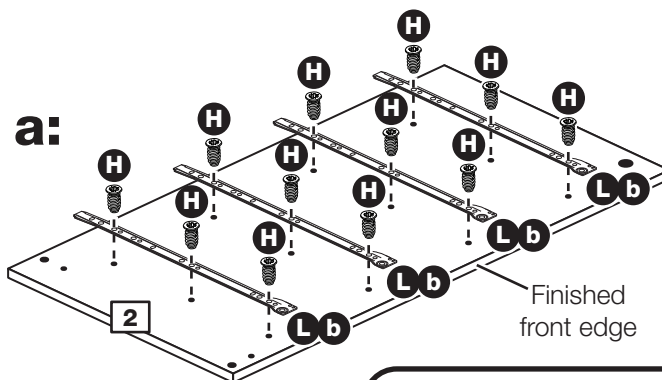

# Assembly Instructions

## Step 12

### Join the right side and rails

*2 people are needed here*

Push the 2 rails **6** onto the right side **2**.

Use a screwdriver to tighten the 2 large locking nuts **D** fitted to the rails **6**.

**Note:** Turn the large locking nuts **D** as far as they will go - more than 1/2 a turn.

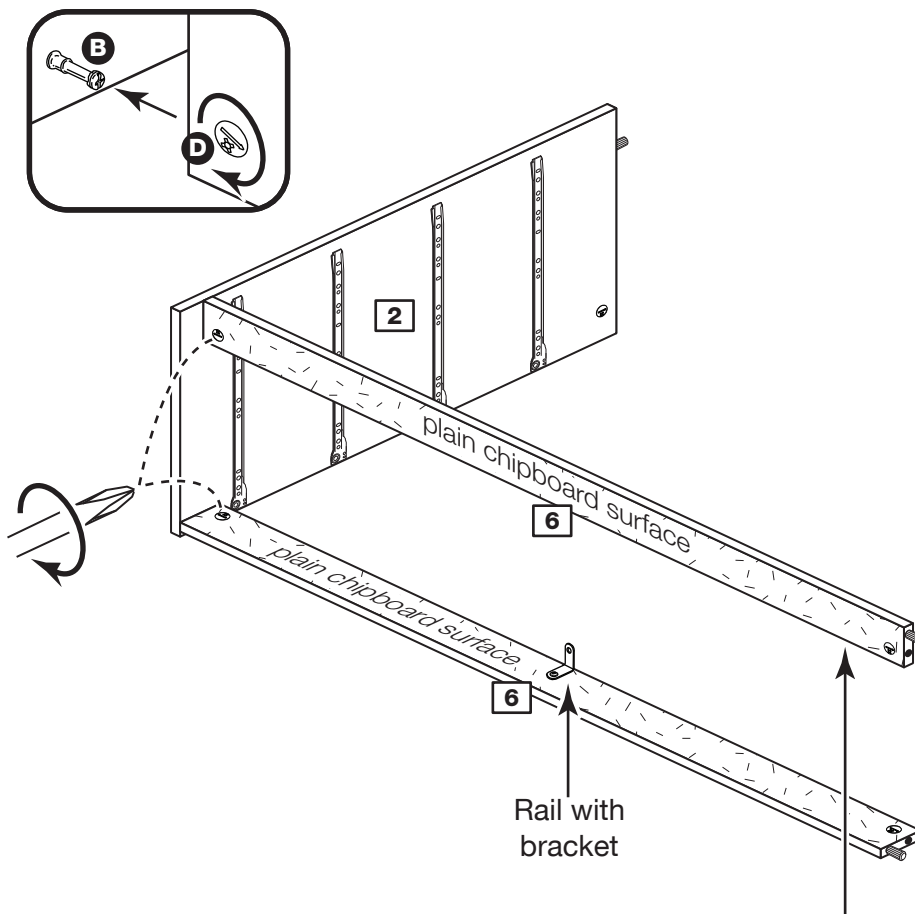

**Note:** Support this rail until the left side has been fitted in the next step.

## Step 13

### Fit the left side

Push the left side **1** onto the 2 rails **6**.

Use a screwdriver to tighten the 2 large locking nuts **D** fitted to the rails **6**.

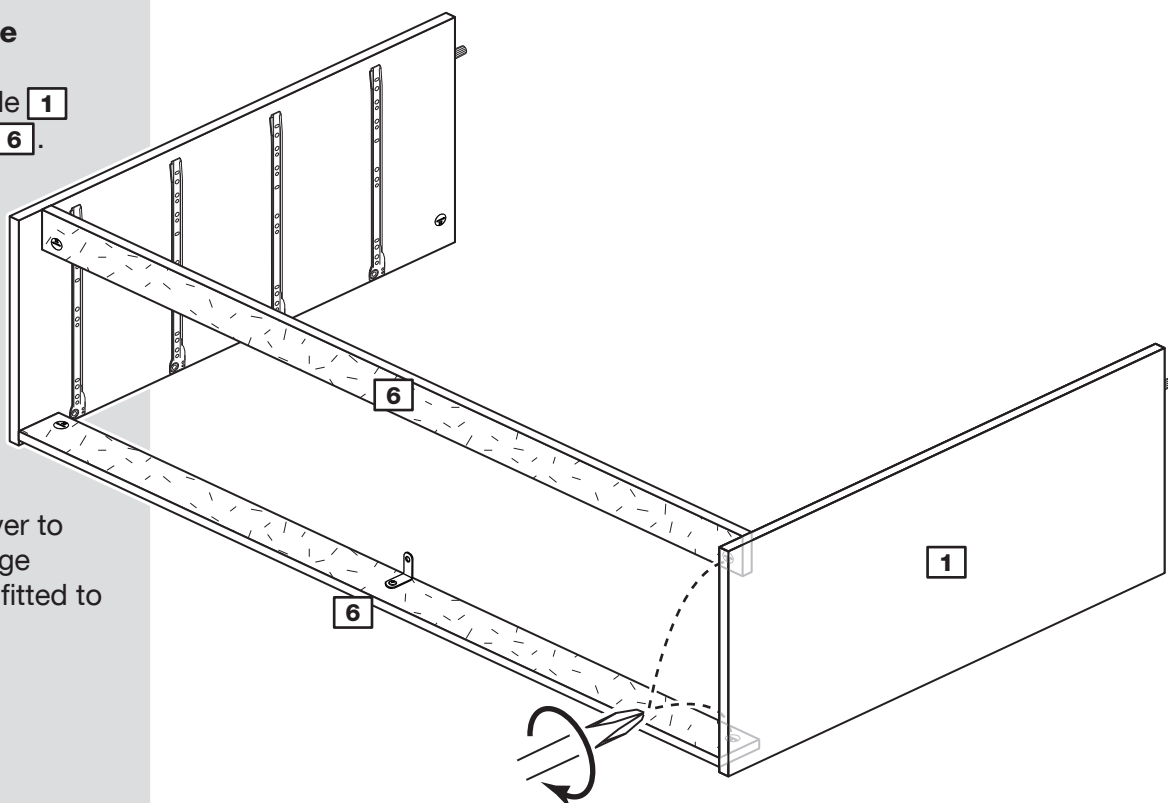

# Assembly Instructions

## Step 14

### Prepare the first surface of the upright

**Note:** The colour of the upright may differ from the main unit colour.

**a:** Fit 4 runners **Lb** to the upright **3**.

The 1st screw **H** uses the 2nd hole in from the front of the runner.

The 2nd and 3rd screws **H** use the holes that line up with the other panel holes.

**b:** Fit a screw **I** into the 2nd hole in at the top of the runner **Lb**.

Tap a wooden dowel **A** into the upright **3**.

**Turn the upright over for the next step**

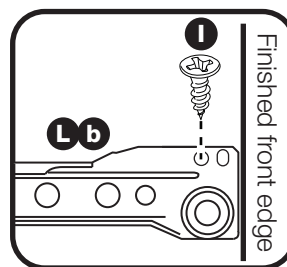
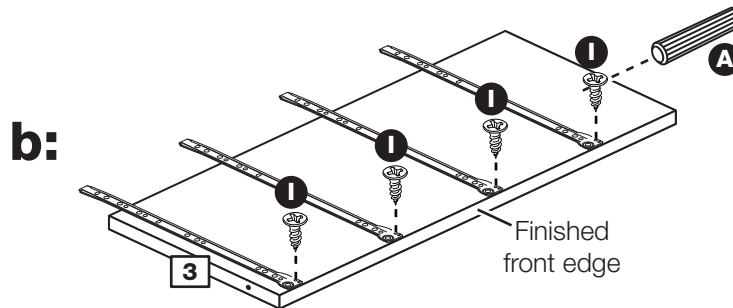
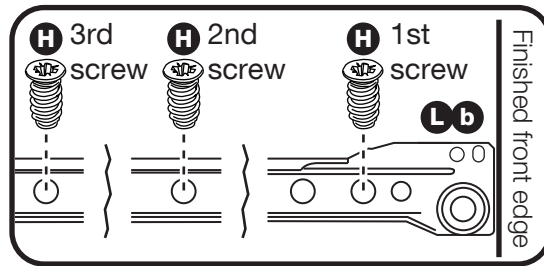
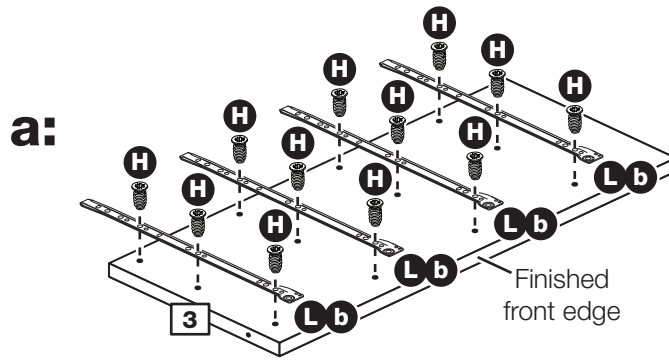

**Turn the divider over**

# Assembly Instructions

## Step 15

### Prepare the other surface of the upright

**a:** Fit 4 runners **La** to the upright **3**.

The 1st screw **H** uses the 2nd hole from the front of the runner.

The 2nd and 3rd screws **H** use the holes that line up with the other panel holes.

**b:** Fit a screw **I** into the 2nd hole in at the top of the runner **La**.

Insert 2 large locking nuts **D** into the upright **3**.

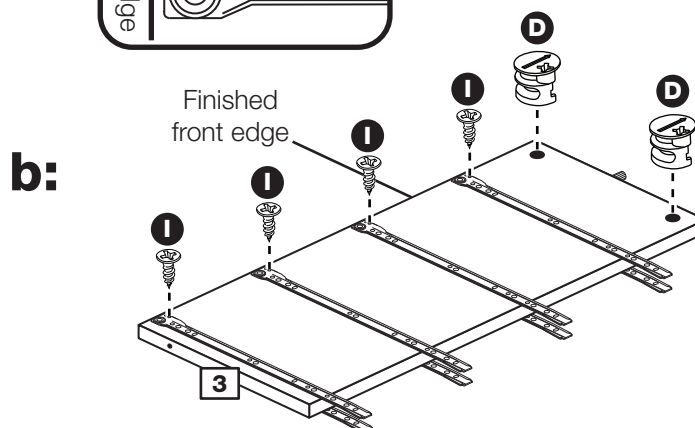
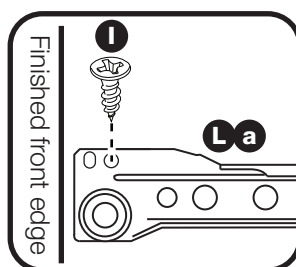
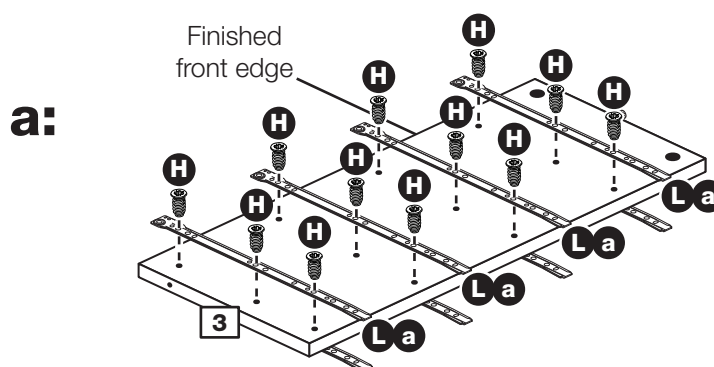
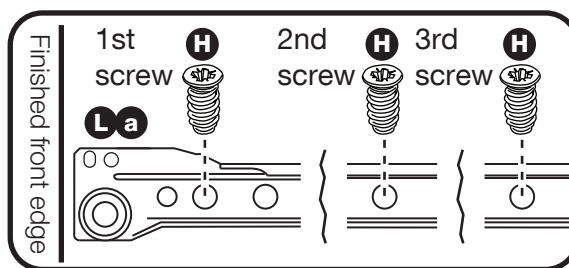

# Assembly Instructions

## Step 16

### Prepare the top

Screw 4 metal dowels **B** into the top **4**.

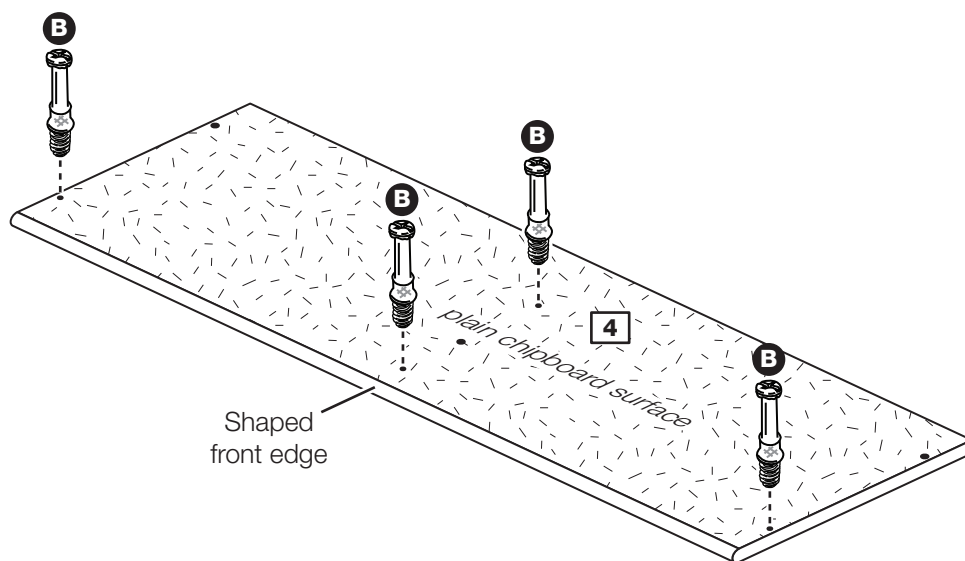

## Step 17

### Join the upright and top

Push the upright **3** onto the top **4**.

Use a screwdriver to tighten the 2 large locking nuts **D** fitted to the upright **3**.

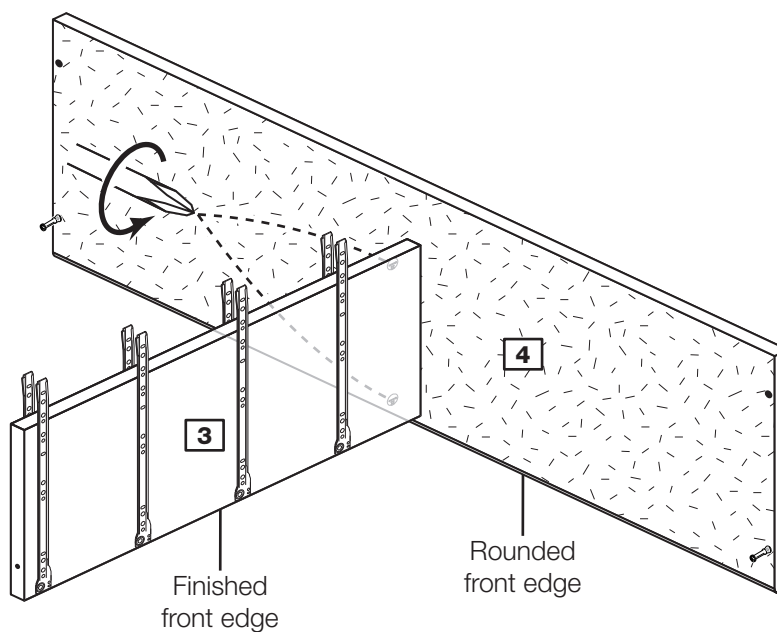

# Assembly Instructions

## Step 18

### Fit the top

Push the top **4** onto the 2 sides **1** and **2**.

Use a screwdriver to tighten the 2 large locking nuts **D** fitted to the sides **1** and **2**.

Line up the hole in the bottom of the upright **3** with the bracket **P** and secure it using screw **K**.

2 people are needed here

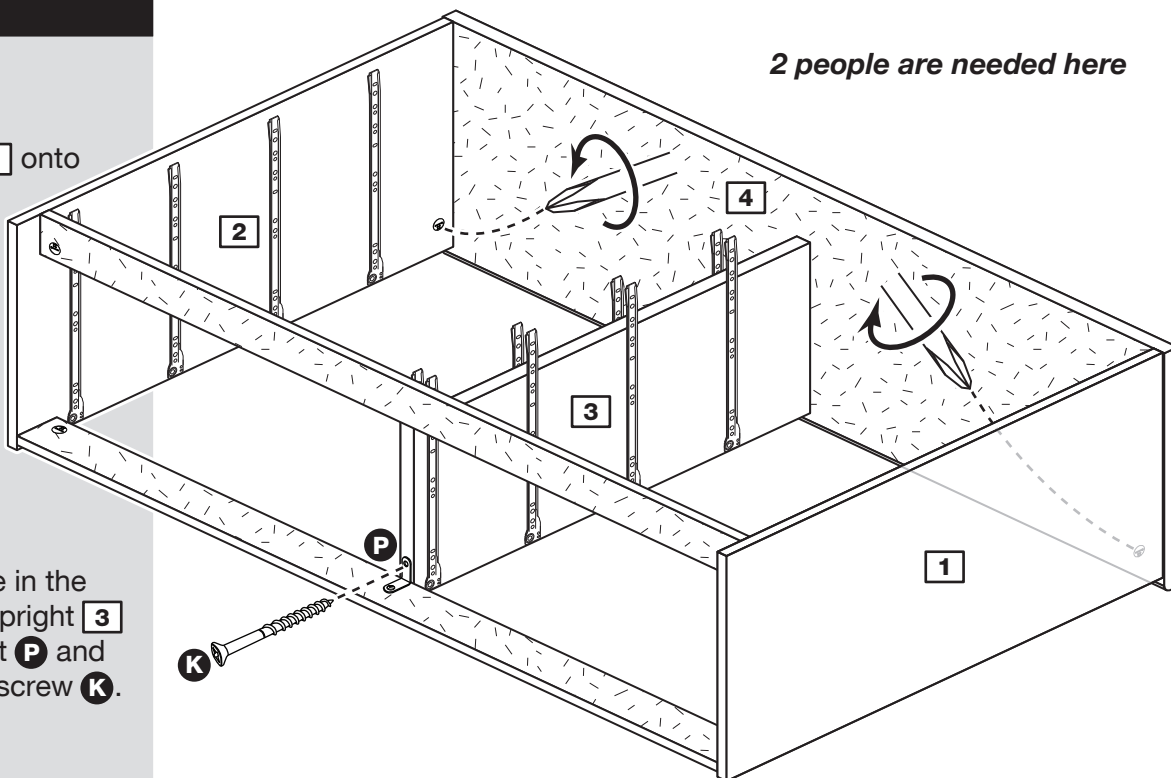

## Step 19

### Fit the back

**a:** Square up the unit by making sure that measurement **x to x** equals **y to y**.

**b:** Place the back **11** onto the unit.

Nail **F** around the outside edges of the back **11**.

**Note:** Nails should be spaced about 150mm apart.

**Using 2 people, carefully stand the unit up for the next step.**

**a:** The measurement from top corner X to bottom corner X must be equal to the measurement from top corner Y to bottom corner Y

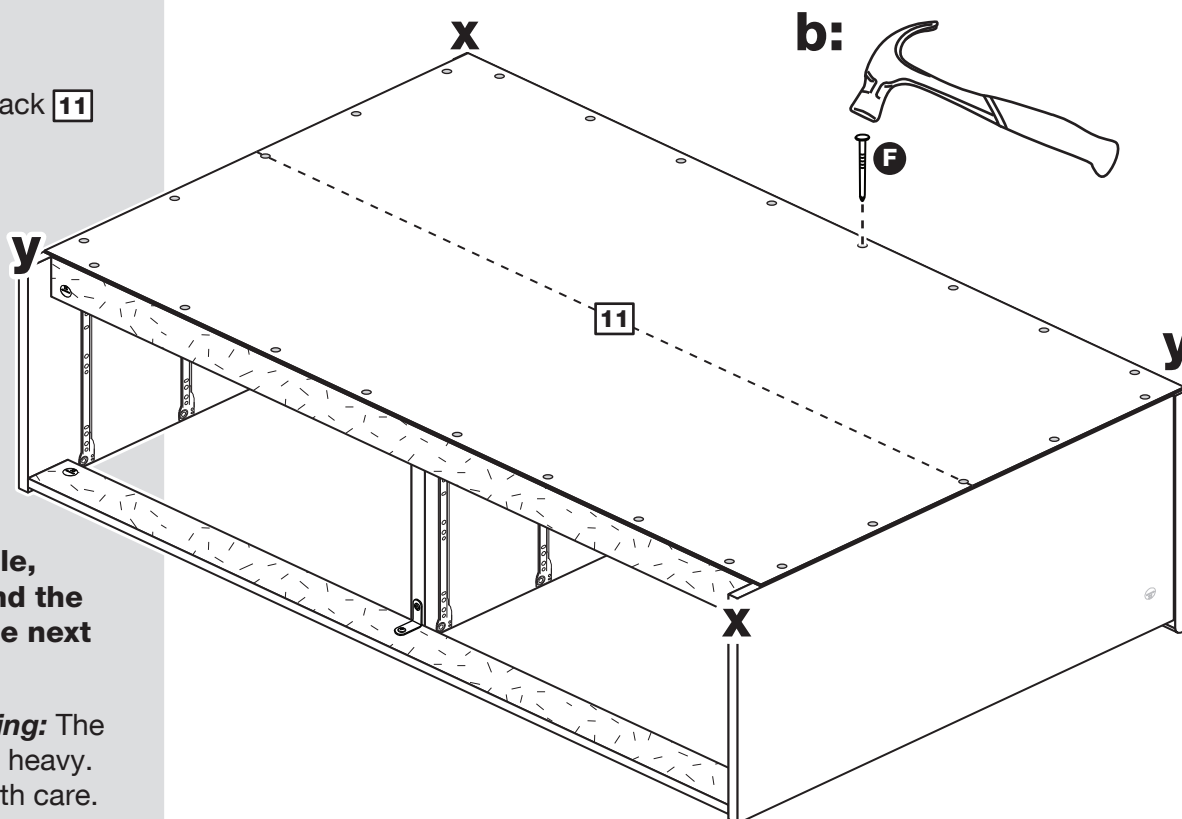

**Warning:** The unit is heavy. Lift with care.

# Assembly Instructions

## Step 20

### Fit the 4 plastic nails

Tap 2 plastic nails **N** into the bottom edge of each of the sides **1** and **2**.

Tap 1 plastic nail **N** into the bottom edge of the rail **6** in the centre.

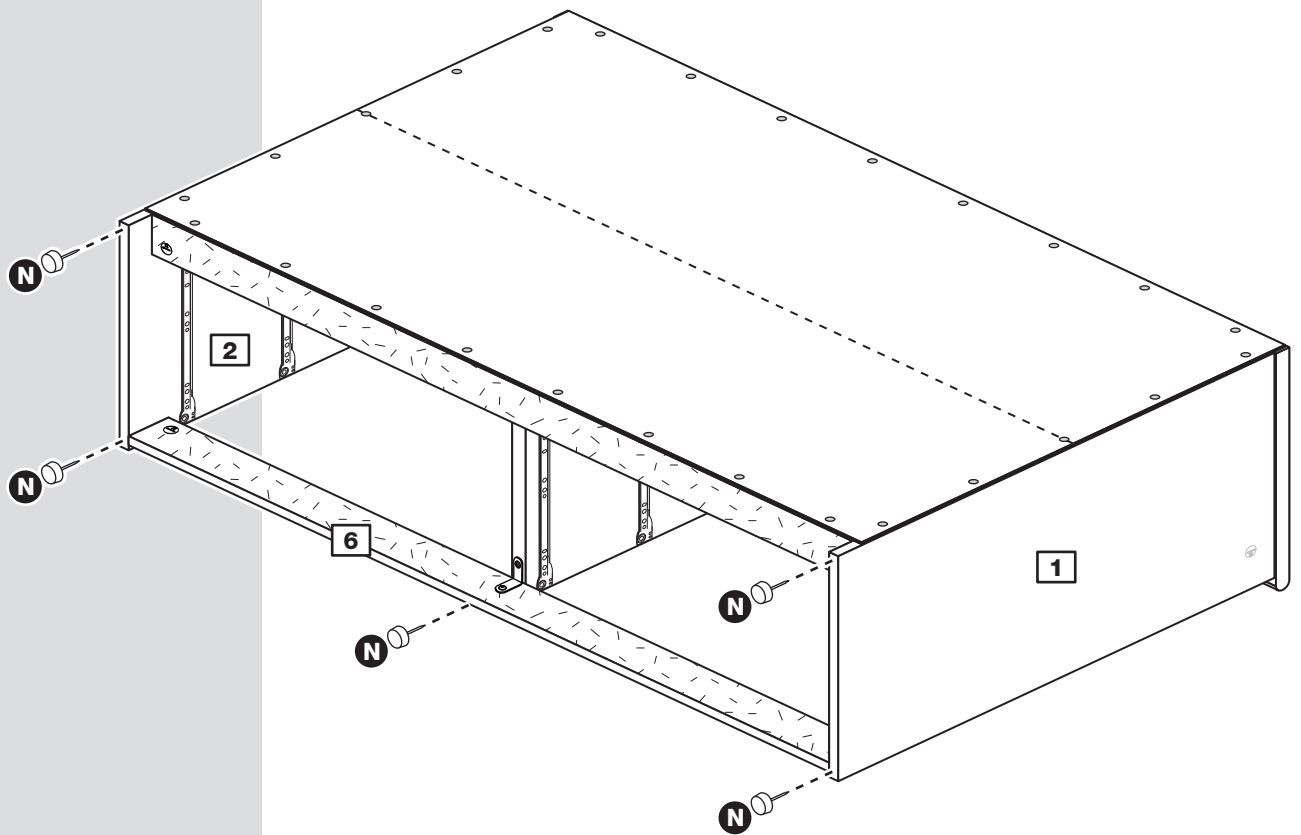

# Assembly Instructions

## Step 21

### Fit the drawers

Slide the wheels of the runners fitted to the drawers, over the wheels of the runners fitted to the side panels and push the drawers into position.

**Note:** We recommend that you fit the drawers in the sequence shown on the diagram.

### Assembly is complete



**Warning:** The unit is heavy. Lift with care.

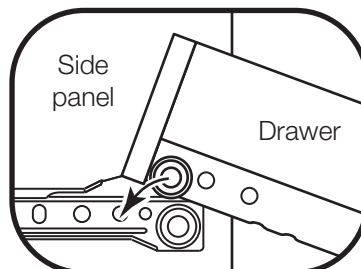
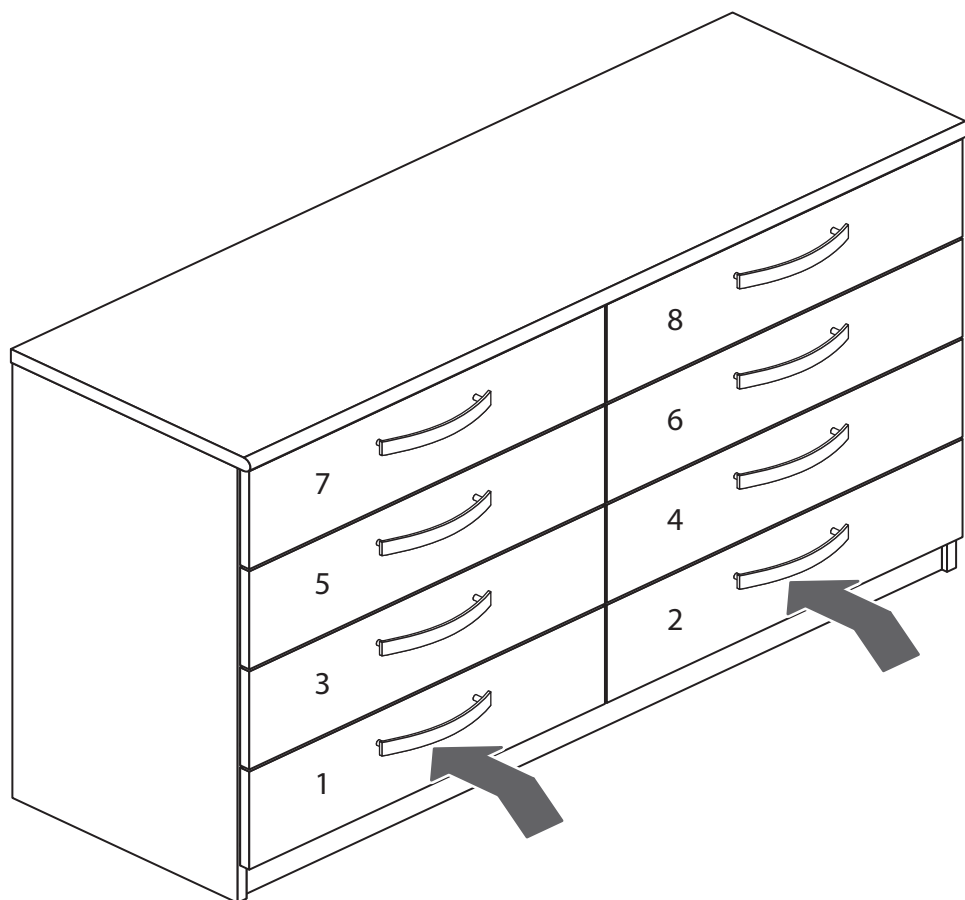

If you need help or have damaged or missing parts, call the **Customer Helpline: 0870 112 1928** or email: [Help@ClickSpares.co.uk](mailto:Help@ClickSpares.co.uk) (quoting your original order number and the reference numbers on the component pages)  
Argos Ltd, 489-499 Avebury Boulevard, Central Milton Keynes, MK9 2NW



# New Hallingford 3 Door 3 Drawer Wardrobe

Assembly Instructions - Please keep for future reference

2278380

2745253

2749716

2482279

2448282

**Tip : To prevent damage,  
we recommend that you  
build your unit on the  
carton(s) it was packed in.**

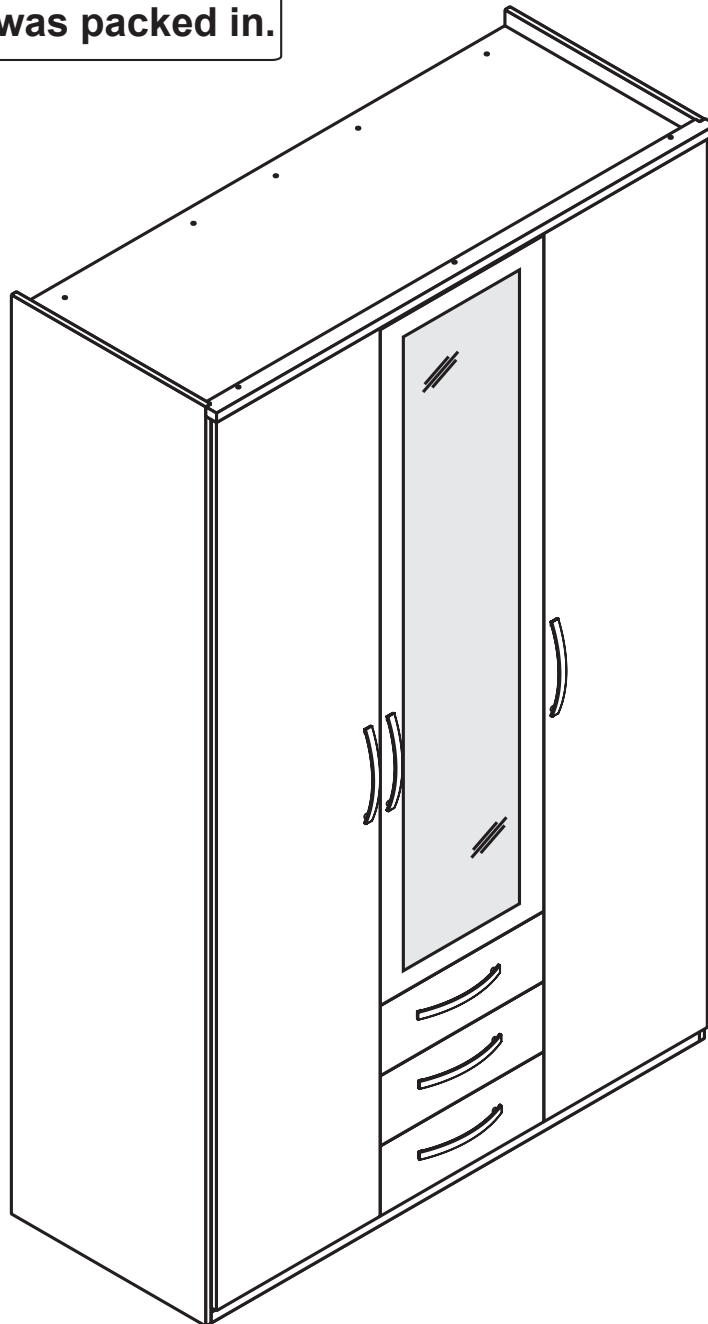

## Dimensions

Width - 148,8cm

Depth - 60,3cm

Height - 205,7cm

**Important - Please read these instructions before starting assembly**

If you need help or have damaged or missing parts, call the **Customer Helpline:**  
**03456 400 800**



# Safety and Care Advice

**Important** – Please read these instructions fully before starting assembly

- Check you have all the components and tools listed on pages 2 and 3.
- Remove all fittings from the plastic bags and separate them into their groups.
- Keep children and animals away from the work area, small parts could choke if swallowed.
- Make sure you have enough space to layout the parts before starting.

- Do not stand or put weight on the product, this could cause damage.
- Assemble the item as close to its final position (in the same room) as possible.
- Assemble on a soft level surface to avoid damaging the unit or your floor.
- Parts of the assembly will be easier with 2 people.



power drill is set on a low torque setting

- To reduce the likelihood of damaging your product please ensure that your
- Dispose of all packaging carefully and responsibly.

## Care and maintenance

- Only clean using a damp cloth and mild detergent, do not use bleach or abrasive cleaners.
- From time to time check that there are no loose screws on this unit.
- This product should not be discarded with household waste. Take to your local authority waste disposal centre.

**Note:** if required the next page can be cut out and used as reference throughout the assembly. Keep this page with these instructions for future reference.

# Components - Panels

If you have damaged or missing components, call the Customer Helpline: 03456 400 800

Please check you have all the panels listed below

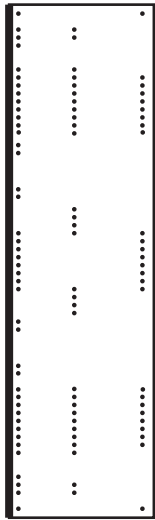

**1** Left side  
(205.6 x 58cm)  
P2349b

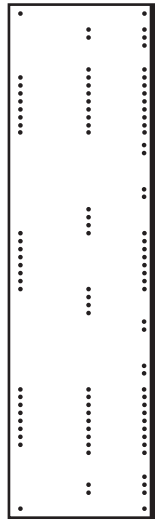

**2** Right side  
(205.6 x 58cm)  
P2349b

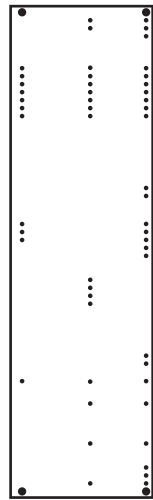

**3** Upright  
(196.9 x 57.6cm)  
P2354b



**4** Door x 2  
(199.2 x 48.8cm)  
P3304

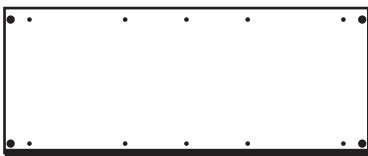

**5** Top/Bottom x 2  
(145.8 x 57.7cm)  
P1350

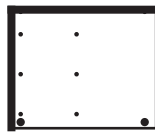

**6** Upright small  
(47.5 x 57.7cm)  
P2893



**7** Large horizontal  
(96.7 x 57.6cm)  
P1342

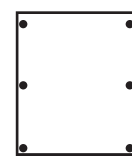

**8** Small horizontal  
(47.6 x 57.6cm)  
P1343



**9** Drawer base x 3  
(45.4 x 34.9cm)  
BO33955B



**10** Drawer wrap x 3  
(35 x 46.7 x 10cm)  
LA1869



**11** Drawer front x 3  
(48.8 x 15.7cm)  
P4308

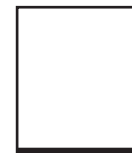

**12** Shelf  
(47.6 x 57.6cm)  
P1348



**13** Back  
(199.3 x 48.8cm)  
BO33902



**14** Foldy back  
(199.3 x 98cm)  
BO33933

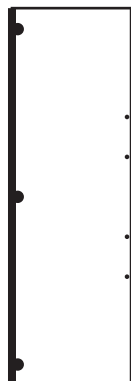

**15** Mirror door small  
(151.2 x 48.8cm)  
PS3324



**16** Plinth front  
(145.7 x 14cm)  
P7336C



**17** Plinth back  
(145.7 x 5.4cm)  
P7337C























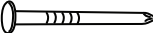

**18** Pelmet  
(149 x 4.5cm)  
FA248

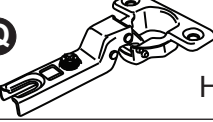

# Components - Fittings

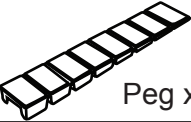
Please check you have all the fittings listed below

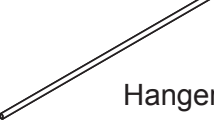
**Note:** The quantities below are the correct amount to complete the assembly. In some cases more fittings may be supplied than are required.

<b>A</b>  <small>FK1324</small> 40mm Screw x 9	<b>B</b>  <small>FK1980</small> 20mm Screw x 12	<b>C</b>  <small>FK1981</small> 9mm Screw x 6
<b>D</b>  <small>FK1400</small> 15mm Screw x 32	<b>E</b>  <small>FK1301</small> 10mm Fixing screw drawer x 12	<b>F</b>  <small>FK1309</small> 12.5 mm Screw x 4
<b>G</b>  <small>FK1235</small> L-Bracket x 1	<b>H</b>  <small>FK1011</small> 24mm locking screw x 32	<b>I</b>  <small>FK1012</small> Large locking nut x 26
<b>J</b>  <small>FK1010</small> Small locking nut x 6	<b>K</b>  <small>FA1515</small> Nail x 60	<b>L</b>  <small>FK1419</small> Nail holder x 1
<b>M</b>  <small>FK1217</small> Hanger rail support x 4	<b>N</b>  <small>FK1207</small> Board carrier x 4	<b>O</b>  <small>FK1311</small> 15mm Screw x 16
<b>P</b>  <small>FK1269</small> Hinge back x 9	<b>Q</b>  <small>FK1268</small> Hinge door x 9	<b>R</b>  <small>PM16951</small> Runner x 6
<b>S</b>  <small>FK1234</small> Peg x 2	<b>T</b>  <small>GR1975</small> Door/Drawer handle x 6	<b>U</b>  <small>PM1873</small> Hanger rail small x 1
<b>V</b>  <small>PM1884</small> Hanger rail large x 1	<b>W</b>  <small>FK1250</small> Drawerbase support x 6	<b>X</b>  <small>ZF99936</small> Wall plug and parkerscrew x 1

## Tools required

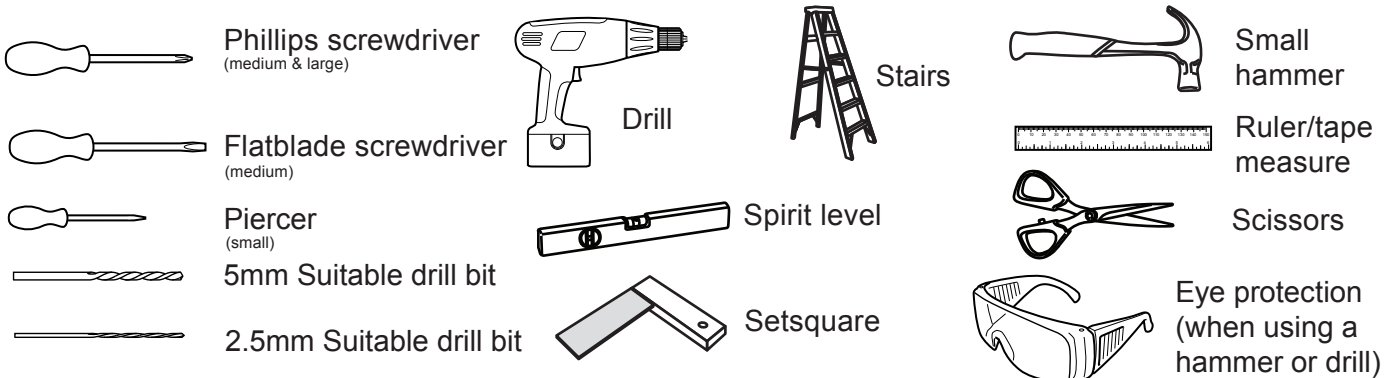

Ruler- Use this ruler to help correctly identify the screws

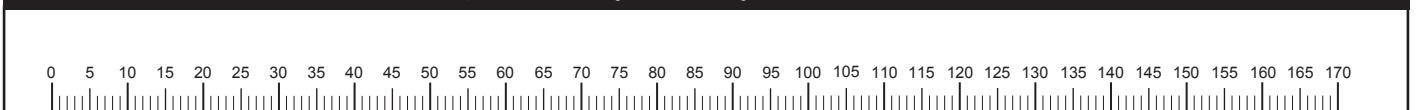

# Assembly Instructions

## Step 1

### Drawer assembly x 3

**a:** Insert two small locking nuts **J** into drawer wrap **10**.

Make sure the 'arrow' on **J** is pointing towards the hole in the edge of **10**.

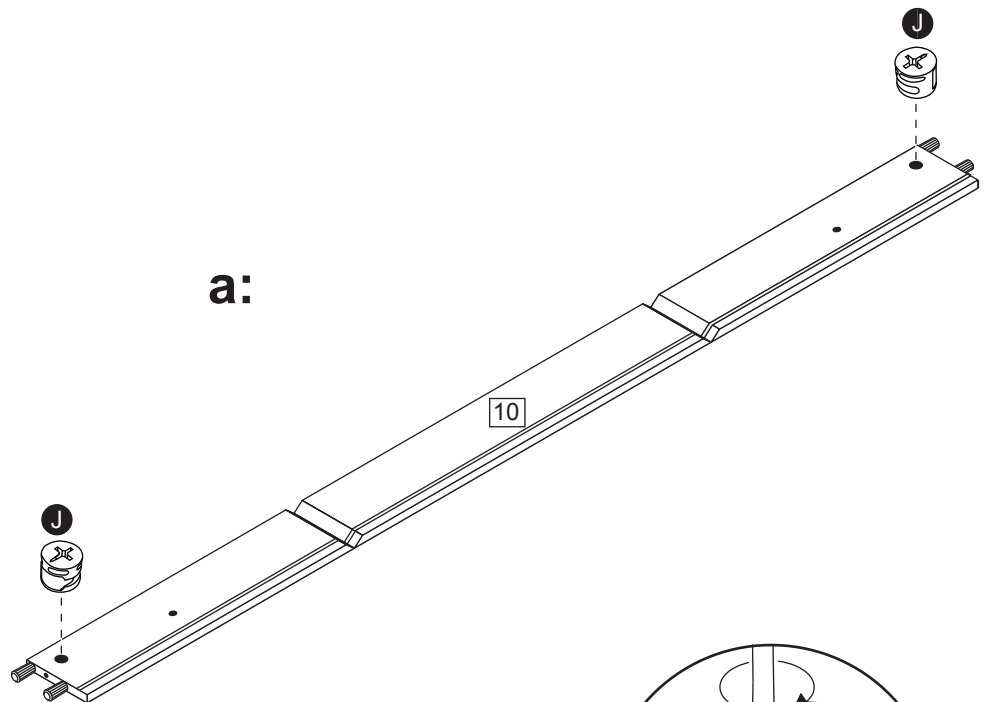

**b:** Screw 24mm locking screws **H** into holes shown on back of drawer front **11**.

Make sure 24mm locking screws **H** are tightened right up against drawer front **11**.

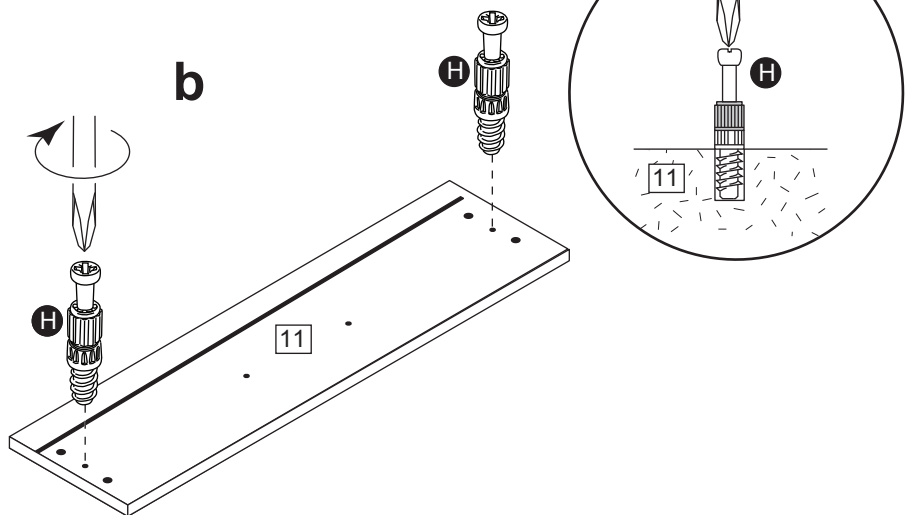

**c:** Slide drawer base **9** into grooves shown on drawer wrap **10**.

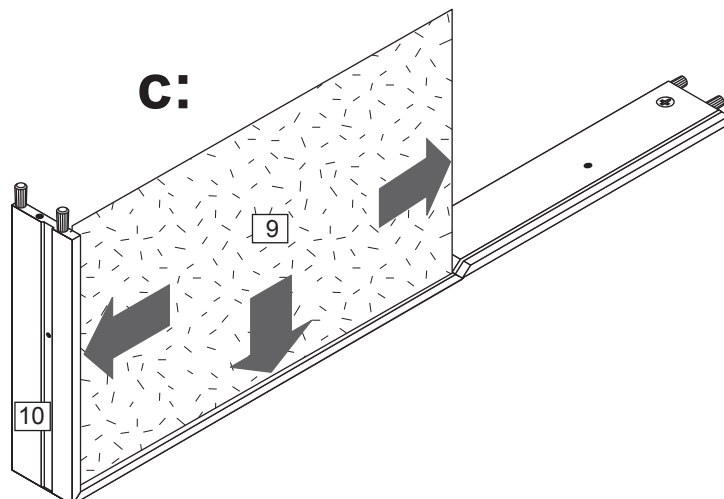

# Assembly Instructions

## Step 1 - continued

**d:** Turn the drawer wrap assembly over and push onto drawer front **11**. Use a philips or flatblade screwdriver, that is a good fit, to turn small locking nut **J** as far as it will go - more than 1/2 turn.

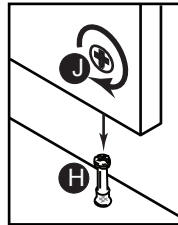

**d**

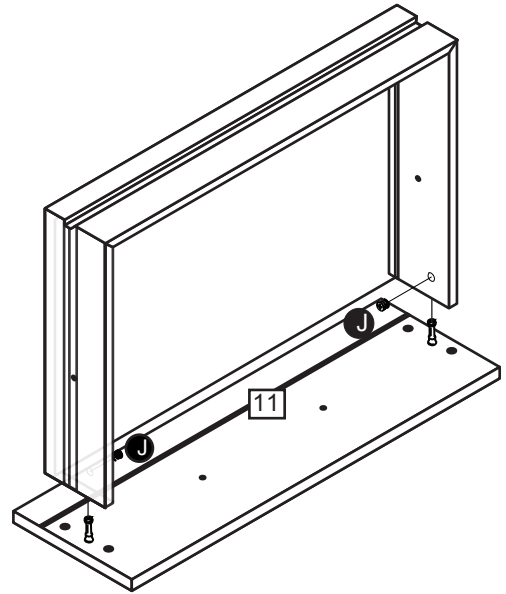

**e:** Fix drawer handle **T** onto drawer front **11** using 30mm screw **B**. Turn over drawer and slide Drawerbase supports **W** in corner as shown and fix them, using the attached screws.

**e:**

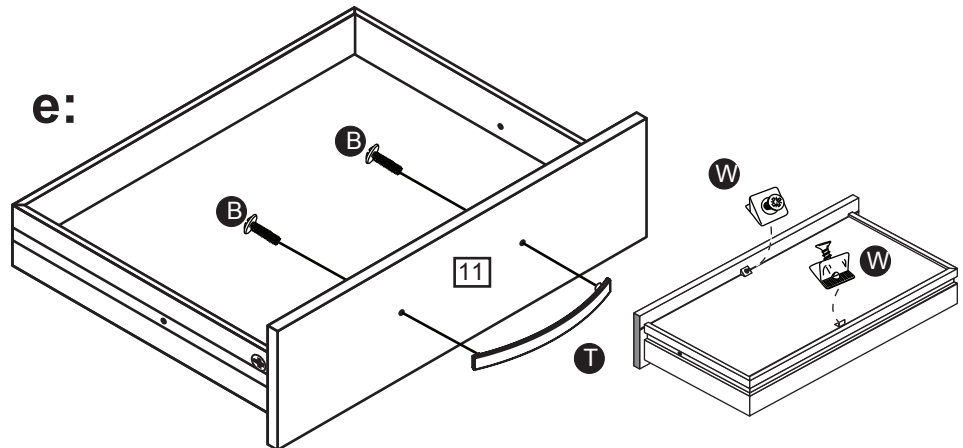

## Step 2

### Attaching runners

**a:** Slide top of runners **R** forward and fix on upright **3** as shown using 10mm fixing screw drawer **E**.

**a:**

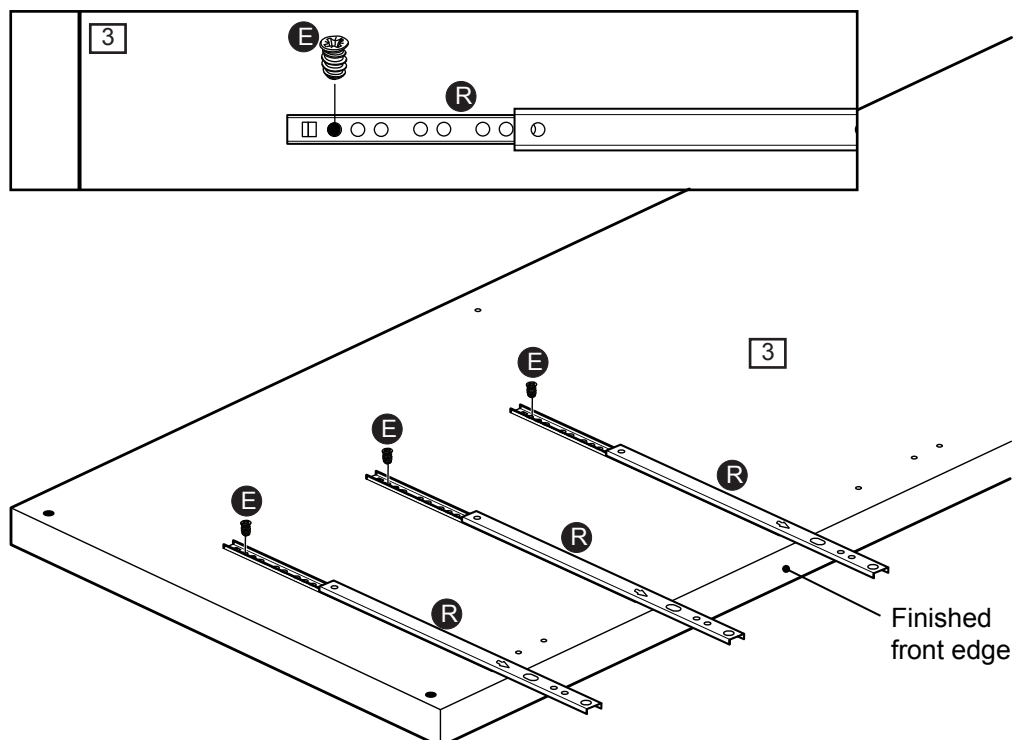

# Assembly Instructions

## Step 2 - continued

**b:** Slide top of runners **R** back.

Fix through 3rd hole of runner **R** and pre-drilled holes of upright **3** using 10mm fixing screw drawer **E**.

Fix through 1st and 9th hole of runners **R** using 15mm screw **O**.

**Note:** there are no pre-drilled holes for 15mm screw **O**.

Repeat **a** and **b** on upright small **6**.

**b**

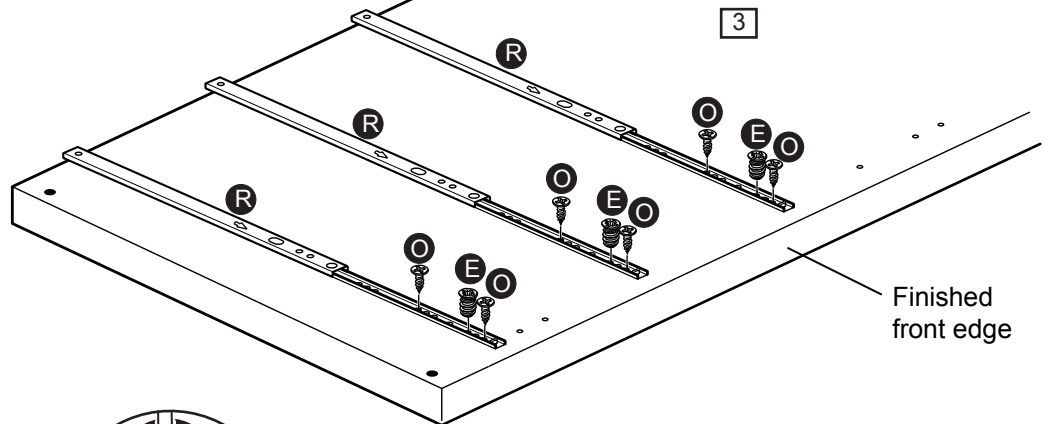
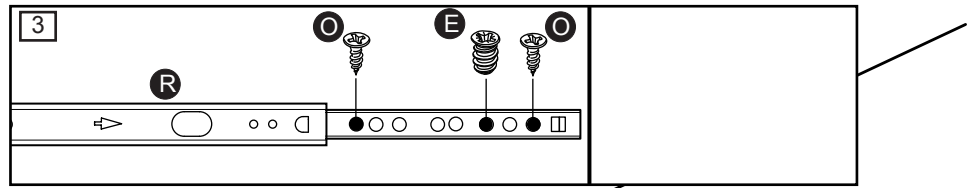

## Step 3

### Insert fittings

**a:** Screw 24mm locking screw **H** into upright **3**.

**Note:** Insert 24mm locking screw **H** as far as shown. **Do not over tighten.**

Attach hinge back **P** onto upright **3**.

Attach hanger rail support **M** using 12.5mm screw **F** onto upright **3**.

### Flip panel

**b:** Put board carrier **N** into upright **3**.

Attach hanger rail support **M** using 12.5mm screw **F** onto upright **3**.

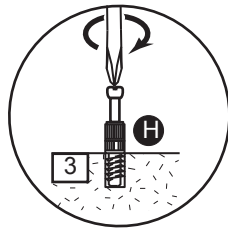

**a:**

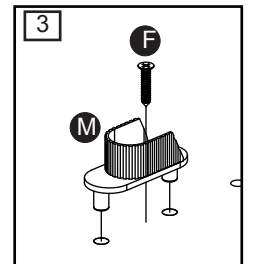
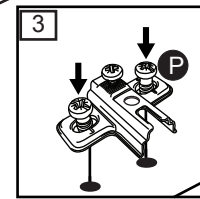
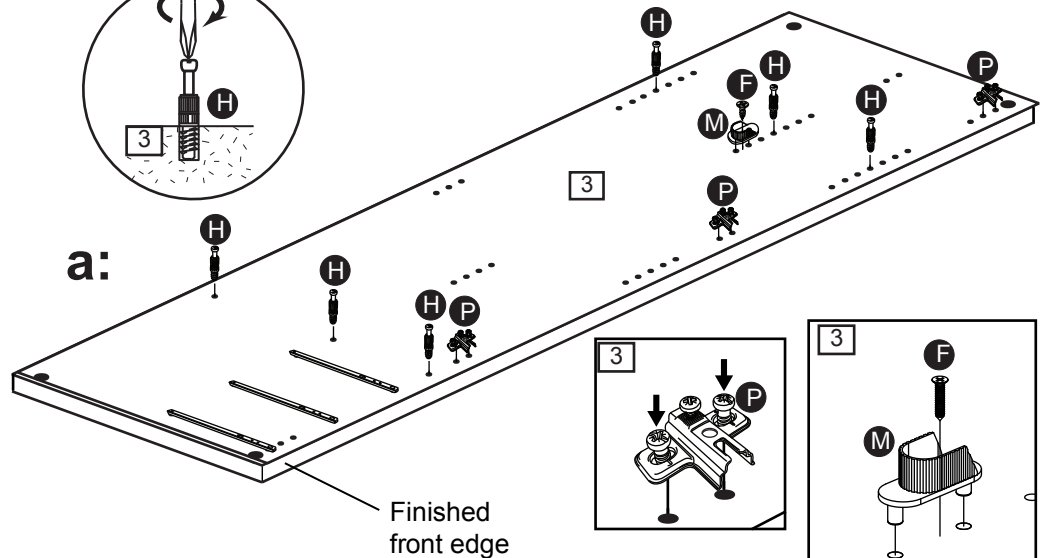

Finished front edge

**b**

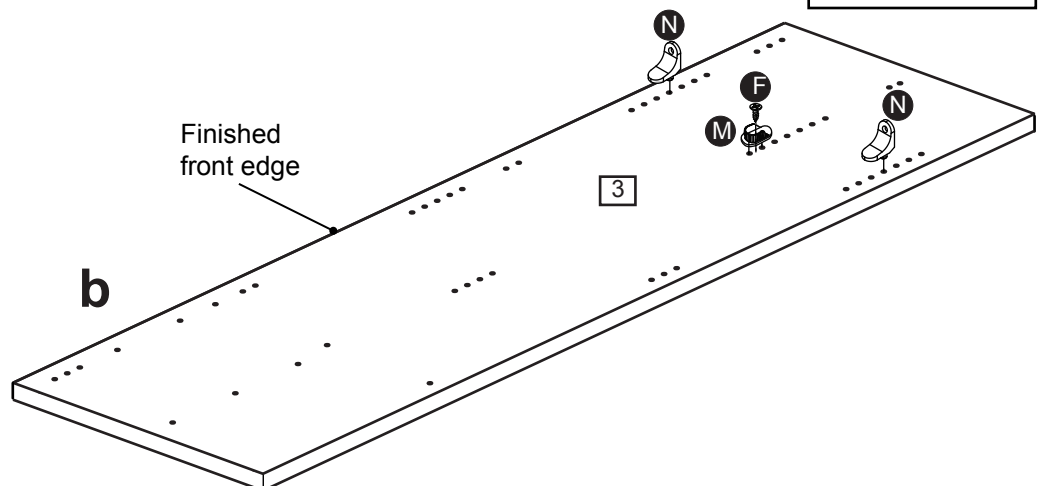

# Assembly Instructions

## Step 4

### Attaching plinths

Align the sides of plinth front [16] with bottom [5] as shown and attach using 40mm screw [A].

**Note:** there are no predrilled holes for 40mm screw [A].

**Note:** top and bottom panels [5] are identical. Only prepare one of the panels at this stage. This will be the bottom panel

Repeat with plinth back [17].

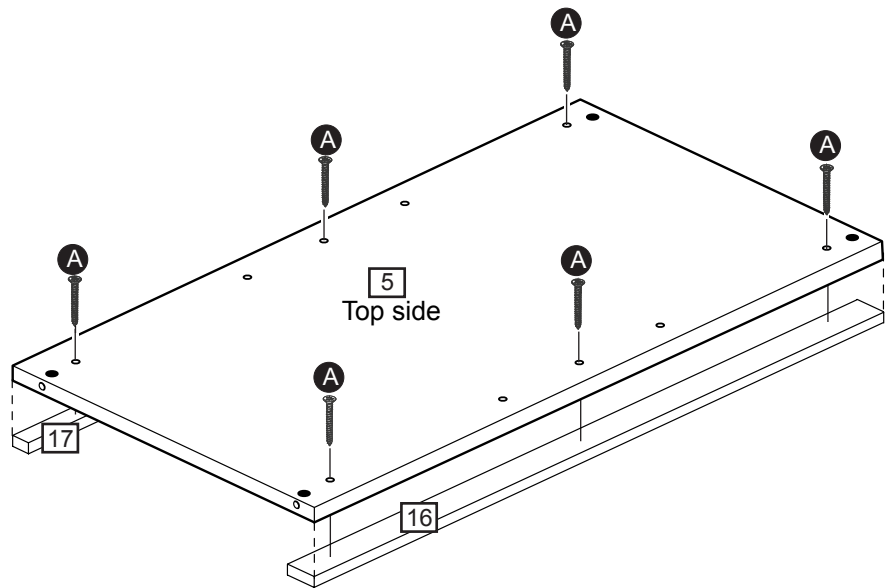

## Step 5

### Insert locking screws

Screw 24mm locking screw [H] into bottom [5].

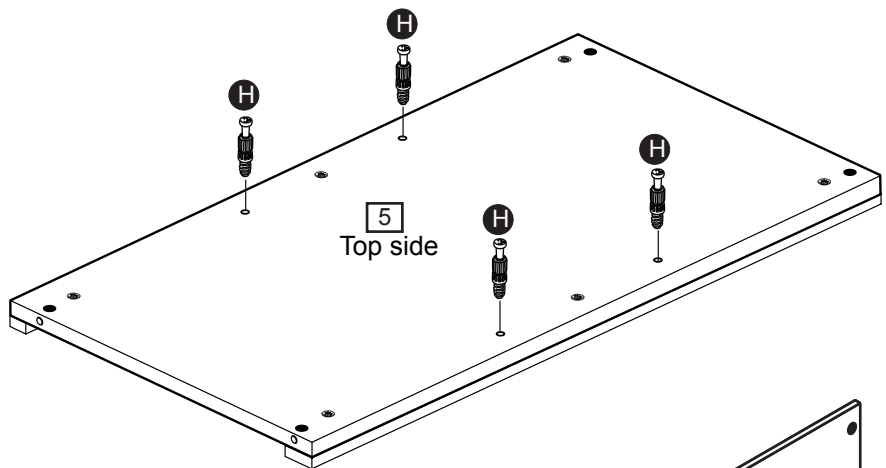

## Step 6

### Attaching panels

Position upright [3] onto bottom panel [5].

Insert two Large locking nuts [1] into upright as shown.

Use a screwdriver to turn locking nuts [1] clockwise to lock.

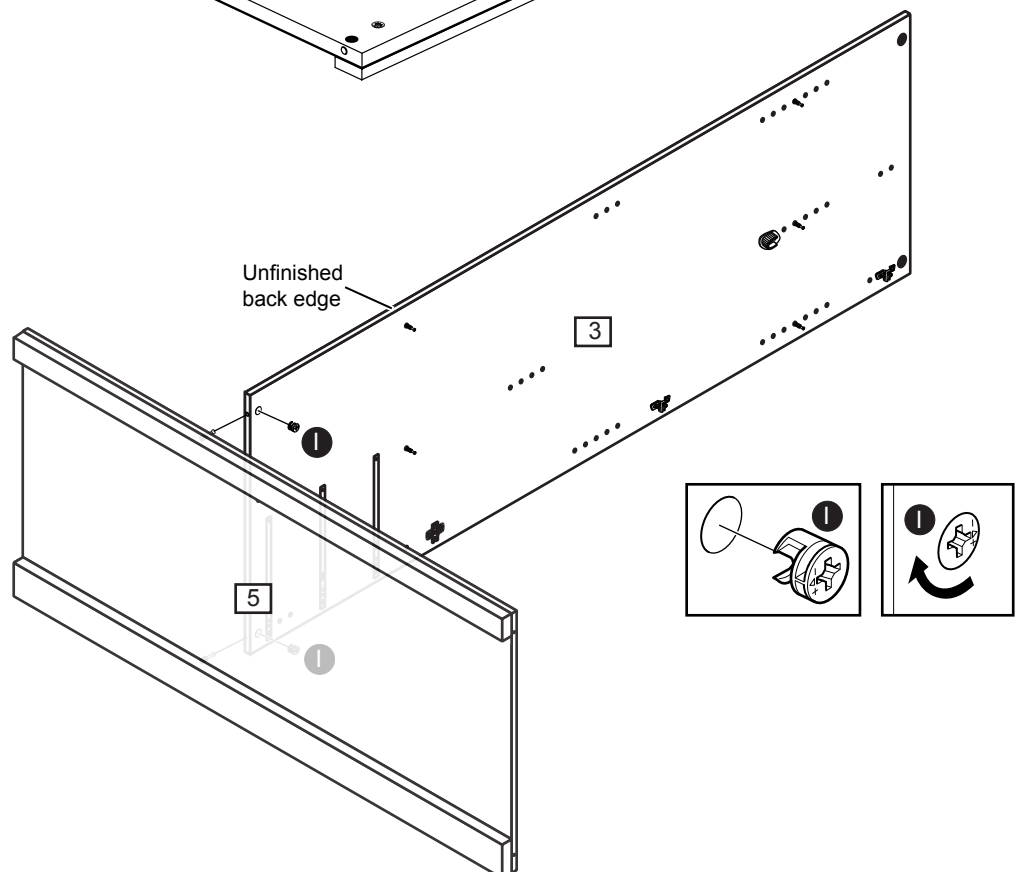



# Assembly Instructions

## Step 7

### Insert locking screws

Screw 24mm locking screw **H** into top **5**.

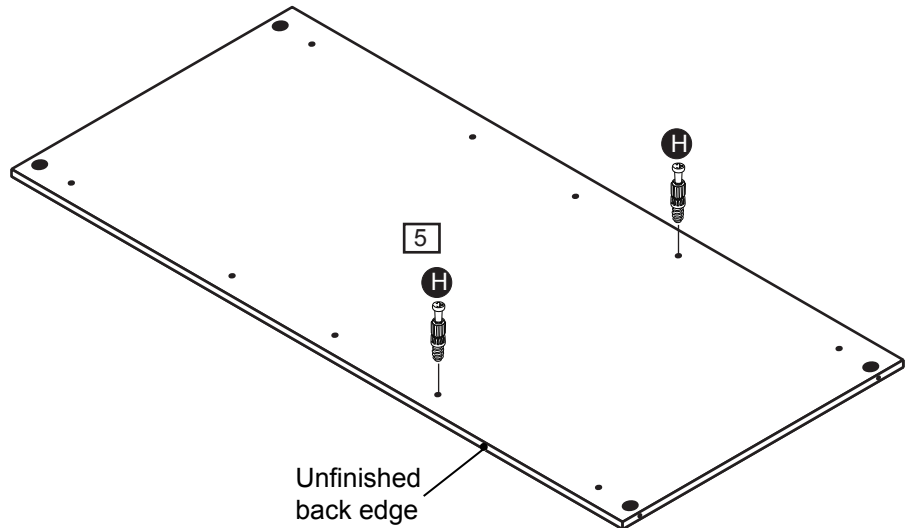

## Step 8

### Attaching panels

Two people are needed here.

Position top **5**, large horizontal **7** and small horizontal **8** onto upright **3**.

Insert two Large locking nuts **1** into upright **3**, 3 in large horizontal **7** and 2 in small **8** horizontal where shown.

Use a screwdriver to turn locking nuts **1** clockwise to lock.

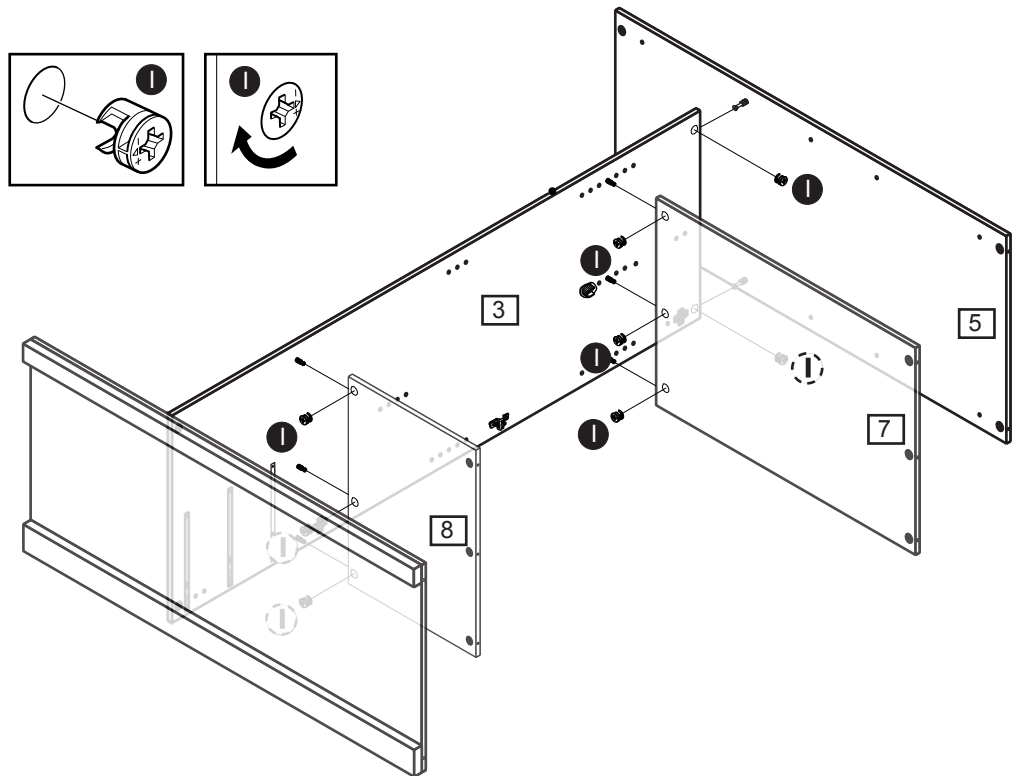

## Step 9

### Insert locking screws

Screw 24mm locking screw **H** into upright small **6**.

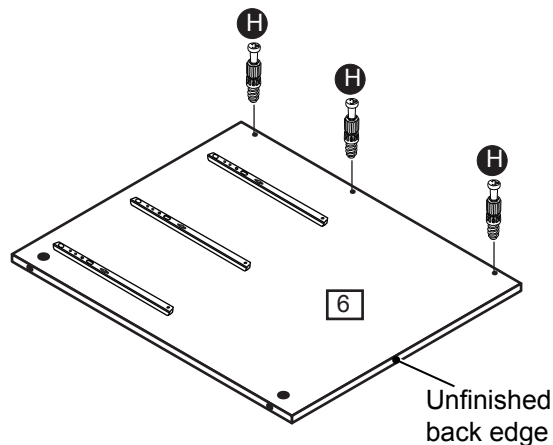

# Assembly Instructions

## Step 10

### Attaching panels

Two people are needed here.

Position upright small **6** onto bottom **5** and small horizontal **8**.

Insert two Large locking nuts **1** into upright small **6** and small horizontal **8** where shown.

Use a screwdriver to turn locking nuts **1** clockwise to lock.

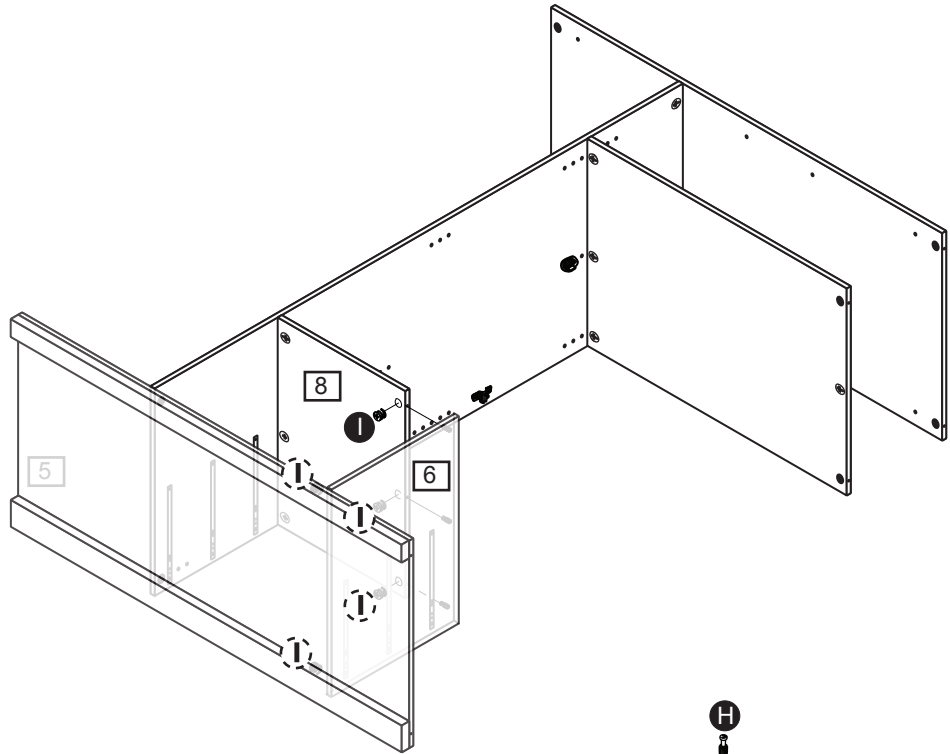
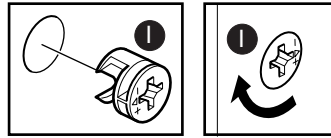

## Step 11

### Insert fittings

Put board carrier **N** into right side **2**.

Screw 24mm locking screws **H** into left side **1** and right side **2**.

**Note:** Insert 24mm locking screw **H** as far as shown. **Do not over tighten.**

Attach hinge back **P** onto left side **1** and right side **2**.

Attach hanger rail support **M** using 12.5mm screw **F** onto left side **1** and right side **2**.

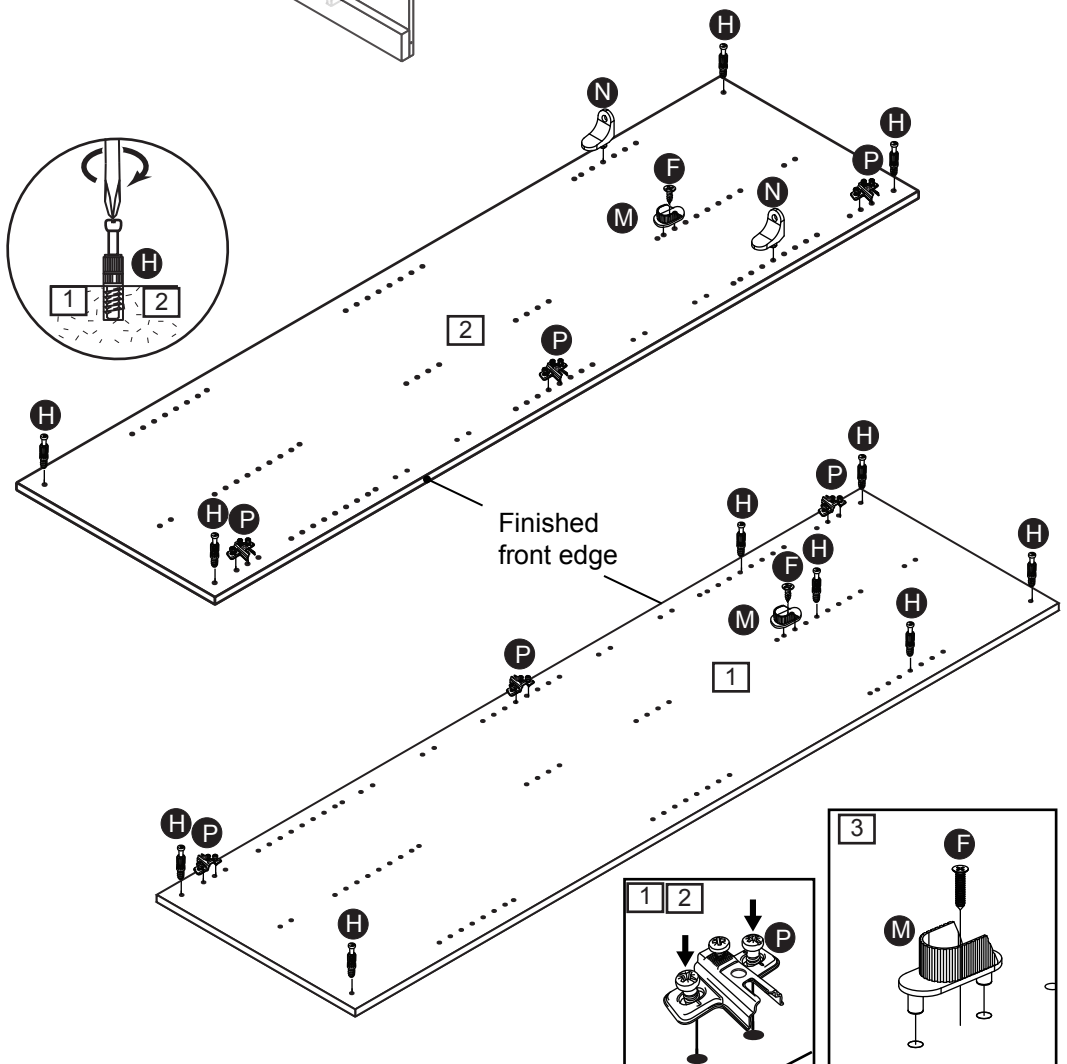
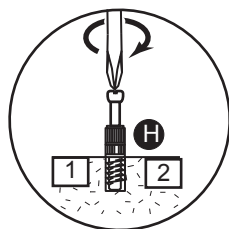

# Assembly Instructions

## Step 12

### Attaching panels

Two people are needed here.

Position right side **2** and left side **1** onto top and bottom **5**.

Insert six Large locking nuts in top and bottom **5**, insert 2 large locking nuts **1** into large horizontal **7**.

Use a screwdriver to turn locking nuts **1** clockwise to lock.

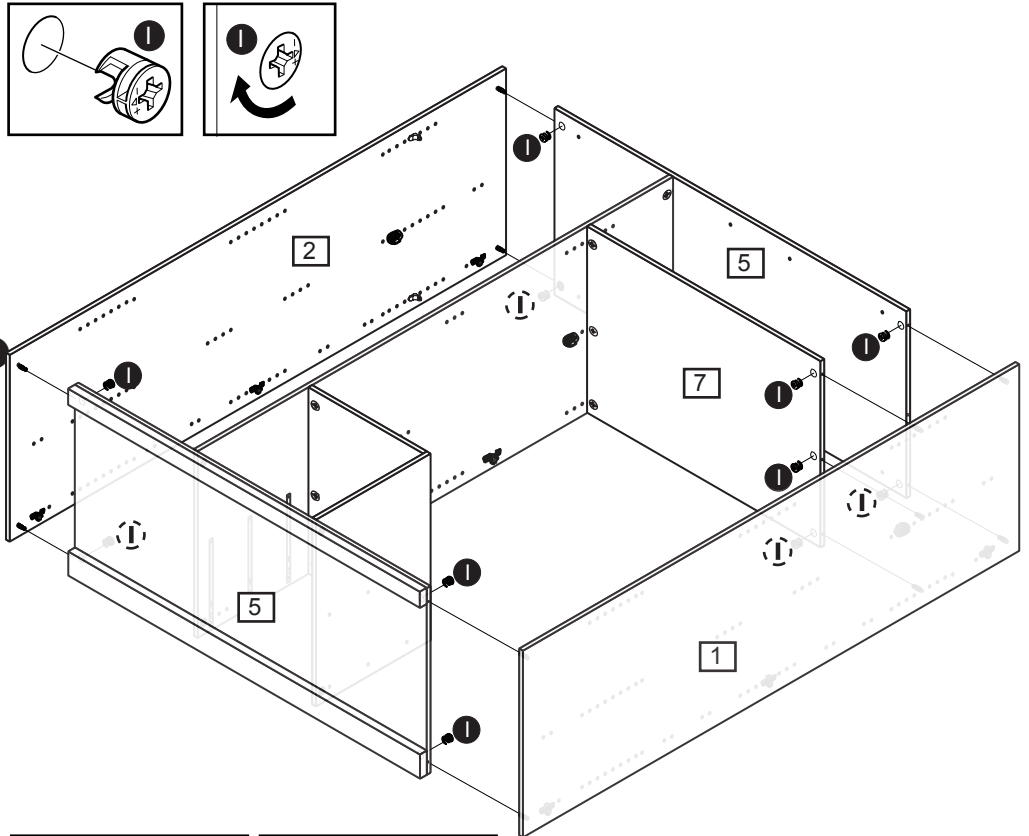

## Step 13

### Fitting back panels

Attach back **13** and foldy back **14** to back of wardrobe with the coloured surface facing the inside of the unit using nails **K** and 15mm screws **D**.

Use nail holder **L** to hold the nails **K** vertical and at correct distance as you secure the back **13** and foldy back **14**.

Nails **K** should be spaced about 150mm apart.

 Important: Cabinet **MUST** be 'square' when back is attached.

Stand unit up - 2 people required.

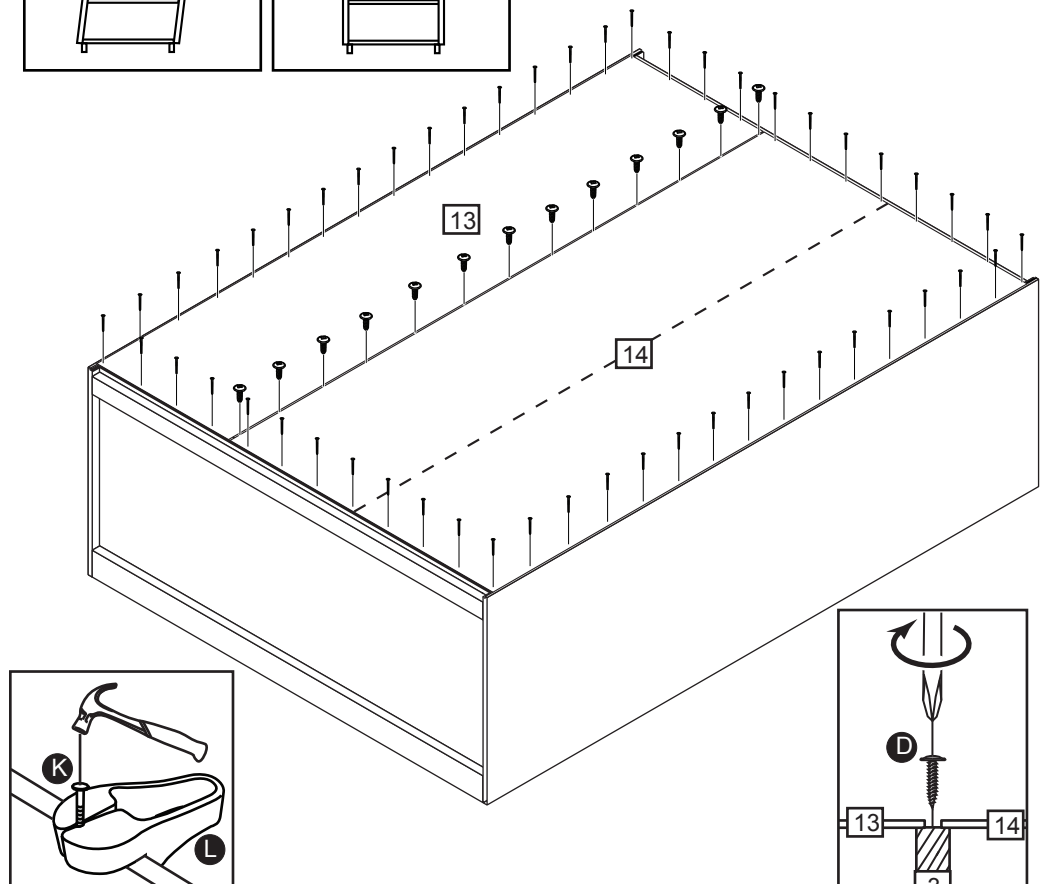
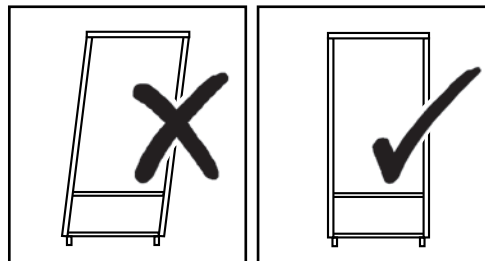

# Assembly Instructions

## Step 14

### Attaching pelment and L-bracket

Position pelment **18** onto top **5** as shown, fix by using three 40mm screws **A**.

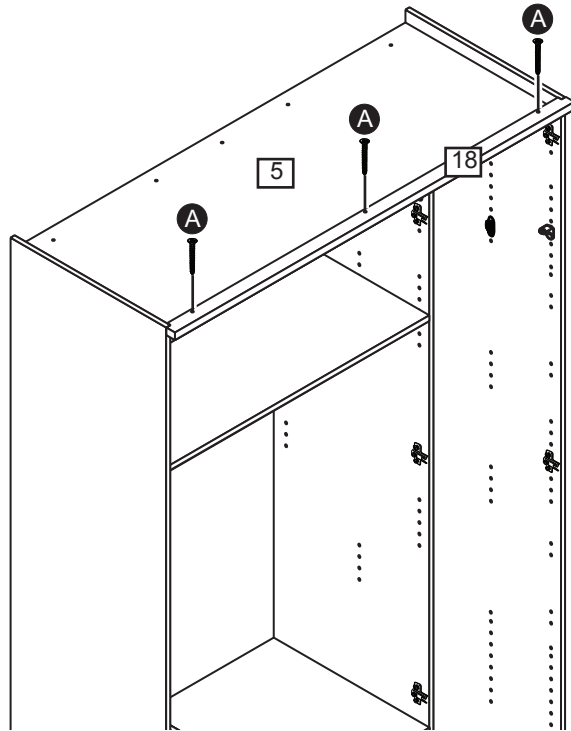

## Step 15

### Insert shelf

Position shelf **12** onto board carriers **N** and fix by screwing four 15mm screws **O** through board carrier **N** into shelf **12**.

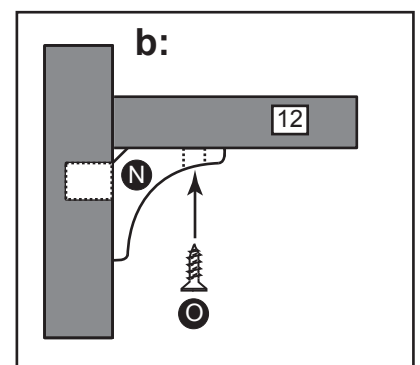
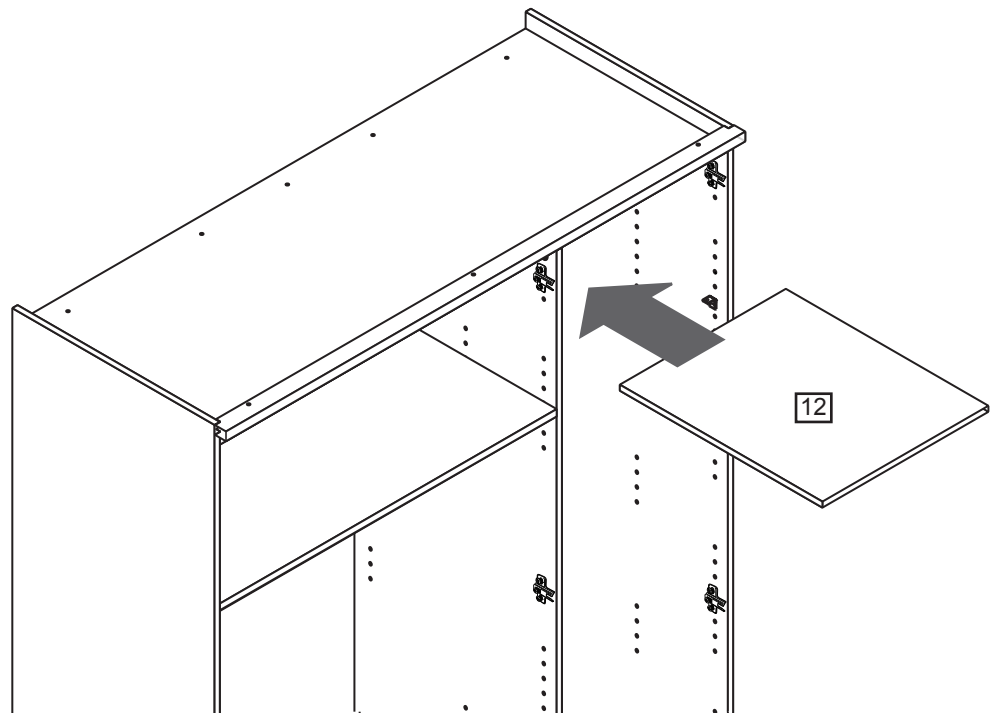

# Assembly Instructions

## Step 16

### Inserting drawers

**a:** Pull runners out. Slide drawers onto runners so they butt up against back of drawer front.

**b:** Fix through drawer sides into runners using 9mm screws **C**.

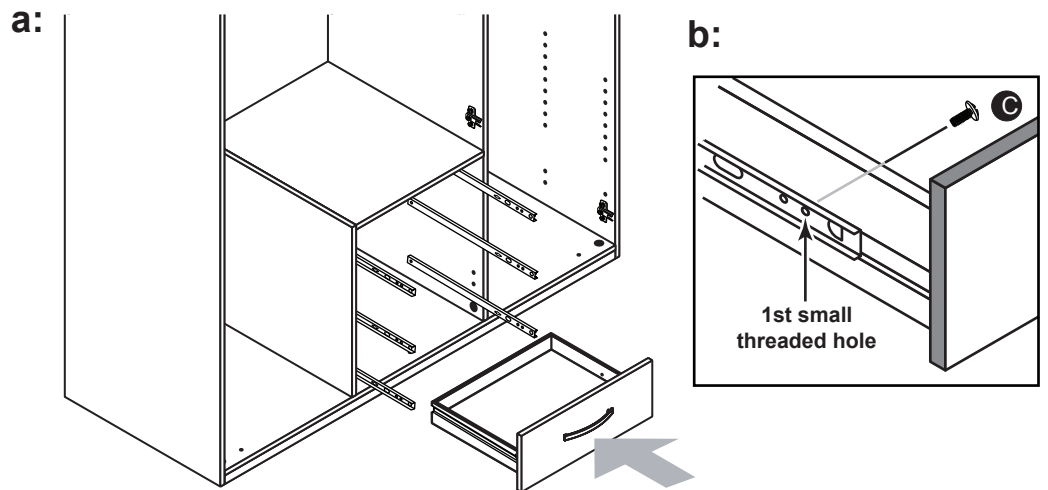

## Step 17

### Inserting hanger rails

Place hanger rails **U** and **V** onto hanger rail supports **M**.

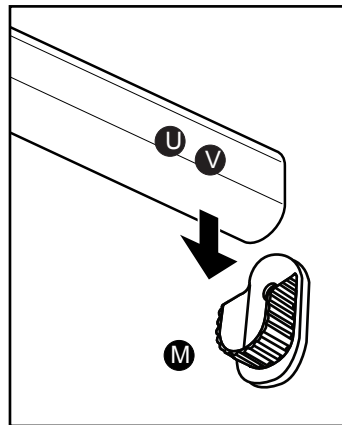

## Step 18

### Fitting hinges to doors

Fix three hinge door **Q** to each door **4** and mirror door small **15** using 15mm screws **D**.

Attach door handles **T** using 30mm screws **B**.

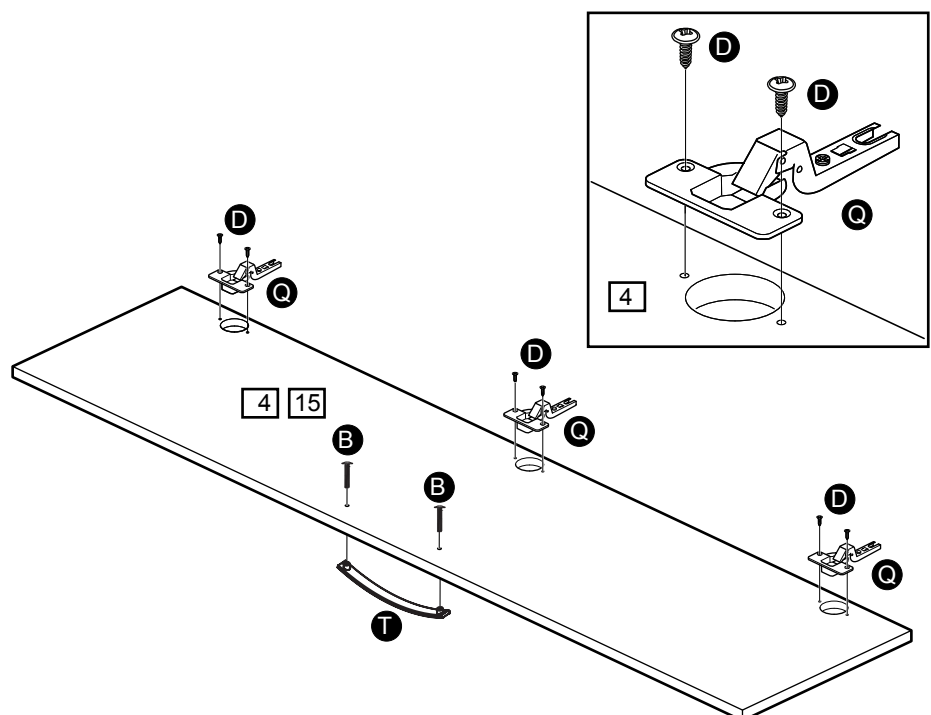

# Assembly Instructions

## Step 19

Hanging doors

**a:** With help, slot hinge door **Q** onto hinge back **P**.

**b:** Tighten screw shown to lock hinges in position.

Repeat **a** and **b** for other doors.

See 'Hinge adjustment' in step 20 if the doors need adjusting.

**c:** Position L-Bracket **G** onto top **5** as shown, fix by using 15mm screw **D**.

Note: there are no pre-drilled holes for 15mm screw **D**.

Use **X** to fix on the wall, please see last page for more information.

**d:** Before adjusting the doors, use a spirit level to check if the base of this unit is level front-to-back and side-to-side in the three positions shown.

Use pegs **S** to square your unit. Knock peg **S** in, as far as you require, under the ends of the unit and then snap off flush with the panel.

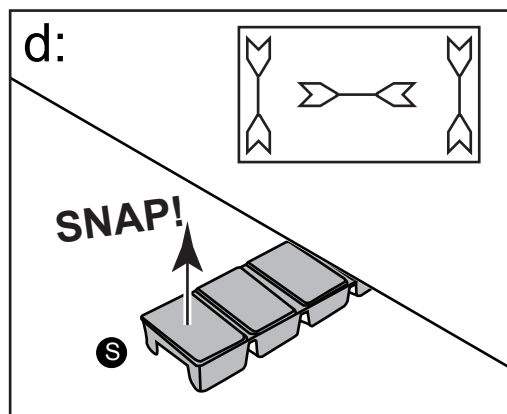
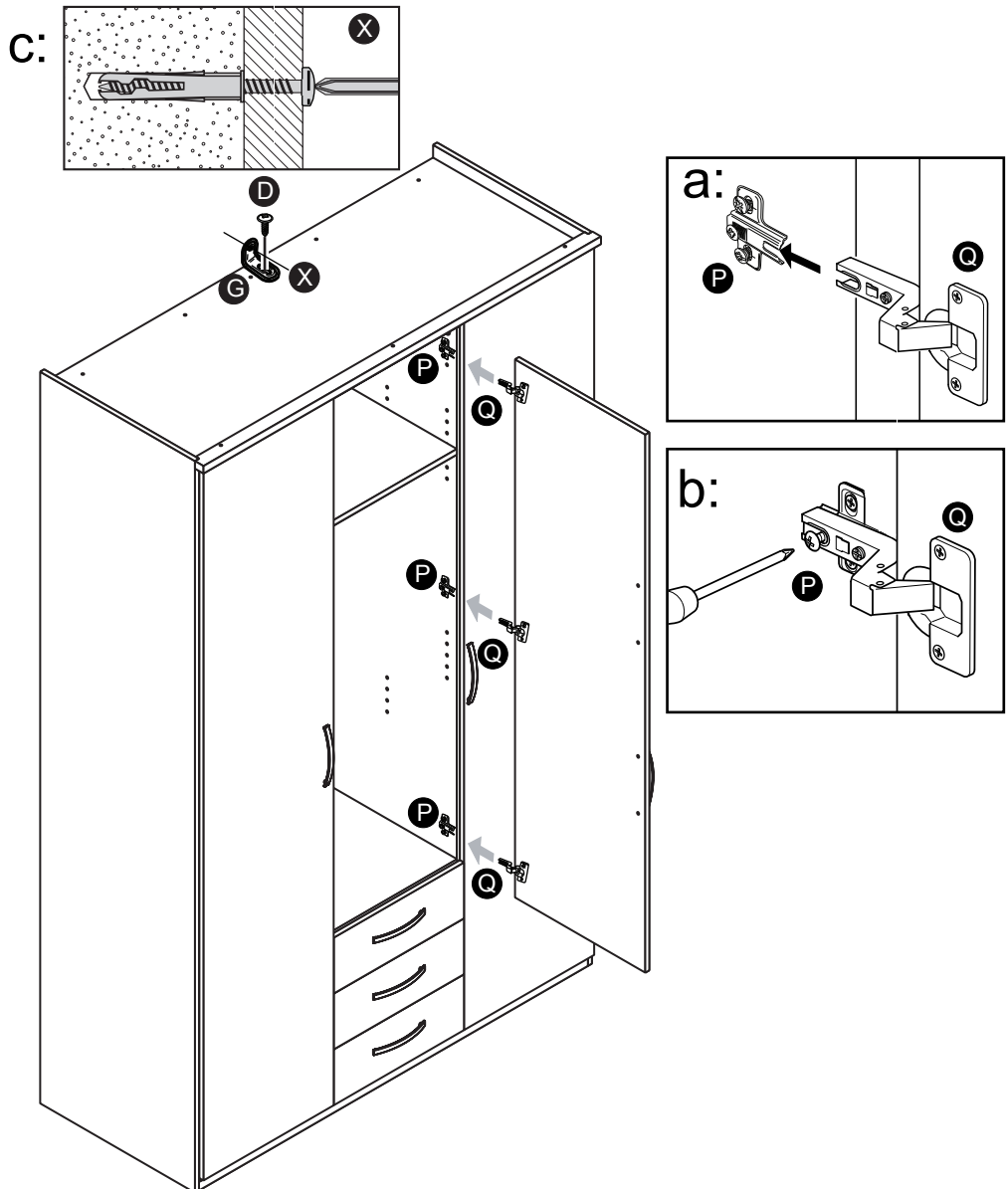

# Assembly Instructions

## Step 20

### Hinge adjustment

**a:** To move doors up or down: loosen screws shown and move doors to suit.

Once doors are aligned, re-tighten.

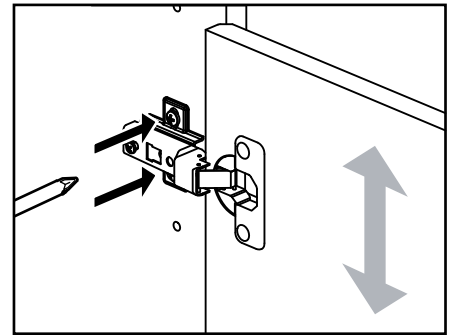
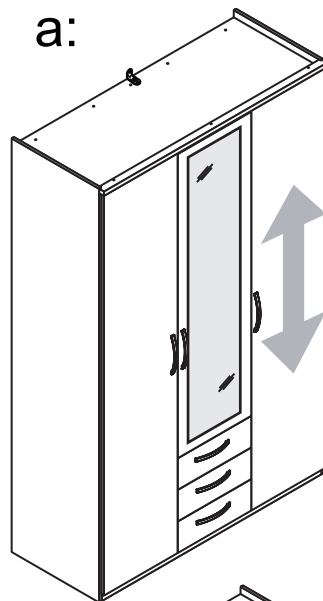

**b:** To move doors in or out: loosen screw shown and move doors to suit.

Re-tighten screws.

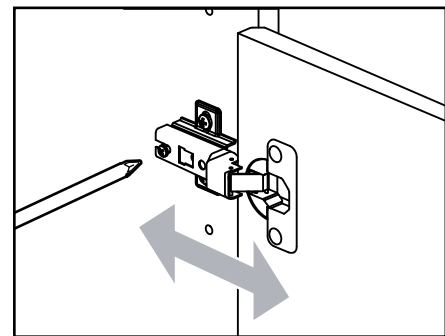
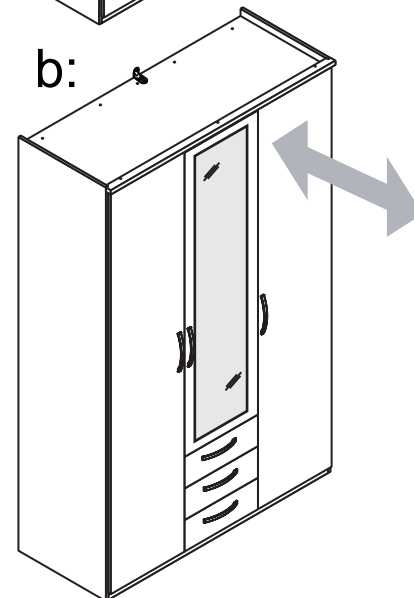

**c:** To move doors left or right: loosen screw shown and move doors to suit.

Re-tighten screws.

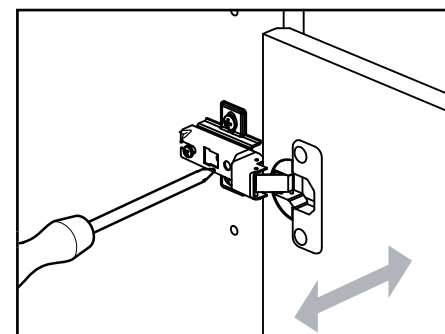
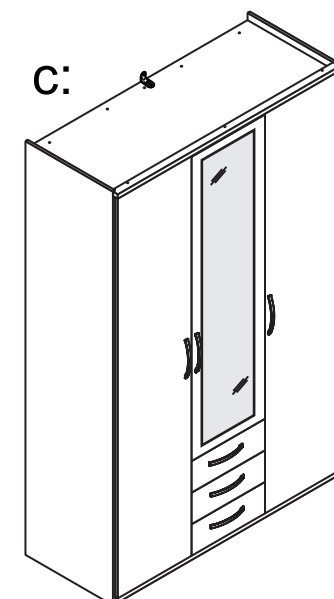

# A Guide to - Wall Mounting & Fixings

## Important note:

If plastic wall plugs are supplied with your product:



- these are only suitable for use in masonry walls.

If you are in any doubt about the correct wall plugs for your wall, seek professional advice.

Failure of the product due to using incorrect fixings is the responsibility of the installer.



**Important:** When drilling into walls always check that there are no hidden wires or pipes etc.

Make sure that the screws and wall plugs being used are suitable for supporting your unit. Consult a qualified tradesperson if you are unsure.

## Hints:

- 1: General rule:  Always use a larger screw and wall plug if you are not sure.
- 2: Ensure you use the recommended drill bit to match the wall plug and hole size.
- 3: Ensure you drill the hole horizontally, do not force the drill or enlarge the hole.
- 4: Take extra care when drilling high walls, ceilings and ceramic tiles. Ensure wall plugs are inserted beyond the thickness of the ceramic tiles to avoid the tiles splitting or cracking.
- 5: Ensure wall plugs are well fitted and are a tight fit in the drilled hole.

## Types of walls

You can use one of the following types of wall plug if your walls are made of brick, breeze block, concrete, stone or wood.

### No.1 "General Purpose" wall plug

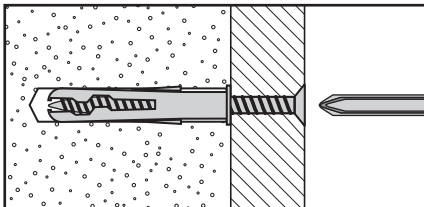

Generally aerated blocks should not be used to support heavy loads, use a specialist fitting in this case. For light loads, general purpose wall plugs can be used.

### No.2 "Plasterboard" wall plug

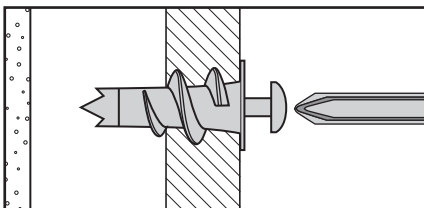

For use when attaching light loads on to plasterboard partitions.

### No.3 "Cavity Fixing" wall plug

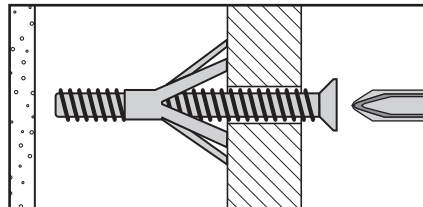

For use with plasterboard partitions or hollow wooden doors.

### No.4 "Cavity Fixing-Heavy Duty" wall plug

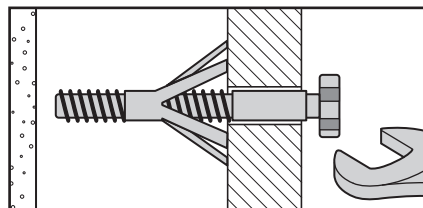

For use when fitting or supporting heavy loads such as shelving, wall cabinets and coat racks.

### No.5 "Hammer Fixing" wall plug

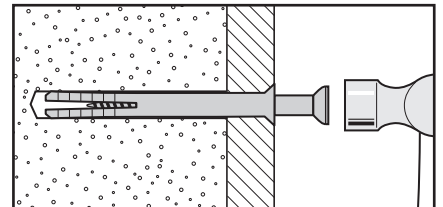

For use with walls stuck with plasterboard. The hammer fixing allows it to be fixed to the wall rather than the plasterboard. Always check the fixing is secure to the retaining wall.

### No.6 "Shield Anchor" wall plug Heavy loads

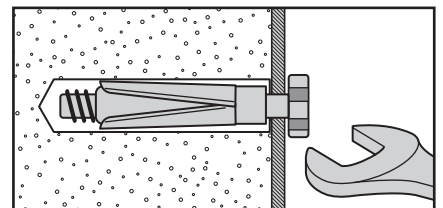

For use with heavier loads such as TV & HiFi speakers and satellite dishes etc.



## Care & Maintenance

**Safety:** Always check the fitting and location to ensure your safety in and around the home.

**Fitting:** From time to time check the fitting to ensure the wall plugs or screws do not become loose.