

Kids Sywell - 3 Door Robe

Assembly Instructions - Please keep for future reference

246/7634

228/8318

238/7460

238/9341

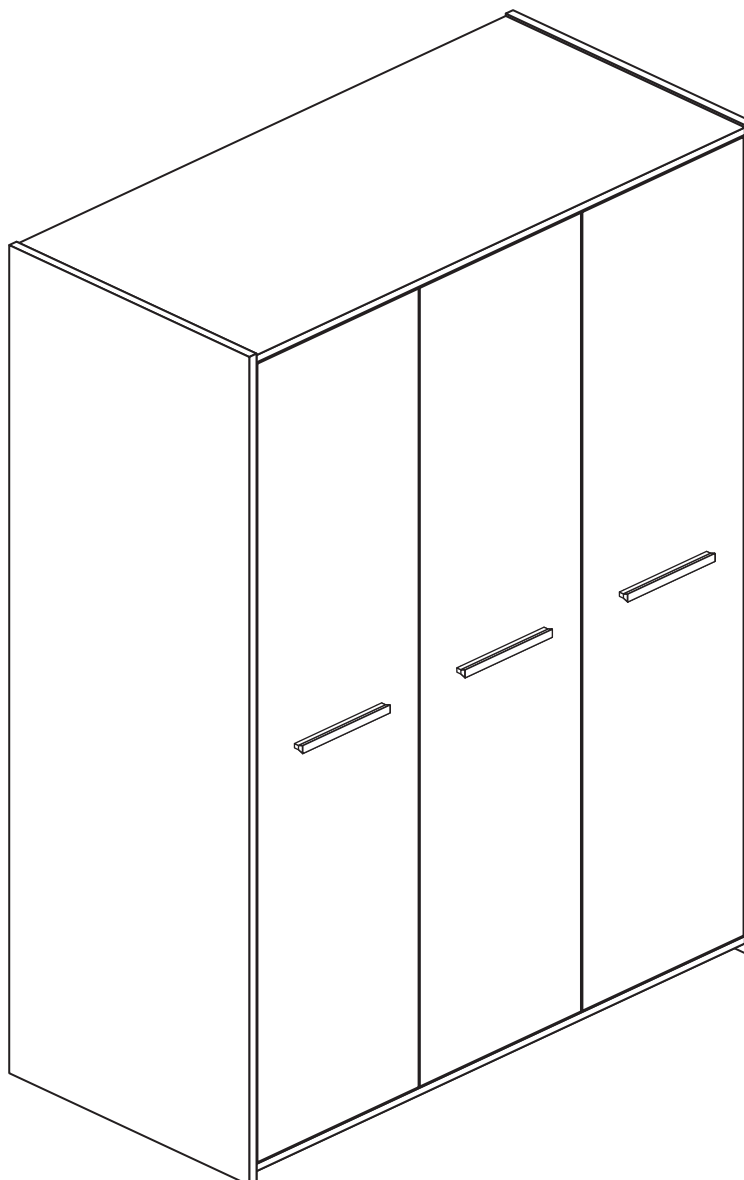

Dimensions

Width - 104cm

Depth - 50cm

Height - 172cm



**MADE IN
BRITAIN**

Important - Please read these instructions fully before starting assembly

If you need help or have damaged or missing parts, call the **Customer Helpline: 08456 400800**



Safety and Care Advice

Important - Please read these instructions fully before starting assembly

- **Warning:** This unit weighs approximately 59kgs. Please lift with care.
- Check you have all the components and tools listed on pages 2 and 3.
- Remove all fittings from the plastic bags and separate them into their groups.
- Keep children and animals away from the work area, small parts could choke if swallowed.
- Parts of the assembly will be easier with 2 people.

- Make sure you have enough space to layout the parts before starting.
- Do not stand or put weight on the product, this could cause damage.
- Assemble the item as close to its final position (in the same room) as possible.
- Assemble on a soft level surface to avoid damaging the unit or your floor (use opened out unit carton).



• We do not recommend the use of power drill/drivers **for inserting screws**, as this could damage the unit. Only use hand screwdrivers.







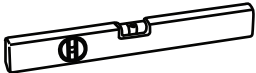

• **Safety note:** It is recommended that this unit is secured to a wall using the bracket supplied.

• Dispose of all packaging carefully and responsibly.

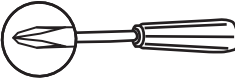
Care and maintenance

- Only clean using a damp cloth and mild detergent, do not use bleach or abrasive cleaners.
- From time to time check that there are no loose screws on this unit.
- This product should not be discarded with household waste. Take to your local authority waste disposal centre.

Tools required

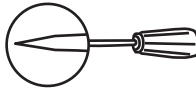
 Rule	 Spirit level	 Eye protection (when using a hammer or drill)	 Cross-head screwdriver	 Electric drill (only use when drilling into walls)	 Step ladder
 Square	 Scissors	 Hammer	 Bradawl		

Note: If required the next page can be cut out and used as reference throughout the assembly. Keep this page with these instructions for future reference.

Components - Panels

If you have damaged or missing components, call the **Customer Helpline: 08456 400800** quoting the reference numbers below

Please check you have all the panels listed below

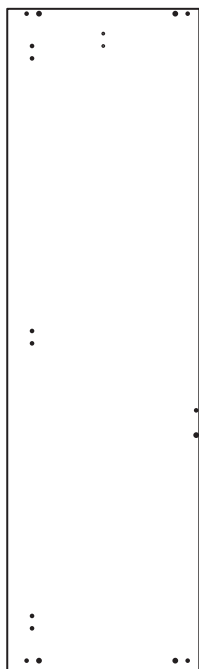

1 Left Side (D2560A)
(1711 x 496mm)

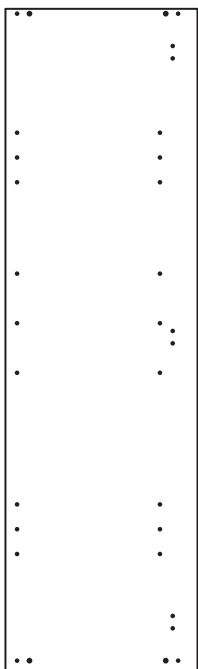

2 Right Side (D2569A)
(1711 x 496mm)

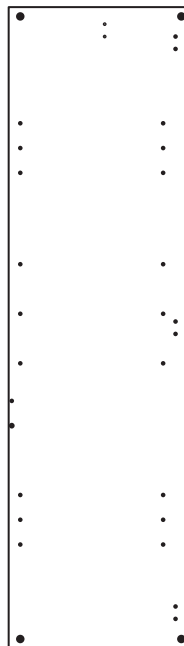

3 Upright (D2923A)
(1656 x 468mm)

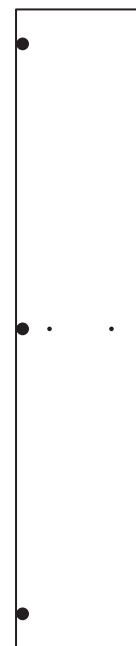

4 Door (D2563A)
(1650 x 333mm) x 3

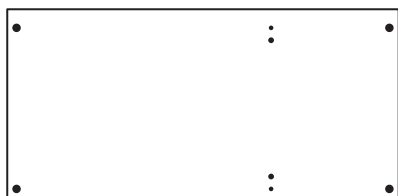

5 Top (D2568A)
(1011 x 494mm)

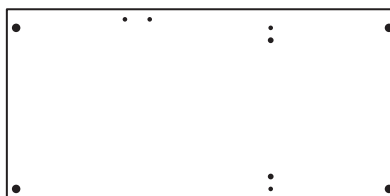

6 Base (D2922A)
(1011 x 494mm)

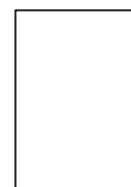

7 Shelf (D2574A)
(322 x 468mm) x 3

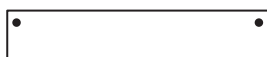

8 Rail (D2597A)
(674 x 125mm)



9 Hanging Rail (FHR666)
(666mm long)



10 Small Back (X1682-340)
(1682 x 340mm)

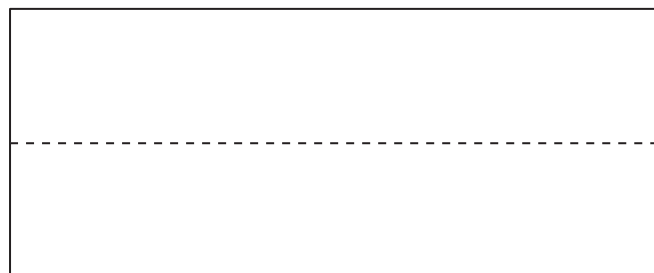

11 Large Back (X1682-694)
(1682 x 694mm)











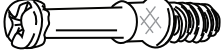

Components - Fittings

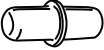
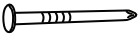
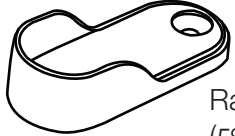
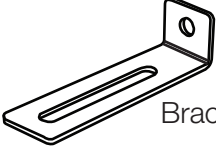
If you have damaged or missing components, call the **Customer Helpline: 08456 400800** quoting the reference numbers below

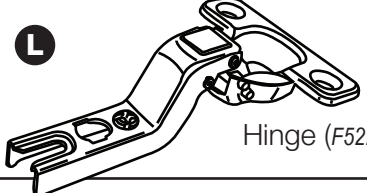
Please check you have all the fittings listed below

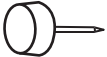
Note: The quantities below are the correct amount to complete the assembly. In some cases more fittings may be supplied than are required.

<p>A </p> <p>Wooden dowel (F22) x 14</p>	<p>B </p> <p>Metal dowel (F901) x 14</p>	<p>C </p> <p>Large locking nut (F900) x 14</p>
<p>D </p> <p>25mm Screw (F95) x 6</p>	<p>E </p> <p>13mm Screw (F79) x 1</p>	<p>F </p> <p>13mm Screw (F63) x 22</p>
<p>G </p> <p>Shelf stud (F110) x 14</p>	<p>H </p> <p>Nail (F51) x 36</p>	<p>I </p> <p>Rail Holder (F891) x 2</p>
<p>J </p> <p>Bracket (F327) x 1</p>	<p>K </p> <p>Hinge plate (F523) x 9</p>	<p>L </p> <p>Hinge (F522) x 9</p>
<p>M </p> <p>Nail screw (F277) x 5</p>	<p>N </p> <p>Back holder (F276) x 5 *These can also be round</p>	<p>O </p> <p>Plastic Nail (F91) x 4</p>
<p>P </p> <p>Handle (F315) x 3</p>		

Ruler - Use this ruler to help correctly identify the screws



Assembly Instructions

If you have damaged or missing components, call the Customer Helpline: 08456 400800 quoting the reference numbers below

Step 1

Prepare the upright

a: Insert 4 large locking nuts **C** into the upright **3**.

Note: The arrow on the locking nut **must** point towards the hole in the edge of the panel.

Tap 4 wooden dowels **A** into the upright **3**.

Note: Wooden dowels **must not** stick out from the edge by more than 10mm or they may damage other panels.

Screw a metal dowel **B** into the upright **3**.

Note: Tighten the metal dowel up fully against the panel.

b: Fit 3 hinge plates **K** onto the upright **3**, making sure that the slot is facing towards the finished front edge.

Fit the rail holder **I** to the upright **3** using 2 screws **F**.

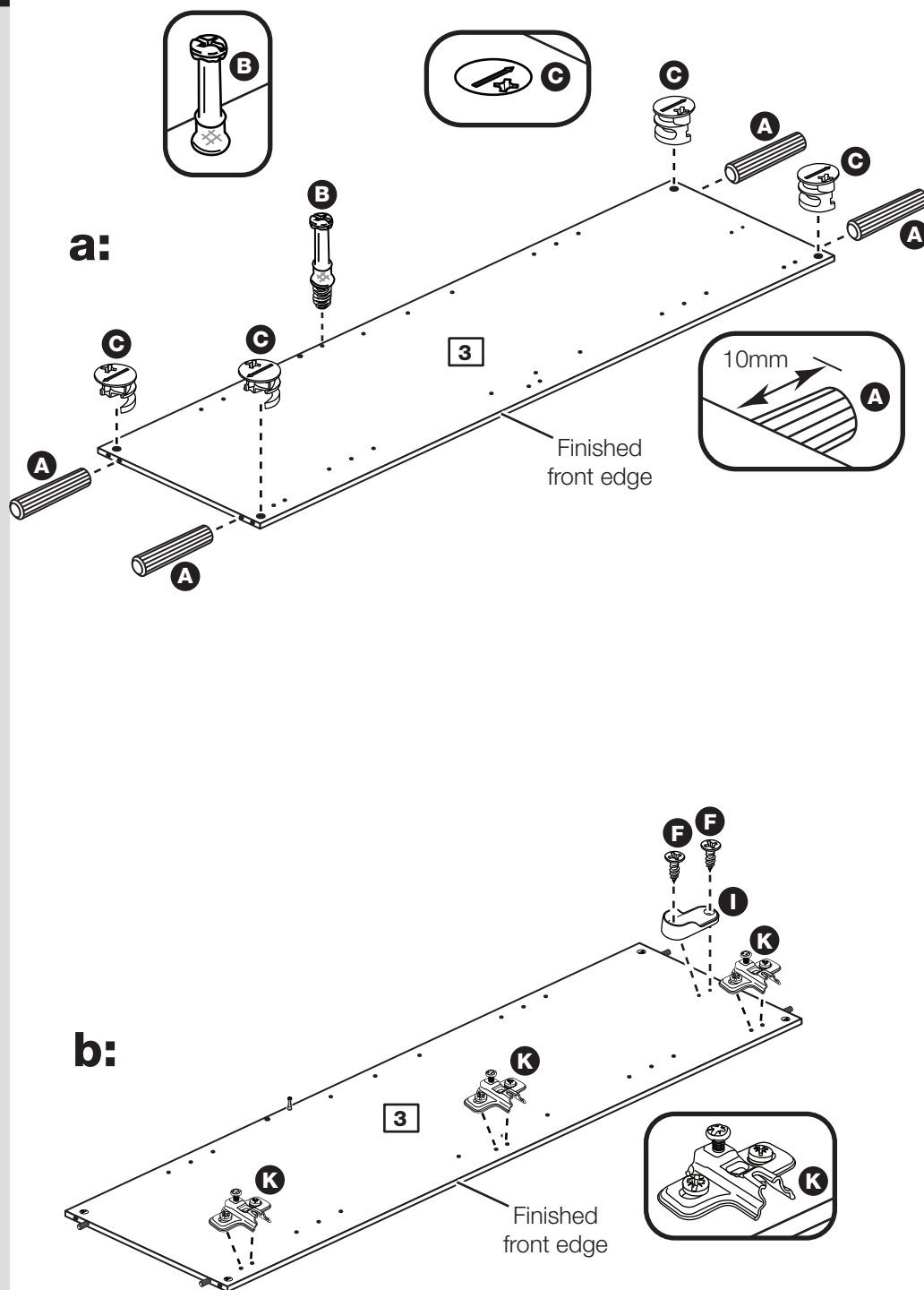

Assembly Instructions

Step 2

Prepare the top

Tap 4 wooden dowels **A** into the top **5**.

Insert 4 large locking nuts **C** into the top **5**.

Screw 2 metal dowels **B** into the top **5**.

Note: Tighten the metal dowels up fully against the panels.

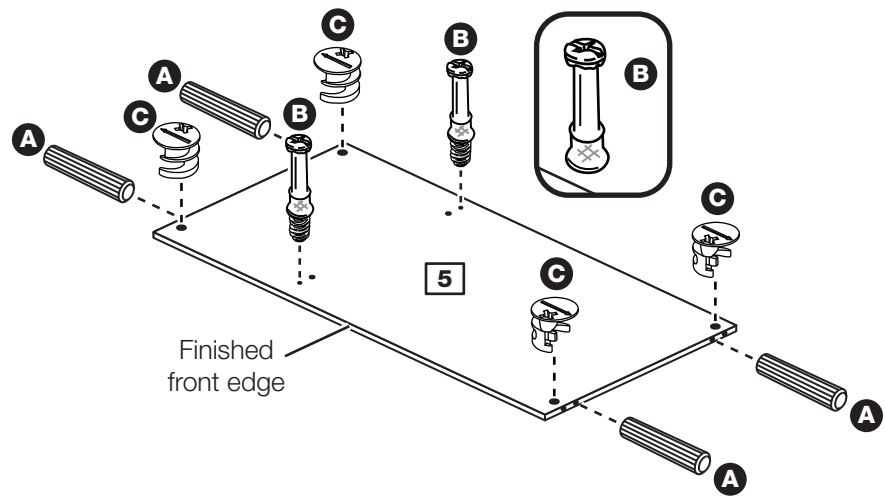

Step 3

Prepare the base

a: Tap 4 wooden dowels **A** into the base **6**.

Insert 4 large locking nuts **C** into the base **6**.

Turn the base over

b: Screw 2 metal dowels **B** into the base **6**.

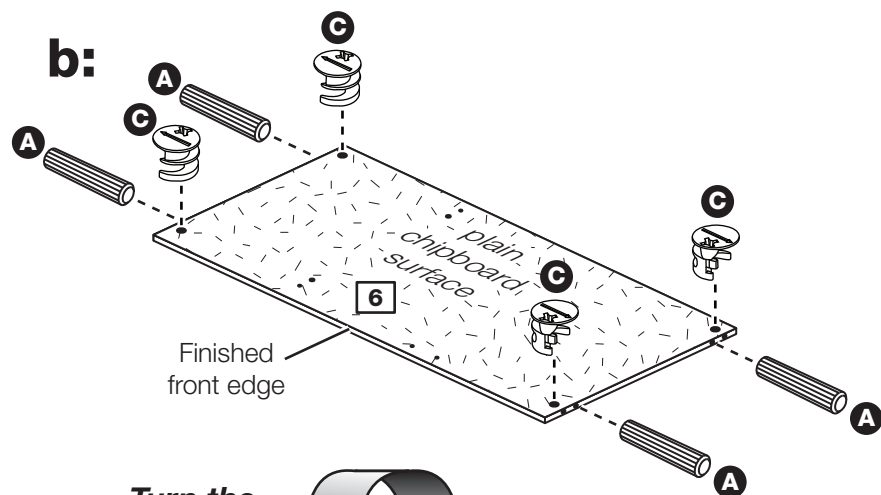

Turn the
base over

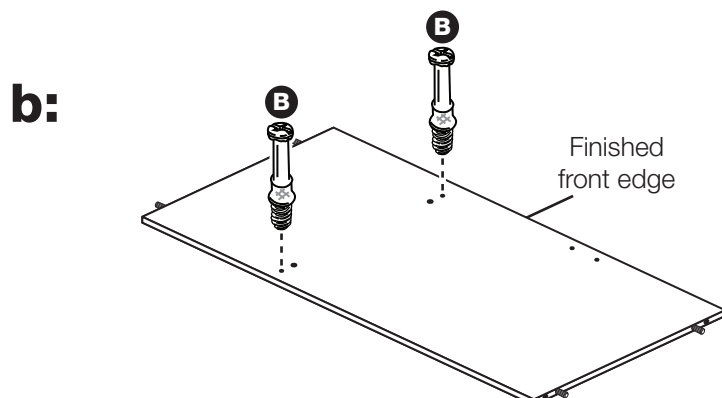

Assembly Instructions

Step 4

Fit the top and base to the upright

Push the top **5** and the base **6** onto the upright **3**.

Use a screwdriver to tighten the 4 large locking nuts **C** fitted to the upright **3**.

Note: Turn the large locking nuts **C** as far as they will go - more than 1/2 a turn.

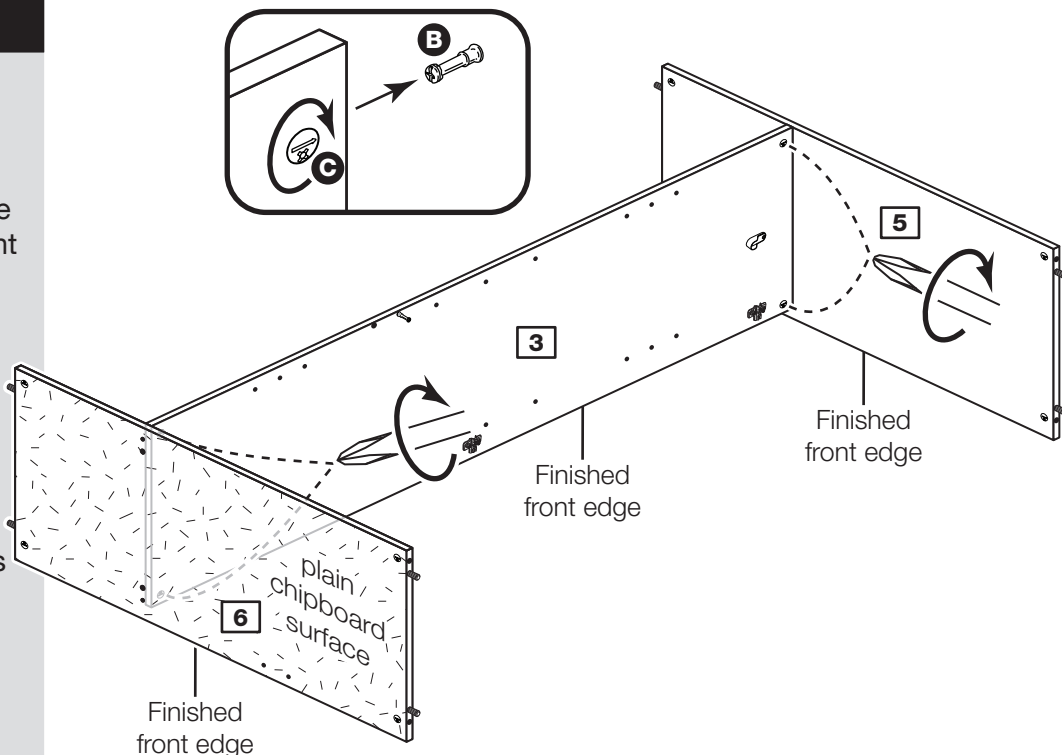

Step 5

Prepare the left side

Screw 5 metal dowels **B** into the left side **1**.

Note: Tighten the metal dowels up fully against the panels.

Fit 3 hinge plates **K** onto the left side **1**, making sure that the slot is facing towards the finished front edge.

Fit the rail holder **I** to the left side **1** using 2 screws **F**.

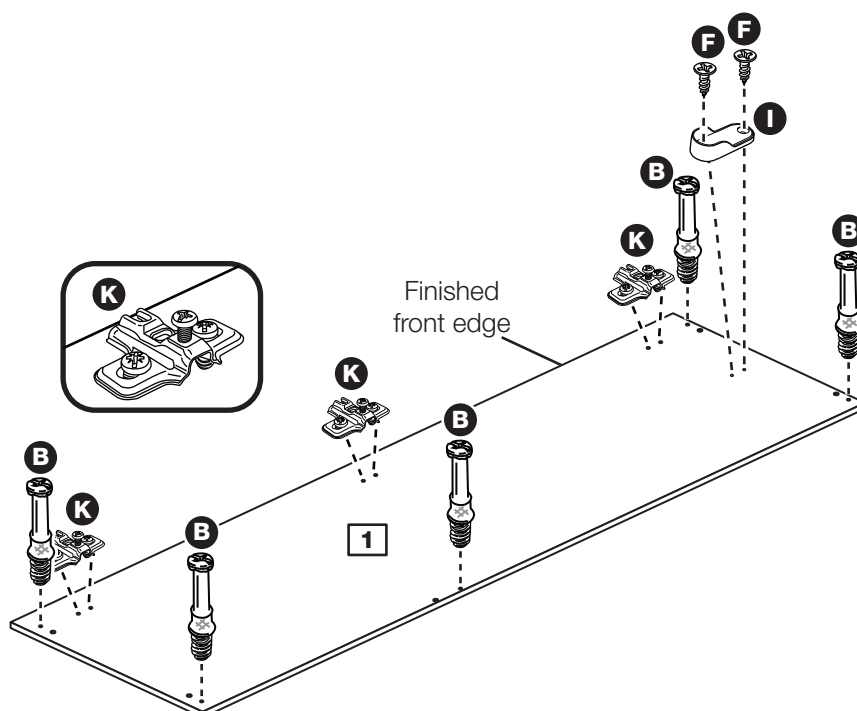

Assembly Instructions

Step 6

Prepare the right side

Screw 4 metal dowels **B** into the right side **2**.

Fit 3 hinge plates **K** onto the right side **2**, making sure that the slot is facing towards the finished front edge.

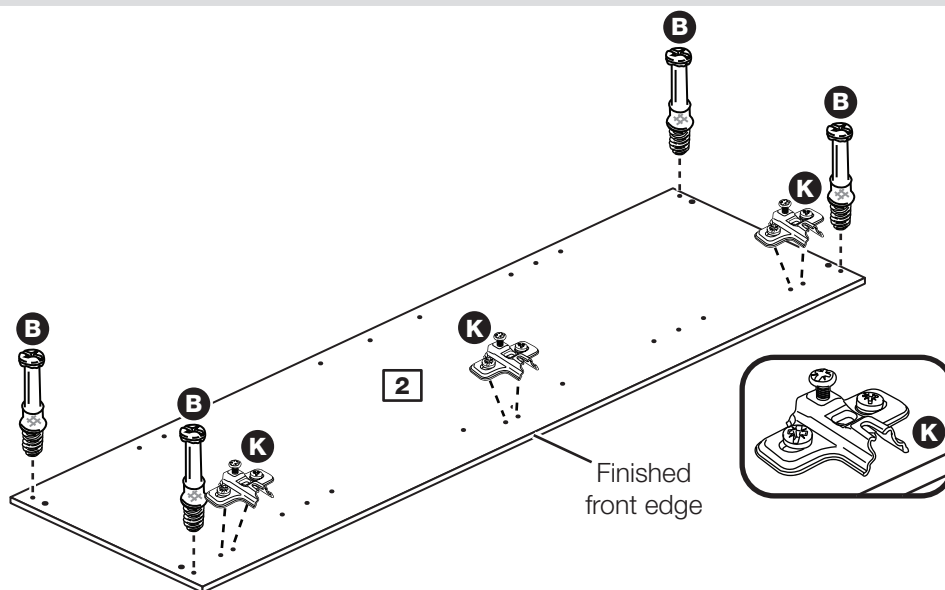

Step 7

Fit the right side

Push the right side **2** onto the top **5** and base **6**.

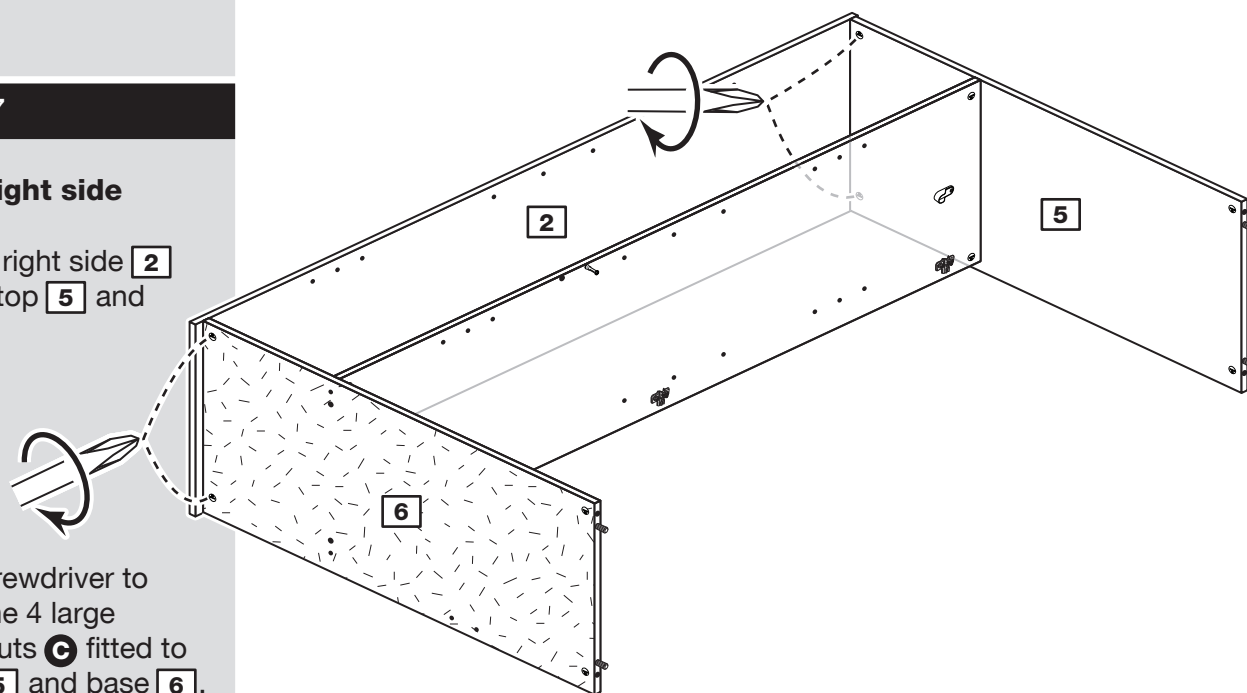

Use a screwdriver to tighten the 4 large locking nuts **C** fitted to the top **5** and base **6**.

Step 8

Prepare the rail

Tap 2 wooden dowels **A** into the rail **8**.

Insert 2 large locking nuts **C** into the rail **8**.

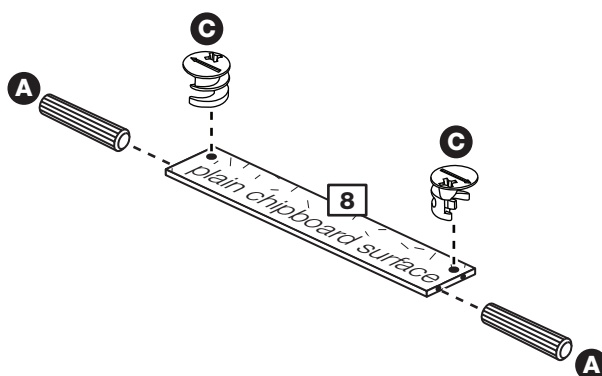

Assembly Instructions

Step 9

Fit the rail

Push the rail **8** onto the upright **3**.

Use a screwdriver to tighten the large locking nut **C** fitted to the rail **8**.

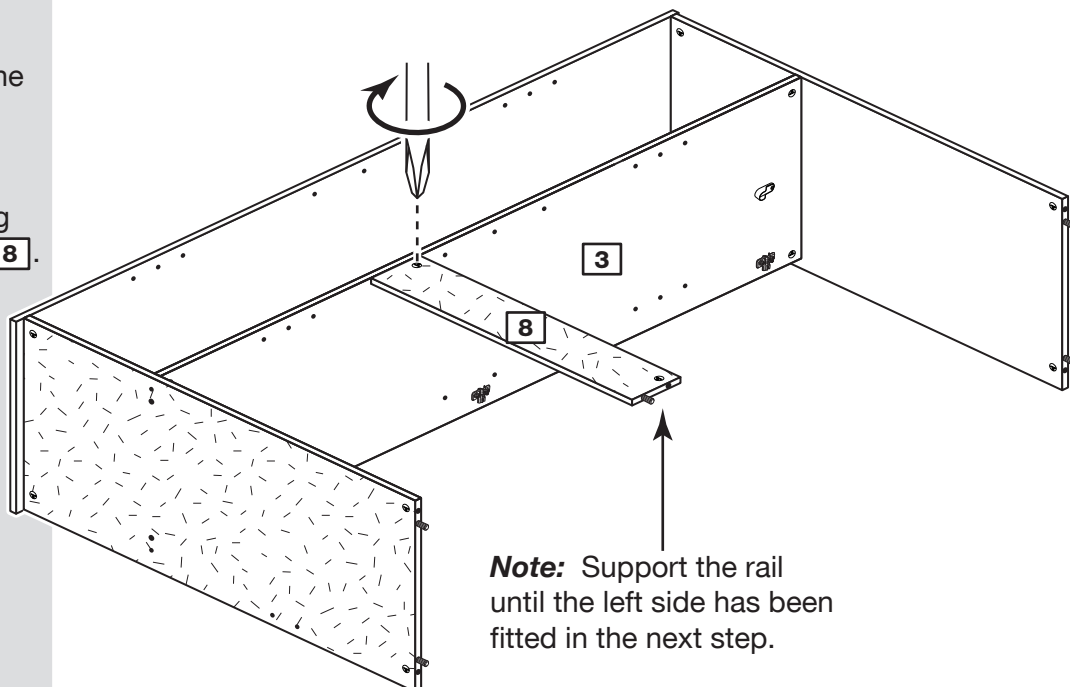

Step 10

Fit the left side

Push the left side **1** onto the assembly.

Use a screwdriver to tighten the 5 large locking nuts **C** fitted to the top **5**, base **6** and rail **8**.

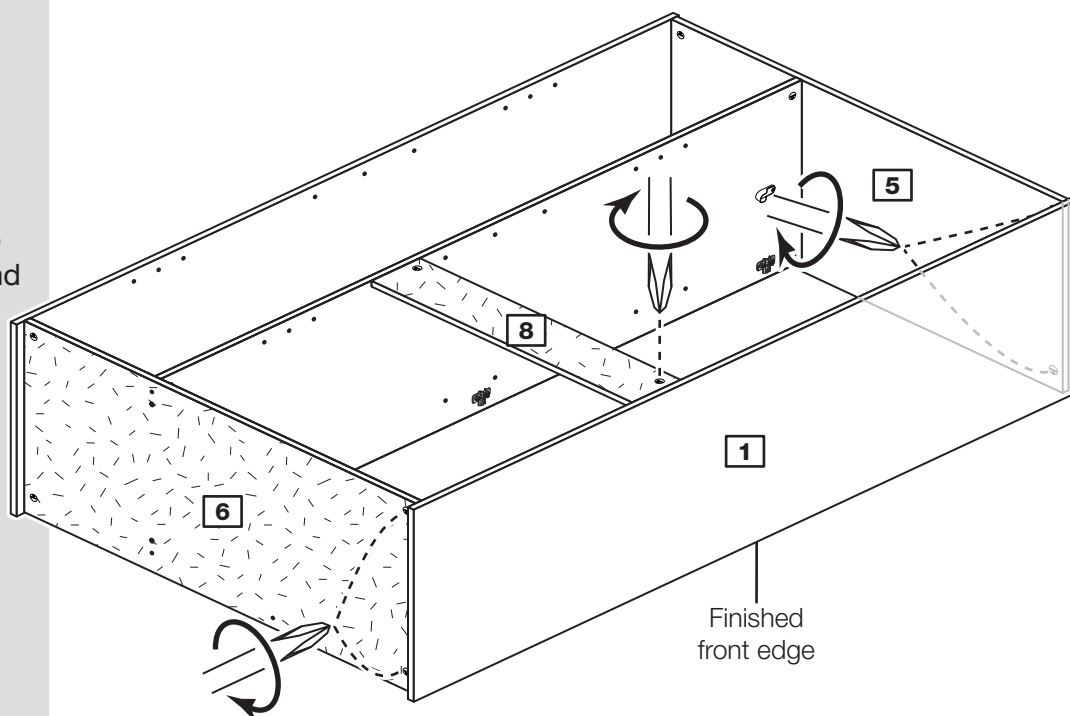

Assembly Instructions

Step 11

Fit the back panel

a: Square up the unit by making sure that measurement **x to x** equals **y to y**.

Place the small back **10** and large back **11** down onto the unit as shown, with the white surface facing the inside of the unit.

Make sure that the 2 backs are pushed up tight against each other and that they meet in the centre of the upright panel's edge.

b: Nail **H** around the outside edges only of the 2 back panels **10** and **11**.

Note: Do not nail where the backs meet. Nails should be spaced about 150mm apart.

c: Push the nail screws **M** through the back holders **N** and tap them down between the small back **10** and large back **11** and into the back edge of the divider.

Keep tapping the nail screws **M** in until the back holders **N** dig into the small and large back.

a: The measurement from top corner X to bottom corner X must be equal to the measurement from top corner Y to bottom corner Y

b:

Note: Nails should be spaced about 150mm apart.

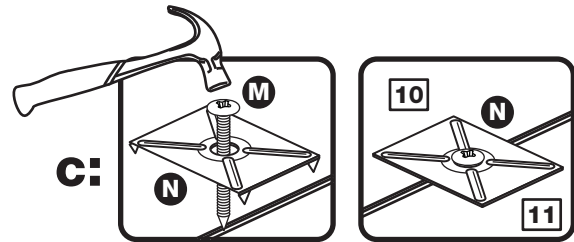

Note: These can also be round

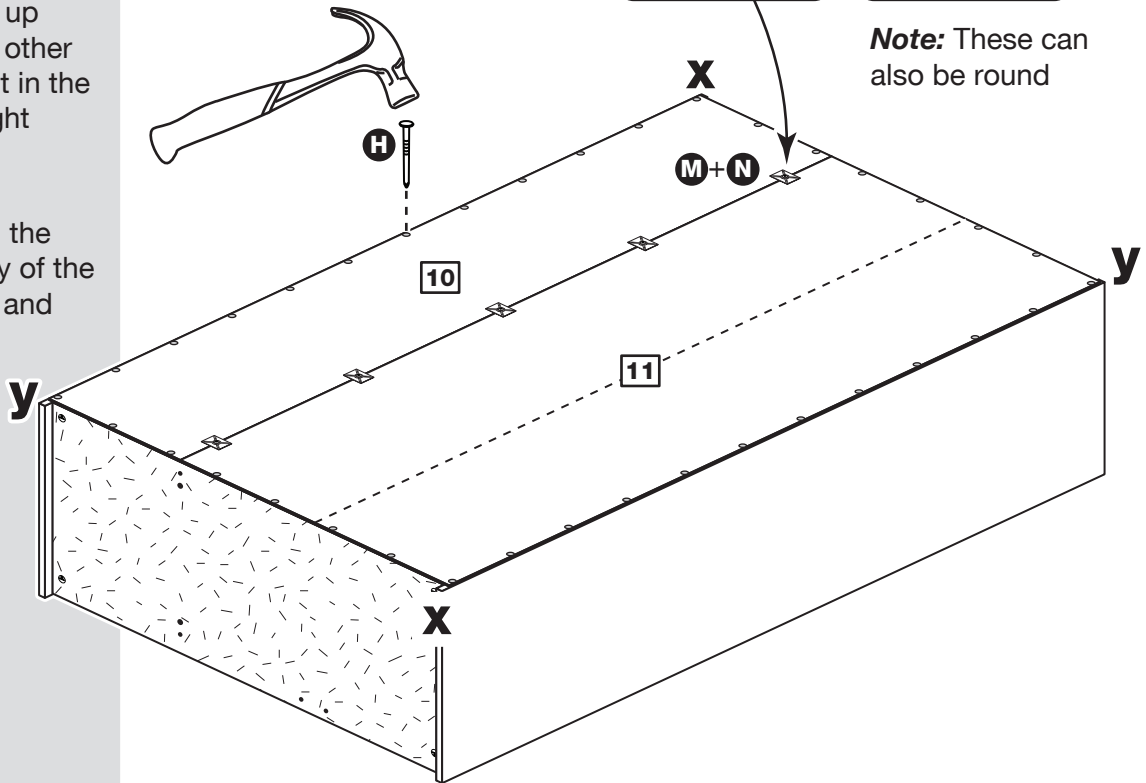

Note: If ever you need to take the backs off to dismantle the unit, the nail screws can be taken out using a screwdriver.

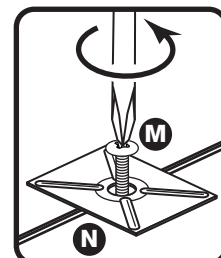

Assembly Instructions

Step 12

Fit the plastic nails

Tap 2 plastic nails **8** into the bottom edge of each of the sides **1** and **2**.

Stand the unit up for the next step.

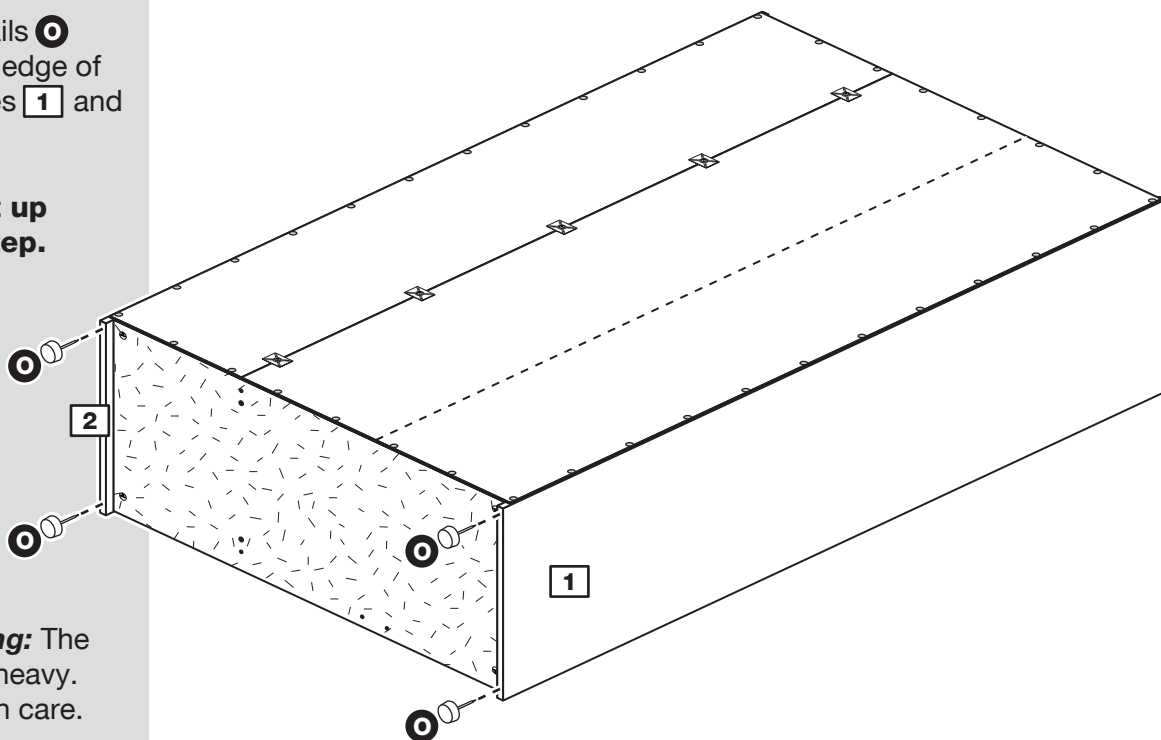

Warning: The unit is heavy. Lift with care.

Step 13

Fit the hanging rail

Push the hanging rail **9** into the rail holders **1**.

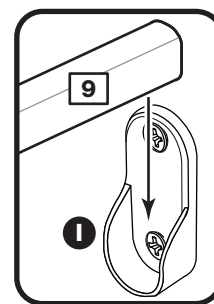
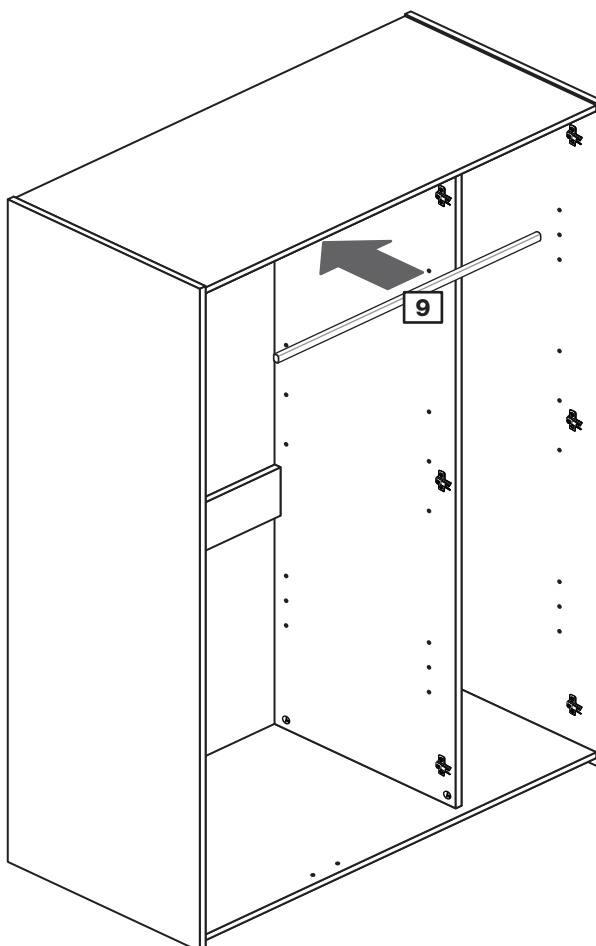

Assembly Instructions

Step 14

Fit the shelves and door stops

For each shelf **7**, insert 4 shelf studs **G** at the required height.

Lower the 3 shelves **7** down onto the shelf studs **G**.

Push the other 2 shelf studs **G** down into the holes in the base **6** to act as door stops.

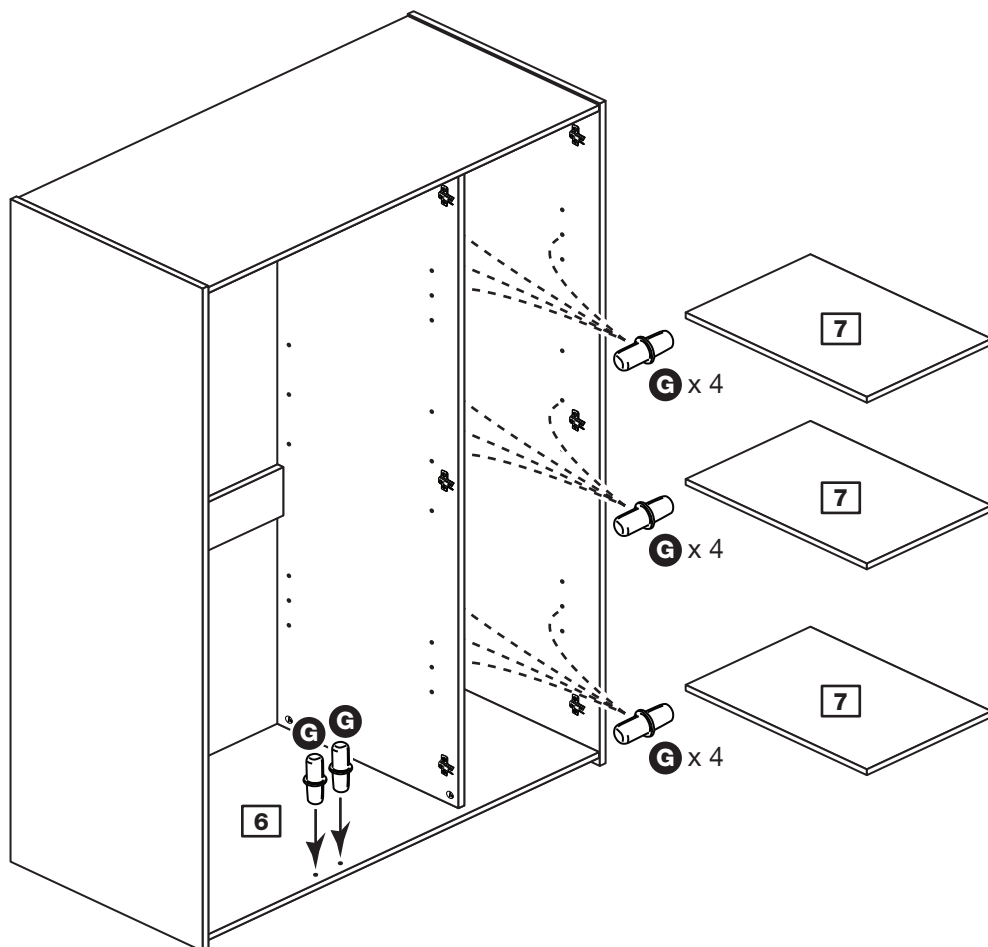

Step 15

Prepare the 3 doors

Push fit 3 hinges **L** into each of the 3 doors **4**.

Secure each hinge with 2 screws **F**.

Note: Before securing with the screws, make sure that the hinges are positioned at 90 degrees with the edge of the door.

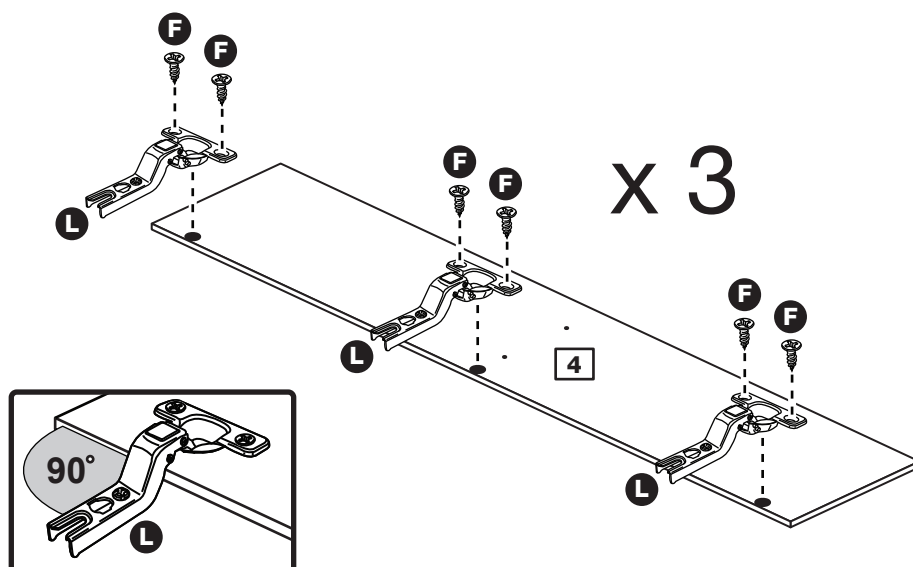

Assembly Instructions

Step 16

Fit doors and handles

Note: The easiest way to attach each door **4** is to fit the top hinge first, then align and fit the other hinges.

a: Push the hinge **L** onto the front part of the hinge plate **K**. The recess at the bottom of screw B goes into the slot in the hinge plate.

b: Keep the hinge **L** FLAT against the hinge plate **K** as you slide it across as far as it will go. Tighten screw A.

c: The hinge **L** must be flat against the hinge plate **K** prior to any adjustment.

d: The hinge **L** must NOT be AT AN ANGLE to the hinge plate **K** when assembled. This would indicate that the recess at the bottom of screw B had not located in the slot in the hinge plate and the hinge would not be secure. Remove the hinge from the hinge plate and then re-assemble being careful to follow instructions a-c.

e: Attach a handle **P** to each door **4** using 2 screws **D**.

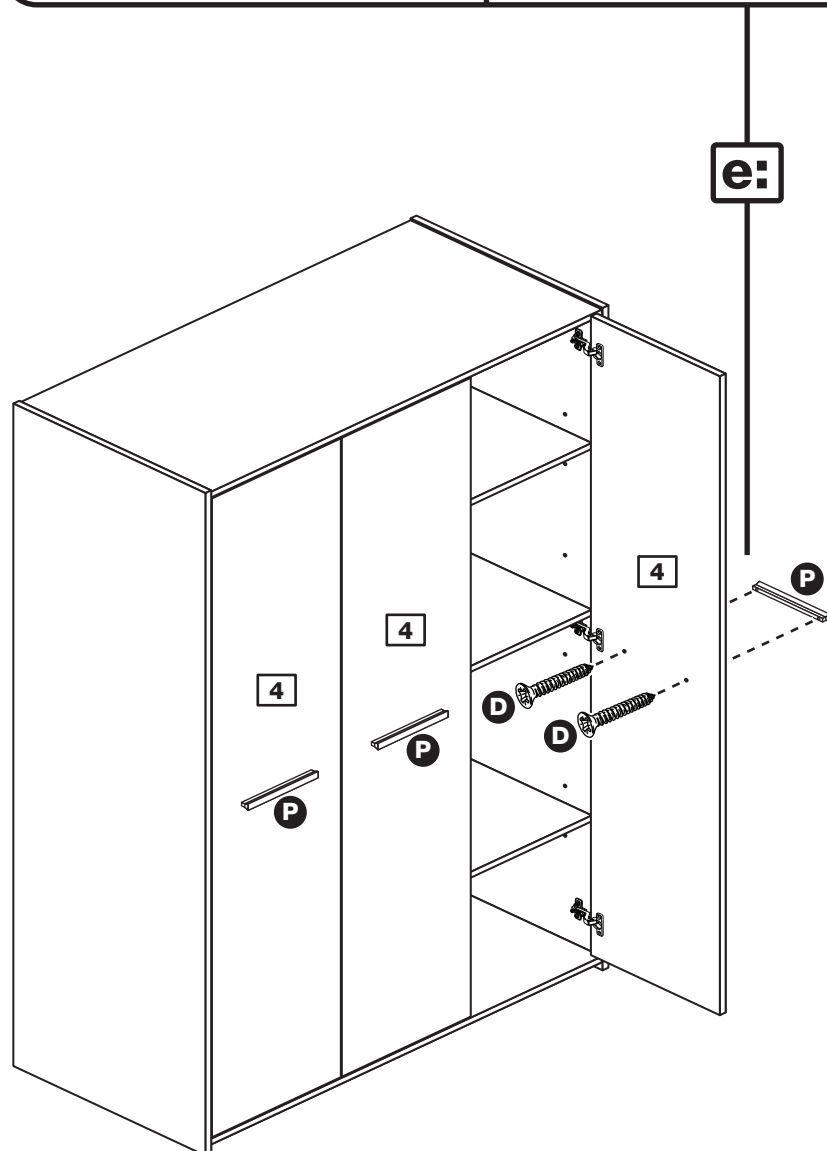
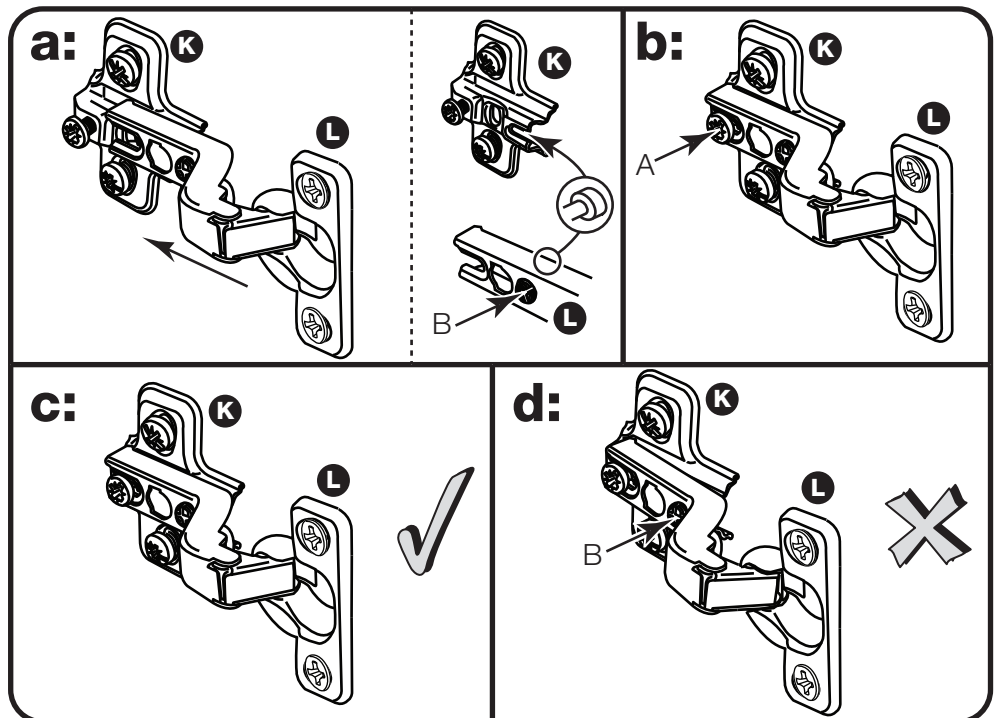

Assembly Instructions

Step 17

Adjust the doors if needed

a: Before adjusting the doors, use a spirit level to check the base (or top) of the unit is level, front-to-back and side-to-side in the 3 positions shown. Use suitable packing pieces (not supplied) to make the unit level BEFORE making any adjustment to the hinges, as shown.

b: Height adjustment.

Loosen screws A on hinge plates and move door up or down as required. Retighten screw A.

c: Forward and Back adjustment.

Loosen screw B on hinge plate and move door in or out as required. Retighten screw B.

d: Sideways adjustment.

To move door 'out' loosen screw C. To move door 'in' tighten screw C.

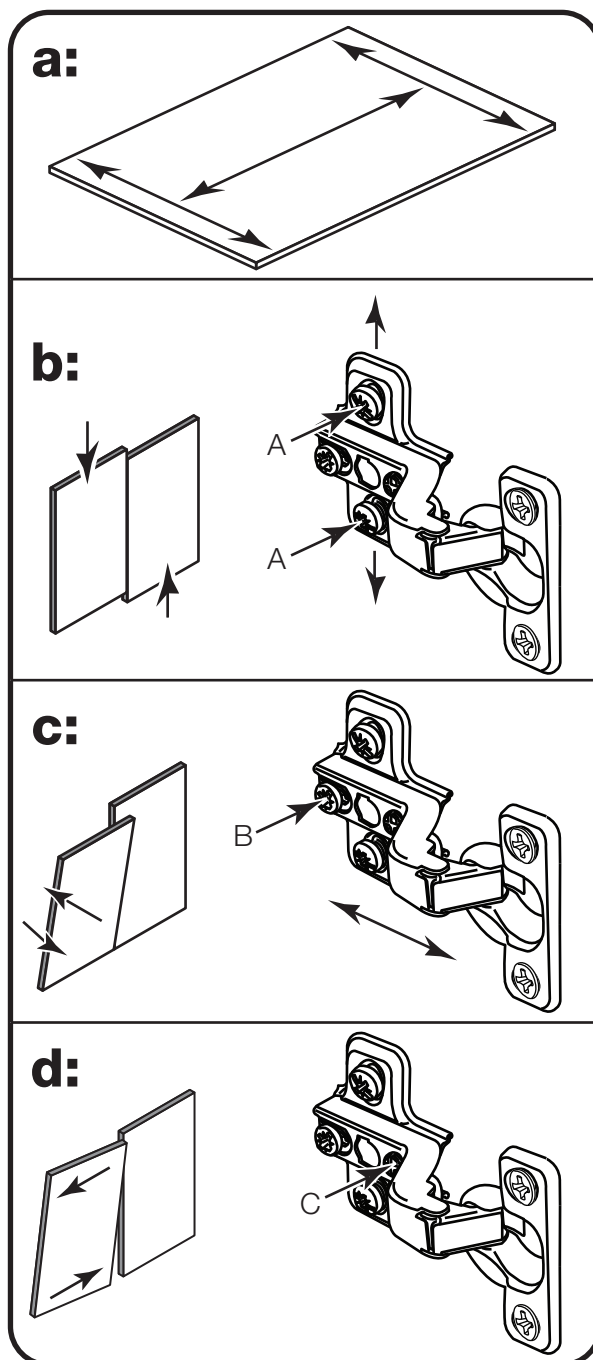

Assembly Instructions

Step 18

Fit the bracket

To prevent possible overbalancing, we recommend that this unit is secured to a suitable wall by use of the bracket **J** fitted to the top of the unit.

Fixings are not supplied, as they will need to suit the wall type and the length of screw will depend on the distance from the back of the unit to the wall.

Fix the bracket **J** loosely onto the top of the unit using screw **E** and mark the wall for the wall fixing.

Swivel the bracket **J** away from the wall and drill a hole in the wall using a suitable drill bit and fit your wall fixing.

Swivel the bracket **J** back and fix the bracket to the wall, then tighten screw **E**.

Note: Take care when drilling the wall that you do not drill into any pipes, wires etc. If in doubt, consult an expert.



Warning: The unit is heavy. Lift with care.

Assembly is complete

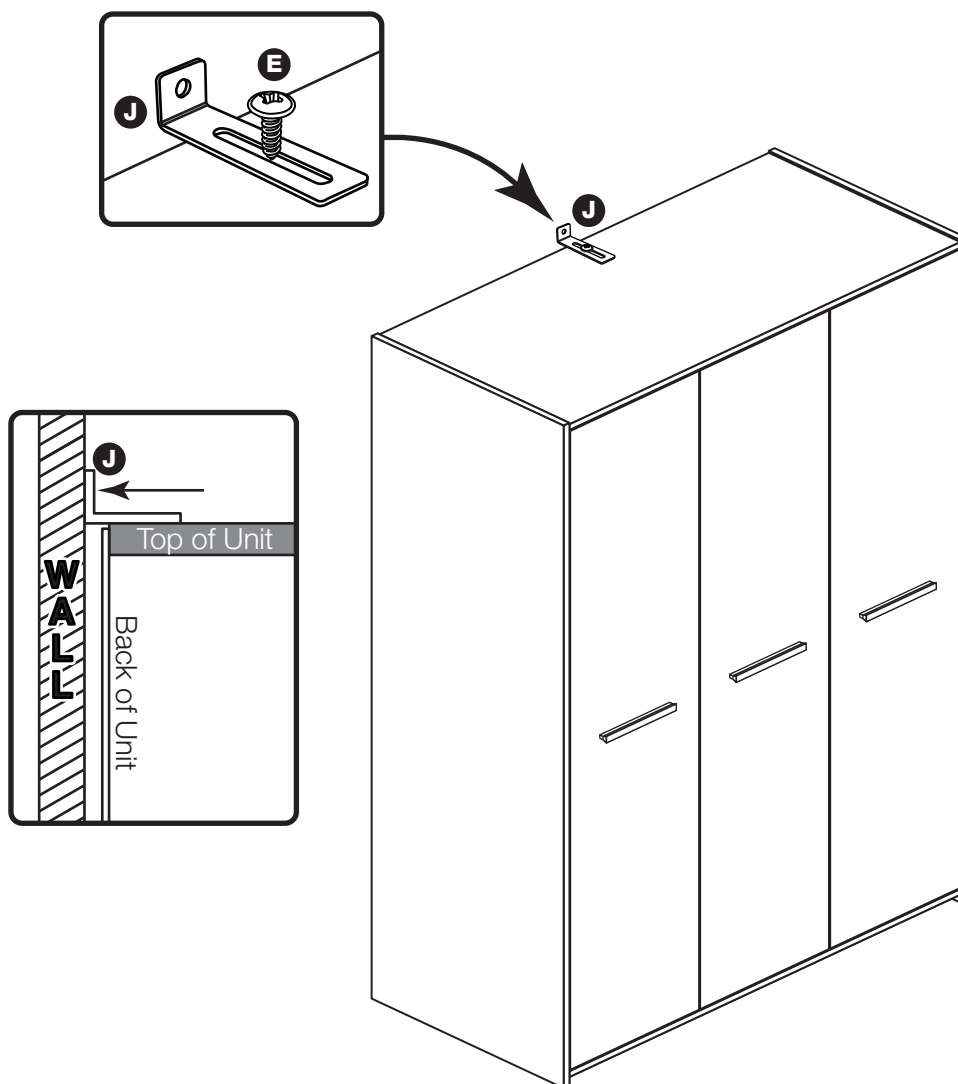

If you need help or have damaged or missing parts, call the **Customer Helpline: 08456 400800** and quote the reference numbers on the component pages.

Argos Ltd, 489-499 Avebury Boulevard, Central Milton Keynes, MK9 2NW

Kids Sywell - 3 Door Robe

Assembly Instructions - Please keep for future reference

246/7634

228/8318

238/7460

238/9341

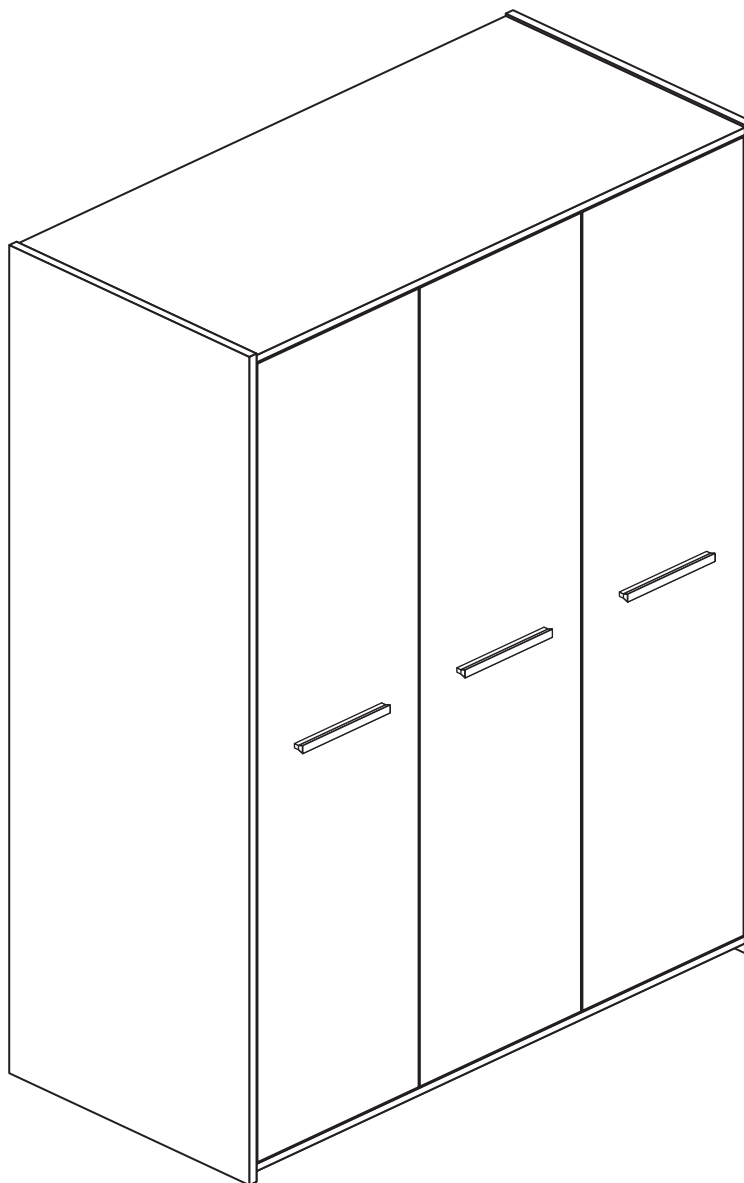

Dimensions

Width - 104cm

Depth - 50cm

Height - 172cm



**MADE IN
BRITAIN**

Important - Please read these instructions fully before starting assembly

If you need help or have damaged or missing parts, call the **Customer Helpline: 08456 400800**



Safety and Care Advice

Important - Please read these instructions fully before starting assembly

- **Warning:** This unit weighs approximately 59kgs. Please lift with care.
- Check you have all the components and tools listed on pages 2 and 3.
- Remove all fittings from the plastic bags and separate them into their groups.
- Keep children and animals away from the work area, small parts could choke if swallowed.
- Parts of the assembly will be easier with 2 people.

- Make sure you have enough space to layout the parts before starting.
- Do not stand or put weight on the product, this could cause damage.
- Assemble the item as close to its final position (in the same room) as possible.
- Assemble on a soft level surface to avoid damaging the unit or your floor (use opened out unit carton).



• We do not recommend the use of power drill/drivers **for inserting screws**, as this could damage the unit. Only use hand screwdrivers.







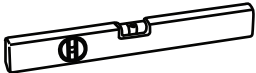

• **Safety note:** It is recommended that this unit is secured to a wall using the bracket supplied.

• Dispose of all packaging carefully and responsibly.

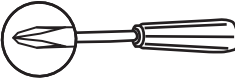
Care and maintenance

- Only clean using a damp cloth and mild detergent, do not use bleach or abrasive cleaners.
- From time to time check that there are no loose screws on this unit.
- This product should not be discarded with household waste. Take to your local authority waste disposal centre.

Tools required

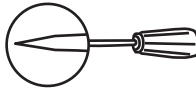
 Rule	 Spirit level	 Eye protection (when using a hammer or drill)	 Cross-head screwdriver	 Electric drill (only use when drilling into walls)	 Step ladder
 Square	 Scissors	 Hammer	 Bradawl		

Note: If required the next page can be cut out and used as reference throughout the assembly. Keep this page with these instructions for future reference.

Components - Panels

If you have damaged or missing components, call the
Customer Helpline: 08456 400800 quoting the reference
numbers below

Please check you have all the panels listed below

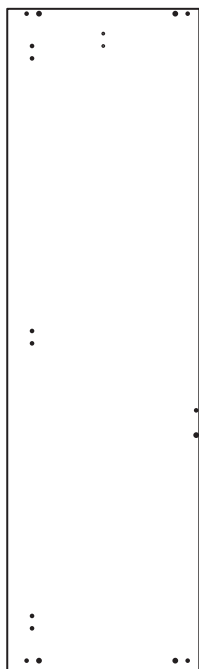

1 Left Side (D2560A)
(1711 x 496mm)

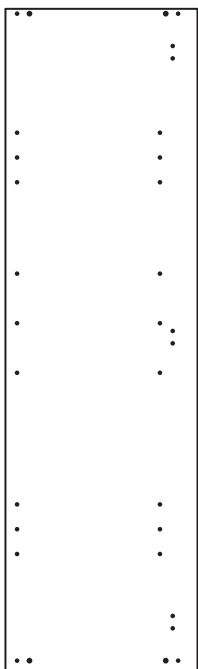

2 Right Side (D2569A)
(1711 x 496mm)

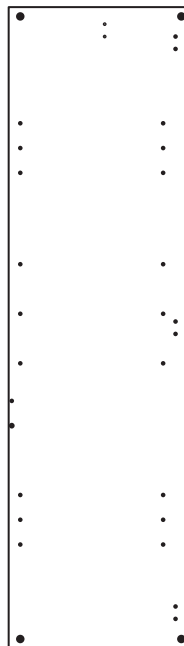

3 Upright (D2923A)
(1656 x 468mm)

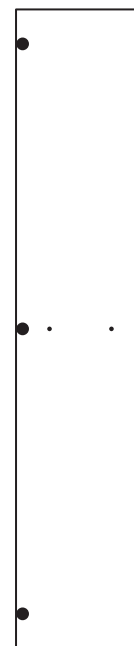

4 Door (D2563A)
(1650 x 333mm) x 3

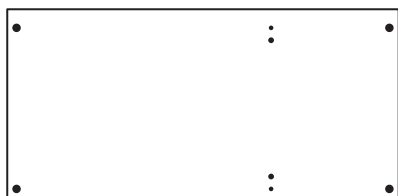

5 Top (D2568A)
(1011 x 494mm)

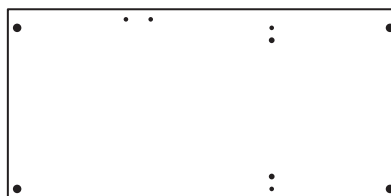

6 Base (D2922A)
(1011 x 494mm)



7 Shelf (D2574A)
(322 x 468mm) x 3

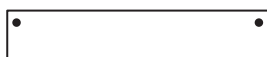

8 Rail (D2597A)
(674 x 125mm)



9 Hanging Rail (FHR666)
(666mm long)



10 Small Back (X1682-340)
(1682 x 340mm)

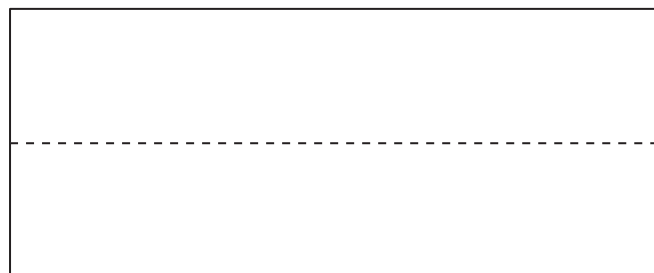

11 Large Back (X1682-694)
(1682 x 694mm)









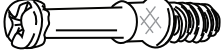

Components - Fittings

If you have damaged or missing components, call the **Customer Helpline: 08456 400800** quoting the reference numbers below

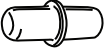
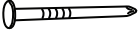
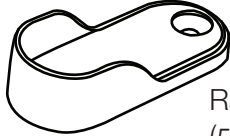
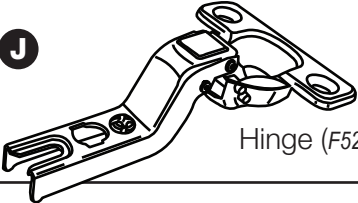
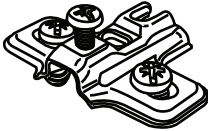
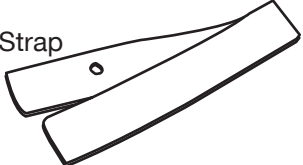
Please check you have all the fittings listed below

Note: The quantities below are the correct amount to complete the assembly. In some cases more fittings may be supplied than are required.

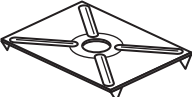
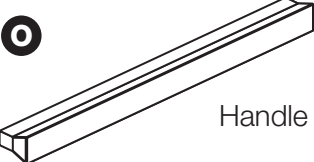
<p>A </p> <p>Wooden dowel (F22) x 14</p>	<p>B </p> <p>Metal dowel (F901) x 14</p>	<p>C </p> <p>Large locking nut (F900) x 14</p>
<p>D </p> <p>25mm Screw (F95) x 6</p>	<p>E </p> <p>Plastic Nail (F91) x 4</p>	<p>F </p> <p>13mm Screw (F63) x 22</p>
<p>G </p> <p>Shelf stud (F110) x 14</p>	<p>H </p> <p>Nail (F51) x 36</p>	<p>I </p> <p>Rail Holder (F891) x 2</p>
<p>J </p> <p>Hinge (F522) x 9</p>	<p>K </p> <p>Hinge plate (F523) x 9</p>	<p>L </p> <p>Strap</p> <p> Screw  Washer x 2</p> <p>Overbalance protector kit (F269) x 1</p>
<p>M </p> <p>Nail screw (F277) x 5</p>	<p>N </p> <p>Back holder (F276) x 5</p> <p>*These can also be round</p>	
<p>O </p> <p>Handle (F315) x 3</p>		

Ruler - Use this ruler to help correctly identify the screws

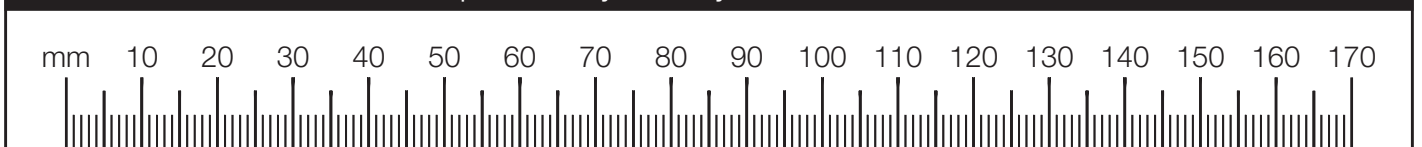

Assembly Instructions

If you have damaged or missing components, call the Customer Helpline: 08456 400800 quoting the reference numbers below

Step 1

Prepare the upright

a: Insert 4 large locking nuts **C** into the upright **3**.

Note: The arrow on the locking nut **must** point towards the hole in the edge of the panel.

Tap 4 wooden dowels **A** into the upright **3**.

Note: Wooden dowels **must not** stick out from the edge by more than 10mm or they may damage other panels.

Screw a metal dowel **B** into the upright **3**.

Note: Tighten the metal dowel up fully against the panel.

b: Fit 3 hinge plates **K** onto the upright **3**, making sure that the slot is facing towards the finished front edge.

Fit the rail holder **I** to the upright **3** using 2 screws **F**.

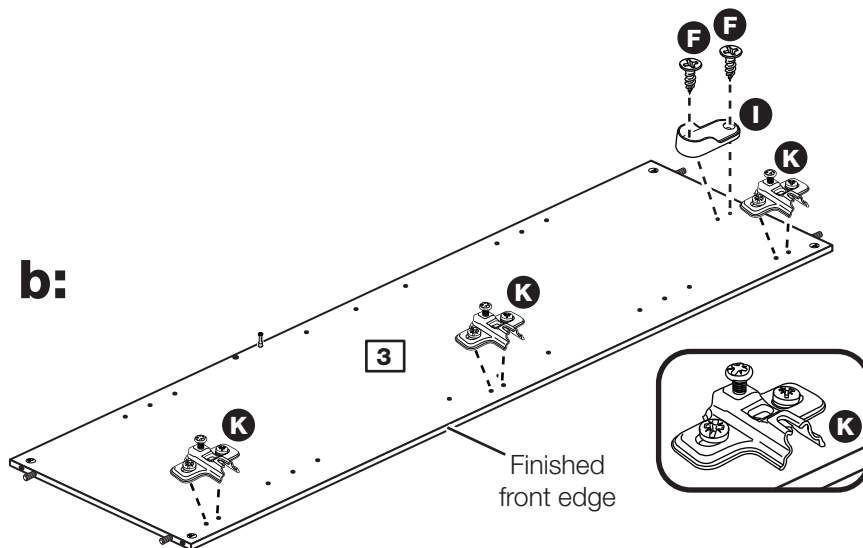
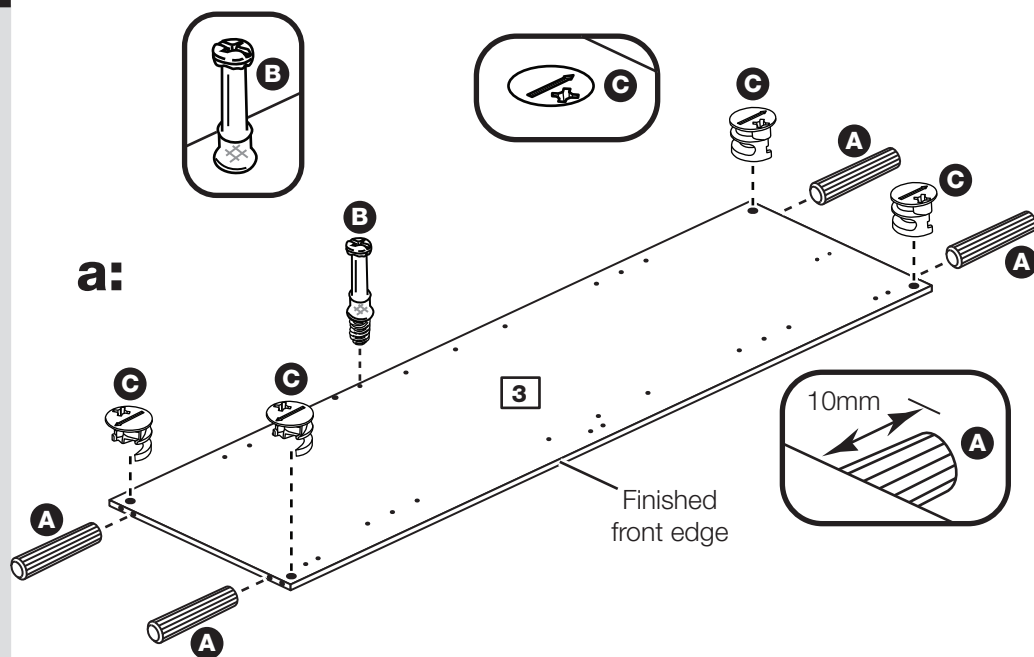

Assembly Instructions

Step 2

Prepare the top

Tap 4 wooden dowels **A** into the top **5**.

Insert 4 large locking nuts **C** into the top **5**.

Screw 2 metal dowels **B** into the top **5**.

Note: Tighten the metal dowels up fully against the panels.

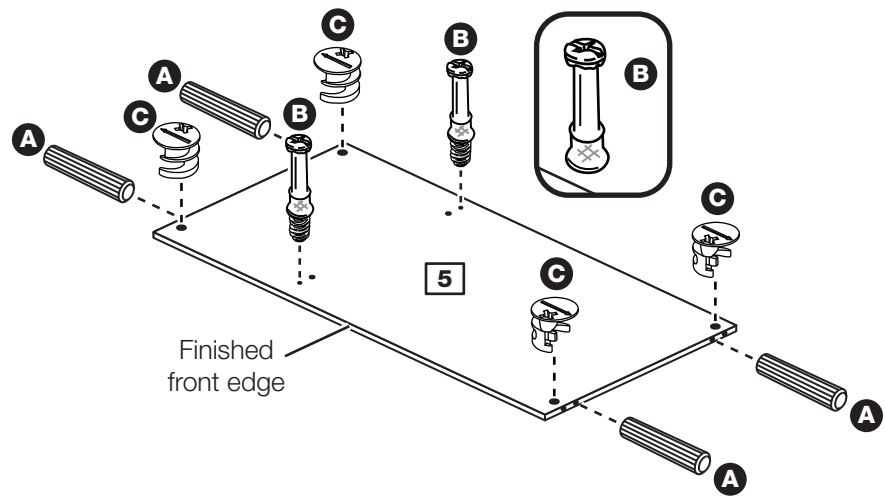

Step 3

Prepare the base

a: Tap 4 wooden dowels **A** into the base **6**.

Insert 4 large locking nuts **C** into the base **6**.

Turn the base over

b: Screw 2 metal dowels **B** into the base **6**.

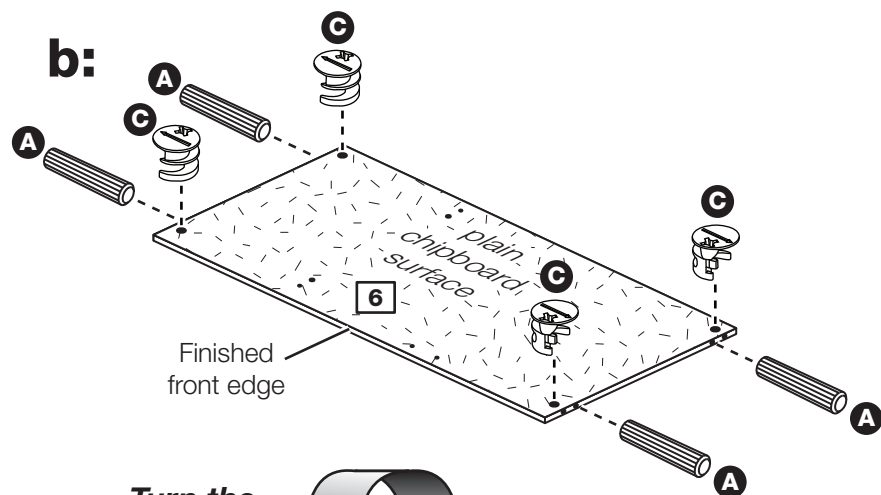

Turn the base over

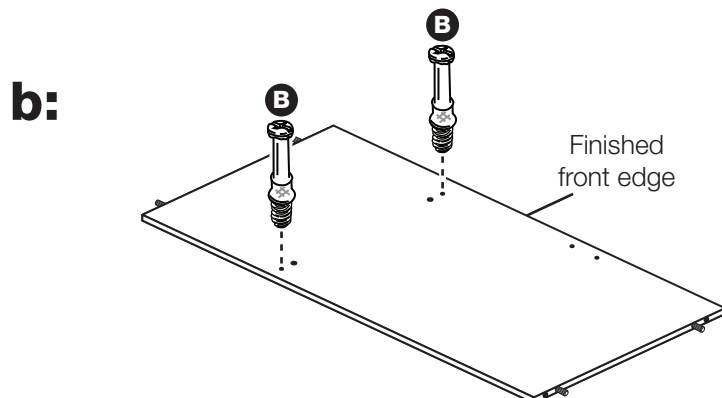

Assembly Instructions

Step 4

Fit the top and base to the upright

Push the top **5** and the base **6** onto the upright **3**.

Use a screwdriver to tighten the 4 large locking nuts **C** fitted to the upright **3**.

Note: Turn the large locking nuts **C** as far as they will go - more than 1/2 a turn.

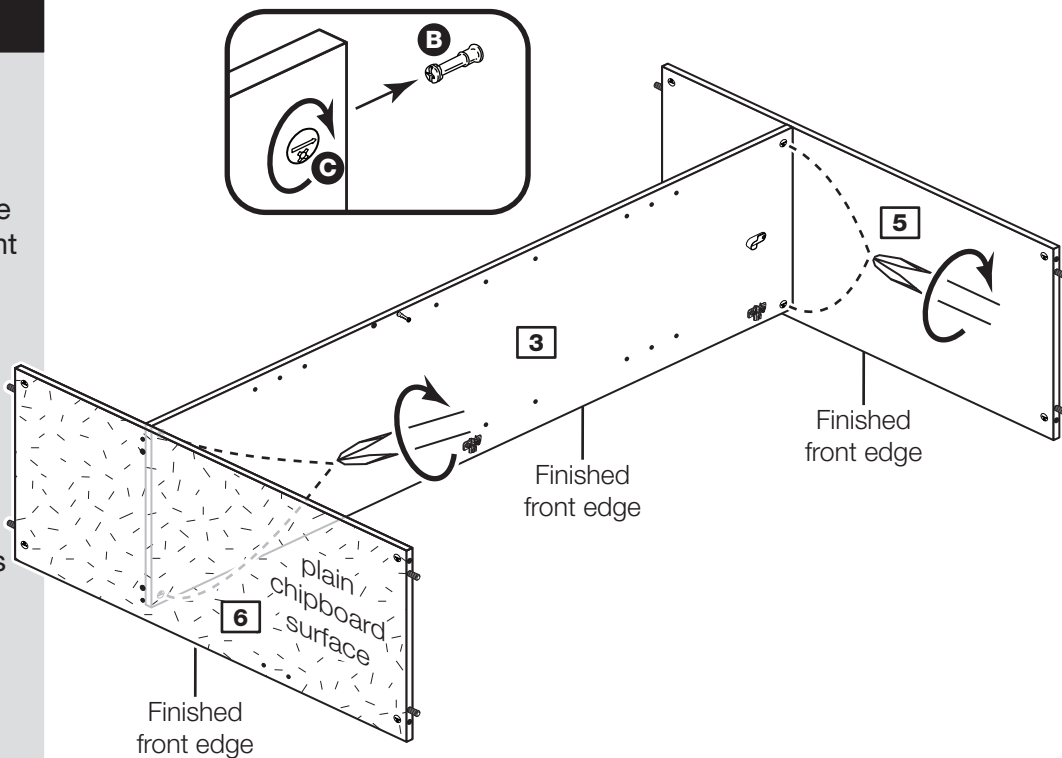

Step 5

Prepare the left side

Screw 5 metal dowels **B** into the left side **1**.

Note: Tighten the metal dowels up fully against the panels.

Fit 3 hinge plates **K** onto the left side **1**, making sure that the slot is facing towards the finished front edge.

Fit the rail holder **I** to the left side **1** using 2 screws **F**.

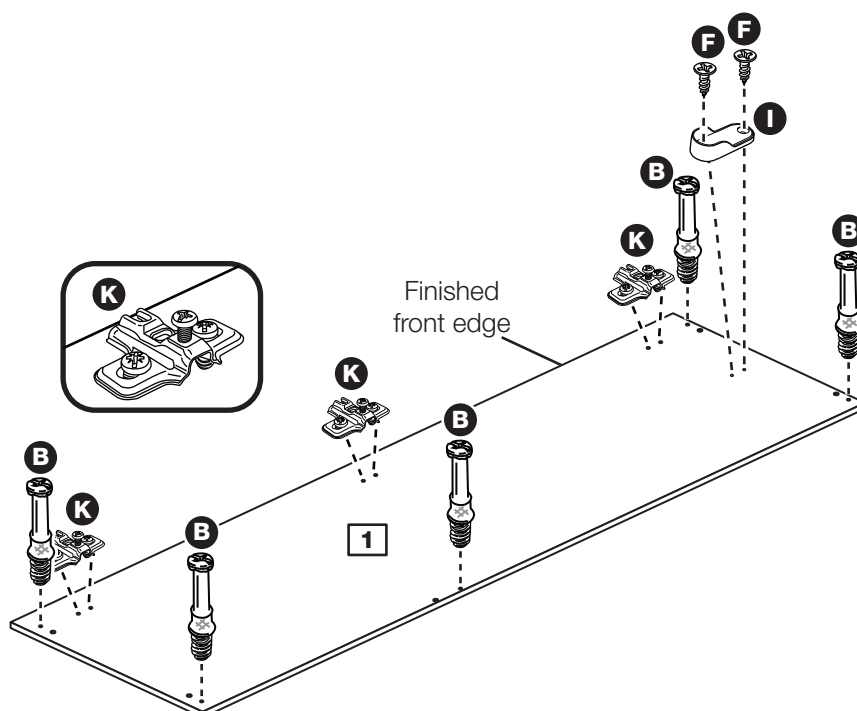

Assembly Instructions

Step 6

Prepare the right side

Screw 4 metal dowels **B** into the right side **2**.

Fit 3 hinge plates **K** onto the right side **2**, making sure that the slot is facing towards the finished front edge.

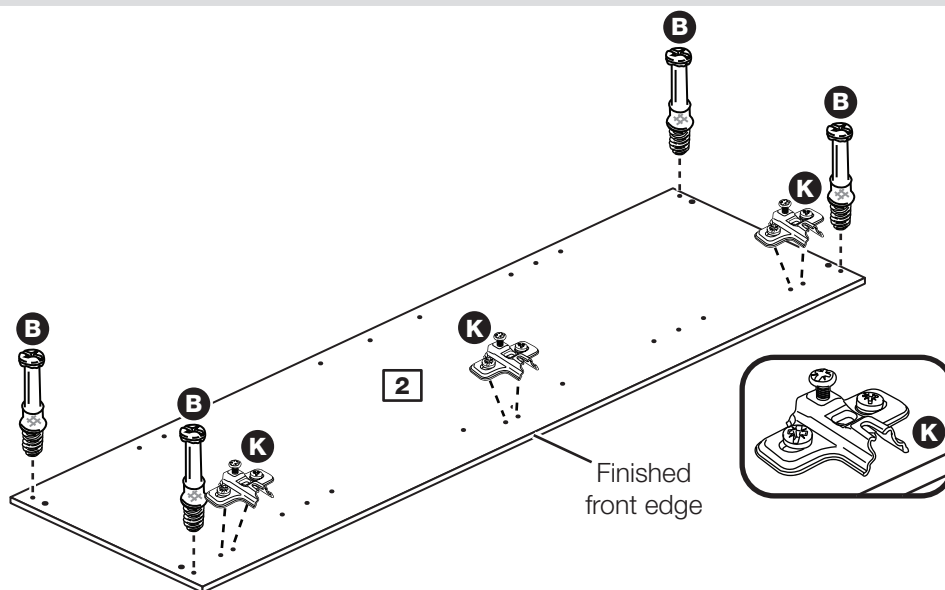

Step 7

Fit the right side

Push the right side **2** onto the top **5** and base **6**.

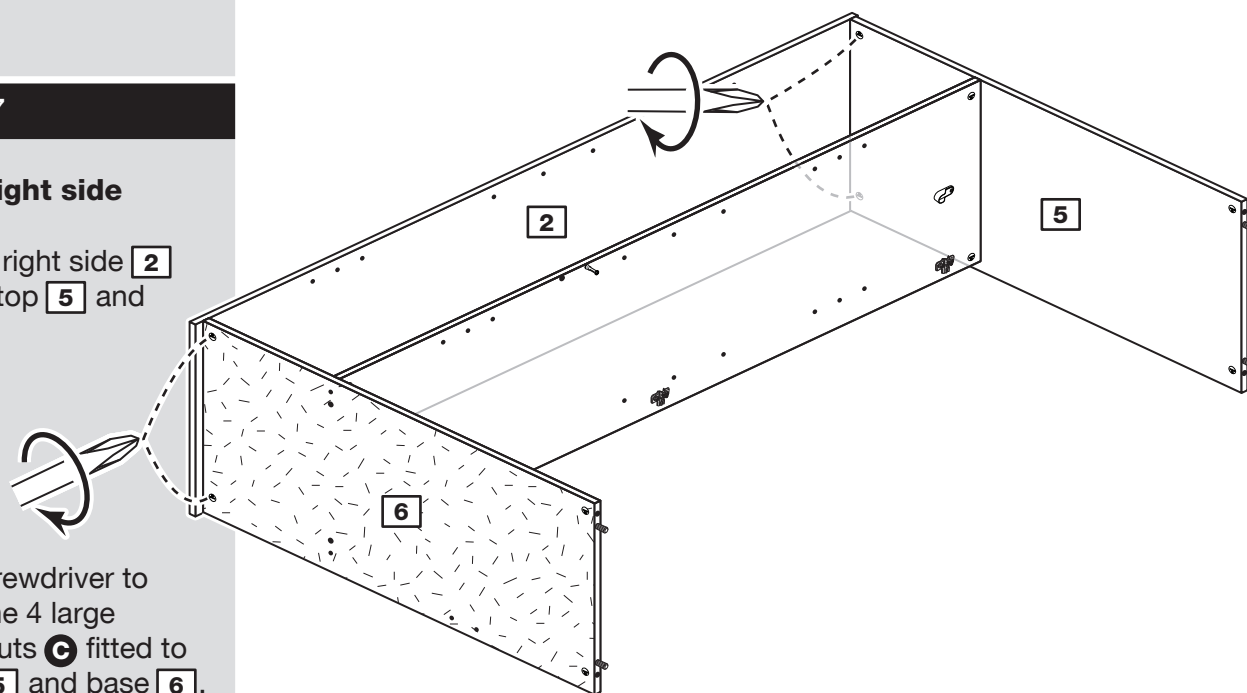

Use a screwdriver to tighten the 4 large locking nuts **C** fitted to the top **5** and base **6**.

Step 8

Prepare the rail

Tap 2 wooden dowels **A** into the rail **8**.

Insert 2 large locking nuts **C** into the rail **8**.

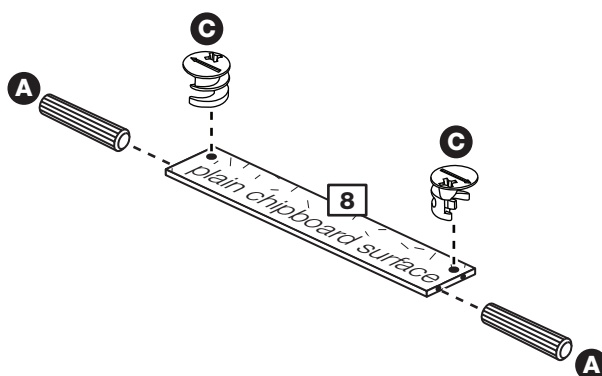

Assembly Instructions

Step 9

Fit the rail

Push the rail **8** onto the upright **3**.

Use a screwdriver to tighten the large locking nut **C** fitted to the rail **8**.

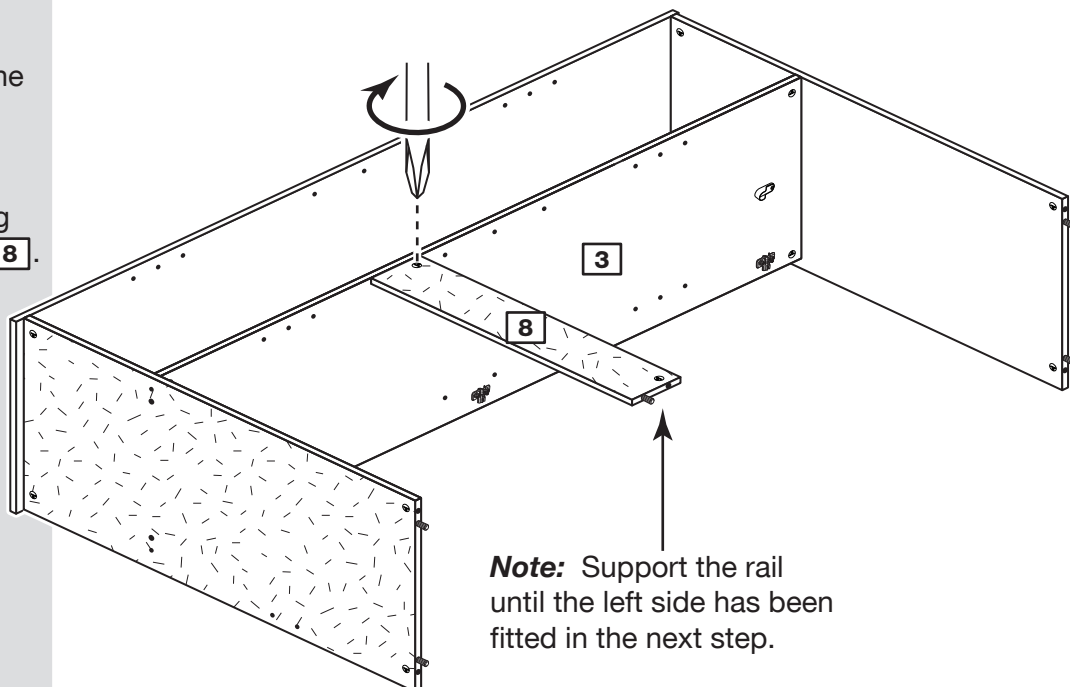

Step 10

Fit the left side

Push the left side **1** onto the assembly.

Use a screwdriver to tighten the 5 large locking nuts **C** fitted to the top **5**, base **6** and rail **8**.

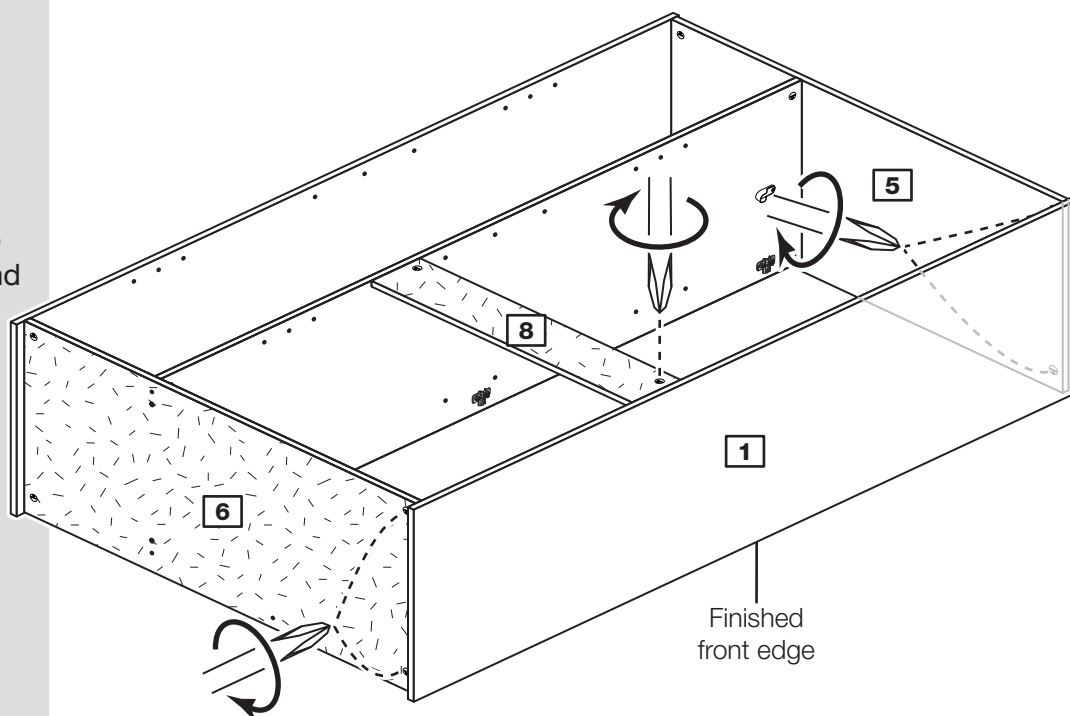

Assembly Instructions

Step 11

Fit the back panel

a: Square up the unit by making sure that measurement **x to x** equals **y to y**.

Place the small back **10** and large back **11** down onto the unit as shown, with the white surface facing the inside of the unit.

Make sure that the 2 backs are pushed up tight against each other and that they meet in the centre of the upright panel's edge.

b: Nail **H** around the outside edges only of the 2 back panels **10** and **11**.

Note: Do not nail where the backs meet. Nails should be spaced about 150mm apart.

c: Push the nail screws **M** through the back holders **N** and tap them down between the small back **10** and large back **11** and into the back edge of the divider.

Keep tapping the nail screws **M** in until the back holders **N** dig into the small and large back.

a: The measurement from top corner X to bottom corner X must be equal to the measurement from top corner Y to bottom corner Y

b:

Note: Nails should be spaced about 150mm apart.

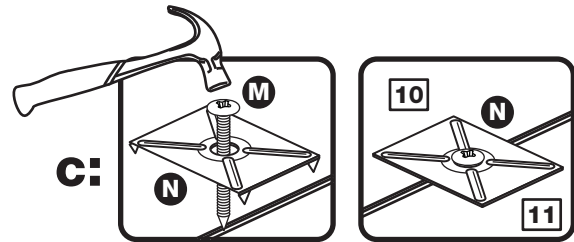

Note: These can also be round

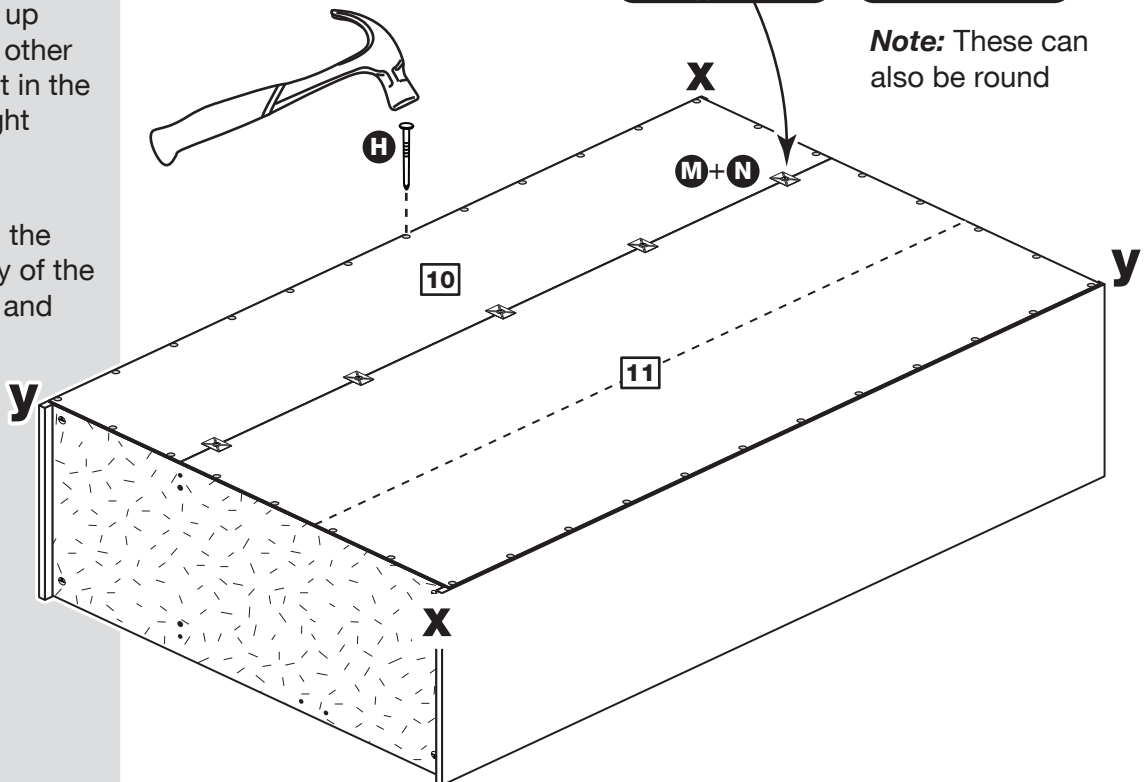

Note: If ever you need to take the backs off to dismantle the unit, the nail screws can be taken out using a screwdriver.

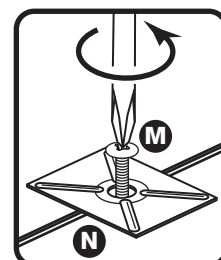

Assembly Instructions

Step 12

Fit the plastic nails

Tap 2 plastic nails **E** into the bottom edge of each of the sides **1** and **2**.

Stand the unit up for the next step.

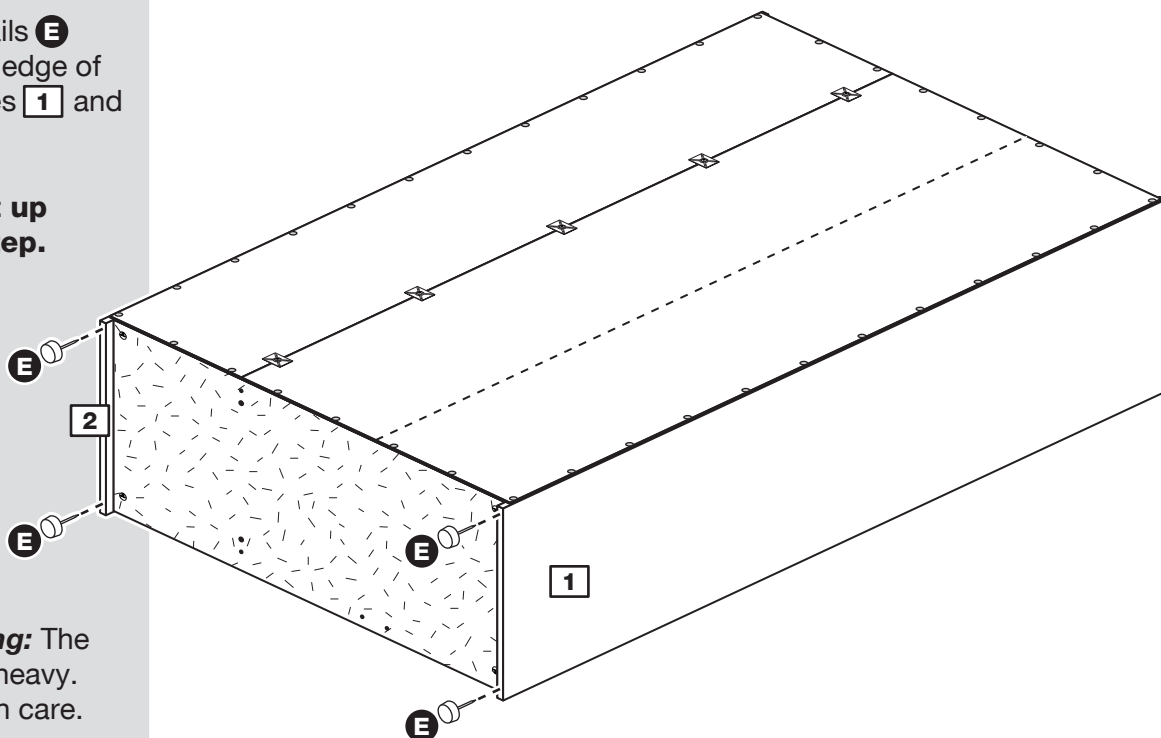

Warning: The unit is heavy. Lift with care.

Step 13

Fit the hanging rail

Push the hanging rail **9** into the rail holders **1**.

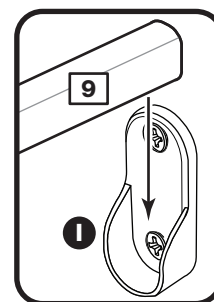
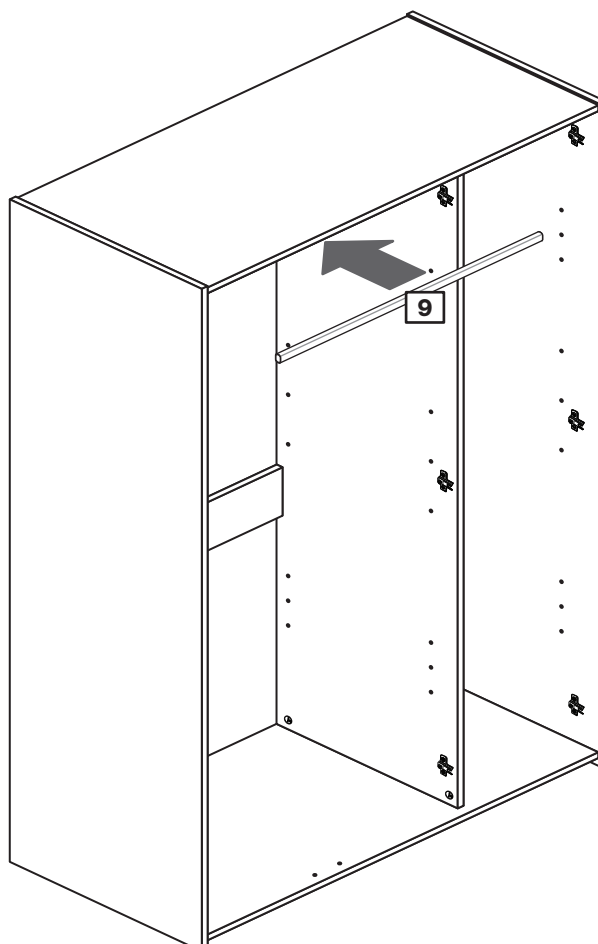

Assembly Instructions

Step 14

Fit the shelves and door stops

For each shelf **7**, insert 4 shelf studs **G** at the required height.

Lower the 3 shelves **7** down onto the shelf studs **G**.

Push the other 2 shelf studs **G** down into the holes in the base **6** to act as door stops.

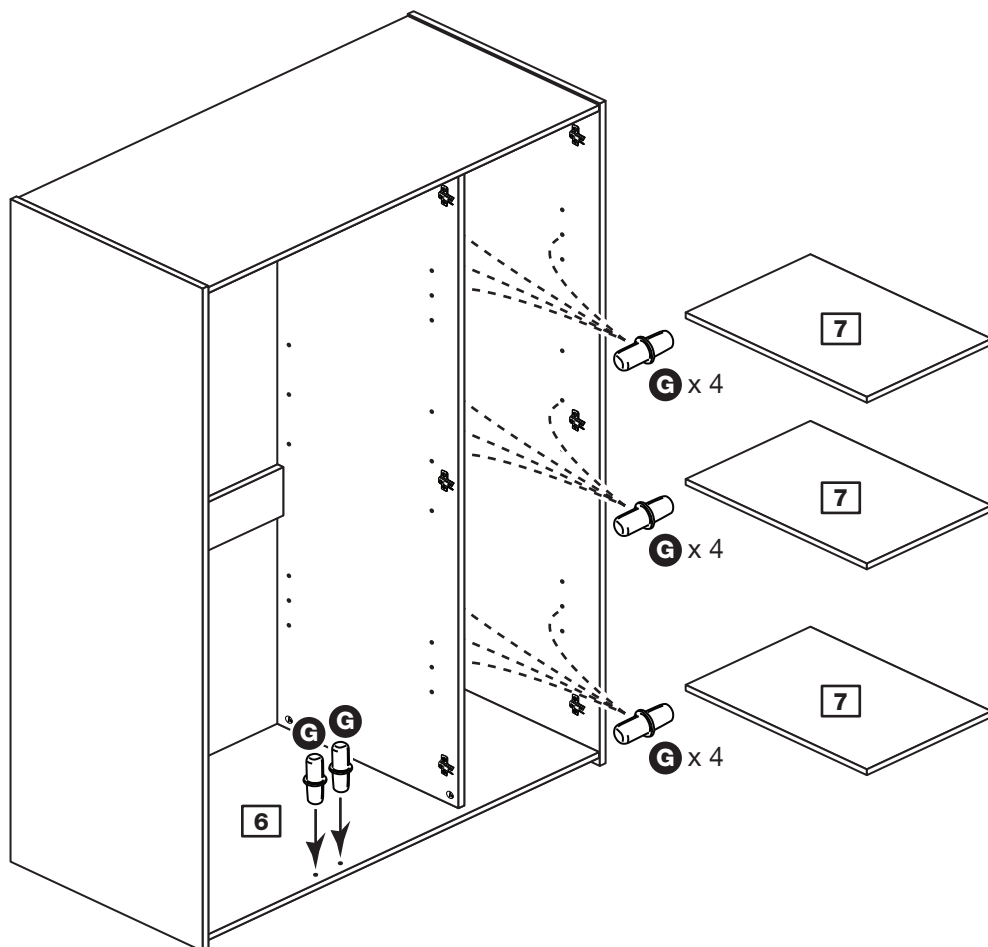

Step 15

Prepare the 3 doors

Push fit 3 hinges **J** into each of the 3 doors **4**.

Secure each hinge with 2 screws **F**.

Note: Before securing with the screws, make sure that the hinges are positioned at 90 degrees with the edge of the door.

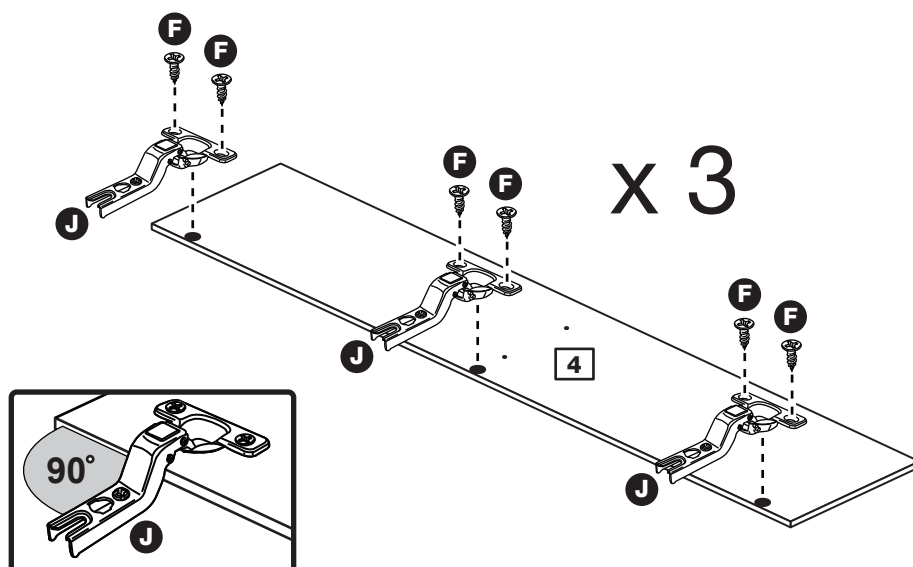

Assembly Instructions

Step 16

Fit doors and handles

Note: The easiest way to attach each door **4** is to fit the top hinge first, then align and fit the other hinges.

a: Push the hinge **J** onto the front part of the hinge plate **K**. The recess at the bottom of screw B goes into the slot in the hinge plate.

b: Keep the hinge **J** FLAT against the hinge plate **K** as you slide it across as far as it will go. Tighten screw A.

c: The hinge **J** must be flat against the hinge plate **K** prior to any adjustment.

d: The hinge **J** must NOT be AT AN ANGLE to the hinge plate **K** when assembled. This would indicate that the recess at the bottom of screw B had not located in the slot in the hinge plate and the hinge would not be secure. Remove the hinge from the hinge plate and then re-assemble being careful to follow instructions a-c.

e: Attach a handle **O** to each door **4** using 2 screws **D**.

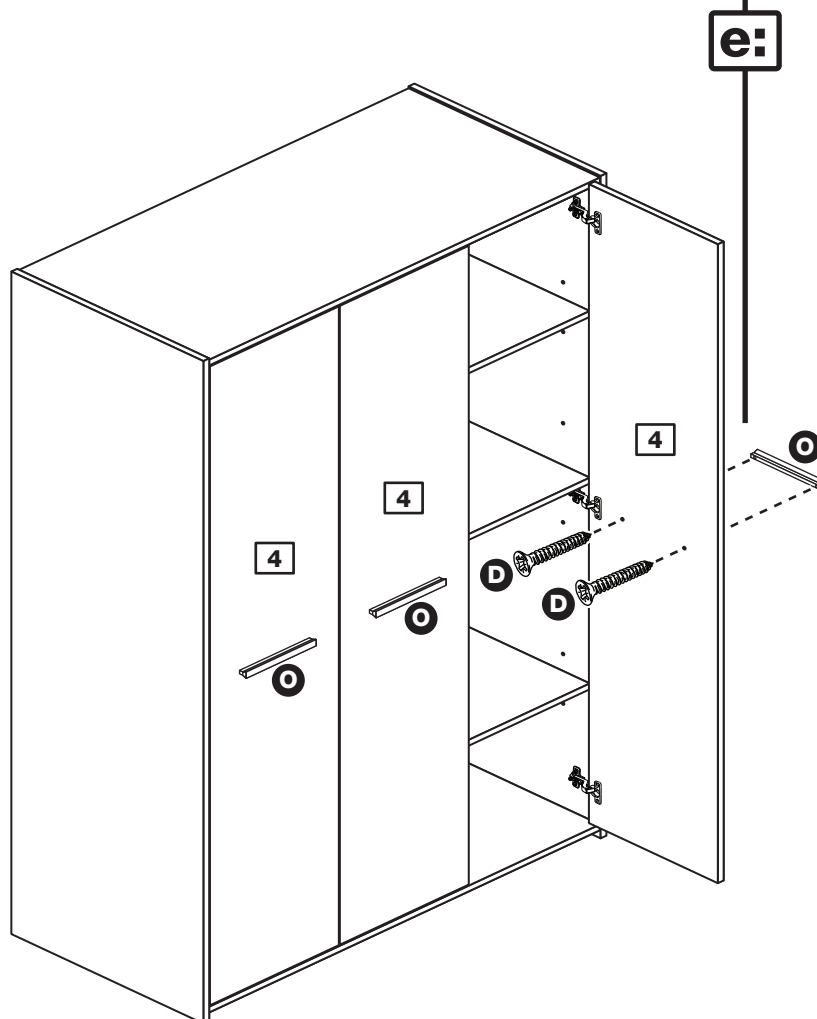
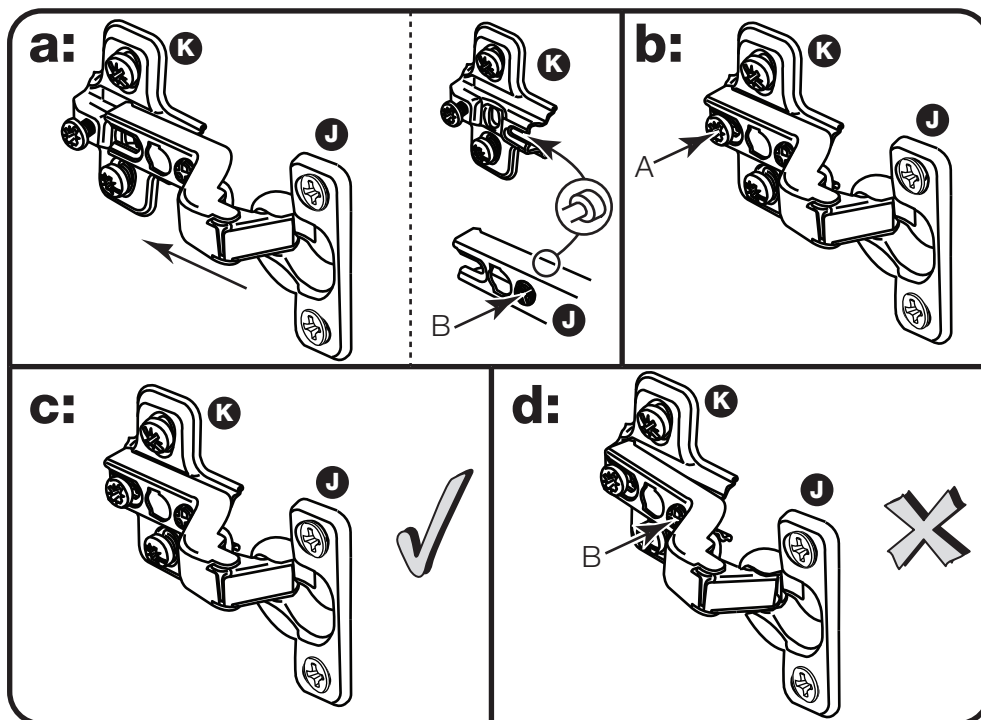

Assembly Instructions

Step 17

Adjust the doors if needed

a: Before adjusting the doors, use a spirit level to check the base (or top) of the unit is level, front-to-back and side-to-side in the 3 positions shown. Use suitable packing pieces (not supplied) to make the unit level BEFORE making any adjustment to the hinges, as shown.

b: Height adjustment.

Loosen screws A on hinge plates and move door up or down as required. Retighten screw A.

c: Forward and Back adjustment.

Loosen screw B on hinge plate and move door in or out as required. Retighten screw B.

d: Sideways adjustment.

To move door 'out' loosen screw C. To move door 'in' tighten screw C.

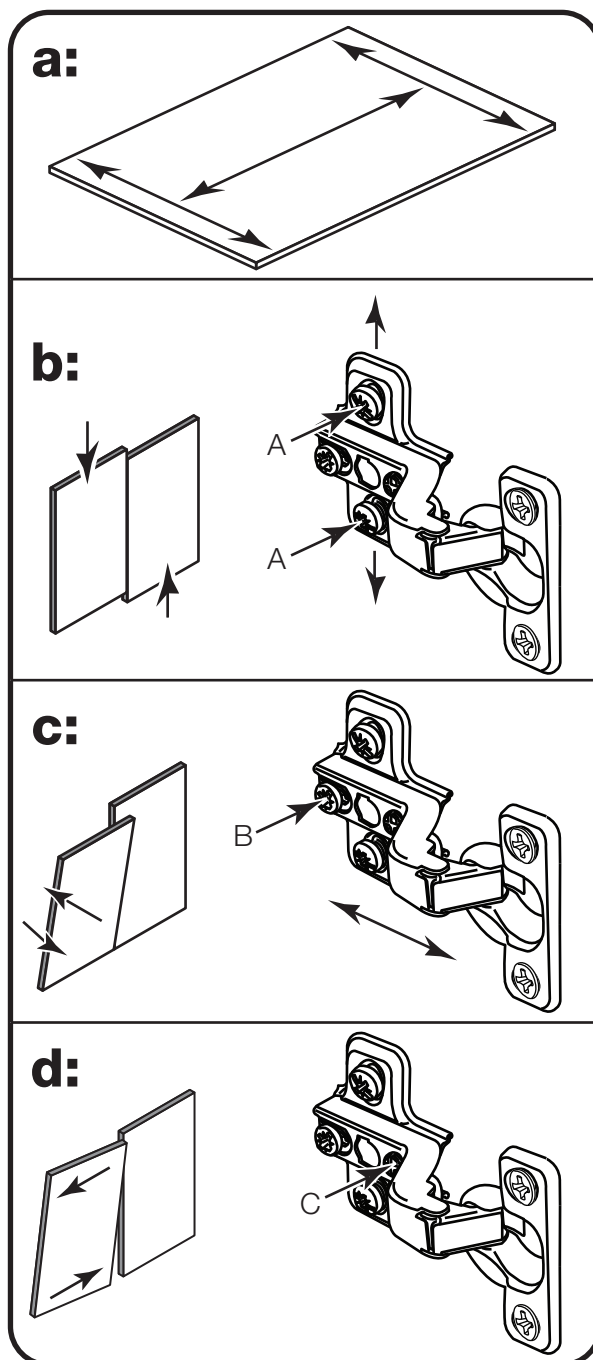

Assembly Instructions

Step 18

Fit the overbalance protector

To prevent possible overbalancing we recommend that this unit is secured to a suitable wall by use of the overbalance protector kit **L** fitted to the unit or, an alternative fixing method of your choice.

Wall fixings are not supplied as they will need to suit the wall type.

Note: Take care when drilling the wall that you do not drill into any pipes, wires etc. If in doubt, consult an expert.

Assembly is complete

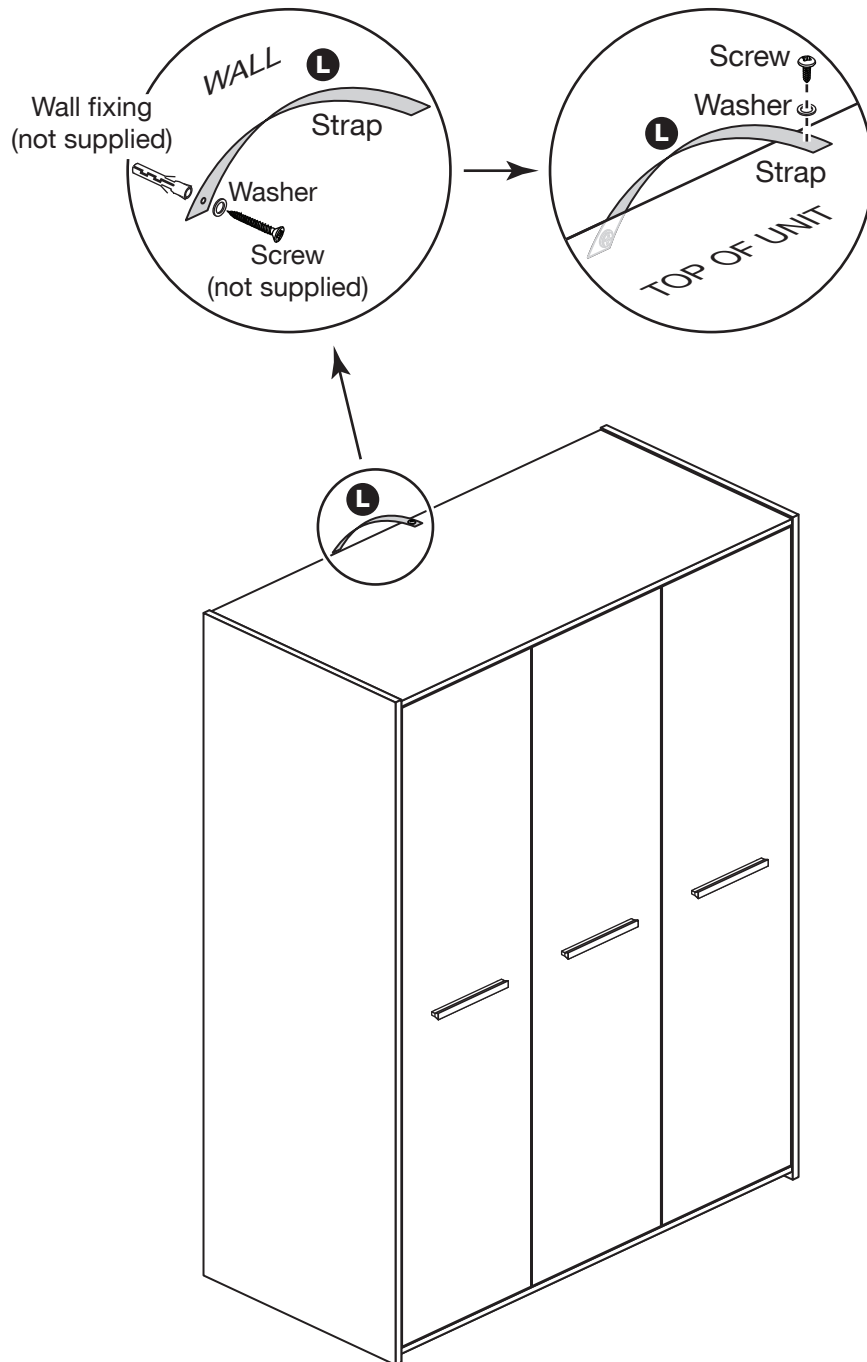

If you need help or have damaged or missing parts, call the Customer Helpline: 08456 400800 and quote the reference numbers on the component pages.

Argos Ltd, 489-499 Avebury Boulevard, Central Milton Keynes, MK9 2NW

