

Bergen 120 Foil/ foil

Assembly Instructions Please keep for future reference

258/1417

257/1740

258/5963

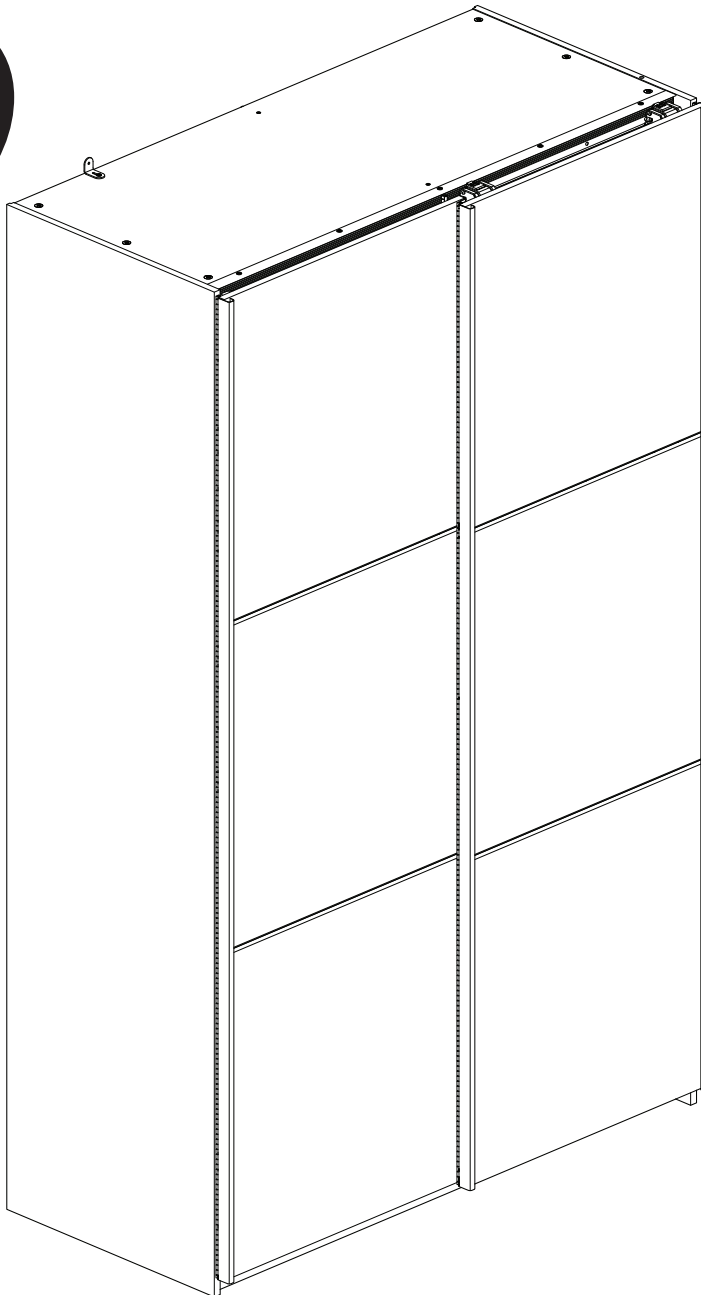
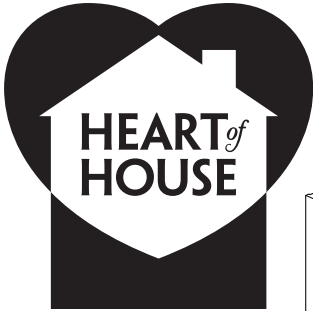

Dimensions

Width - 120cm
Depth - 59.5cm
Height - 199.8cm

**Tip : To prevent damage,
we recommend that you
build your unit on the
carton(s) it was packed in.**

258/1417 OAK
258/5963 WAL
257/1740 WHT

Important – Please read these instructions fully before starting assembly

If you need help or have damaged or missing parts, please visit: www.argos-support.co.uk
or email: Help@ClickSpares.co.uk (quoting your original order number)
Alternatively, call the Spares Helpline on: **0370 112 1928**
For any other queries please contact the Customer Helpline on: **0345 640 2020**



Safety and Care Advice

Important – Please read these instructions fully before starting assembly

- Check you have all the components and tools listed on pages 2 and 3.
- Remove all fittings from the plastic bags and separate them into their groups.
- Keep children and animals away from the work area, small parts could choke if swallowed.
- Make sure you have enough space to layout the parts before starting.

- Do not stand or put weight on the product, this could cause damage.
- Assemble the item as close to its final position (in the same room) as possible.
- Assemble on a soft level surface to avoid damaging the unit or your floor.
- Parts of the assembly will be easier with 2 people.



• To reduce the likelihood of damaging your product please ensure that your power drill is set on a low torque setting.

- Dispose of all packaging carefully and responsibly.

Care and maintenance

- Only clean using a damp cloth and mild detergent, do not use bleach or abrasive cleaners.
- From time to time check that there are no loose screws on this unit.
- This product should not be discarded with household waste. Take to your local authority waste disposal centre.

Handy Hints

- Assemble all parts and bolts loosely during assembly, only once the product is complete should you fully tighten the bolts
- Regularly check and ensure that all bolts and fittings are tightened properly.

Note: if required the next page can be cut out and used as reference throughout the assembly. Keep this page with these instructions for future reference.

Components - Panels

For damaged or missing parts, please visit:
www.argos-support.co.uk or email: Help@ClickSpares.co.uk

Please check you have all the panels listed below

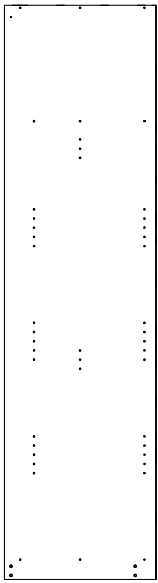

1 Left side
(199.8 x 52.9cm)
P2883

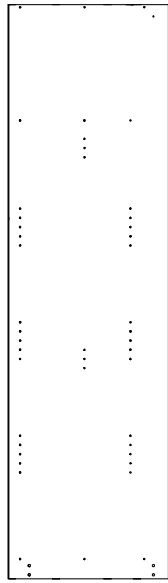

2 Right side
(199.8 x 55.8cm)
P2882

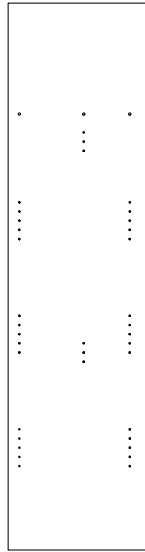

3 Upright
(190.3 x 49cm)
P2886

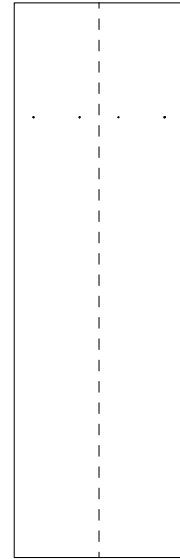

4 Foldy back x2
(193 x 59cm)
BO3429

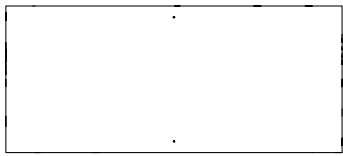

5 Top
(117 x 51cm)
P1883

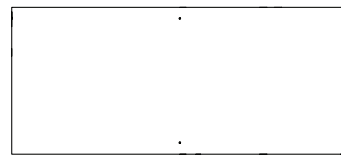

6 Bottom
(117 x 51.1cm)
P1884



7 Plinth x2
(117 x 6cm)
P7883

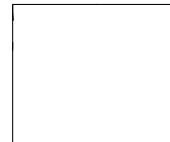

8 Shelf x2
(57.7 x 48.8cm)
P1886

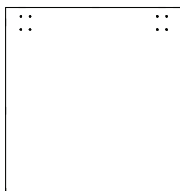

9 Segment x4
(61.3 x 65cm)
P3189

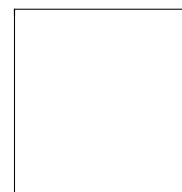

10 Segment middle x2
(61.3 x 65.1cm)
P3259











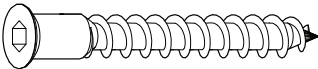
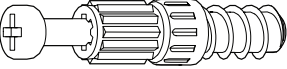
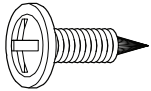

Components - Fittings

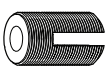
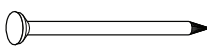
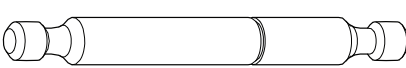
For damaged or missing parts, please visit: www.argos-support.co.uk or email: Help@ClickSpares.co.uk

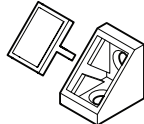
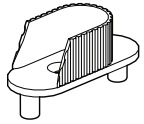
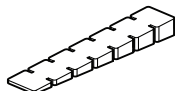
Please check you have all the fittings listed below

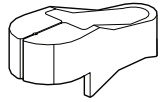
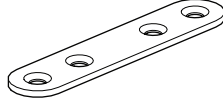
Note: The quantities below are the correct amount to complete the assembly. In some cases more fittings may be supplied than are required.

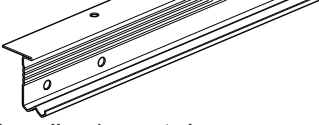
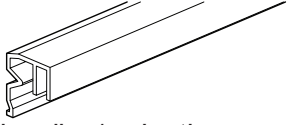
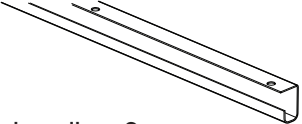
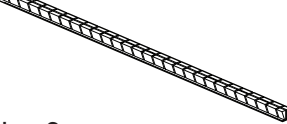
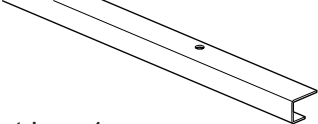
1/2

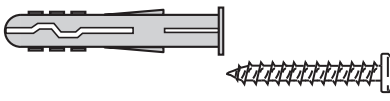
<p>A  <small>FK1005</small></p> <p>Confirmat screw x 4 (5x40mm)</p>	<p>B  <small>FK1011</small></p> <p>Locking screw x 18 (5x24mm)</p>	<p>C  <small>FK1400</small></p> <p>Screw x 49 (4x15mm)</p>
<p>D  <small>FK1309</small></p> <p>Screw x 20 (4x12.5mm)</p>	<p>E  <small>FK1082</small></p> <p>Plug, Nylon x 32 (5x9mm)</p>	<p>F  <small>FK1515</small></p> <p>Nail x 60</p>
<p>G  <small>FK1052</small></p> <p>Double locking screw x 3 (5x66.5mm)</p>	<p>H  <small>FK1411</small></p> <p>Wood dowel x 4 (8x30mm)</p>	<p>I  <small>FK1012</small></p> <p>Large locking nut x 24 (15x12mm)</p>
<p>J  <small>FK1248</small></p> <p>Corner connector, white x 2</p>	<p>K  <small>FK1217</small></p> <p>Hanger rail support, gray x 4</p>	<p>L  <small>FK1234</small></p> <p>Peg, brown x 1</p>
<p>M  <small>FK1235</small></p> <p>L-Bracket x 1</p>	<p>N  <small>FK1419</small></p> <p>Nail holder x 1</p>	<p>O  <small>FK1236</small></p> <p>Connecting plate x 4</p>
<p>P  <small>PM1823</small></p> <p>Hanger rail x 2 (569mm)</p>	<p>Q  <small>PM1613</small></p> <p>Guide rail x 1, metal (1169mm)</p>	<p>R  <small>PK1613</small></p> <p>Guide rail x 1, plastic(1169mm)</p>
<p>S  <small>PM1652B</small></p> <p>Door handle x 3 (1952mm)</p>	<p>T  <small>PM1652C</small></p> <p>Brush x 3 (1952mm)</p>	<p>U  <small>PM1652D</small></p> <p>Door trim x 1 (1952mm)</p>
<p>V  <small>FK1013</small></p> <p>Allen key x 1 (3mm)</p>	<p>W  <small>ZF99936</small></p> <p>Wall plug (6mm) and parkerscrew x 1</p>	





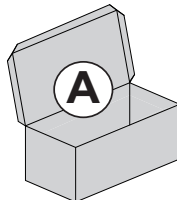

Components - Fittings

Please check you have all the fittings listed below

Note: The quantities below are the correct amount to complete the assembly. In some cases more fittings may be supplied than are required.

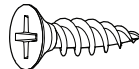
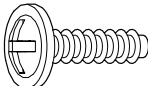
2/2

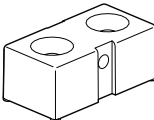

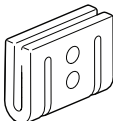
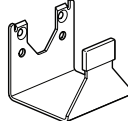
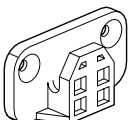
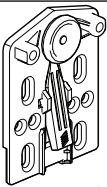
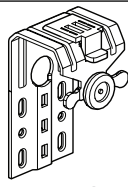
<p>AA ZF9997I</p>  <p>Screw x 2 (3.5x35mm)</p>	<p>AB ZF9997K</p>  <p>Screw x 6 (3.5x25mm)</p>	<p>AC ZF9997L</p>  <p>Screw x 33 (4x15mm)</p>
<p>AD ZF9997J</p>  <p>Screw x 2 (4x14mm)</p>	<p>AE ZF9997F</p>  <p>Spacer x 1</p>	<p>AF ZF9997E</p>  <p>Tapping block for guide rail x 2</p>
<p>AG ZF9997G</p>  <p>End stop x 2</p>	<p>AH ZF9997H</p>  <p>Stop guide rail x 2</p>	<p>AI ZF9997C</p>  <p>Front guide part x 2</p>
<p>AJ ZF9998D</p>  <p>Back guide part x 2</p>	<p>AK ZF9997B</p>  <p>Sliding door connecting plate x 2</p>	<p>AL ZF9997A</p>  <p>Sliding door connecting bracket x 2</p>

Tools required

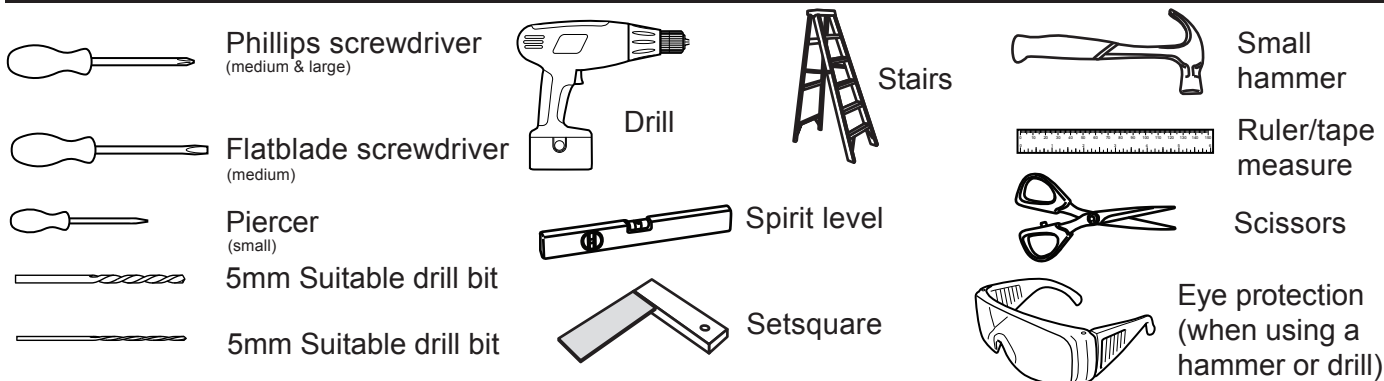

Ruler - Use this ruler to help correctly identify the screws

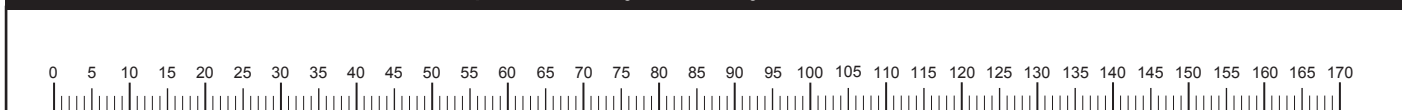

Assembly Instructions

Step 1

Cabinet assembly

a: Screw 9 locking screws **B** into the holes on back of the left side **1**.

Mount hanger rail support **K**, fasten with 1 screw **D**. Screw **D** into the board between two predrilled holes.

Mount tapping block for guide rail **AF** with two screws **AB**.

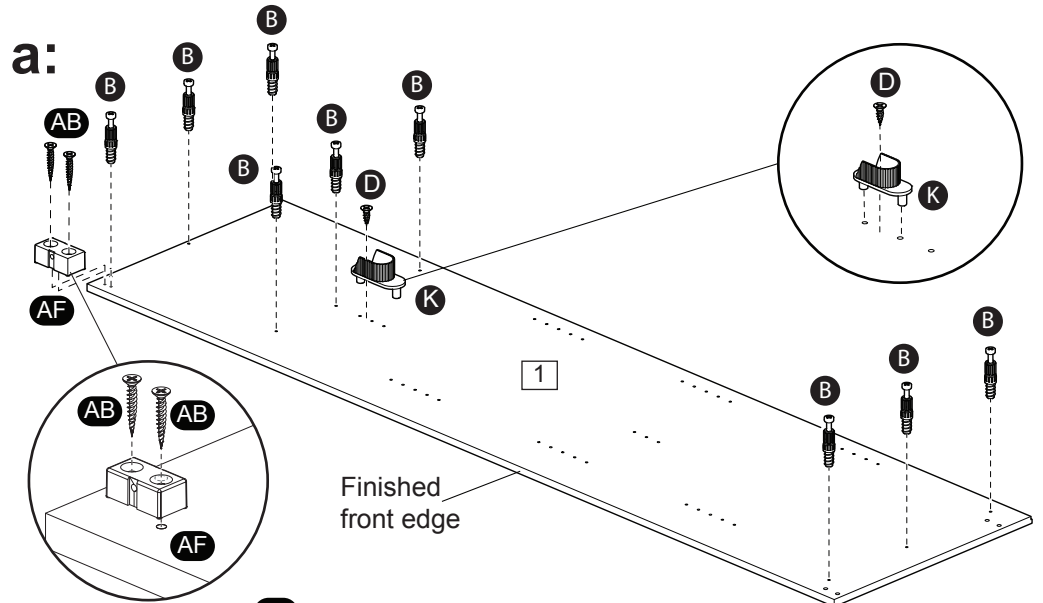

b: Screw 9 locking screws **B** into the holes on back of the right side **2**.

Mount hanger rail support **K**, fasten with 1 screw **D**. Screw **D** into the board between two predrilled holes.

Mount tapping block for guide rail **AF** with two screws **AB**.

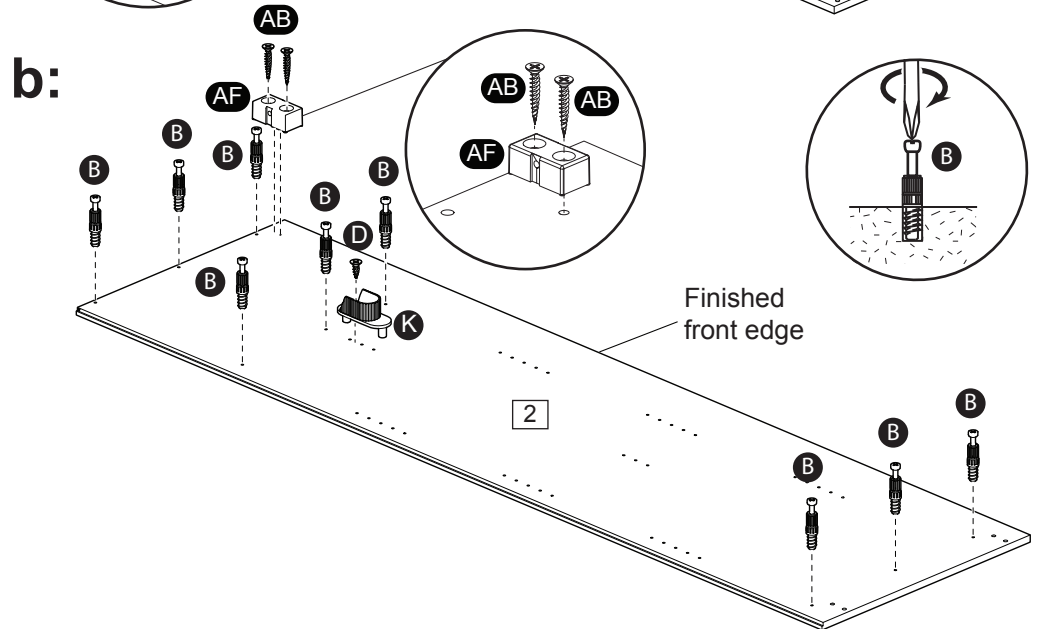

C: Mount hanger rail support **K** on the upright **3**, fasten with screw **D** 1x. Screw **D** into the board between two predrilled holes

Turn over.

Mount hanger rail support **K** on the upright **3**, fasten with screw **D** 1x. Screw **D** into the board between two predrilled holes.

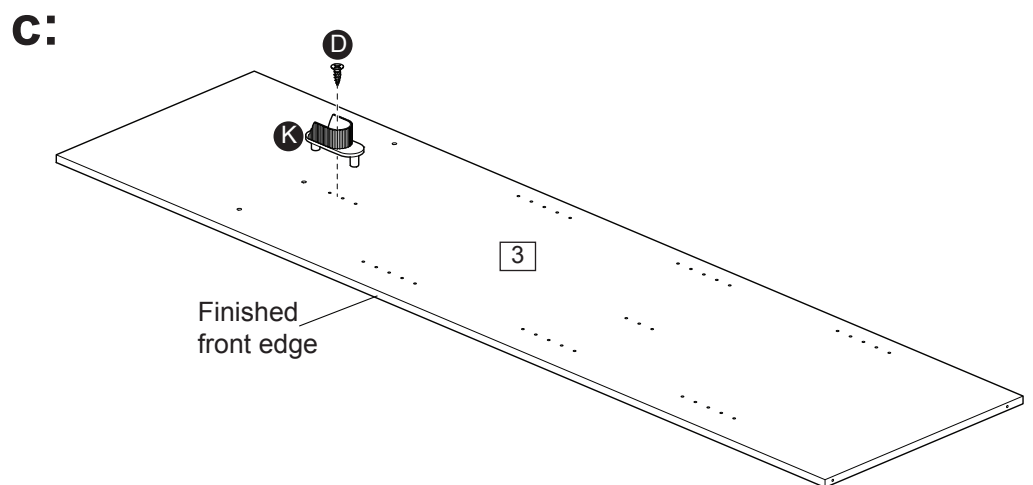

Assembly Instructions

Step 1

Cabinet assembly

d: Insert 6x small locking nuts **1** into the top **5**.

Make sure the 'arrow' on **1** is pointing towards the hole in the edge of the top **5**.

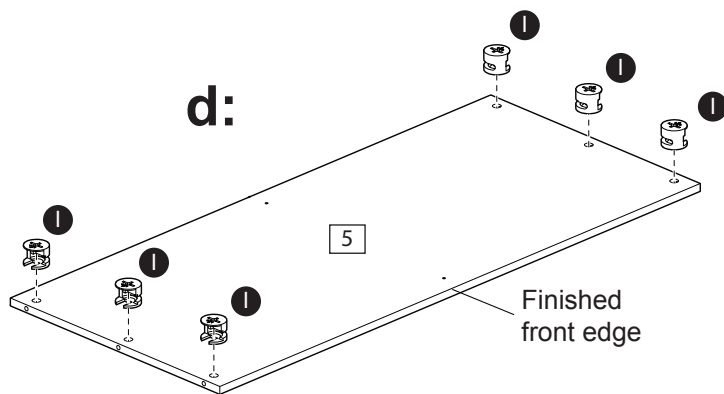

e: Insert 6x small locking nuts **1** into the bottom **6**.

Make sure the 'arrow' on **1** is pointing towards the hole in the edge of the bottom **6**.

e:

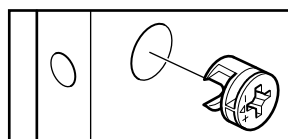
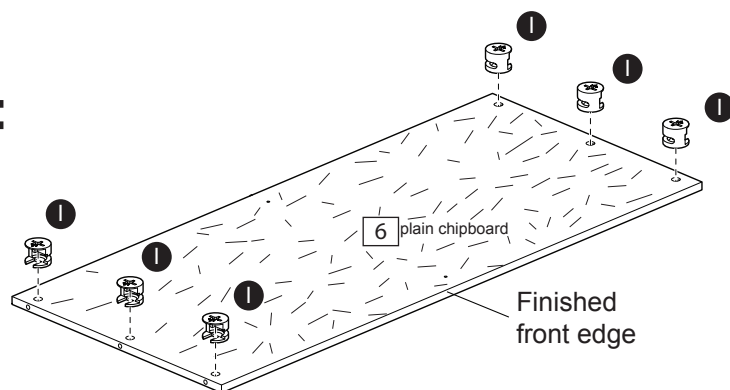

f: Insert 6x small locking nuts **1** into the shelf **6**.
2x.

Make sure the 'arrow' on **1** is pointing towards the hole in the edge of the bottom **6**.

f:

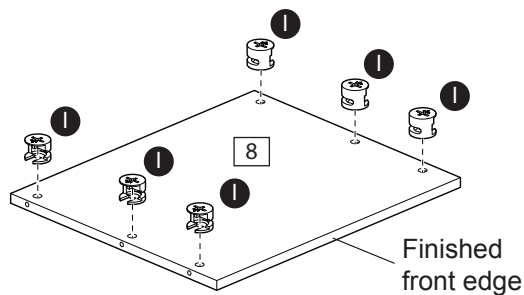

g: Insert 4x wooden dowels **H** into the plinth **7**.
2x.

g:

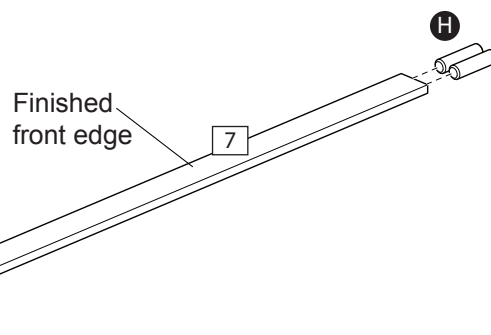

Assembly Instructions

Step 1

Cabinet assembly

h: Attach top **5** with 2x confirmat screws **A** to the upright **3**. Use allenkey **V**.

Attach bottom **6** with 2x confirmat screws **A** to the upright **3**.

i: Attach 2x the shelf **8** to the upright **3** with 3x double locking screws **G**.

Use a screwdriver to turn 6x locking nuts clockwise to lock.

j: Attach the left side **1** with 9x double locking screws **G** on the top **5**, shelf **8** and the bottom **6**.

Use a screwdriver to turn 9x locking nuts clockwise to lock.

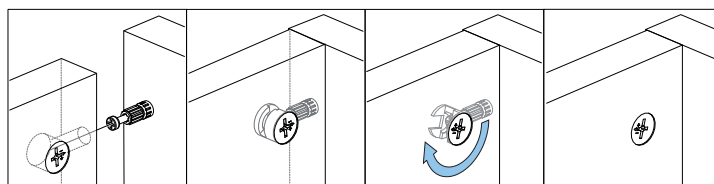
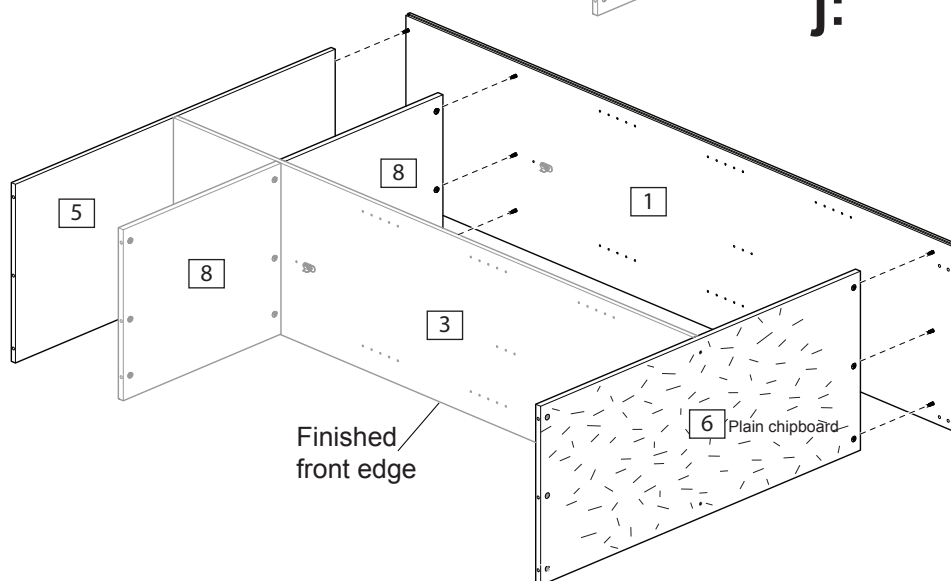
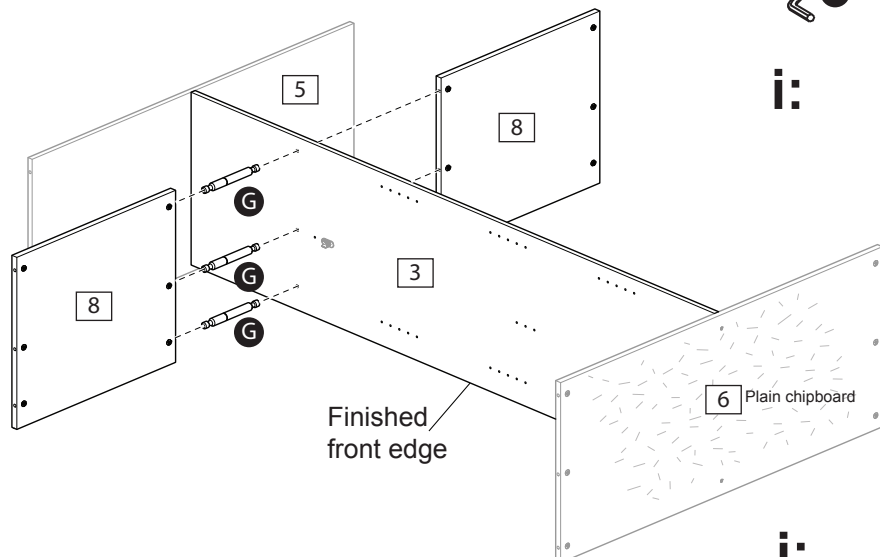
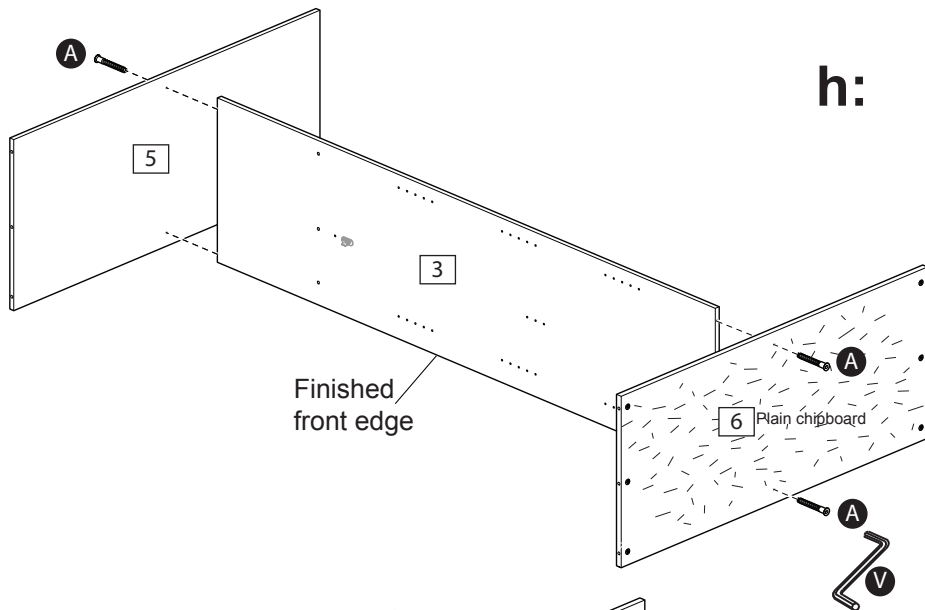

Assembly Instructions

Step 1

Cabinet assembly

k: Attach 2x the plinth [7] between the left site [1] and the right side [2].

Note: that the finished side properly placed.

Attach the right side [2] with 9x double locking screws **G** on the top [5], shelf [8] and the bottom [6].

Use a screwdriver to turn 9x locking nuts clockwise to lock.

Mount corner connector **J** with 2 screws **C** on the plinth [7] and bottom [6].

l: Attach 2x foldy back [4] to back of cabinet with the coloured surface facing the inside of the cabinet using 60x nails **F** and 22x screws **C**.

Use nail holder **N** to hold the nails **F** vertical and at correct distance as you secure the 2x foldy back [4]. Nails **F** should be spaced about 150mm apart.



Important: Cabinet **MUST** be 'square' when back is attached.

Stand up the unit!
2 people required to stand up the unit.

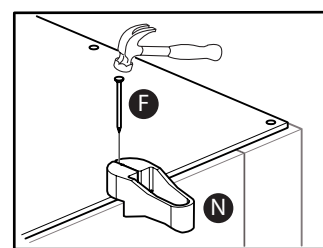
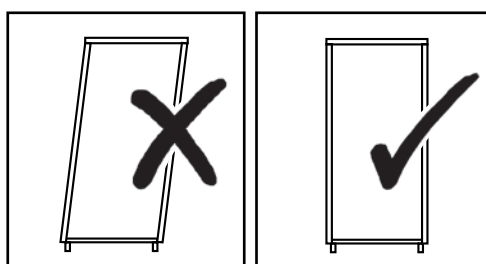
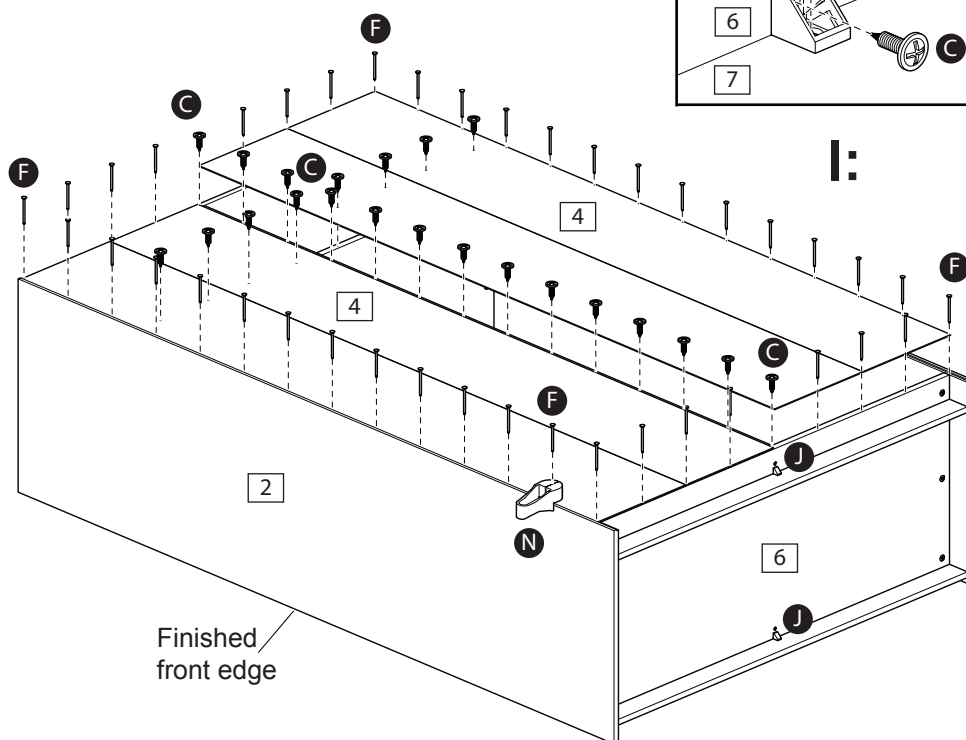
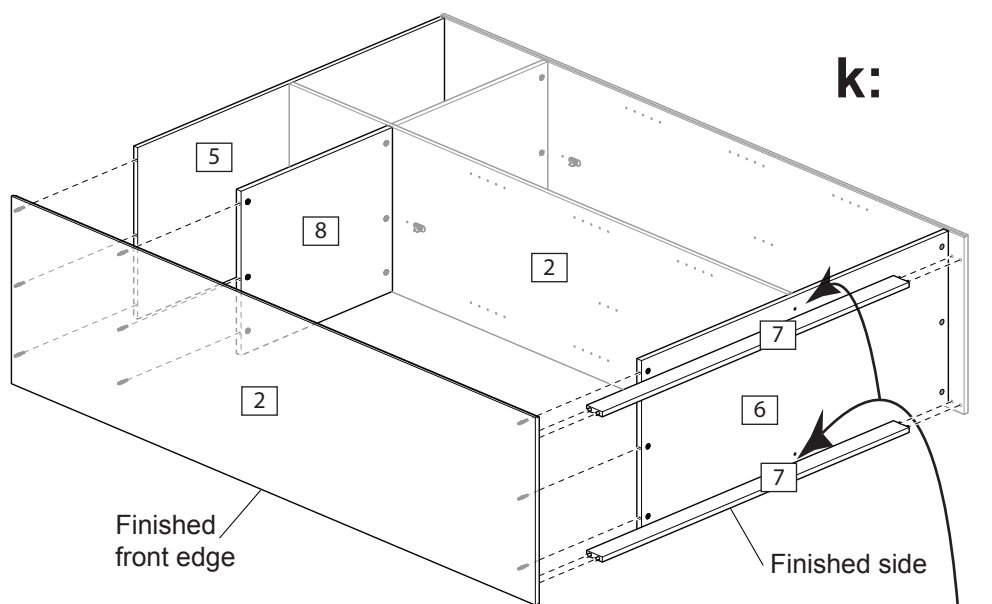

Assembly Instructions

Step 1

Cabinet assembly

m: Position L-Bracket **(M)** onto top **(5)**, by using 1x screw **(C)**.

Position metal guide rail **(Q)** onto top **(5)**, fix with 5x screws **(C)**.

Attach 2x end stop **(AG)** on the end of the guide rail **(Q)** with 2x screws **(AD)**.

Place 2x hanger rail **(P)** into hanger rail support **(K)**.

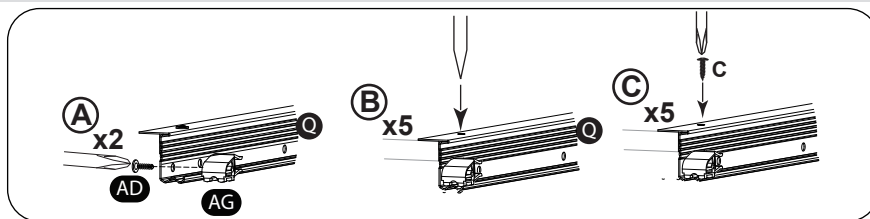

m:

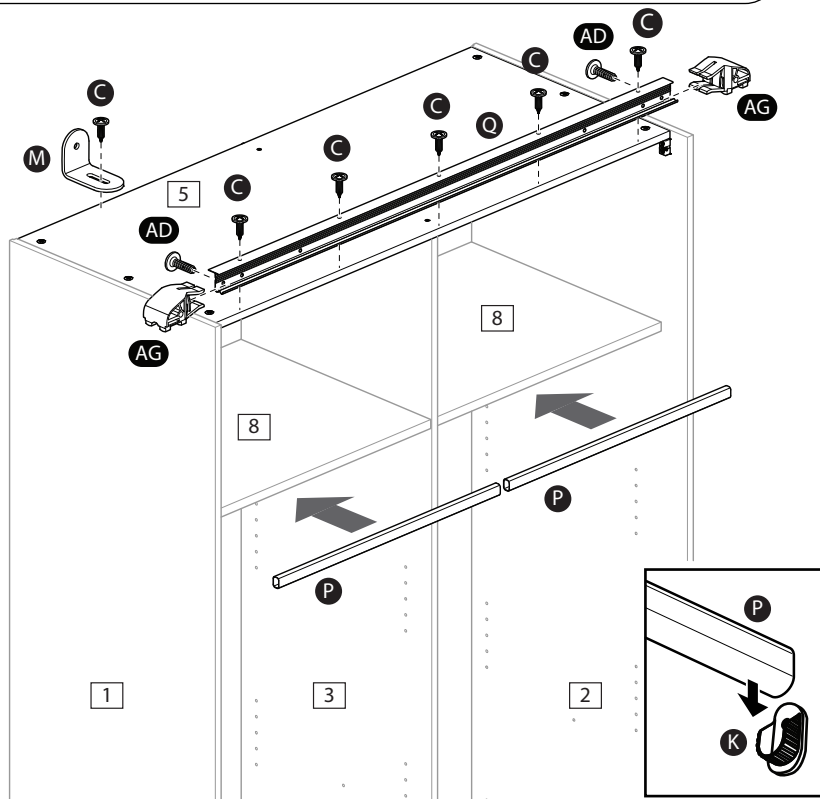

n: Position plastic guide rail **(R)** onto bottom **(6)**, fix with 5x screws **(AB)**.

Attach 2x stop guide rail **(AH)** on the end of the guide rail **(R)**, mount with 2x screws **(AA)**.

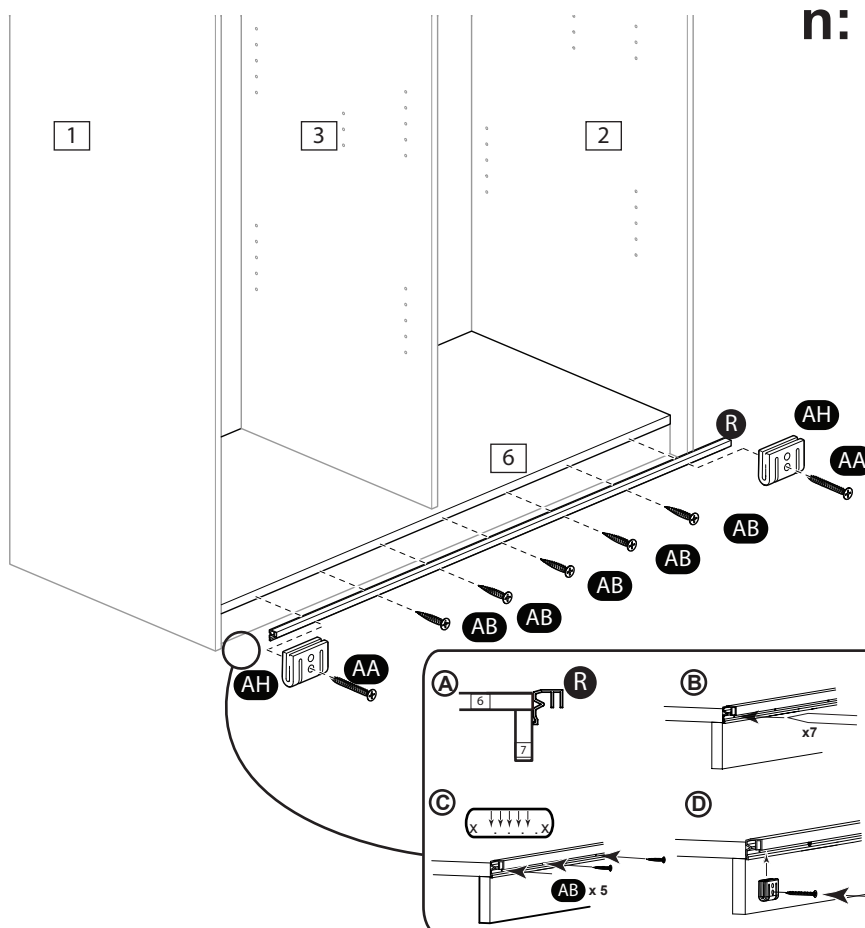

n:

Assembly Instructions

Step 2

3 Segment slide door left

a: Put 8x nylon plug **E** into the segment **9**. Use a small hammer. Repeat this step.

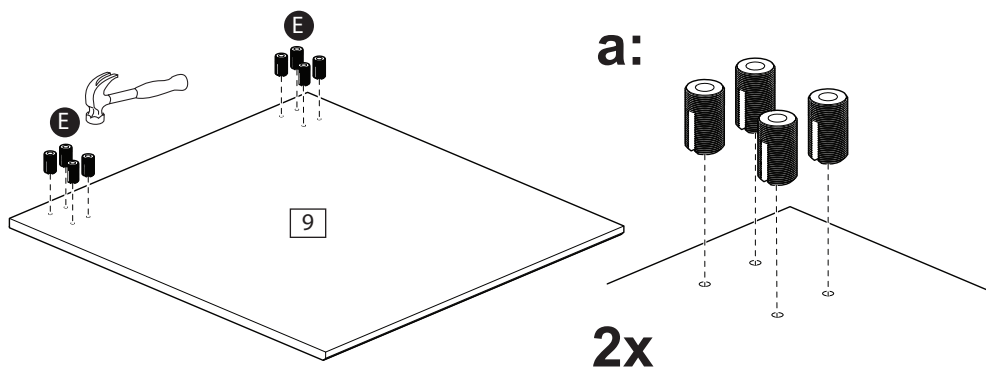

b: Mount door trim **U** with 3x screws **C** on segment **9**.

Note: there should be no gap between doorsegment **9** and door trim **U**.

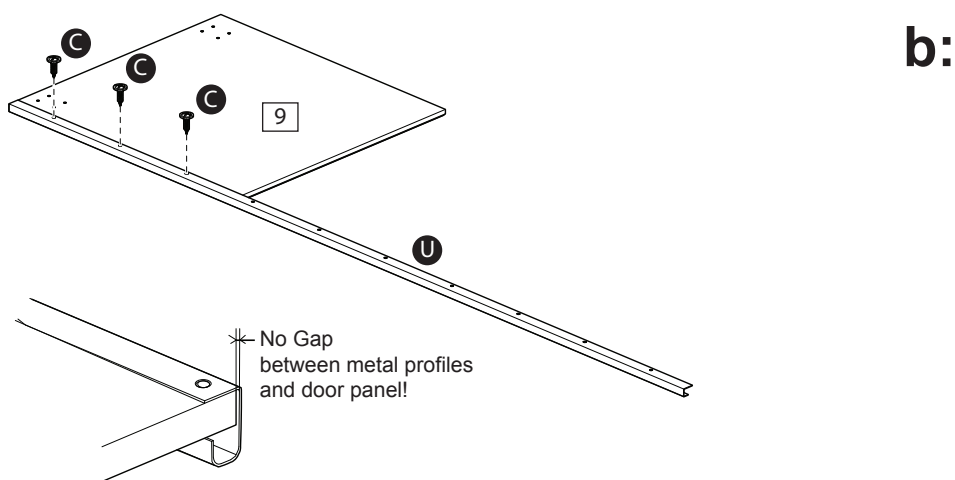

c: Mount segment middle **2** with 3x screws **C** on door trim **U**. Mount segment **9** with 4x screws **C** on door trim **U**.

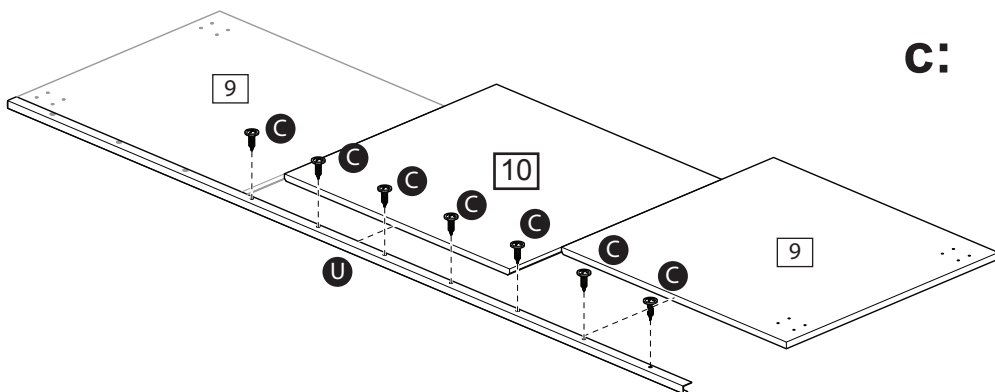

d: Mount door handle **S** on segment **9** with 4x screws **C** and on middle segment **10** with 3x screws **C**.

Note: there should be no gap between doorsegment **10** and door handle **S**.

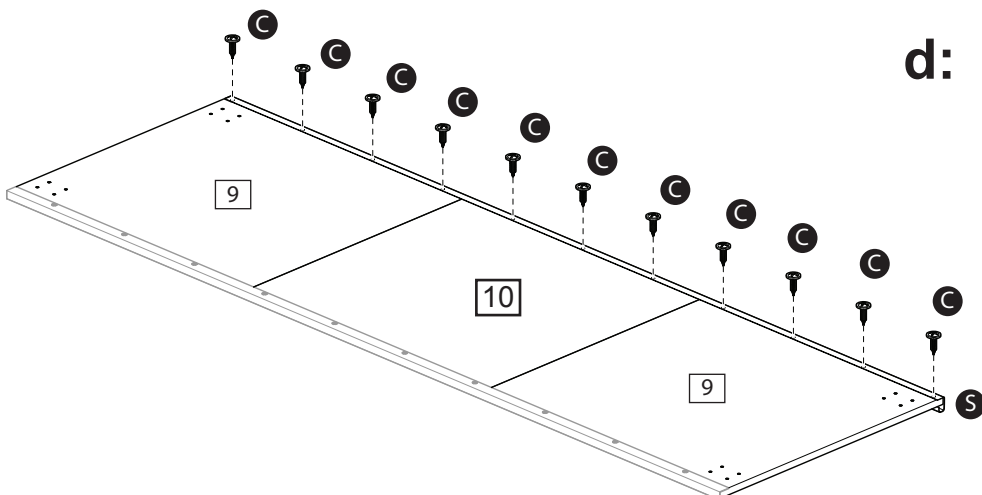

Assembly Instructions

Step 2

3 Segment slide door left

e: Mount 2x connecting plate **O**, each with 2x screws **D** on segment **9** and 2x screws **D** on middle segment **10**.

Remove protective film from door handle **S**.
Stick 1x brush **T** onto door handle **S** by partially removing the cover from adhesion as brush is applied.

f: Upside.

Mount 2x Sliding door connecting plate **AK** squarely by using the guide-marks in the plate, each with 6x screws **AC** on segment **9**.

Attach 1x spacer **AE** with 1x screw **AC** on the brush side sliding door connecting plate **AK**.

g: Underside.

Mount 2x back guide part **AJ**, each with 2x screws **AC** on segment **9**.

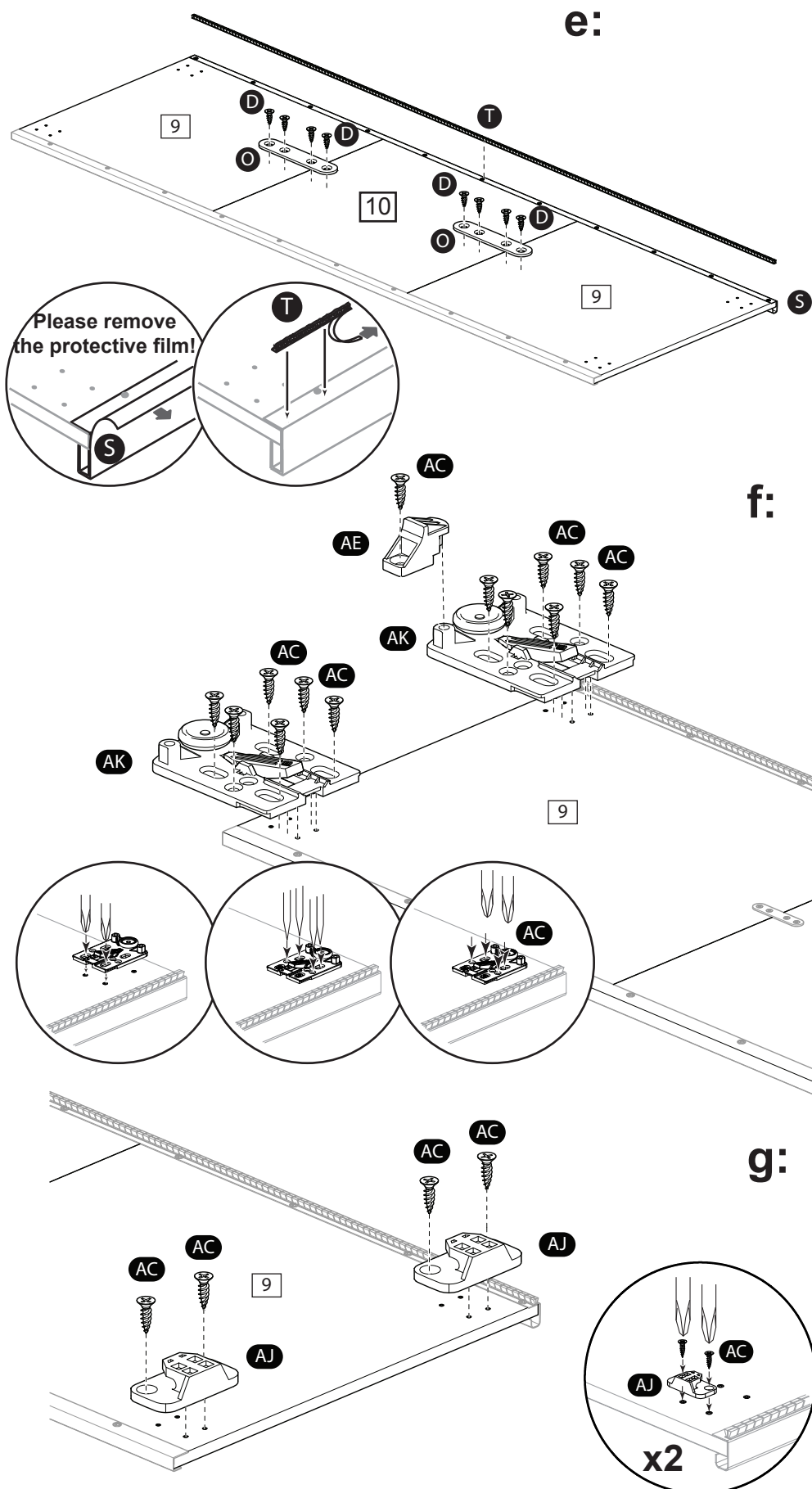

Assembly Instructions

Step 3

Place left slide door

2 People are required for step 3a and 3b.

a: Hook the 2x back guide part **AJ** into the plastic guide rail **R**.

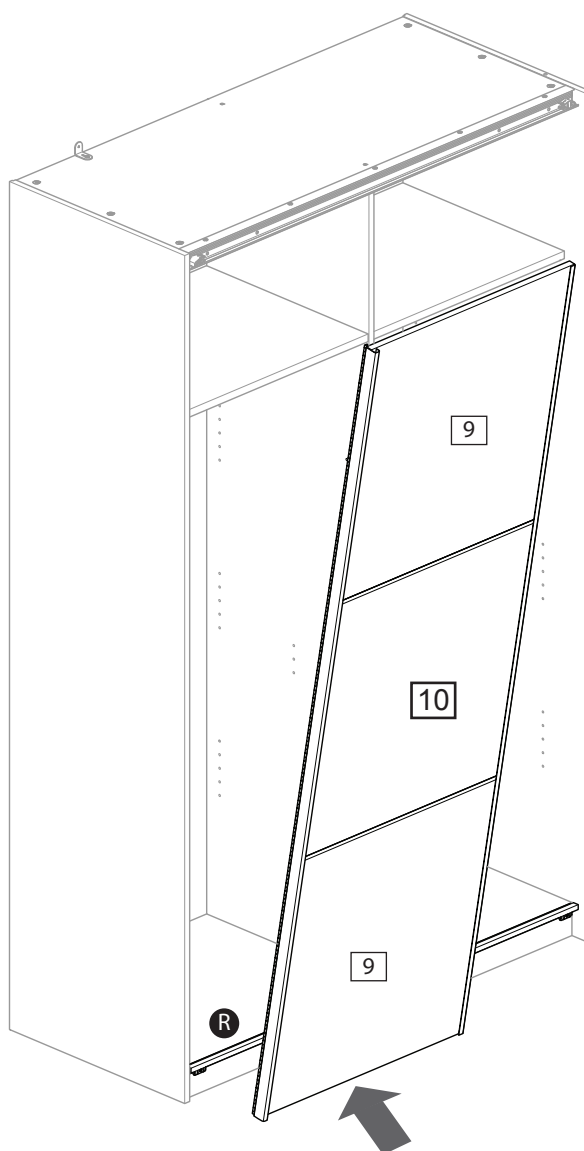

a:

a: Detail.

The hook of the back guide part **AJ** should be in the front guide of the plastic guide rail **R**.

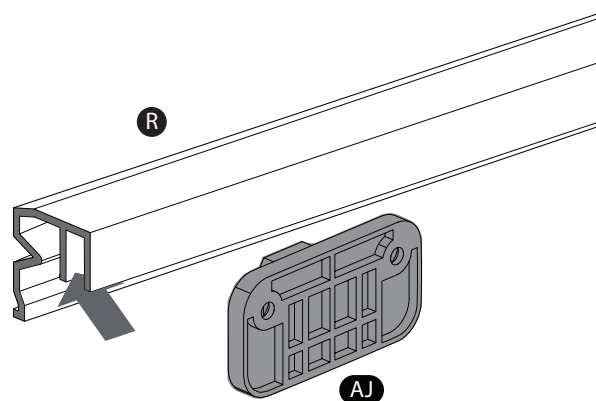
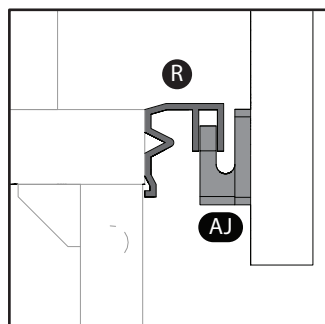

Assembly Instructions

Step 3

Place left slide door

b: Hook Sliding door connecting plate **AK** on metal guide rail **Q**.

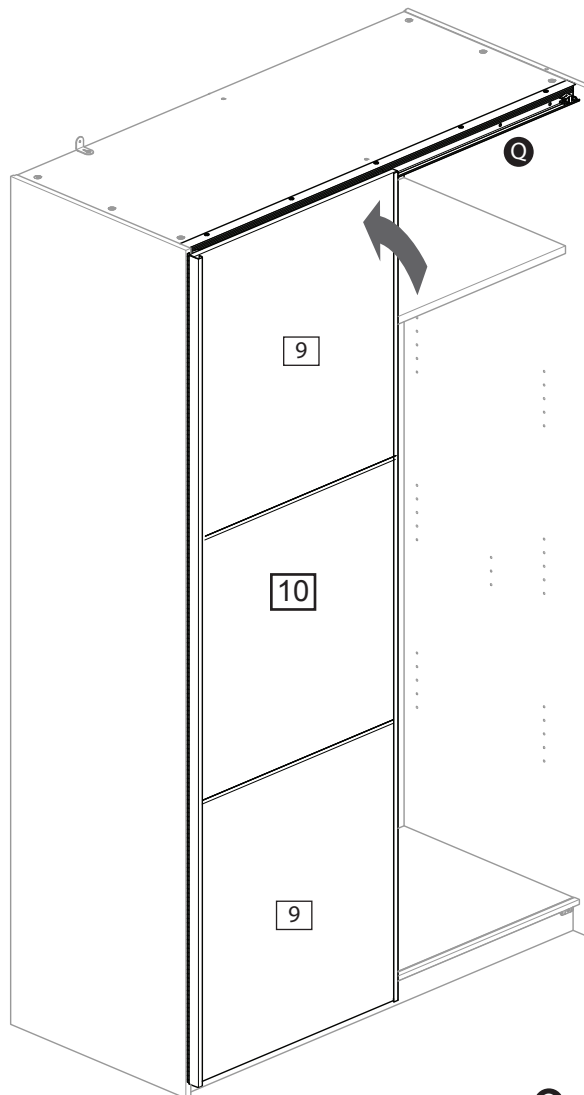

b:

b: Detail.

The wheel of the sliding door connecting plate **AK** should be in the front guide of the metal guide rail **Q**.

To lock the door, lock the Sliding door connecting plate **AK** on the guide rail **Q** with the locking pawl.

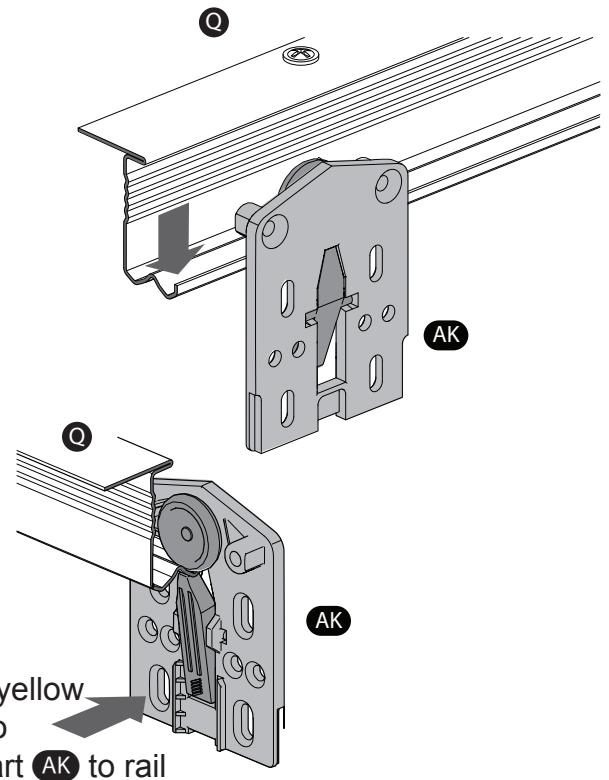
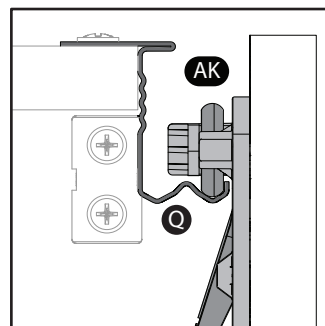

Assembly Instructions

Step 4

3 Segment slide door left

a: Put 8x nylon plug **E** into the segment **1**. Use a small hammer. Repeat this step.

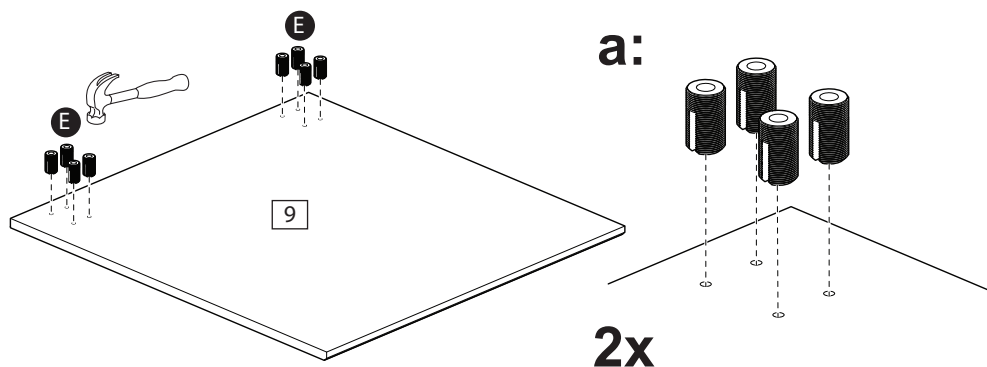

b: Mount door trim **U** with 3x screws **C** on segment **1**.

Note: there should be no gap between doorsegment **1** and door trim **U**.

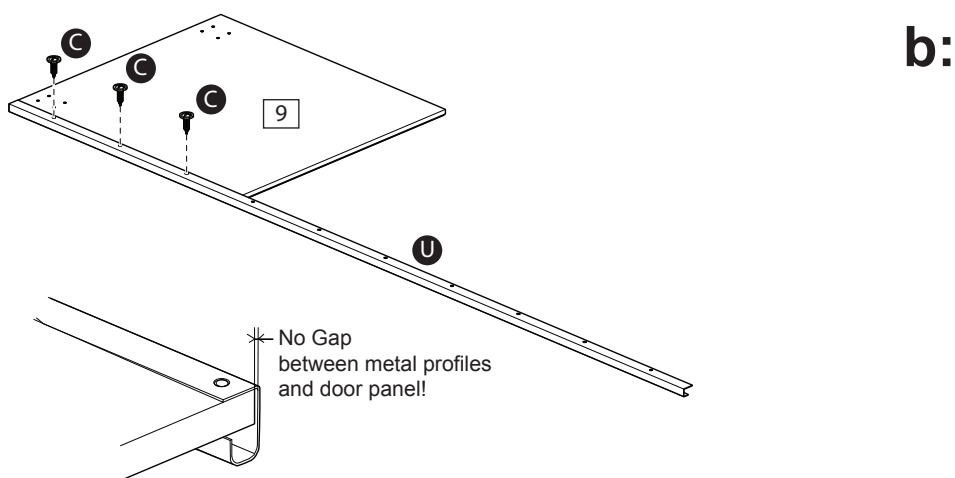

c: Mount segment middle **2** with 3x screws **C** on door trim **U**. Mount segment **1** with 4x screws **C** on door trim **U**.

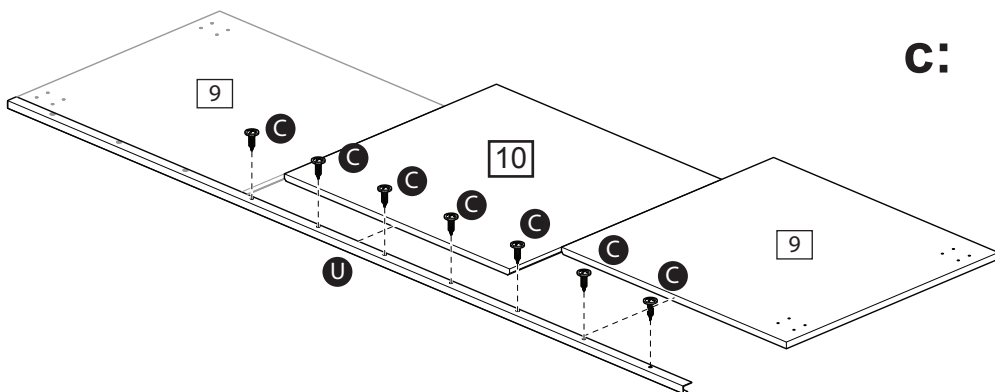

d: Mount door handle **S** on segment **1** with 4x screws **C** and on middle segment **2** with 3x screws **C**.

Note: there should be no gap between doorsegment **1** and door handle **S**.

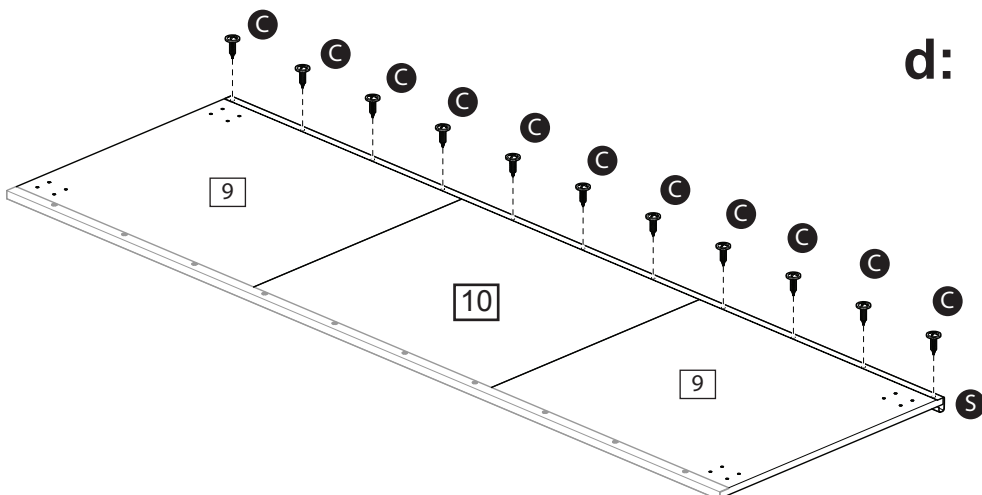

Assembly Instructions

Step 4

3 Segment slide door right

e: Mount 2x connecting plate **O**, each with 2x screws **D** on segment **9** and 2x screws **D** on middle segment **10**.

Remove protective film from door handle **S**.
Stick 2x brush **T** onto 2x door handle **S** by partially remove the cover from adhease as brush is applied.

f: Upside.
Mount 2x sliding door connecting bracket **AL** squarely by using the guidemarks in the plate, each with 6x screws **AC** on segment **9**.

g: Underside.
Mount 2x front guide part **AI**, each with 2x screws **AC** on segment **9**.

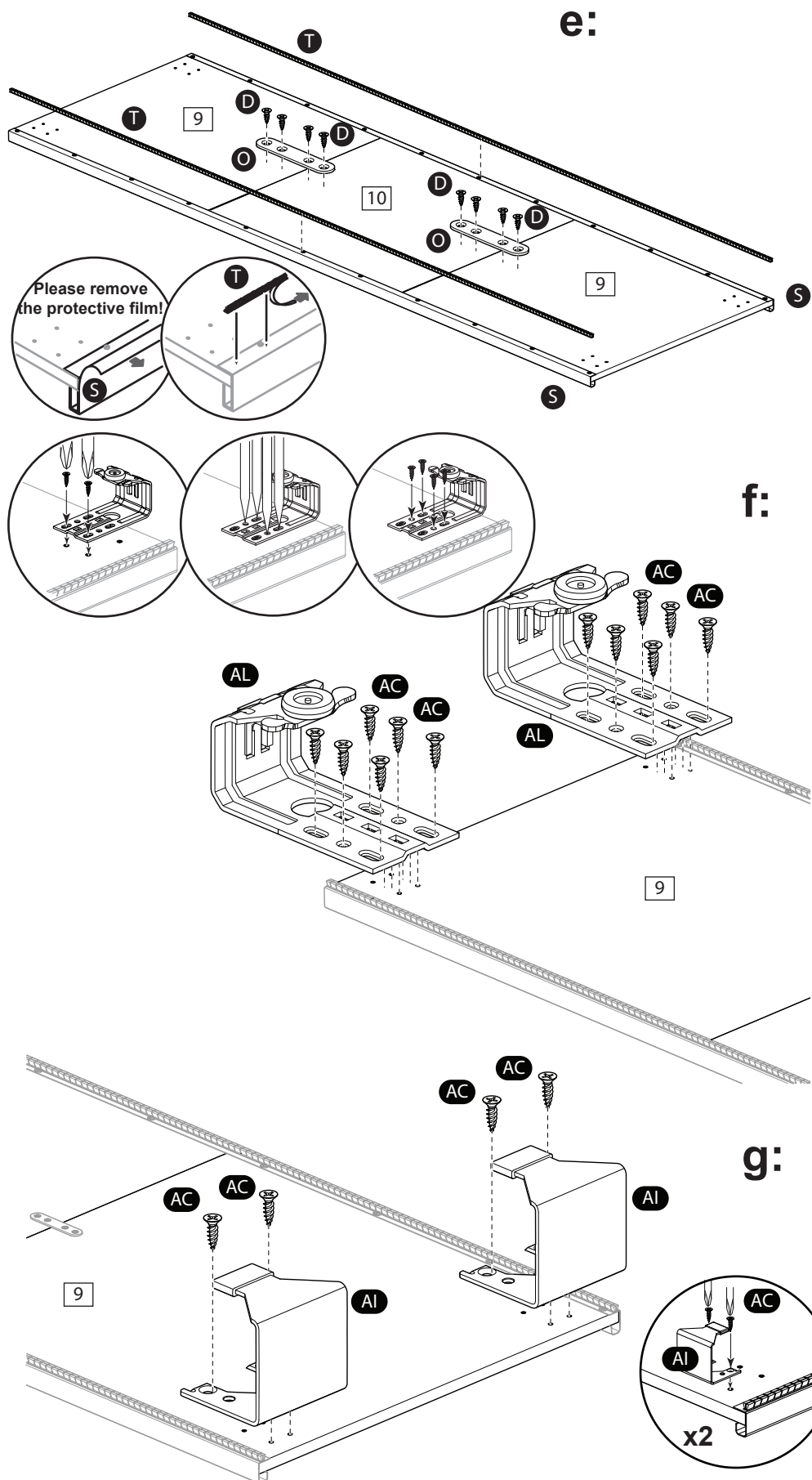

Assembly Instructions

Step 5

Place right slide door

a: Hook the 2x front guide part **AI** into the plastic guide rail **R**.

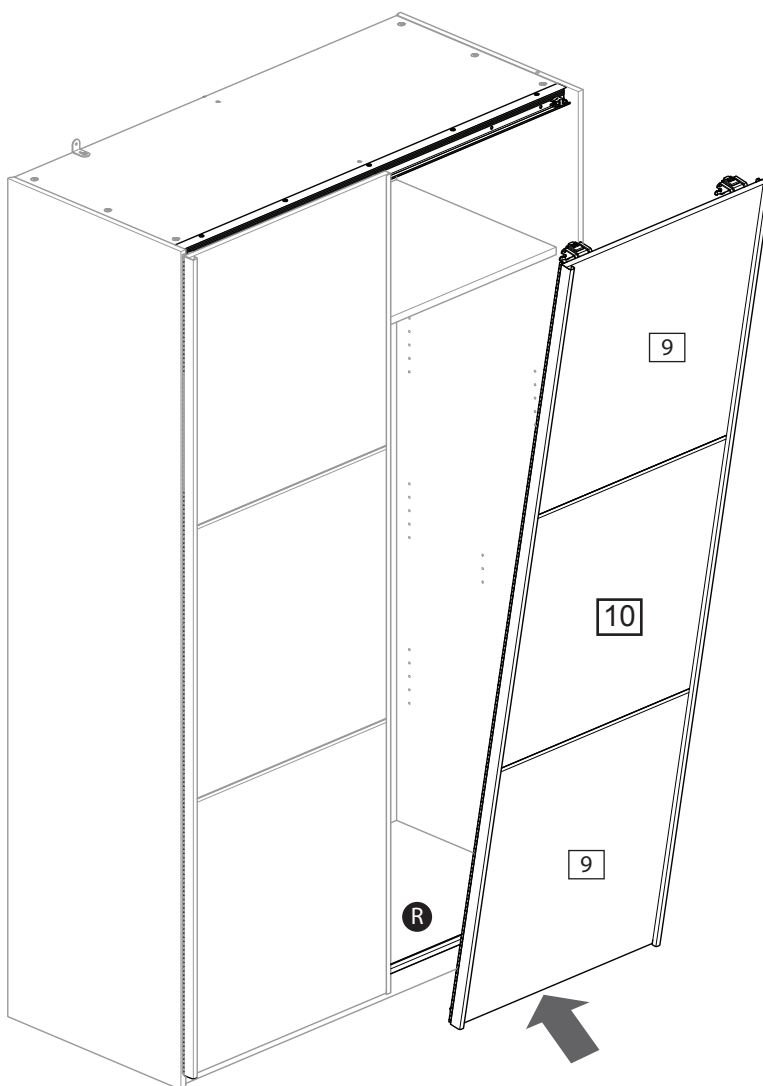

a: Detail.
The hook of the front guide part **AI** should be in the rear guide of the plastic guide rail **R**.

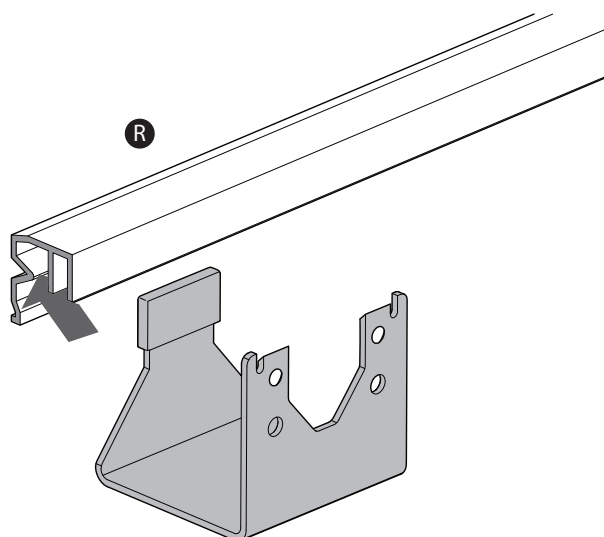
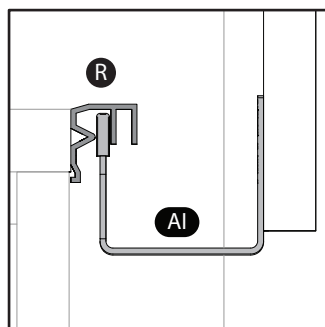

Assembly Instructions

Step 5

Place right slide door

b: Hook the sliding door connecting bracket **AL** on metal guide rail **Q**.

a:

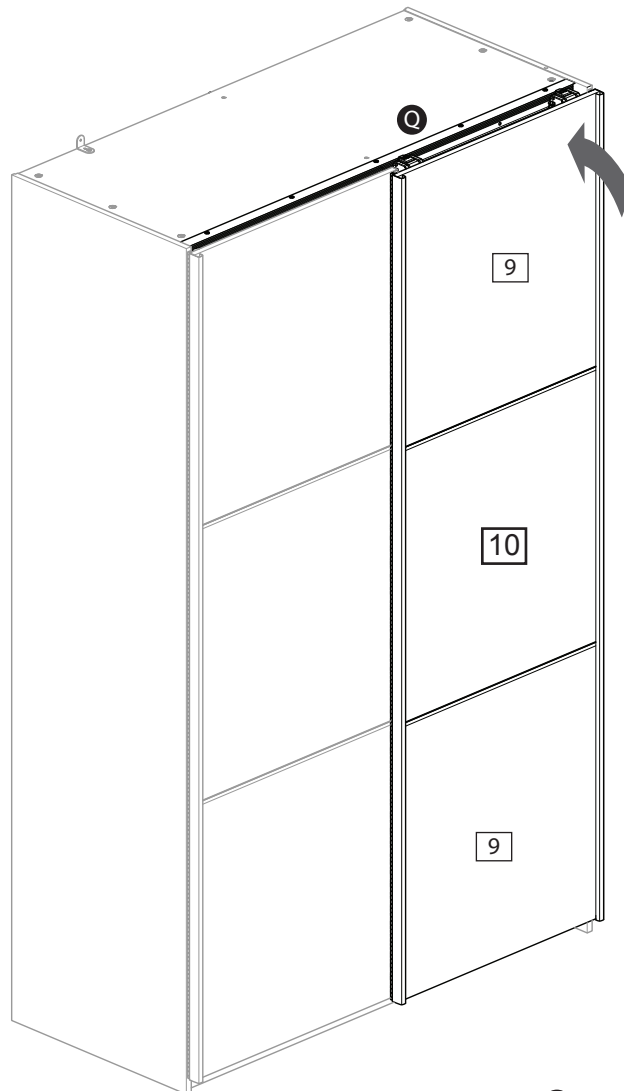

b: Detail.

The wheel of the sliding door connecting bracket **AL** should be in the rear guide of the metal guide rail **Q**.

To lock the door, lock the sliding door connecting bracket **AL** on the guide rail **Q** with the locking pawl.

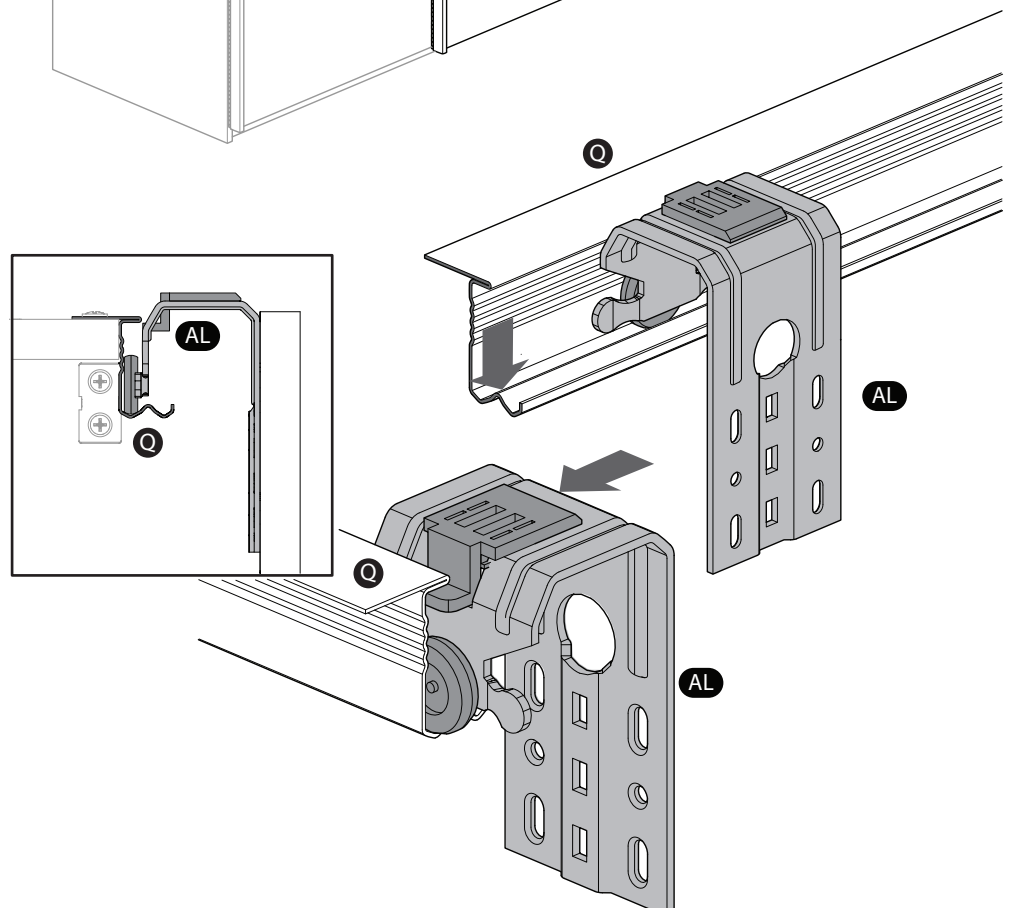

Assembly Instructions

Step 6

Place cabinet

a: Use to 1x wall plug **W** to mount L-Bracket **M** on the wall, please see last page for more information.

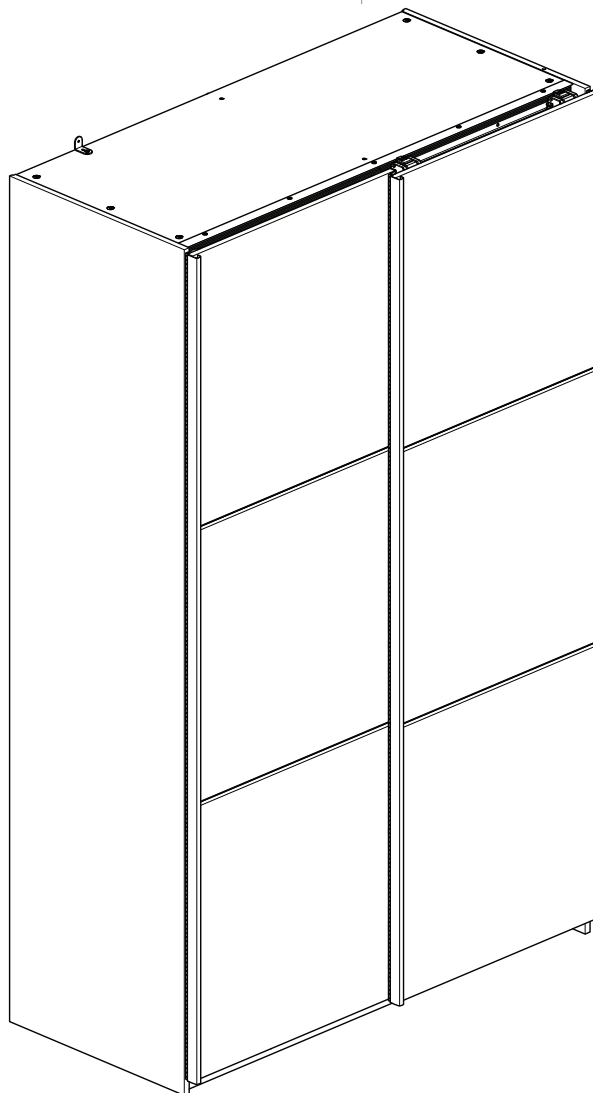
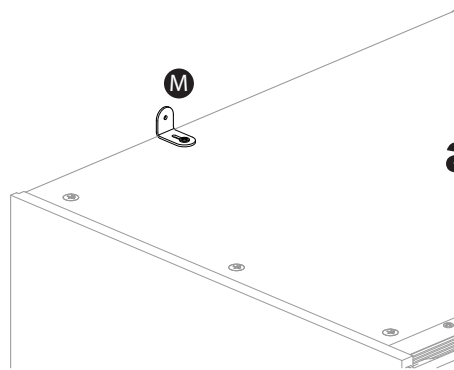
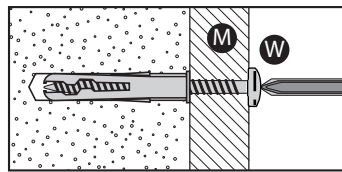

b: Before adjusting the doors, use a spirit level to check if the base of this unit is level front-to-back and side-to-side in the three positions shown.

Use pegs **L** to square your unit. Knock peg **L** in, as far as you require, under the ends of the unit and then snap off flush with the panel.

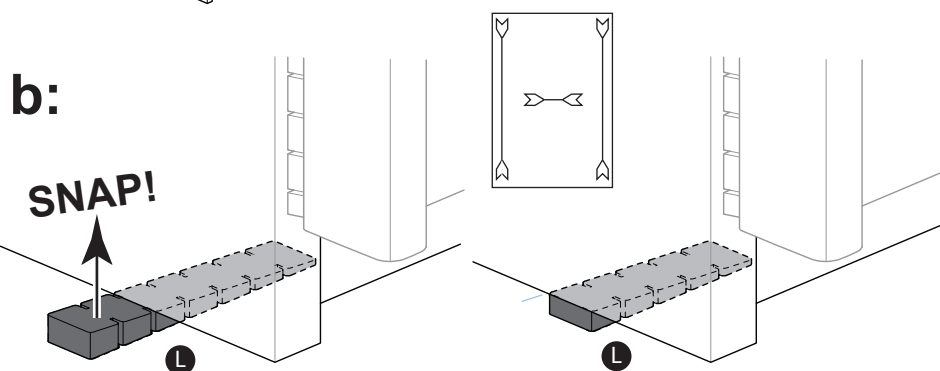

A Guide to - Wall Mounting & Fixings

Important note:

If plastic wall plugs are supplied with your product:



- these are only suitable for use in masonry walls.

If you are in any doubt about the correct wall plugs for your wall, seek professional advice.

Failure of the product due to using incorrect fixings is the responsibility of the installer.



Important: When drilling into walls always check that there are no hidden wires or pipes etc.

Make sure that the screws and wall plugs being used are suitable for supporting your unit. Consult a qualified tradesperson if you are unsure.

Hints:

- 1: General rule:**  Always use a larger screw and wall plug if you are not sure.
- 2:** Ensure you use the recommended drill bit to match the wall plug and hole size.
- 3:** Ensure you drill the hole horizontally, do not force the drill or enlarge the hole.
- 4:** Take extra care when drilling high walls, ceilings and ceramic tiles. Ensure wall plugs are inserted beyond the thickness of the ceramic tiles to avoid the tiles splitting or cracking.
- 5:** Ensure wall plugs are well fitted and are a tight fit in the drilled hole.

Types of walls

You can use one of the following types of wall plug if your walls are made of brick, breeze block, concrete, stone or wood.

No.1 "General Purpose" wall plug

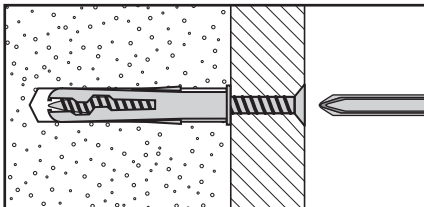

Generally aerated blocks should not be used to support heavy loads, use a specialist fitting in this case. For light loads, general purpose wall plugs can be used.

No.2 "Plasterboard" wall plug

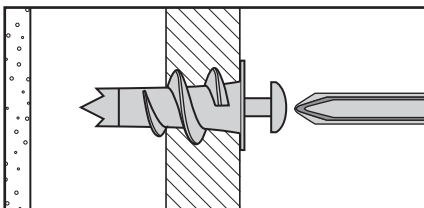

For use when attaching light loads on to plasterboard partitions.

No.3 "Cavity Fixing" wall plug

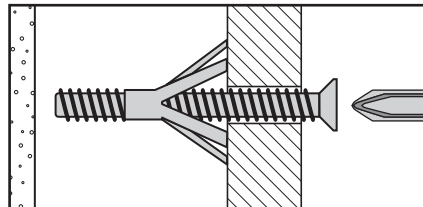

For use with plasterboard partitions or hollow wooden doors.

No.4 "Cavity Fixing-Heavy Duty" wall plug

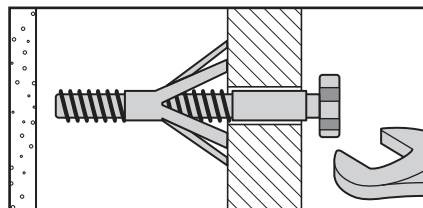

For use when fitting or supporting heavy loads such as shelving, wall cabinets and coat racks.

No.5 "Hammer Fixing" wall plug

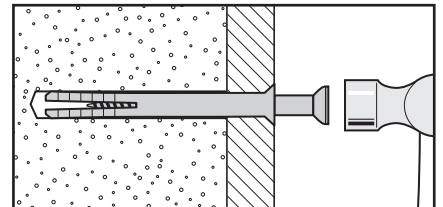

For use with walls stuck with plasterboard. The hammer fixing allows it to be fixed to the wall rather than the plasterboard. Always check the fixing is secure to the retaining wall.

No.6 "Shield Anchor" wall plug Heavy loads

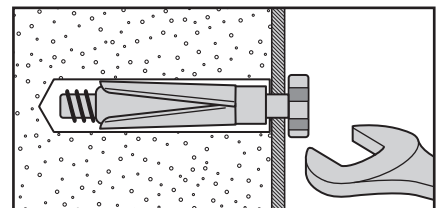

For use with heavier loads such as TV & HiFi speakers and satellite dishes etc.



Care & Maintenance

Safety: Always check the fitting and location to ensure your safety in and around the home.

Fitting: From time to time check the fitting to ensure the wall plugs or screws do not become loose.

Bergen 2 drawer bedside chest

Assembly Instructions Please keep for future reference

241/6757

226/4088

248/5881



Dimensions

Width - 45.5cm

Depth - 38.1cm

Height - 43.9cm

241/6757 OAK
226/4088 WHT
248/5881 WAL

Tip : To prevent damage, we recommend that you build your unit on the carton(s) it was packed in.

Important – Please read these instructions fully before starting assembly

If you need help or have damaged or missing parts, please visit: www.argos-support.co.uk or email: Help@ClickSpares.co.uk (quoting your original order number)

Alternatively, call the Spares Helpline on: **0370 112 1928**

For any other queries please contact the Customer Helpline on: **0345 640 2020**



Safety and Care Advice

Important – Please read these instructions fully before starting assembly

- Check you have all the components and tools listed on pages 2 and 3.
- Remove all fittings from the plastic bags and separate them into their groups.
- Keep children and animals away from the work area, small parts could choke if swallowed.
- Make sure you have enough space to layout the parts before starting.

- Do not stand or put weight on the product, this could cause damage.
- Assemble the item as close to its final position (in the same room) as possible.
- Assemble on a soft level surface to avoid damaging the unit or your floor.
- Parts of the assembly will be easier with 2 people.



• To reduce the likelihood of damaging your product please ensure that your power drill is set on a low torque setting.

- Dispose of all packaging carefully and responsibly.

Glue safety - Take care when using glue, please follow the advice below

Skin contact: Remove contamination by washing with soap and water. This procedure should also be followed prior to eating and drinking.

Eye contact: Rinse immediately with clean water for 15 minutes and seek medical advice.

If swallowed: Seek medical advice immediately.

Care and maintenance

• Only clean using a damp cloth and mild detergent, do not use bleach or abrasive cleaners.

• From time to time check that there are no loose screws on this unit.

• This product should not be discarded with household waste. Take to your local authority waste disposal centre.

Handy Hints

• Assemble all parts and bolts loosely during assembly, only once the product is complete should you fully tighten the bolts

• Regularly check and ensure that all bolts and fittings are tightened properly.

Note: if required the next page can be cut out and used as reference throughout the assembly. Keep this page with these instructions for future reference.

Components - Panels

For damaged or missing parts, please visit:
www.argos-support.co.uk or email: Help@ClickSpares.co.uk

Please check you have all the panels listed below

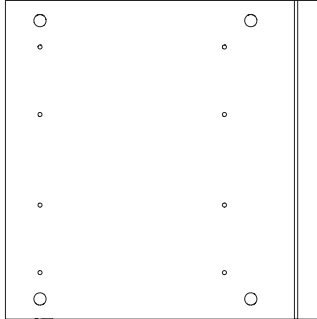

1 Left & Right Side x 2
(38.7 x 38cm)
P2028

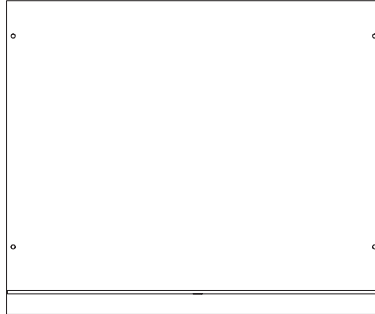

2 Top
(45.5 x 38.1cm)
P1985

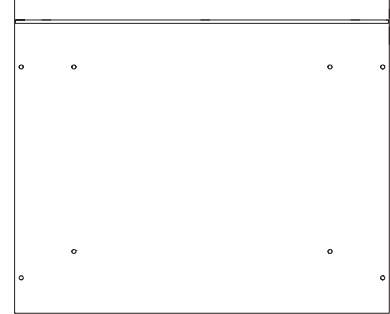

3 Bottom
(45.5 x 38.1cm)
P1986

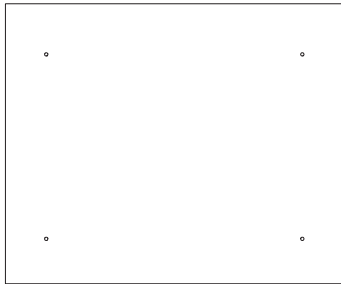

4 Foot
(41 x 34cm)
P1987

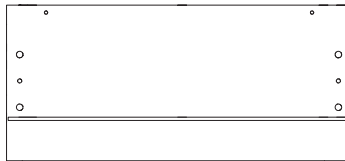

5 Drawerfront x 2
(41.9 x 18.8cm)
FA4233 / P4233

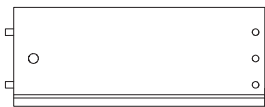

6 Left Drawer Side x 2
(30.5 x 12cm)
LA163109

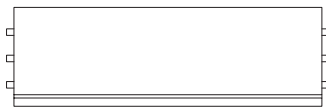

7 Drawer Back x 2
(37.4 x 12cm)
LA162909

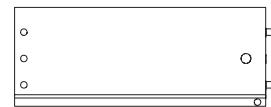

8 Right Drawer Side x 2
(30.5 x 12cm)
LA163209



9 Foldy Back
(43.5 x 39.8cm)
BO253809



10 Drawer Base x 2
(38.6 x 29.9cm)
BO251209











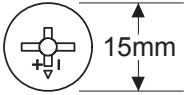
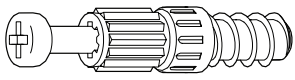

Components - Fittings

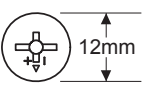
For damaged or missing parts, please visit: www.argos-support.co.uk or email: Help@ClickSpares.co.uk

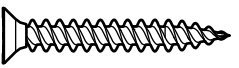
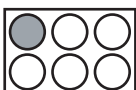
Please check you have all the fittings listed below

Note: The quantities below are the correct amount to complete the assembly. In some cases more fittings may be supplied than are required.

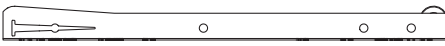
1/1

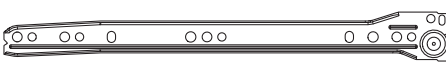
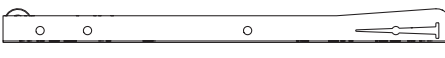
<p>A   15mm</p> <p>Large locking nut x 8 (15x12mm)</p> <p>FK1012</p>	<p>B </p> <p>Locking screw x 12 (5x24mm)</p> <p>FK1011</p>	<p>C   12mm</p> <p>Small locking nut x 4 (12x10mm)</p> <p>FK1010</p>
<p>D </p> <p>10mm Fixing screw drawer x 8</p> <p>FK1301</p>	<p>E </p> <p>12,5mm Pozi screw x 34</p> <p>FK1309</p>	<p>F </p> <p>30mm Chipboard screw x 4</p> <p>FK1322</p>
<p>G </p> <p>Felt selfadhesive x 6</p> <p>FK1416</p>	<p>H </p> <p>Glue x 1</p> <p>FA1510</p>	<p>I </p> <p>Drawerbase support x 16</p> <p>FK1250</p>
<p>J </p> <p>Runner left part A x 2</p> <p>PM1516LA</p>	<p>K </p> <p>Runner left part B x 2</p> <p>PM1516LB</p>	<p>L </p> <p>Drawer handle x 2</p> <p>GR1978</p>
<p>M </p> <p>Runner right part A x 2</p> <p>PM1516RA</p>	<p>N </p> <p>Runner right part B x 2</p> <p>PM1516RB</p>	

Tools required

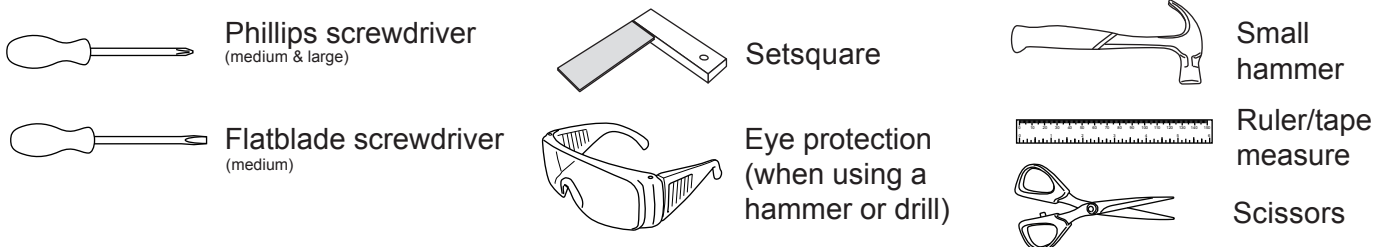

Ruler - Use this ruler to help correctly identify the screws

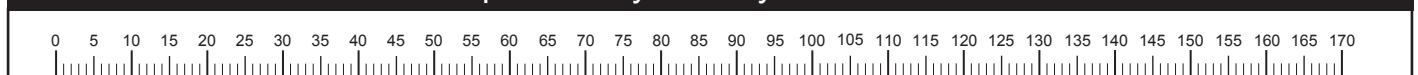

The screws length is measured from the head to the point (30mm screw shown).

Assembly Instructions

Step 1

a: Prepare the drawer fronts

Screw 2 locking screw **B** into the holes shown on the back of each drawer front **5**.

Note: Insert locking screw **B** as far as shown. **Do not over tighten.**

a:

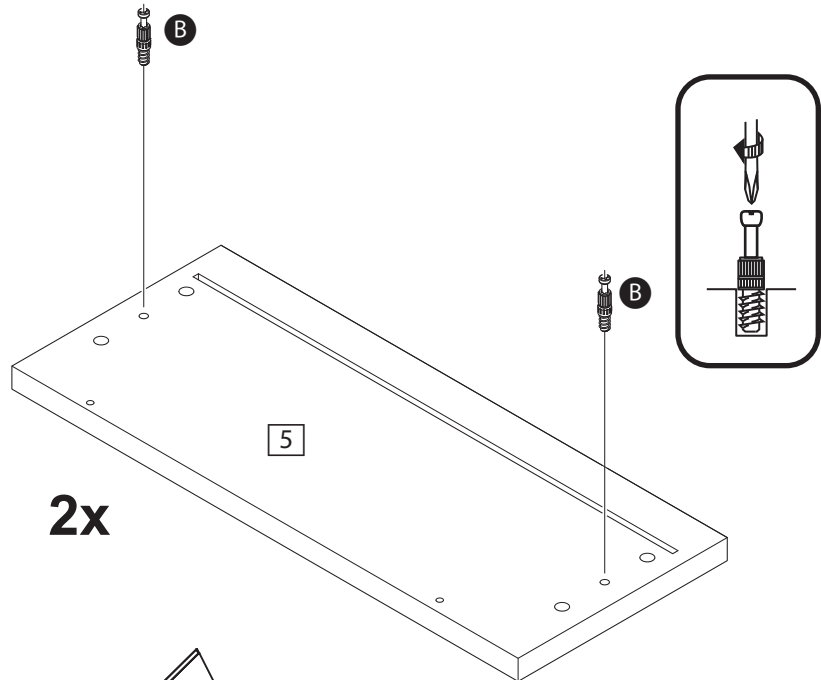

b: Prepare the drawer sides

Insert a small locking nut **C** into the hole on left drawer side **6** and right drawerside **8**. Make sure the 'arrow' on **C** is pointing towards the hole in the edge of **6** and **8**.

Put drop of glue **J** in the 6 holes of drawersides **6** and **8** before sliding them onto the dowels of drawerback **7**. Slide drawerbase **10** in the grooves of the drawer-unit.

b:

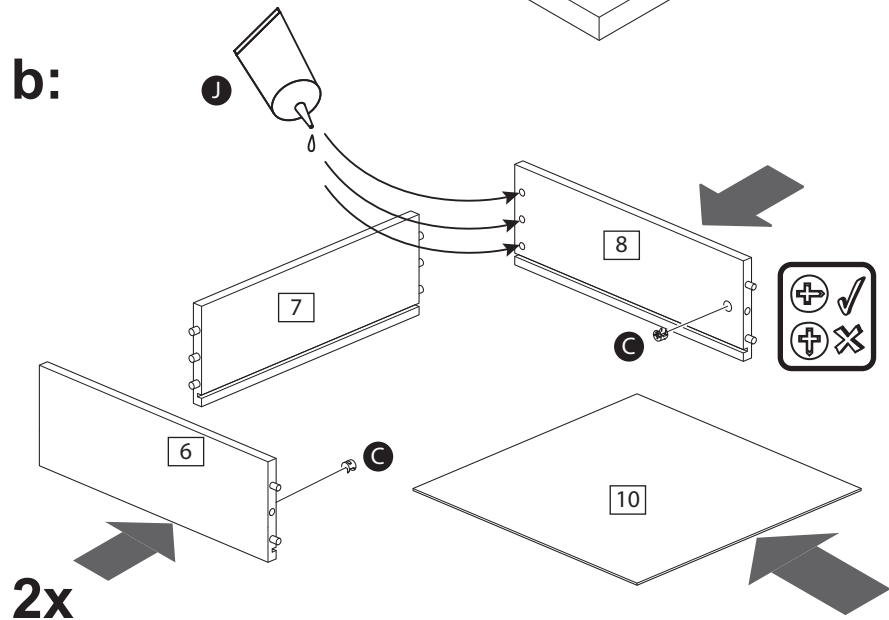

c: Turn the drawer wrap assembly over and push onto the drawer front **5**. Use a phillips or flatblade screwdriver, that is a good fit, to turn 24mm locking nut **C** as far as it will go - more than 1/2 turn.

c:

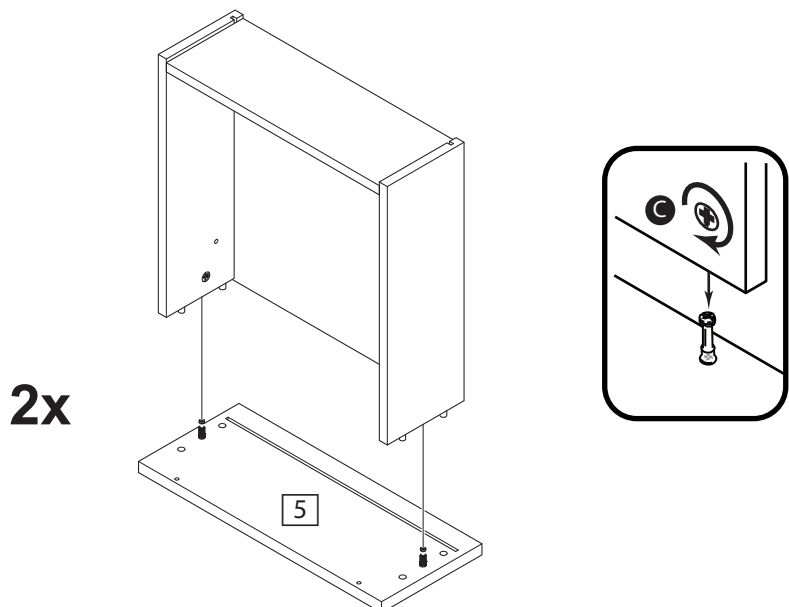

Assembly Instructions

Step 1 continued

finishing the drawers

d: Turn over drawer and slide drawerbase supports **l** in corner as shown and fix them, using the attached screws.

d:

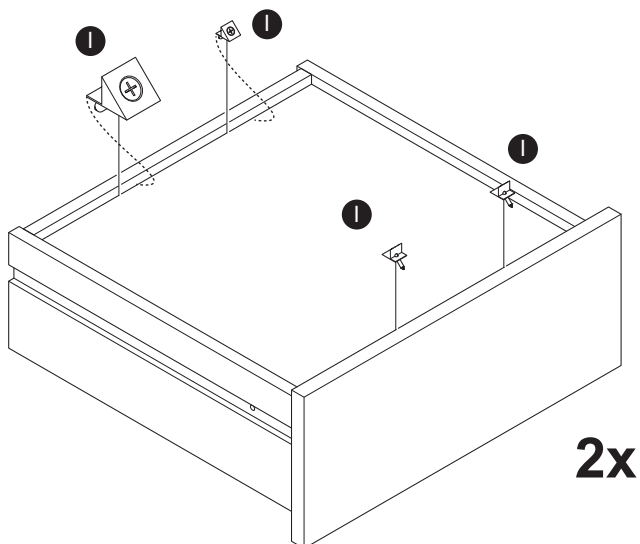

Step 2

Attaching runners

a: Fix runner left and right side A **J** and **M** on left & right side **1** as shown using 10mm fixing screw drawer **D** and 12,5mm pozi screw **E**.

a:

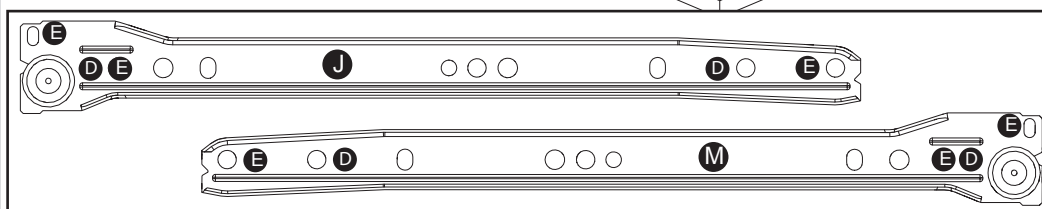
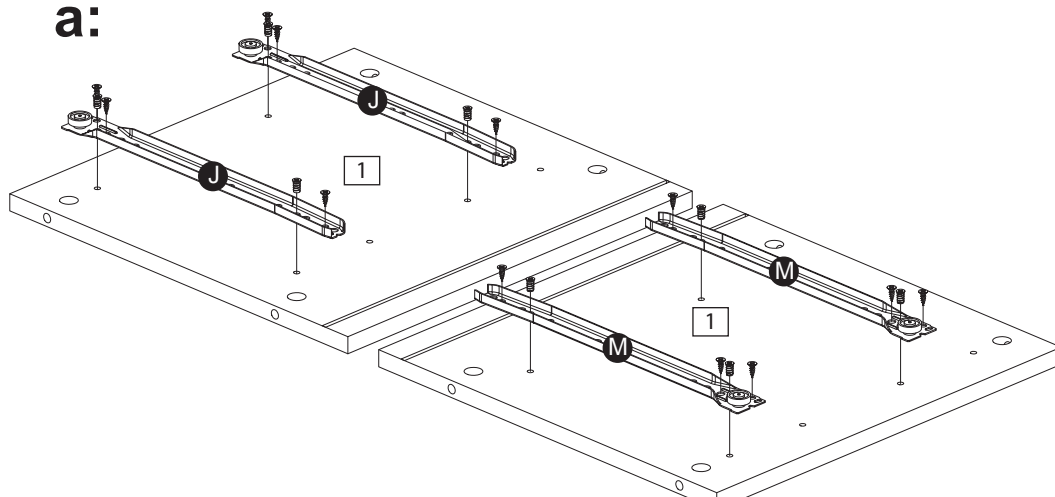

b: Insert 8 Large locking nuts **A** into left & right side **1** where shown. Make sure the 'arrow' on **A** is pointing towards the hole in the edge of **1**.

b:

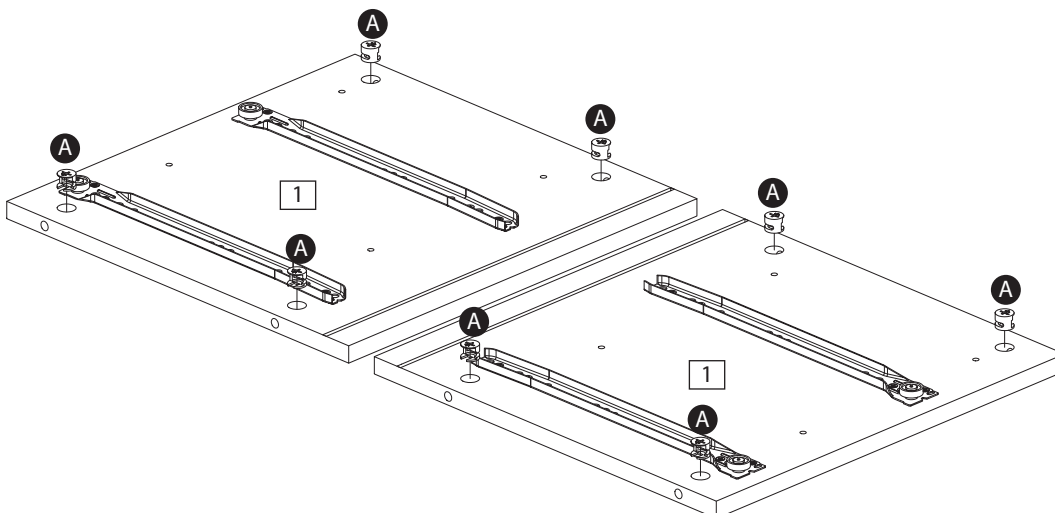

Assembly Instructions

Step 3

Attach bottom and foot

Position bottom **3** onto foot **4** and fix with 30mm chipboard screw **F**.

Screw 24mm locking screws **B** into bottom **3**.

Note: Insert locking screw **B** as far as shown.

Do not over tighten.

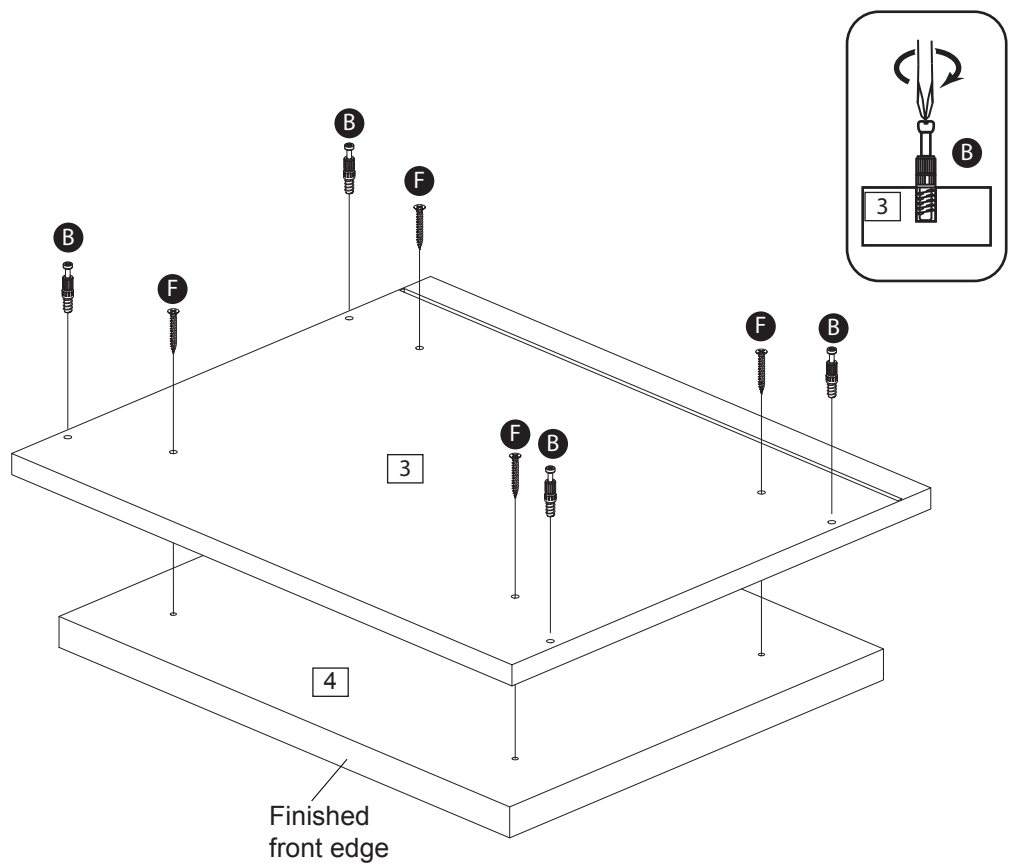

Step 4

Attaching left & right side

Position left & right side **1** onto bottom **3**.

Use a screwdriver to turn locking nuts **A** clockwise to lock.

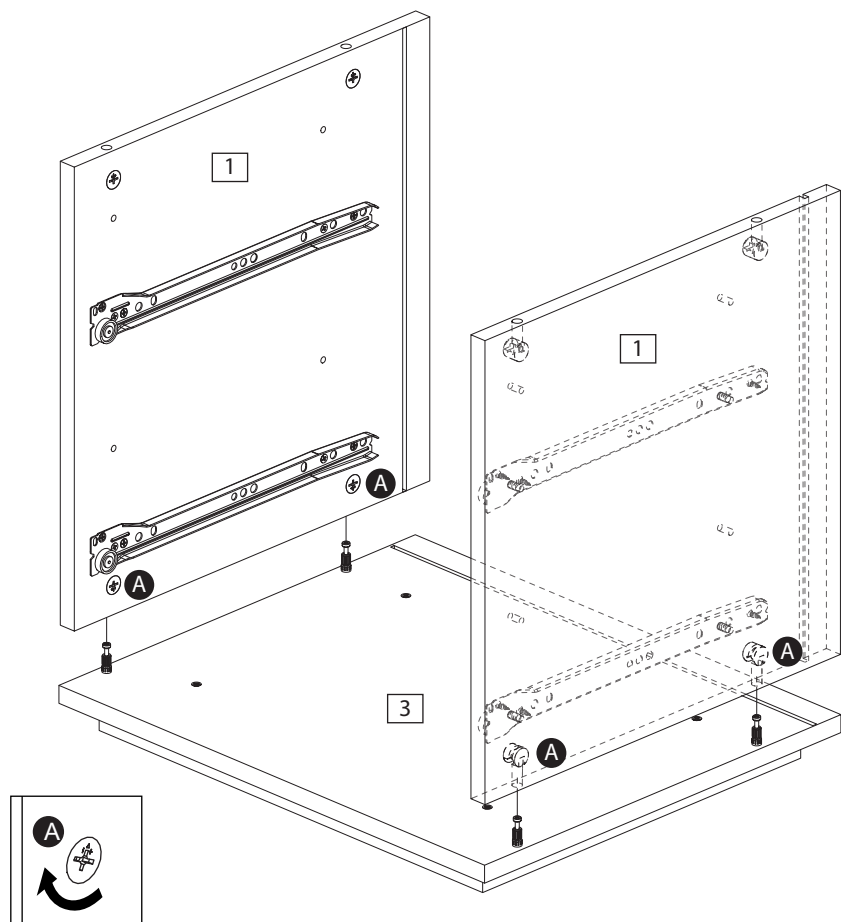

Assembly Instructions

Step 5

Slide in foldy back

Slide foldy back **9** into the grooves in left & right side **1**.

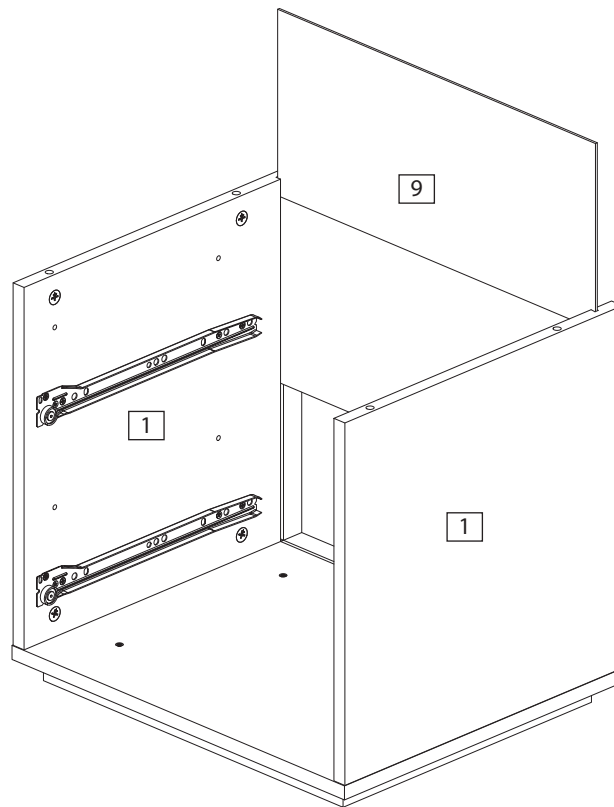

Step 6

a: Prepare top

Screw 4 locking screw **B** into the holes shown on top **2**.

Note: Insert locking screw **B** as far as shown.

Do not over tighten.

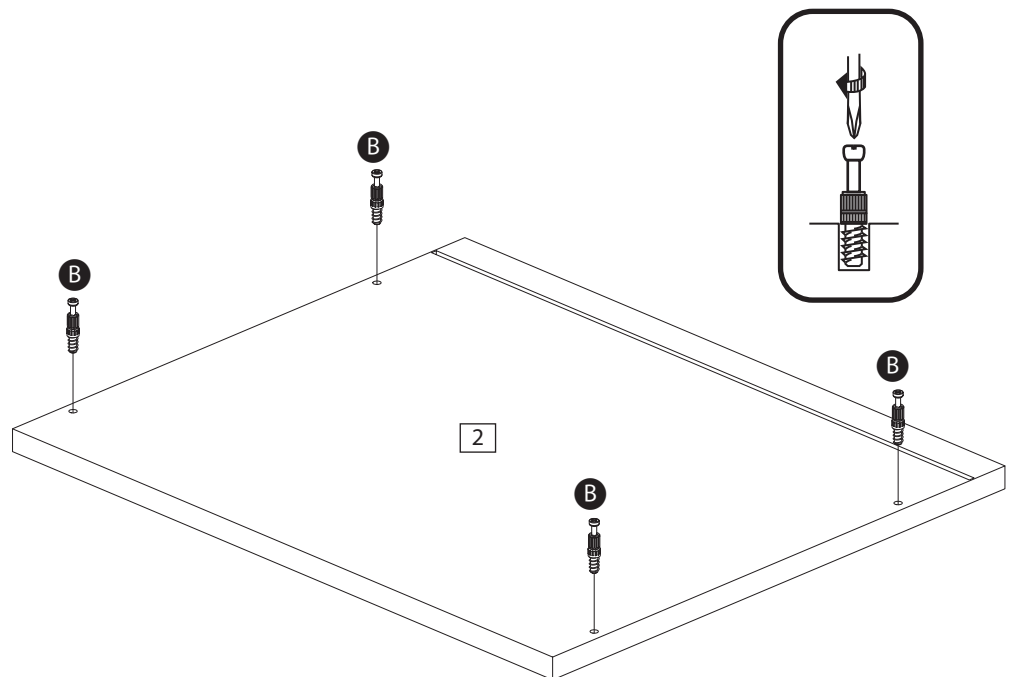

Assembly Instructions

Step 6 continued

b: Attaching top

Position top **2** onto left & right side **1**.

Use a screwdriver to turn locking nuts **A** clockwise to lock.

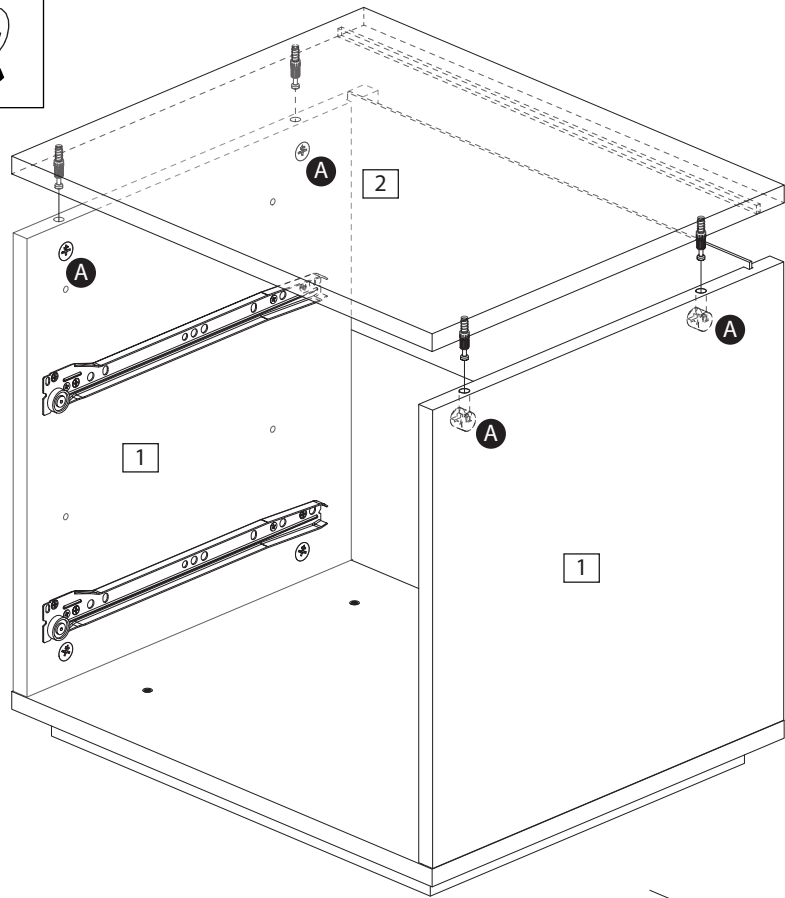
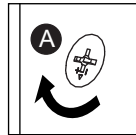

Step 7

Fixate foldy back

Turn over chest and slide drawerbase supports **I** in corner as shown and fix them, using the attached screws.

Stick the selfadhesive felt **G** strategically underneath the foot **4**.

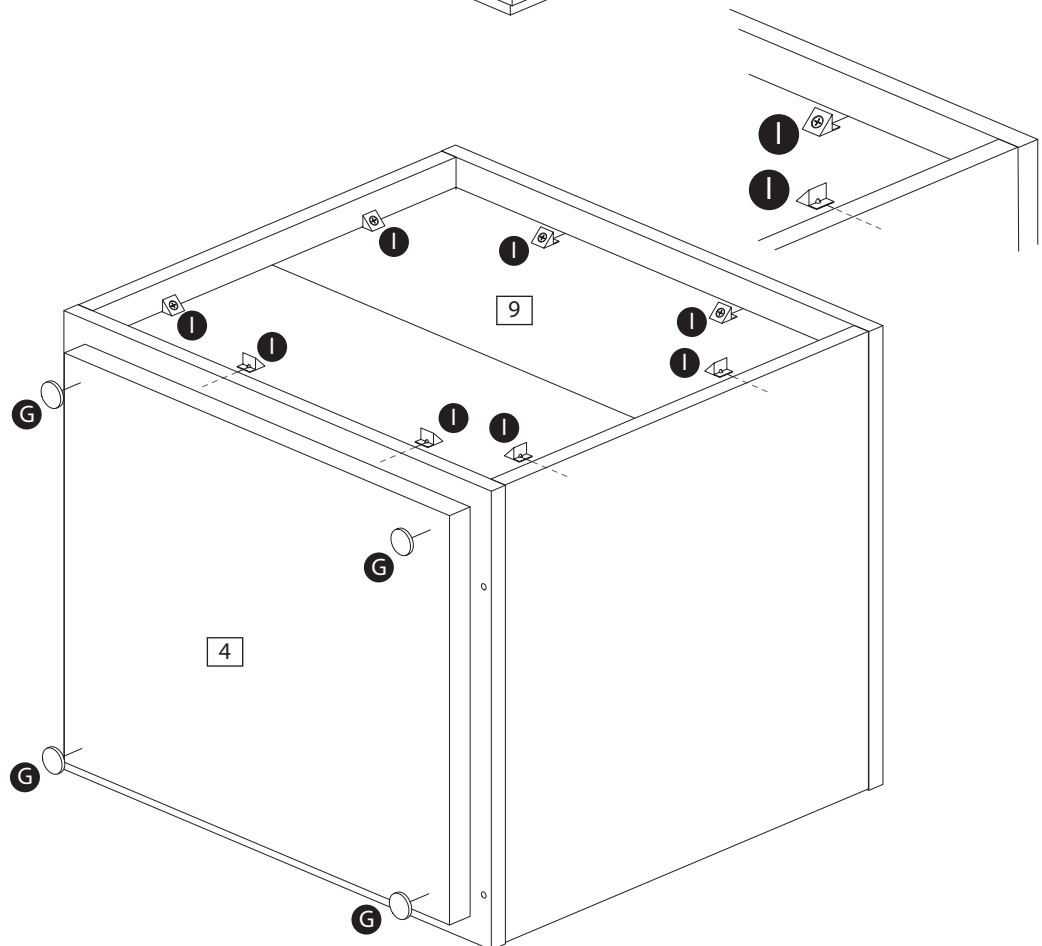

Important:
Chest **MUST**
be 'square'
when back is
attached.

Assembly Instructions

Step 8

Attaching runners

Fix runner left and right side B **K** and **N** on left & right drawer side **6** and **8** as shown using 12,5mm pozi screw **E**.

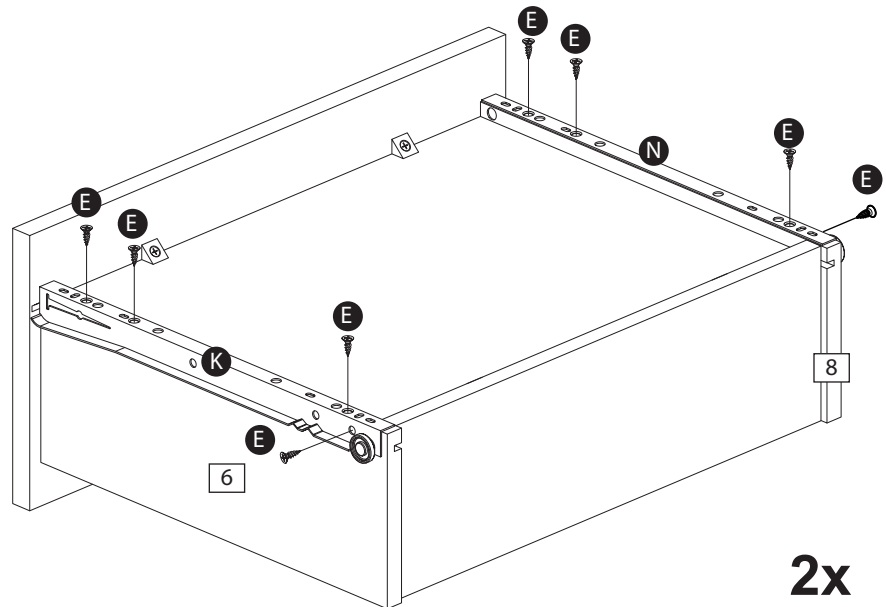

Step 9

Attaching drawer handle

Attach drawer handle **L** on drawer front **5** as shown using 12,5mm pozi screw **E**.

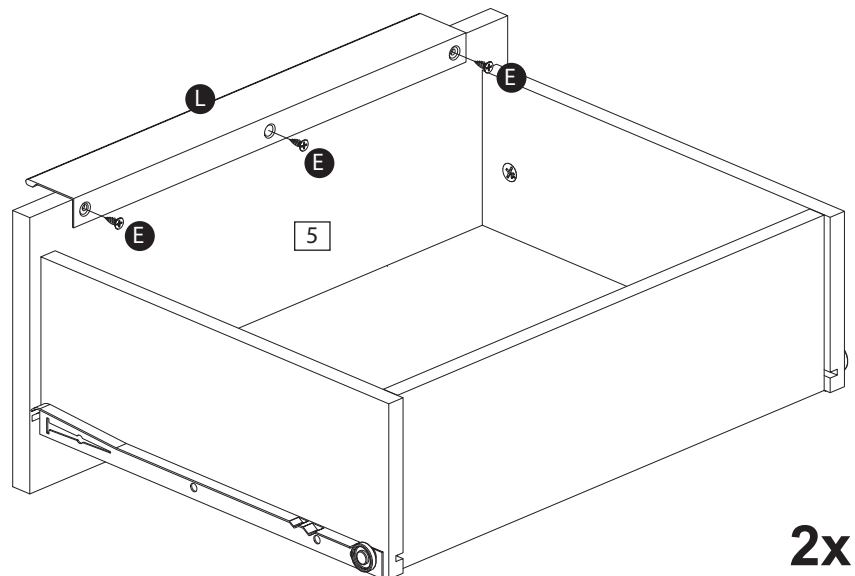

Step 10

Inserting drawers

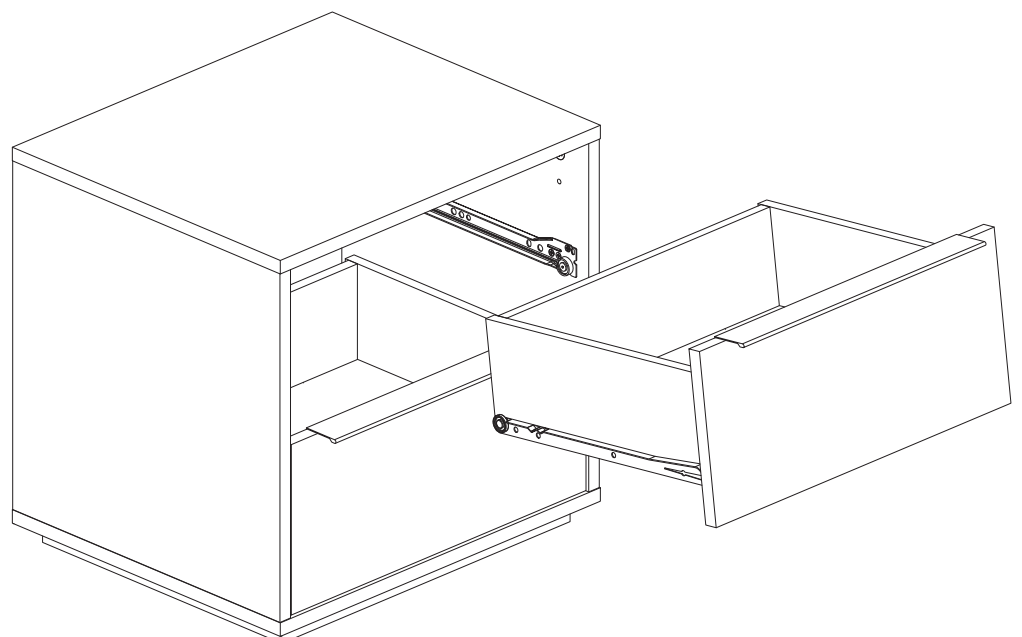

Bergen 3 drawer bedside chest

Assembly Instructions Please keep for future reference

244/7276

228/4532

246/5760

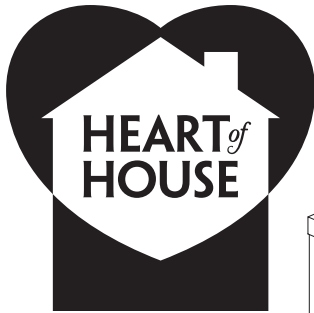

Dimensions

Width - 76.2cm

Depth - 38.1cm

Height - 63.1cm

244/7276 OAK
228/4532 WHT
246/5760 WAL

Tip : To prevent damage, we recommend that you build your unit on the carton(s) it was packed in.

Important – Please read these instructions fully before starting assembly

If you need help or have damaged or missing parts, please visit: www.argos-support.co.uk or email: Help@ClickSpares.co.uk (quoting your original order number)

Alternatively, call the Spares Helpline on: **0370 112 1928**

For any other queries please contact the Customer Helpline on: **0345 640 2020**



Safety and Care Advice

Important – Please read these instructions fully before starting assembly

- Check you have all the components and tools listed on pages 2 and 3.
- Remove all fittings from the plastic bags and separate them into their groups.
- Keep children and animals away from the work area, small parts could choke if swallowed.
- Make sure you have enough space to layout the parts before starting.

- Do not stand or put weight on the product, this could cause damage.
- Assemble the item as close to its final position (in the same room) as possible.
- Assemble on a soft level surface to avoid damaging the unit or your floor.
- Parts of the assembly will be easier with 2 people.



• To reduce the likelihood of damaging your product please ensure that your power drill is set on a low torque setting.

- Dispose of all packaging carefully and responsibly.

Glue safety - Take care when using glue, please follow the advice below

Skin contact: Remove contamination by washing with soap and water. This procedure should also be followed prior to eating and drinking.

Eye contact: Rinse immediately with clean water for 15 minutes and seek medical advice.

If swallowed: Seek medical advice immediately.

Care and maintenance

• Only clean using a damp cloth and mild detergent, do not use bleach or abrasive cleaners.

• From time to time check that there are no loose screws on this unit.

• This product should not be discarded with household waste. Take to your local authority waste disposal centre.

Handy Hints

• Assemble all parts and bolts loosely during assembly, only once the product is complete should you fully tighten the bolts

• Regularly check and ensure that all bolts and fittings are tightened properly.

Note: if required the next page can be cut out and used as reference throughout the assembly. Keep this page with these instructions for future reference.

Components - Panels

For damaged or missing parts, please visit:
www.argos-support.co.uk or email: Help@ClickSpares.co.uk

Please check you have all the panels listed below

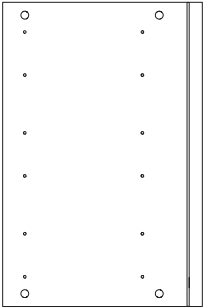

1 Left & Right Side x 2
(57.9 x 38cm)
P2029

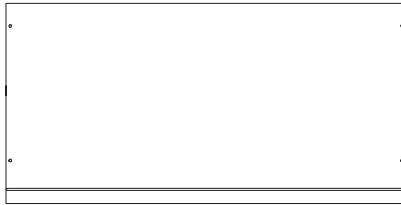

2 Top
(76.2 x 38.1cm)
P1988

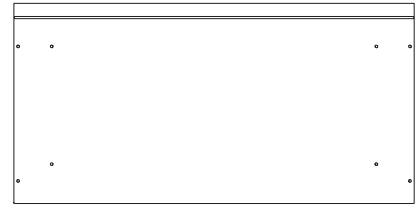

3 Bottom
(76.2 x 38.1cm)
P1989



4 Foot
(71.7x 34cm)
P1990



5 Drawerfront x 3
(72.6 x 18.8cm)
FA4234 / P4234



6 Left Drawer Side x 3
(30.5 x 12cm)
LA163109



7 Drawer Back x 3
(68.2 x 12cm)
LA162609



8 Right Drawer Side x 3
(30.5 x 12cm)
LA163209



9 Foldy Back
(59 x 74.2cm)
BO253909



10 Drawer Base x 3
(69.1 x 29.9cm)
BO253709









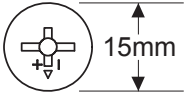
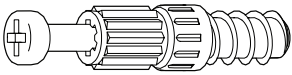

Components - Fittings

For damaged or missing parts, please visit: www.argos-support.co.uk or email: Help@ClickSpares.co.uk

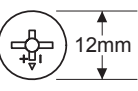
Please check you have all the fittings listed below

Note: The quantities below are the correct amount to complete the assembly. In some cases more fittings may be supplied than are required.

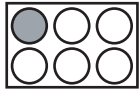
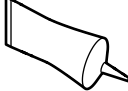
1/1

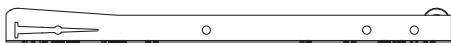
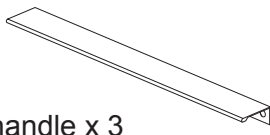
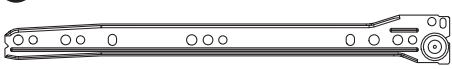
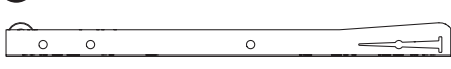
<p>A   FK1012</p> <p>Large locking nut x 8 (15x12mm)</p>	<p>B  FK1011</p> <p>Locking screw x 14 (5x24mm)</p>	<p>C   FK1010</p> <p>Small locking nut x 6 (12x10mm)</p>
<p>D  FK1301</p> <p>10mm Fixing screw drawer x 12</p>	<p>E  FK1309</p> <p>12,5mm Pozi screw x 51</p>	<p>F  FK1322</p> <p>30mm Chipboard screw x 4</p>
<p>G  FK1416</p> <p>Felt selfadhesive x 6</p>	<p>H  FA1510</p> <p>Glue x 1</p>	<p>I  FK1250</p> <p>Drawerbase support x 28</p>
<p>J  PM1516LA</p> <p>Runner left part A x 3</p>	<p>K  PM1516LB</p> <p>Runner left part B x 3</p>	<p>L  GR1978</p> <p>Drawer handle x 3</p>
<p>M  PM1516RA</p> <p>Runner right part A x 3</p>	<p>N  PM1516RB</p> <p>Runner right part B x 3</p>	

Tools required

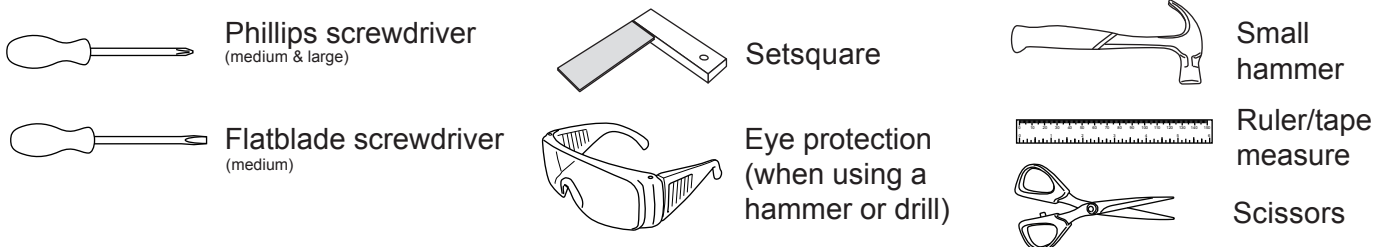

Ruler - Use this ruler to help correctly identify the screws

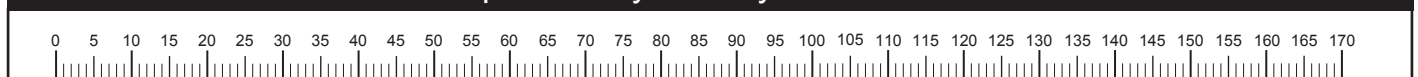

4  The screws length is measured from the head to the point (30mm screw shown).

Assembly Instructions

Step 1

a: Prepare the drawer fronts

Screw 2 locking screw **B** into the holes shown on the back of each drawer front **5**.

Note: Insert locking screw **B** as far as shown. **Do not over tighten.**

a:

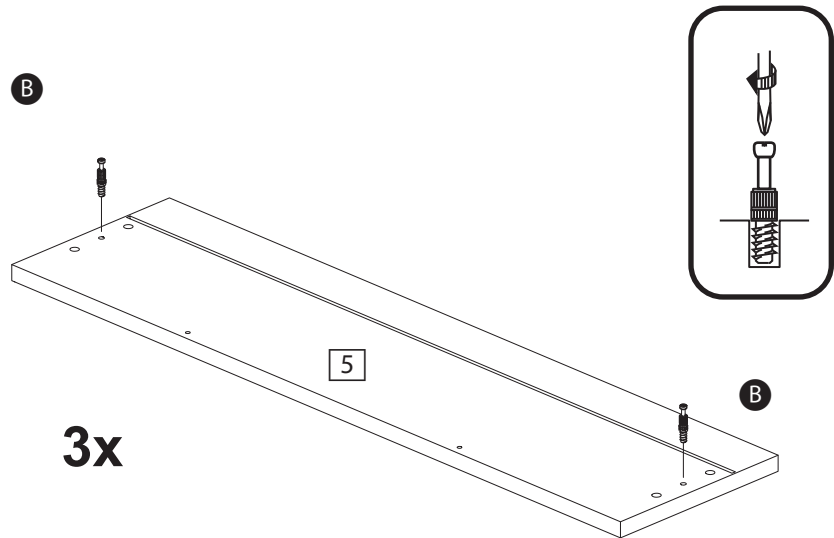

b: Prepare the drawer sides

Insert a small locking nut **C** into the hole on left drawer side **6** and right drawerside **8**.

Make sure the 'arrow' on **C** is pointing towards the hole in the edge of **6** and **8**.

Put drop of glue **J** in the 6 holes of drawersides **6** and **8** before sliding them onto the dowels of drawerback **7**.

Slide drawerbase **10** in the grooves of the drawer-unit.

b:

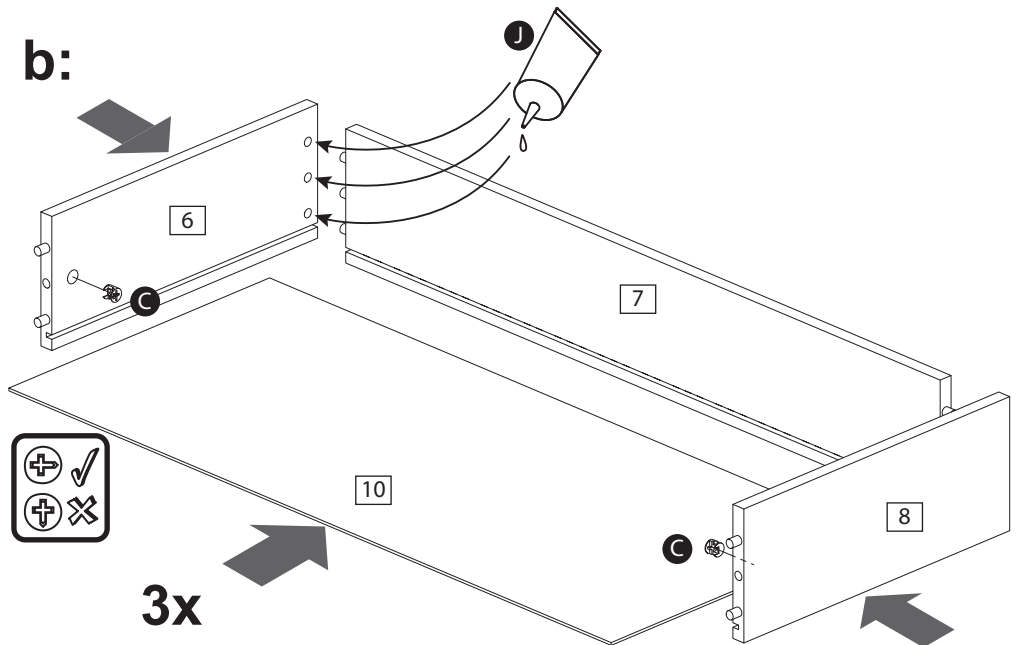

c: Turn the drawer wrap assembly over and push onto the drawer front **5**. Use a phillips or flatblade screwdriver, that is a good fit, to turn 24mm locking nut **C** as far as it will go - more than 1/2 turn.

c:

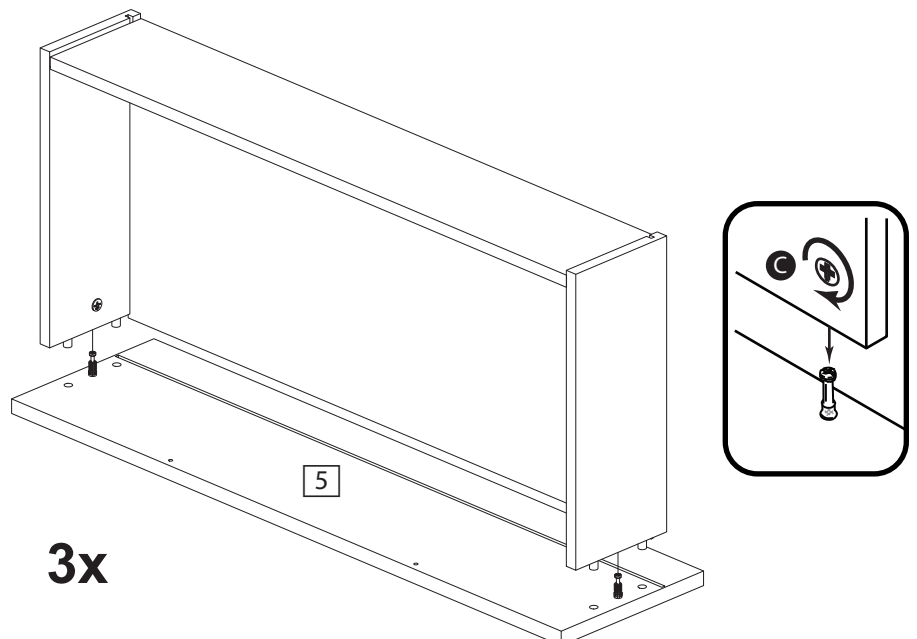

Assembly Instructions

Step 1 continued

finishing the drawers

d: Turn over drawer and slide drawerbase supports **l** in corner as shown and fix them, using the attached screws .

d:

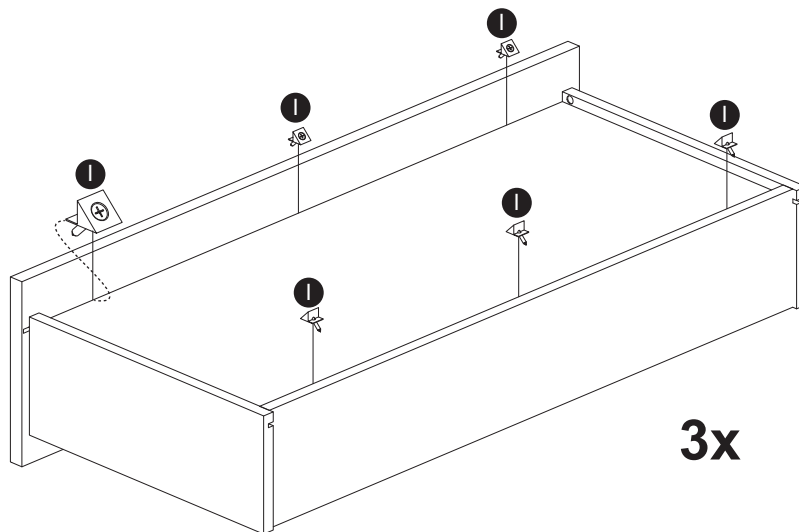

Step 2

Attaching runners

a: Fix runner left and right side **A** **J** and **M** on left & right side **1** as shown using 10mm fixing screw drawer **D** and 12,5mm pozi screw **E**.

a:

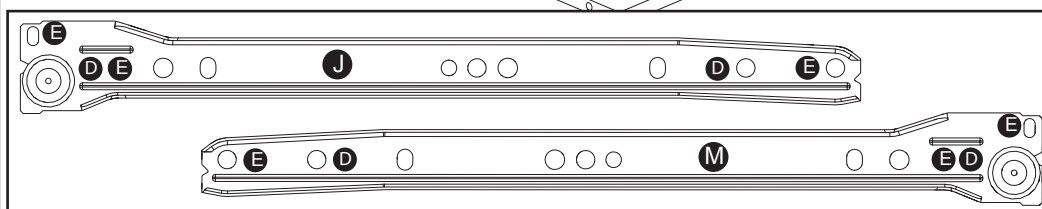
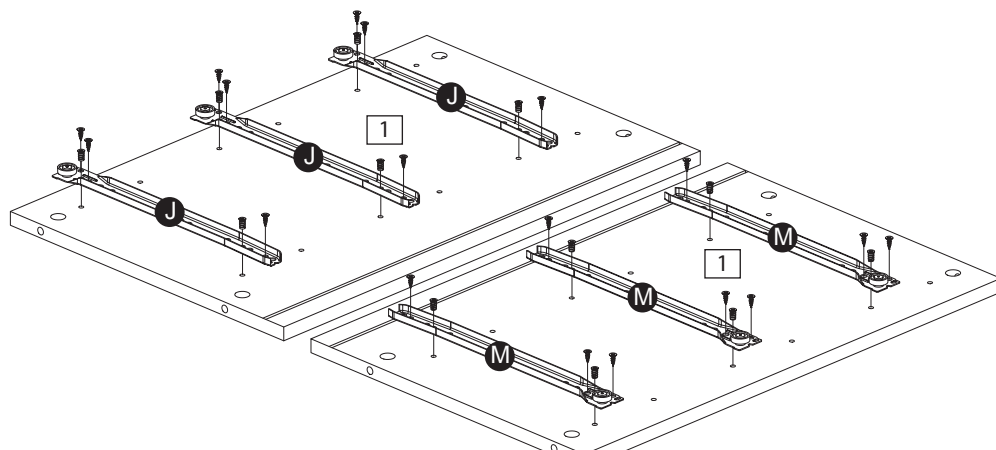

b: Insert 8 Large locking nuts **A** into left & right side **1** where shown. Make sure the 'arrow' on **A** is pointing towards the hole in the edge of **1**.

b:

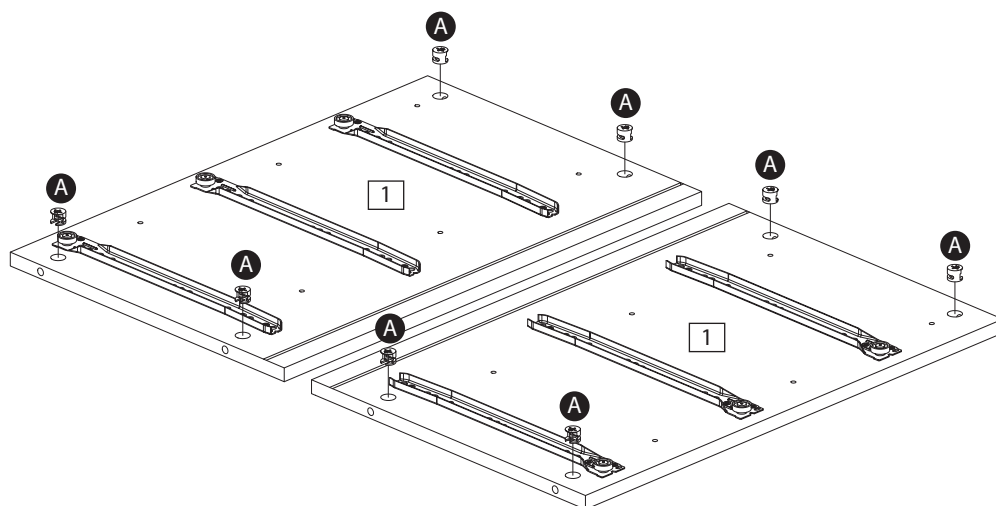

Assembly Instructions

Step 3

Attach bottom and foot

Position bottom **3** onto foot **4** and fix with 30mm chipboard screw **F**.

Screw 24mm locking screws **B** into bottom **3**.

Note: Insert locking screw **B** as far as shown. **Do not over tighten.**

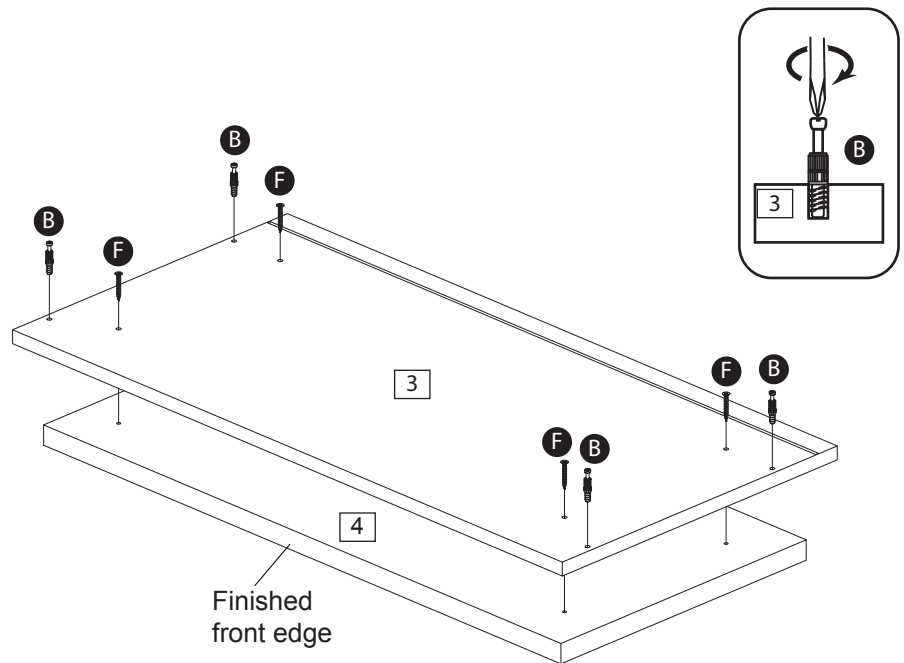

Step 4

Attaching left & right side

Position left & right side **1** onto bottom **3**.

Use a screwdriver to turn locking nuts **A** clockwise to lock.

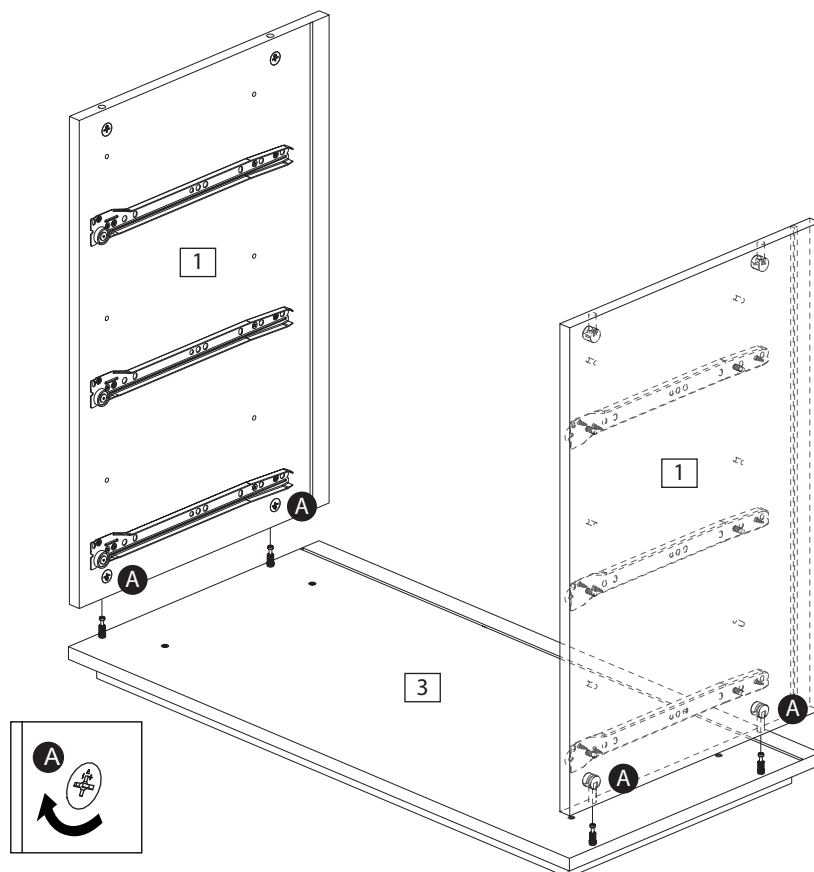

Assembly Instructions

Step 5

Slide in foldy back

Slide foldy back **9** into the grooves in left & right side **1**.

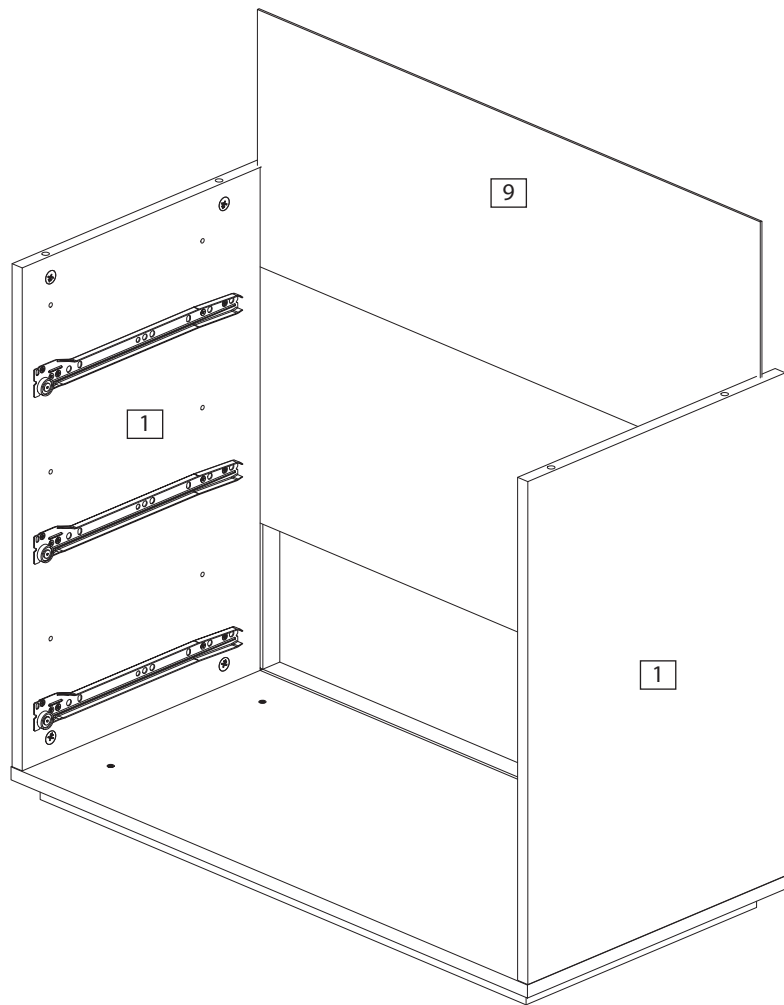

Step 6

a: Prepare top

Screw 4 locking screw **B** into the holes shown on top **2**.

Note: Insert locking screw **B** as far as shown. **Do not over tighten.**

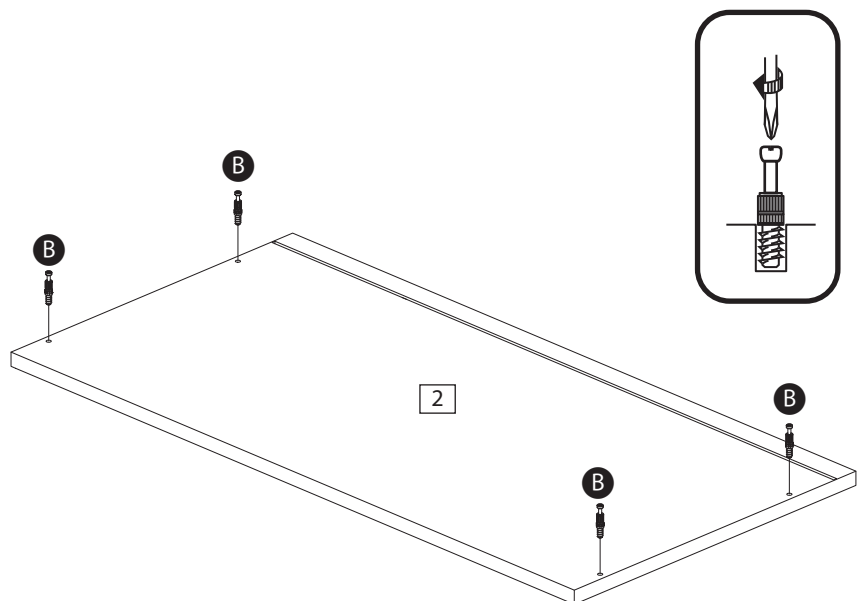

Assembly Instructions

Step 6 continued

b: Attaching top

Position top **2** onto left & right side **1**.

Use a screwdriver to turn locking nuts **A** clockwise to lock.

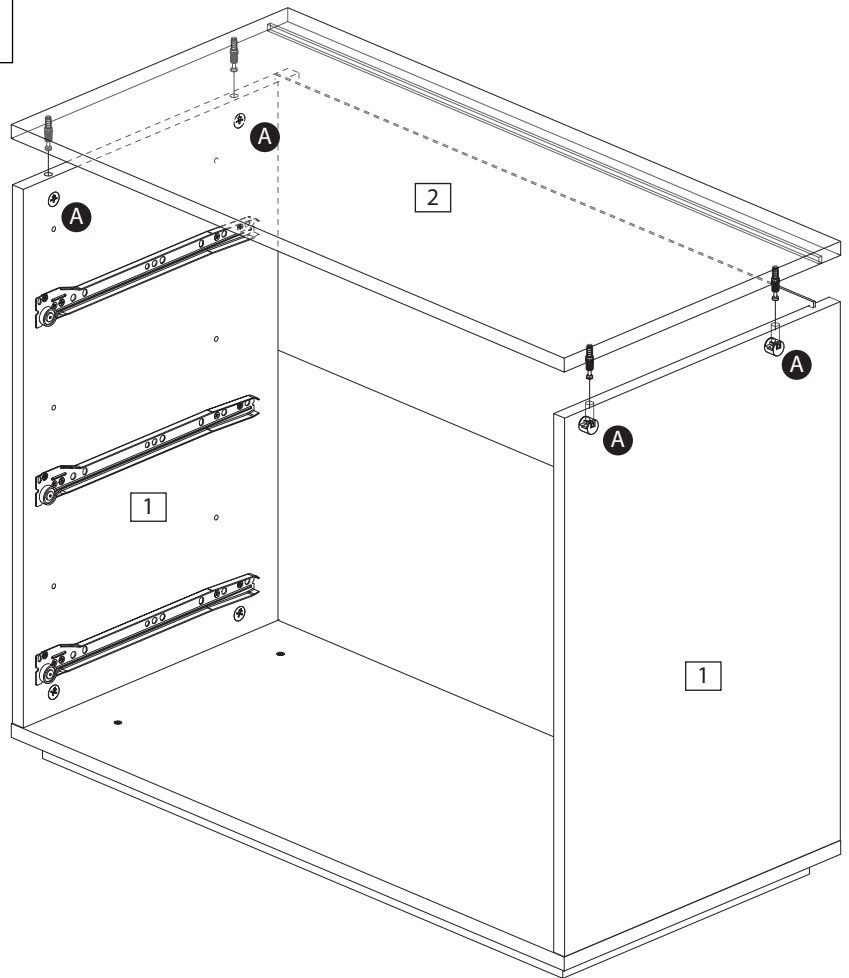
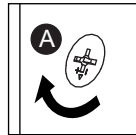

Step 7

Fixate foldy back

Turn over chest and slide drawerbase supports **I** in corner as shown and fix them, using the attached screws.

Stick the selfadhesive felt **G** strategically underneath the foot **4**.

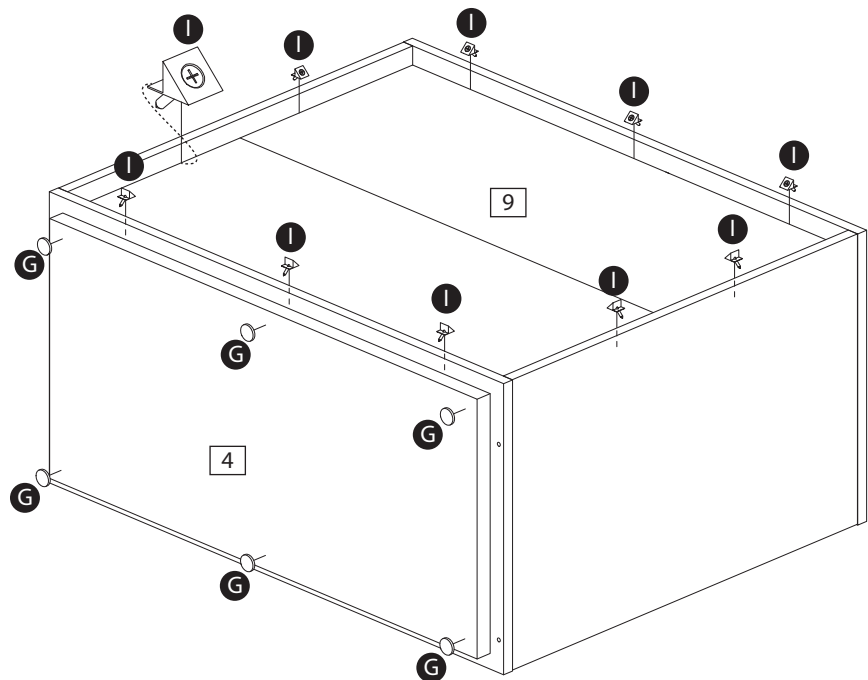

Important:
Chest **MUST**
be 'square'
when back is
attached.

Assembly Instructions

Step 8

Attaching runners

Fix runner left and right side B **K** and **N** on left & right drawer side **6** and **8** as shown using 12,5mm pozi screw **E**.

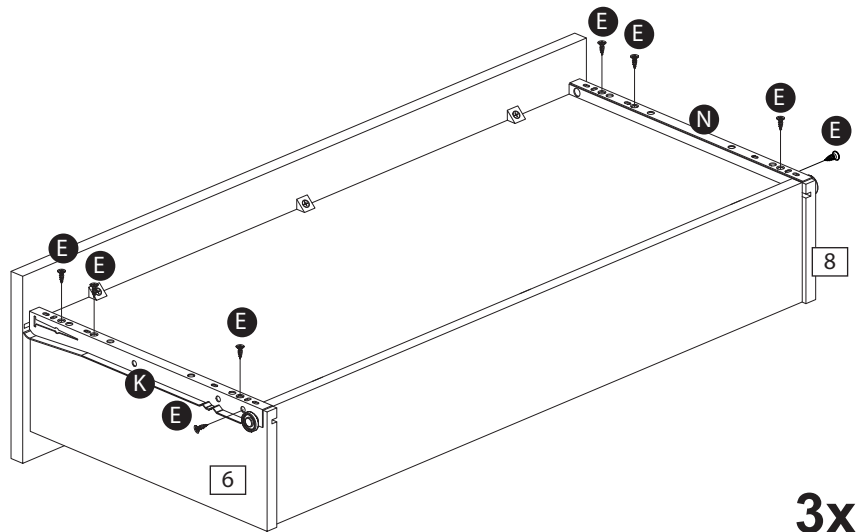

3x

Step 9

Attaching drawer handle

Attach drawer handle **L** on drawer front **5** as shown using 12,5mm pozi screw **E**.

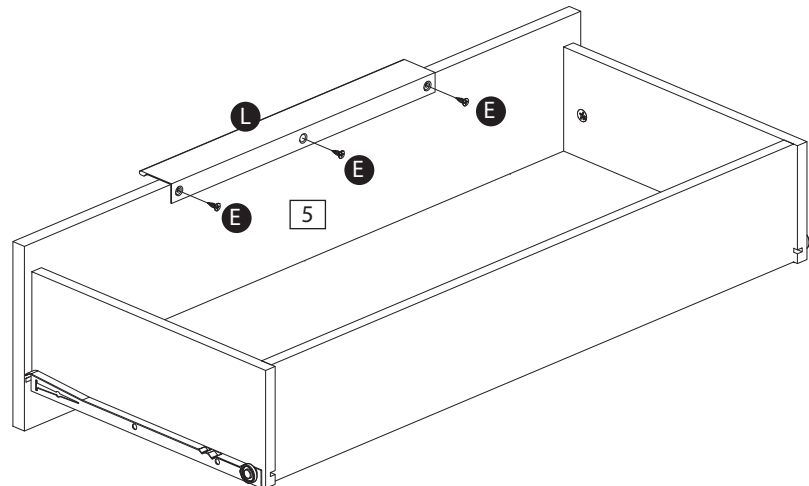

3x

Step 10

Inserting drawers

