

Large Shaped Corner Desk

Assembly Instructions - Please keep for future reference

213/4864

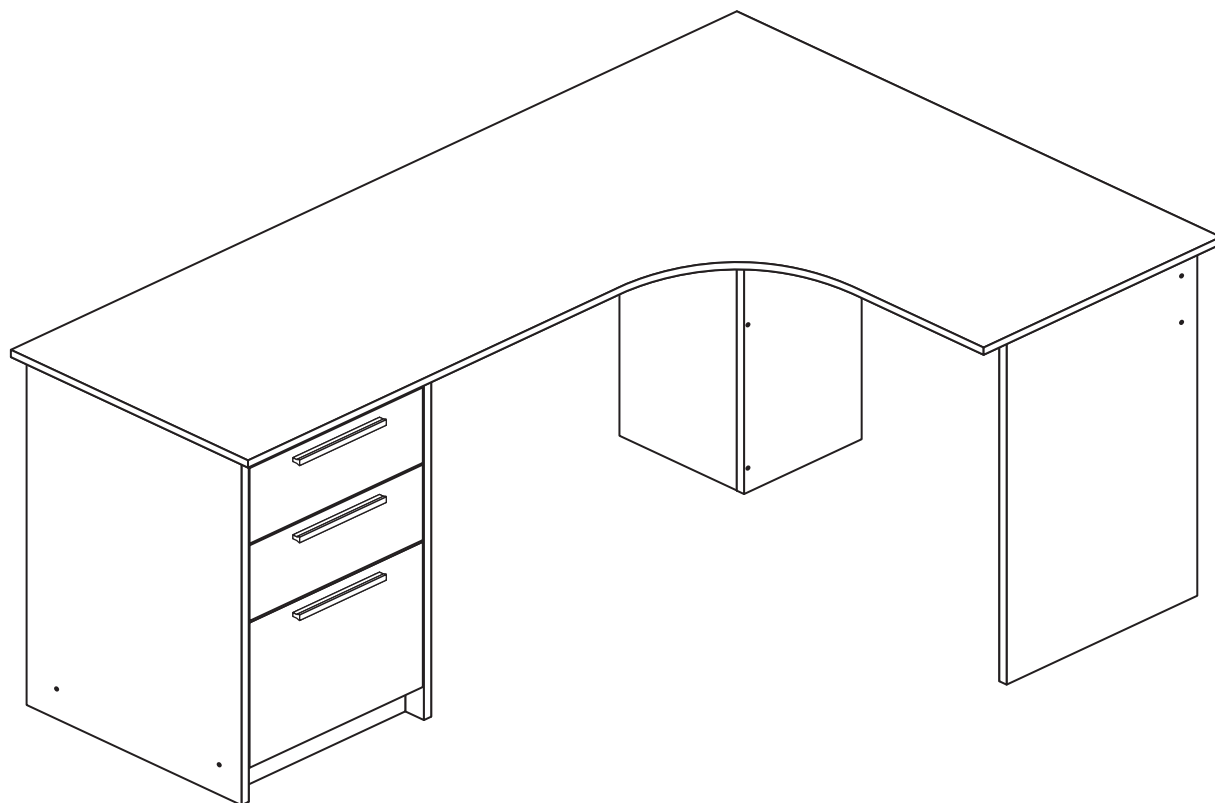

Dimensions

Width - 150cm

Depth - 100cm

Height - 73cm



**MADE IN
BRITAIN**

Important - Please read these instructions fully before starting assembly

If you need help or have damaged or missing parts, call the **Customer Helpline: 08456 400800**



Safety and Care Advice

Important - Please read these instructions fully before starting assembly

- **Warning:** This unit weighs approximately 36kgs. Please lift with care.

- Check you have all the components and tools listed on pages 2 and 3.

- Remove all fittings from the plastic bags and separate them into their groups.

- Keep children and animals away from the work area, small parts could choke if swallowed.

- Parts of the assembly will be easier with 2 people.

- Make sure you have enough space to layout the parts before starting.

- Do not stand or put weight on the product, this could cause damage.

- Assemble the item as close to its final position (in the same room) as possible.

- Assemble on a soft level surface to avoid damaging the unit or your floor (use opened out unit carton).



- We do not recommend the use of power drill/drivers **for inserting screws**, as this could damage the unit. Only use hand screwdrivers.

- **Safety note:** If there is any chance of this unit being pulled over by children etc. it is recommended that the unit is secured to a wall using suitable fixings (not supplied).

- Dispose of all packaging carefully and responsibly.

Care and maintenance

- Only clean using a damp cloth and mild detergent, do not use bleach or abrasive cleaners.

- From time to time check that there are no loose screws on this unit.

- This product should not be discarded with household waste. Take to your local authority waste disposal centre.

Tools required

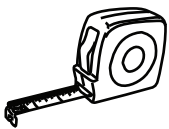

Rule



Cross-head screwdriver



Scissors



Hammer



Eye protection (when using a hammer or drill)

Note: If required the next page can be cut out and used as reference throughout the assembly. Keep this page with these instructions for future reference.

Components - Panels

If you have damaged or missing components, call the **Customer Helpline: 08456 400800** quoting the reference numbers below

Please check you have all the panels listed below

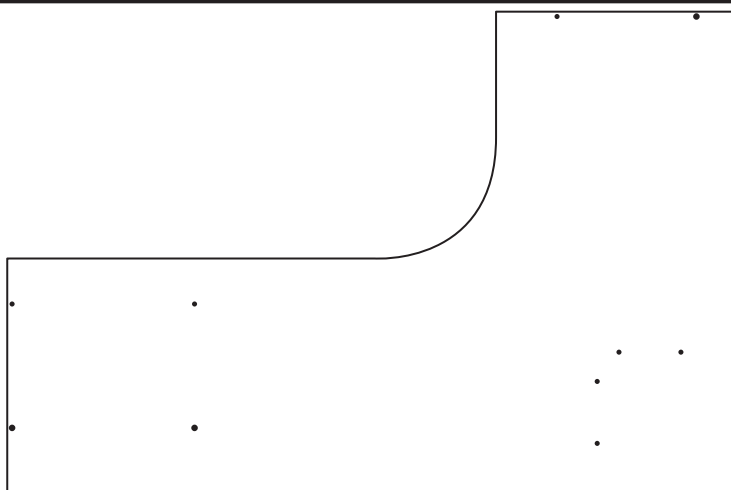

1 Desktop (DF729)
(1500 x 1000mm)



2 Right End (DF730)
(706 x 394mm)

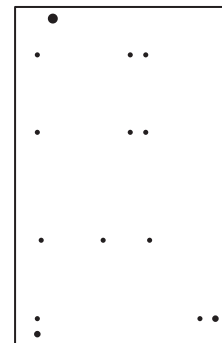

3 Filer Left Side (DF958)
(706 x 444mm)

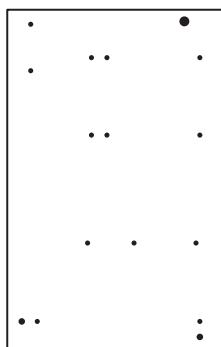

4 Filer Right Side (DF942)
(706 x 444mm)



5 Left Upright (DF731)
(706 x 243mm)

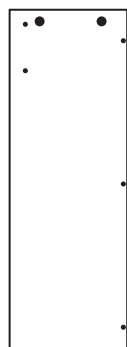

6 Right Upright (DF732)
(706 x 243mm)



7 Small Modesty (DF733)
(678.5 x 174mm)



8 Large Modesty (DF811)
(817 x 174mm)

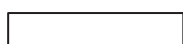

9 Rail (D0858A)
(362 x 80mm) x 2

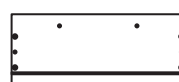

10 Drawer Front (DF944)
(358 x 156mm) x 2



11 Left Drawer Side (W370-124LH)
(370 x 124mm) x 2



12 Right Drawer Side (W370-124RH)
(370 x 124mm) x 2



13 Drawer Back (W331-124LH)
(331 x 124mm) x 2

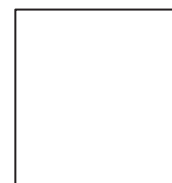

14 Drawer Base (T342-367)
(342 x 367mm) x 2

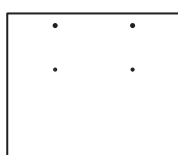

15 File Front (DF943)
(358 x 300mm)

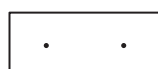

16 File Wrap (FW312-124)
(312 x 124mm) x 2

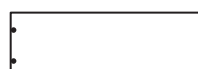

17 File Side (FW400-124)
(400 x 124mm) x 2



18 Back (X807)
(390 x 650mm)











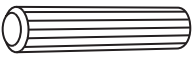
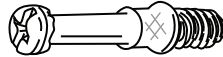

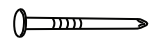

Components - Fittings

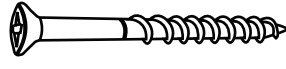
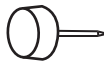
If you have damaged or missing components, call the **Customer Helpline: 08456 400800** quoting the reference numbers below

Please check you have all the fittings listed below

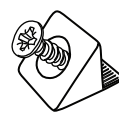
Note: The quantities below are the correct amount to complete the assembly. In some cases more fittings may be supplied than are required.

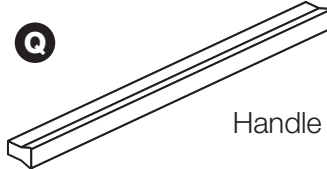
<p>A </p> <p>Wooden dowel (F22) x 7</p>	<p>B </p> <p>Metal dowel (F901) x 11</p>	<p>C </p> <p>Knock-in Peg (F171GY) x 16</p>
<p>D </p> <p>Small locking nut (F3) x 4</p>	<p>E </p> <p>Large locking nut (F900) x 7</p>	<p>F </p> <p>Nail (F51) x 14</p>
<p>G </p> <p>40mm Screw (F910) x 12</p>	<p>H </p> <p>25mm Screw (F50) x 8</p>	<p>I </p> <p>45mm Screw (F65) x 3</p>
<p>J </p> <p>Plastic Nail (F91) x 10</p>	<p>K </p> <p>13mm Screw (F52) x 6</p>	<p>L </p> <p>13mm Screw (F63) x 6</p>
<p>M </p> <p>9mm Screw (F74) x 4</p>	<p>N </p> <p>9mm Screw (F73) x 8</p>	<p>O </p> <p>Wedgefix (F639) x 4</p>
<p>P </p> <p>Drawer runner (F1004) x 4</p>		<p>Q </p> <p>Handle (F262) x 3</p>

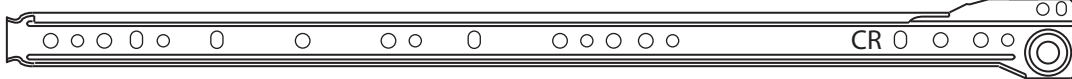
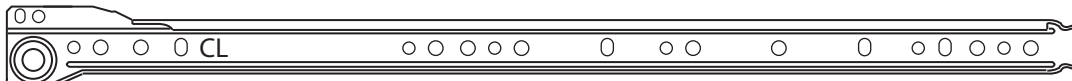
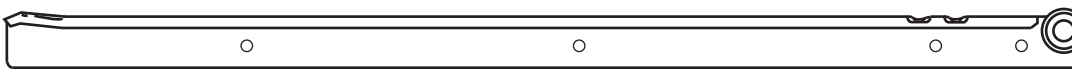
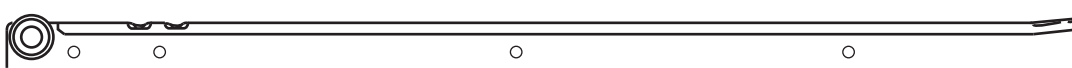
<p>R a </p>	<p>CR Runner (F903) x 1</p>
<p>R b </p>	<p>CL Runner (F904) x 1</p>
<p>R c </p>	<p>DR Runner (F905) x 1</p>
<p>R d </p>	<p>DL Runner (F906) x 1</p>

Ruler - Use this ruler to help correctly identify the screws



Assembly Instructions

If you have damaged or missing components, call the **Customer Helpline: 08456 400800** quoting the reference numbers below

Step 1

Prepare the 2 drawer fronts

Screw 2 metal dowels **B** into each of the drawer fronts **10**.

Note: Tighten the metal dowels up fully against the panels.

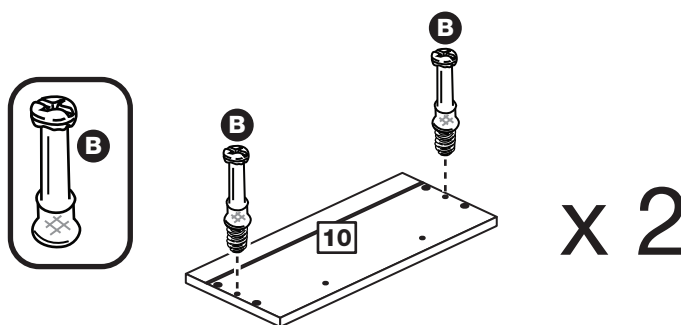

Step 2

Prepare the drawer sides

Insert a small locking nut **D** into the hole shown on the left drawer side **11** and the right drawer side **12**.

Note: The arrow on the locking nut **must** point towards the hole in the edge of the panel.

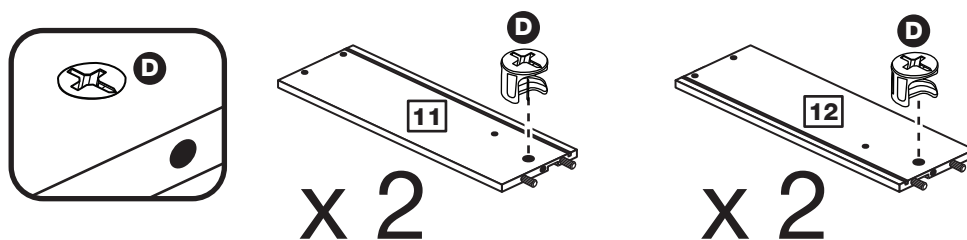

Step 3

Attach the drawer sides to the drawer fronts

Push the left drawer sides **11** and right drawer sides **12** onto the back of the drawer fronts **10**.

Turn the small locking nuts **D** on the left drawer side **11** and right drawer side **12**.

Note: Turn the locking nuts **D** clockwise to secure panels - more than 1/2 a turn.

Note: The locking nuts can be on either surface of the drawer sides. Make sure that the small groove is on the inside, as shown.

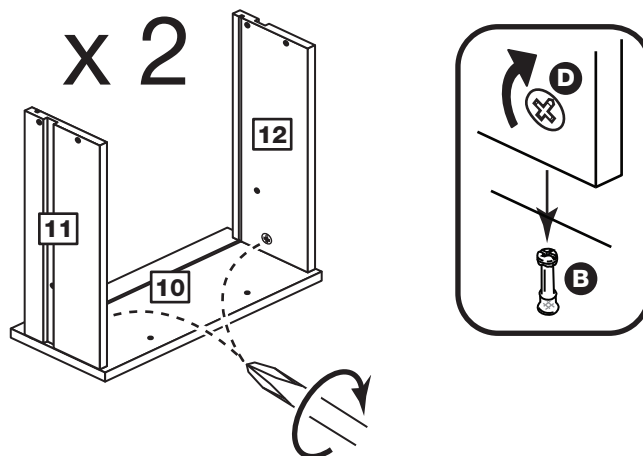

Assembly Instructions

Step 4

Fit the drawer base

Slide the drawer base **14** down the grooves in the drawer sides **11** and **12** and down into the groove in the drawer front **10**.

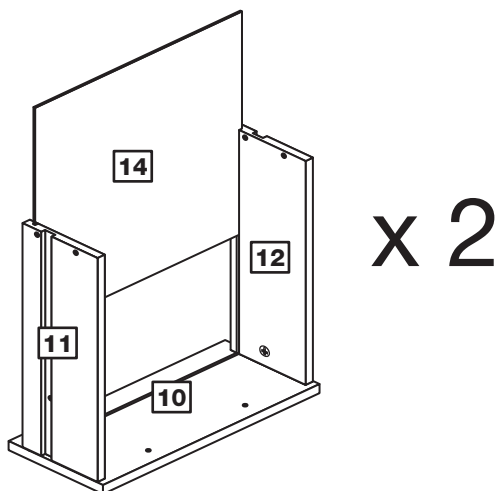

Step 5

Fit the drawer back

Fit the drawer back **13** between the drawer sides **11** and **12**. Make sure that the drawer base **14** fits into the groove in the drawer back **13**.

Hold the drawer back **13** in position and tap the knock-in pegs **C** through the holes in the drawer sides **11** and **12**.

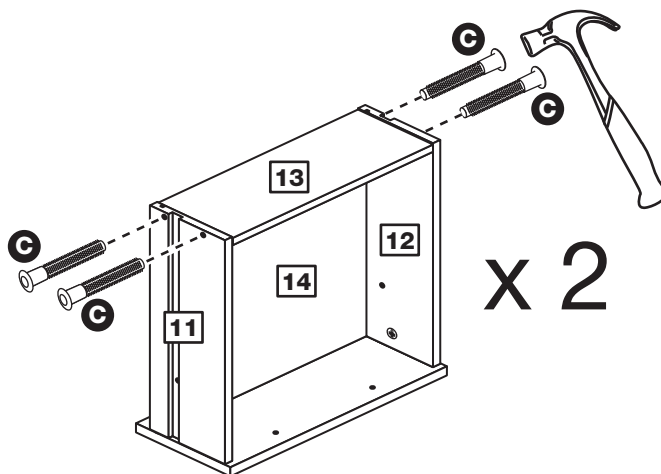

Step 6

Attach the handles

Attach a handle **Q** to each of the drawer fronts **10** using screw **H**.

Note: Do not overtighten the screw.

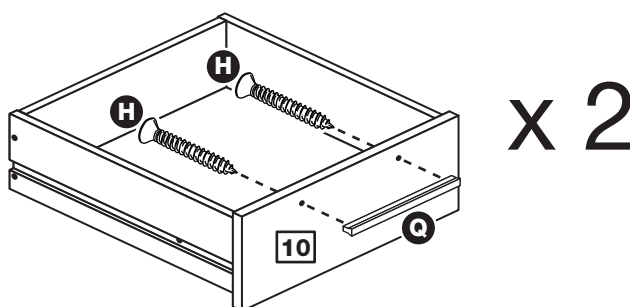

Step 7

Fit the wedgifixes

Turn the drawer assemblies over and slide 2 wedgifixes **O** into the front and back grooves, as shown, and tighten up the screws.

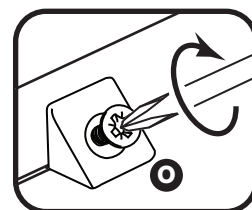
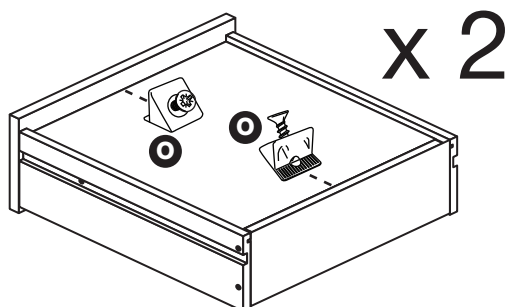

Assembly Instructions

Step 8

Fit a file side to the file wraps

Position a file side **17** onto 2 file wraps **16**, as shown.

Tap 4 knock-in pegs **C** through the holes in the file side **17** and into the file wraps **16**.

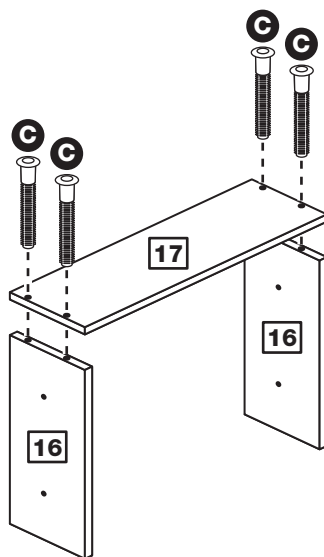

Step 9

Fit the other file side to the file wraps

Position the file side **17** onto 2 file wraps **16**, as shown.

Tap 4 knock-in pegs **C** through the holes in the file side **17** and into the file wraps **16**.

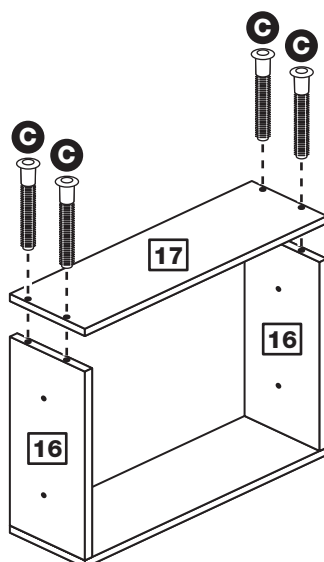

Step 10

Fit the file front

Fit the file front **15** to one of the file wraps **16** by screwing into the shallow mark holes on the back surface of the file front **15** using 2 screws **H**.

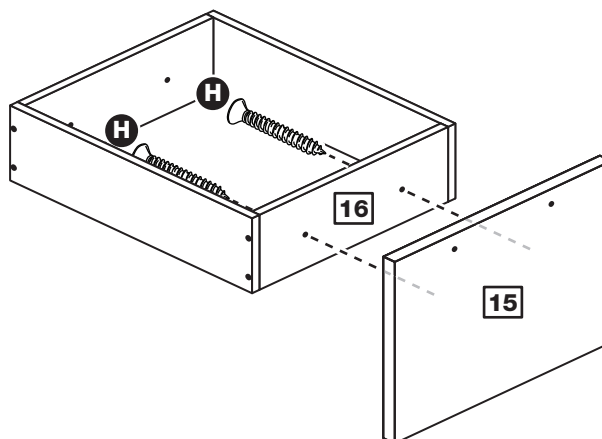

Assembly Instructions

Step 11

Attach the handles

Attach a handle **Q** to the file front **15** using screw **H**.

Note: Do not overtighten the screw.

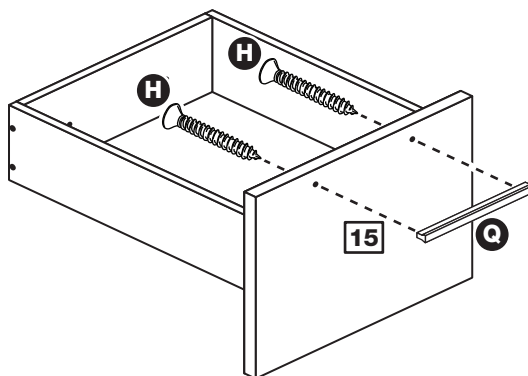

Step 12

Fit the runners to the file sides

Turn the file drawer assembly over.

Fit runner **Rc**, marked with 'DR', to the bottom edge of the right file side **17** as shown, making sure that it is pushed up against the back of the file front **15**. Use a bradawl to mark the fixing positions, then secure with 2 screws **L**.

Fit runner **Rd**, marked 'DL', to the bottom edge of the left file side using the same method.

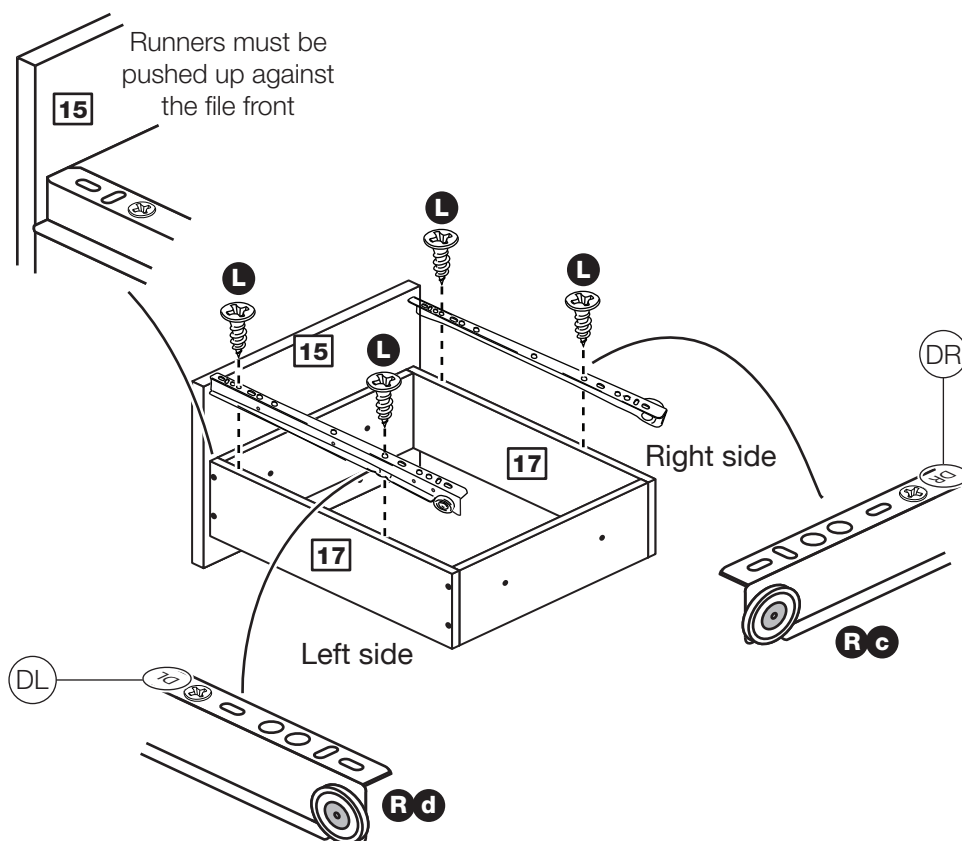

Assembly Instructions

Step 13

Prepare the desktop

Screw 7 metal dowels **B** into the desktop **1**.

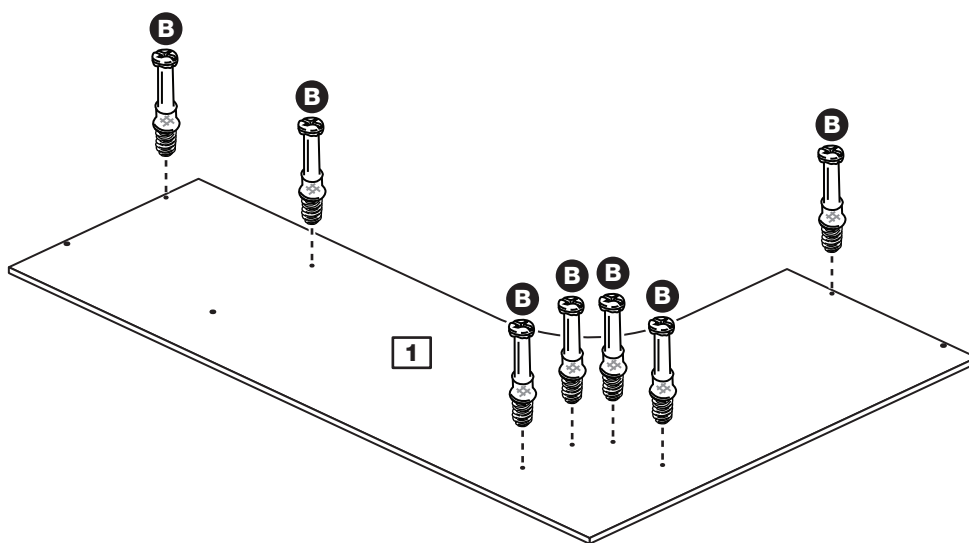

Step 14

Prepare the right end

Insert a large locking nut **E** into the right end **2**.

Note: The arrow on the locking nut **must** point towards the hole in the edge of the panel.

Tap a wooden dowel **A** into the right end **2**.

Note: Wooden dowels **must not** stick out from the edge by more than 10mm or they may damage other panels.

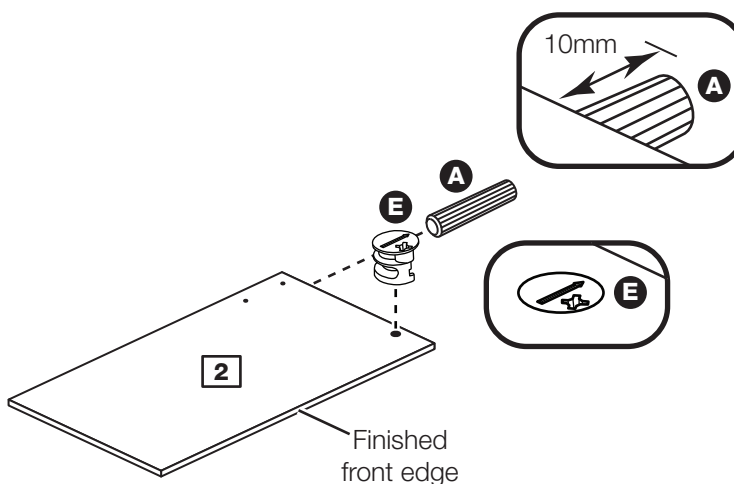

Assembly Instructions

Step 15

Fit the right end to the desktop

Push the right end **2** down onto the desktop **1**.

Use a screwdriver to tighten the large locking nut **E** fitted to the right end **2**.

Note: Turn the large locking nuts **E** as far as they will go - more than 1/2 a turn.

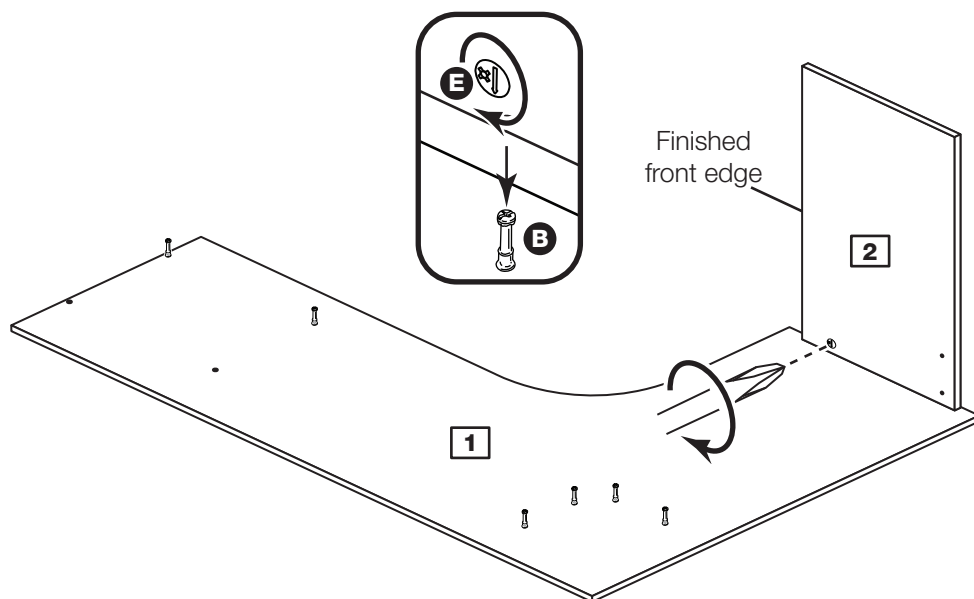

Step 16

Fit the small modesty to the right end

Attach the small modesty **7** to the right end **2** using 2 screws **G**.

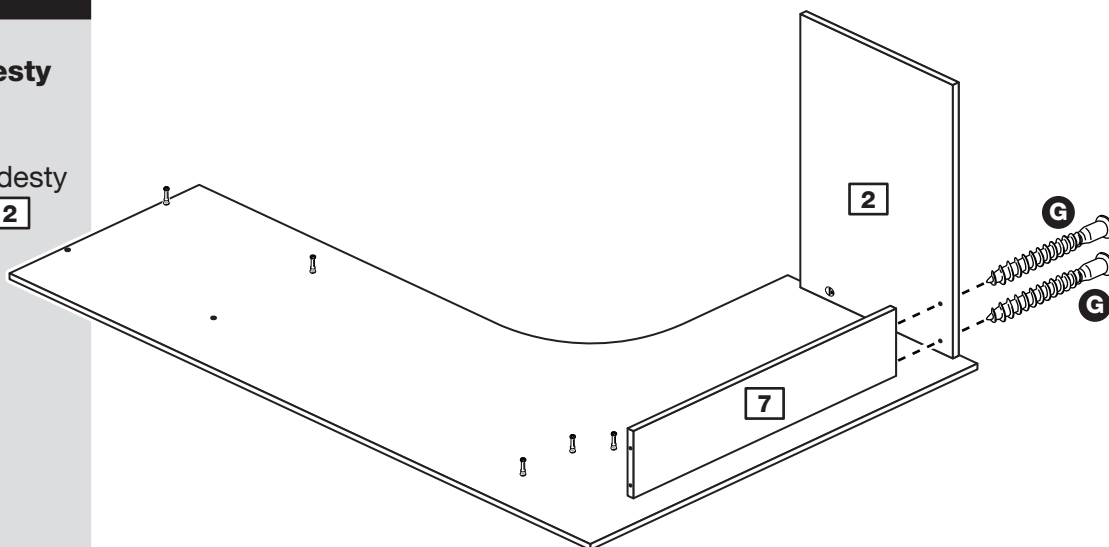

Step 17

Prepare the right upright

Insert 2 large locking nuts **E** into the right upright **6**.

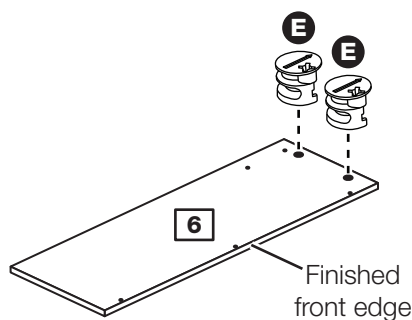

Assembly Instructions

Step 18

Fit the right upright to the desktop

Push the right upright **6** down onto the desktop **1**.

Use a screwdriver to tighten the 2 large locking nuts **E** fitted to the right upright **6**.

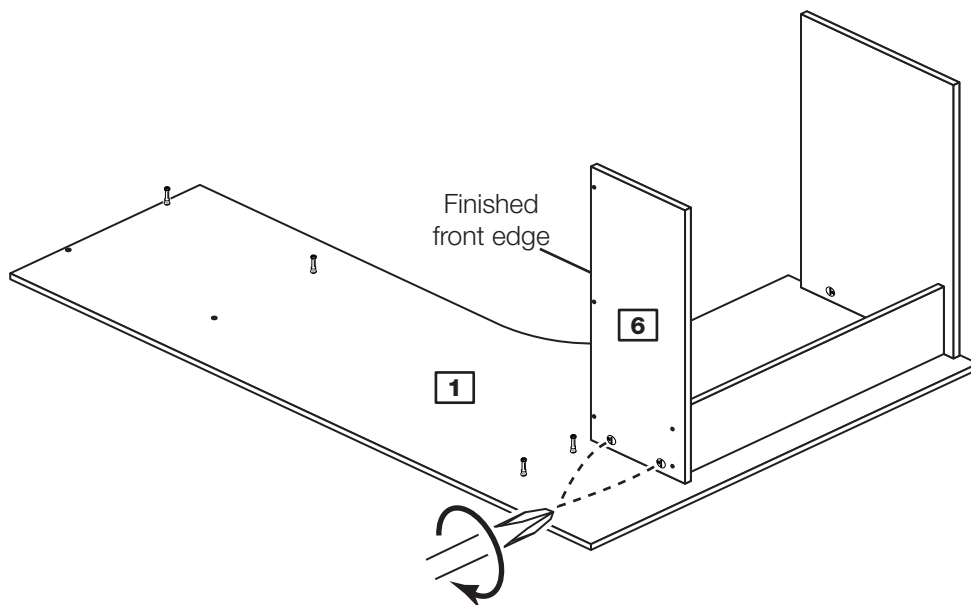

Step 19

Fit the right upright to the small modesty

Attach the right upright **6** to the small modesty **7** using 2 screws **G**.

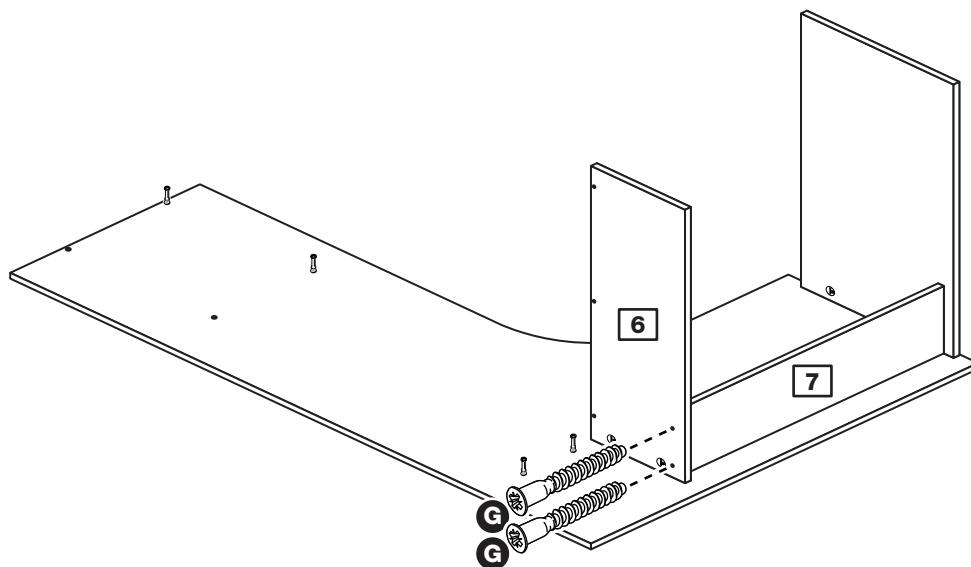

Step 20

Prepare the left upright

Insert 2 large locking nuts **E** into the left upright **5**.

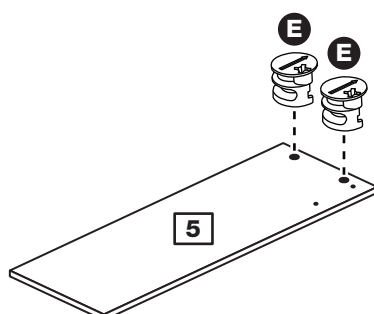

Assembly Instructions

Step 21

Fit the left upright to the desktop

Push the left upright **5** down onto the desktop **1**.

Use a screwdriver to tighten the 2 large locking nuts **E** fitted to the left upright **5**.

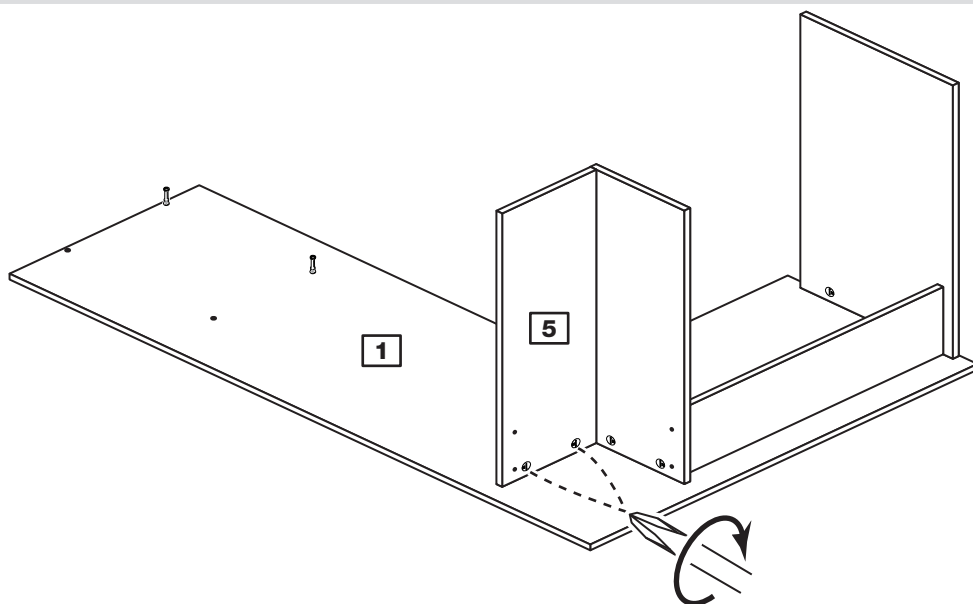

Step 22

Fit the right upright to the left upright

Line up the edges of the right upright **6** and the left upright **5** and join them together using 3 screws **I**.

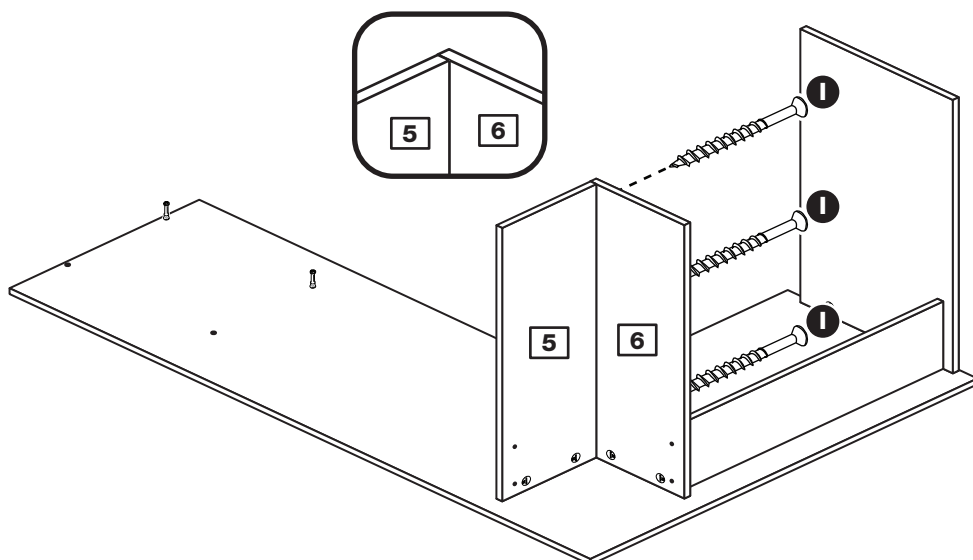

Step 23

Fit the large modesty to the left upright

Attach the large modesty **8** to the right upright **5** using 2 screws **G**.

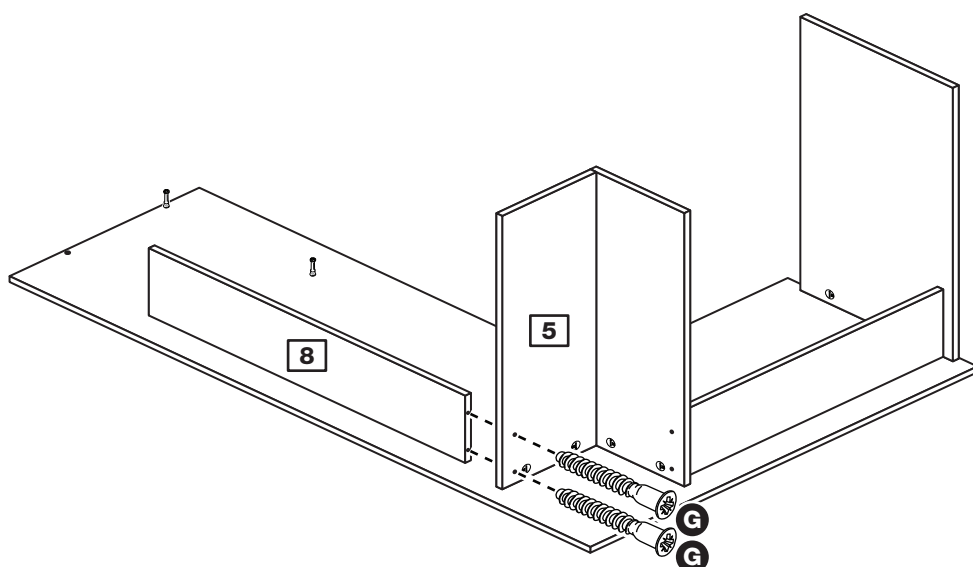

Assembly Instructions

Step 24

Prepare the filer right side

a: Place 2 runners **P** on the filer right side **4** as shown. Slide back the top of runner and use the 2nd hole from the front to fit the 1st screw **N**.

b: Slide the runner **P** back the other way and fit the 2nd screw **N** into the corresponding hole in the filer right side **4**.

c: Fit runner **R a** to the filer right side **4**.

The 1st screw **K** uses the 2nd hole in from the front of the runner.

The 2nd and 3rd screws **K** use the holes that line up with the other panel holes.

d: Fit a screw **L** into the 2nd hole in at the top of the runner **R a**.

Insert a large locking nut **E** into the filer right side **4**.

Tap a wooden dowel **A** into the filer right side **4**.

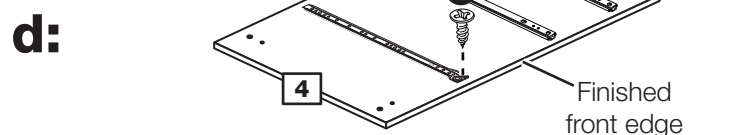
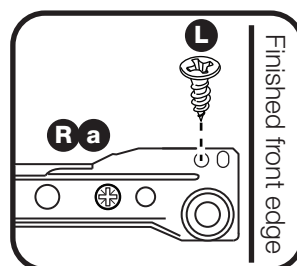
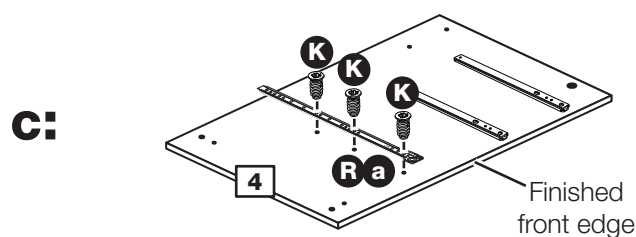
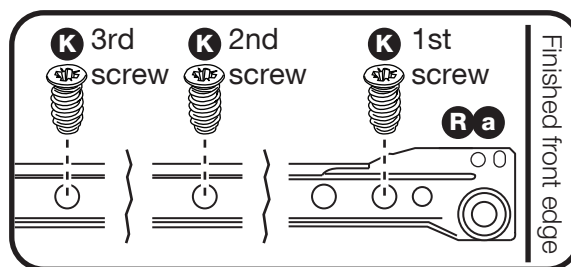
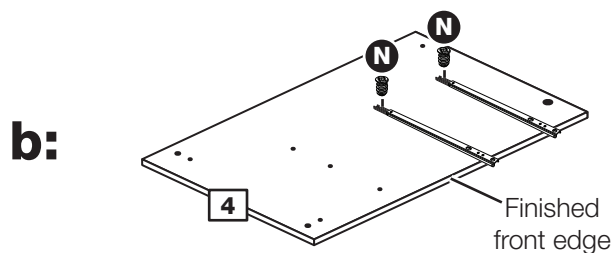
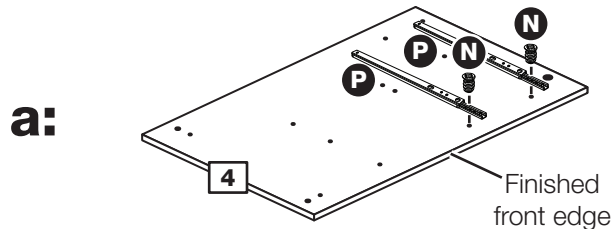
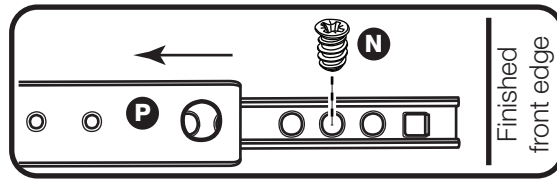

Assembly Instructions

Step 25

Fit the right filer to the desktop

Push the filer right side **4** down onto the desktop **1**.

Use a screwdriver to tighten the large locking nut **E** fitted to the filer right side **4**.

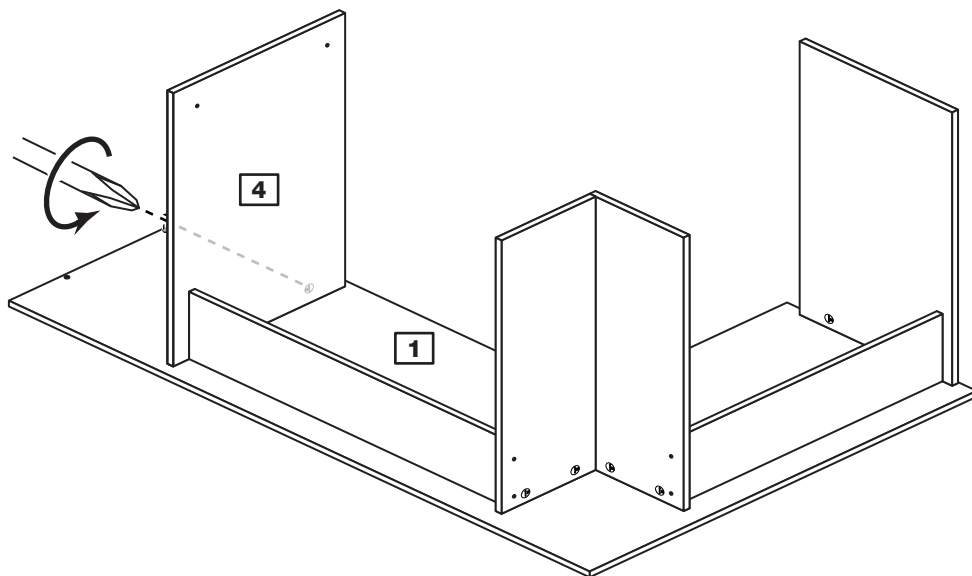

Step 26

Fit the filer right side to the large modesty

Attach the filer right side **4** to the large modesty **8** using 2 screws **G**.

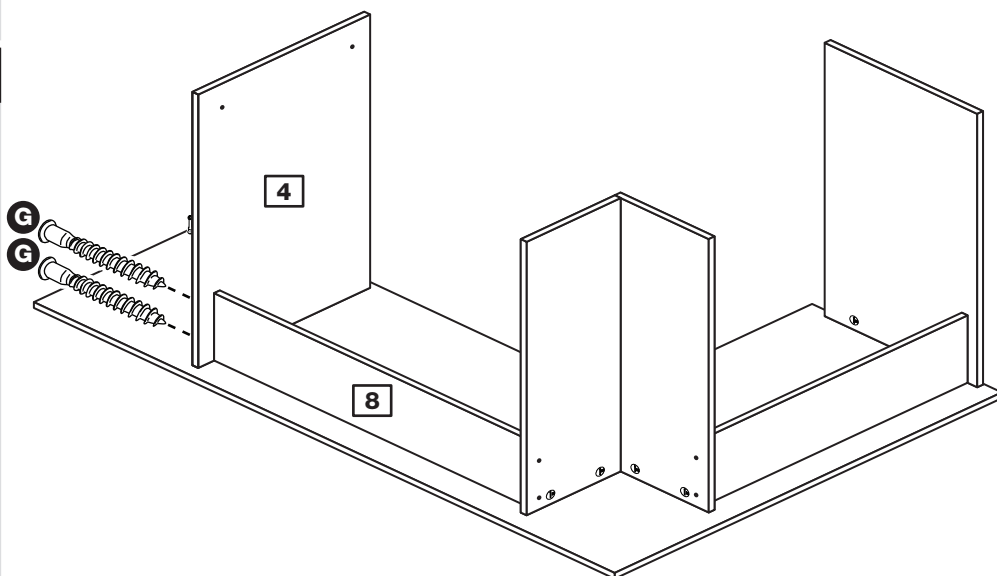

Step 27

Prepare the 2 rails

Tap 2 wooden dowels **A** into each of the rails **9**.

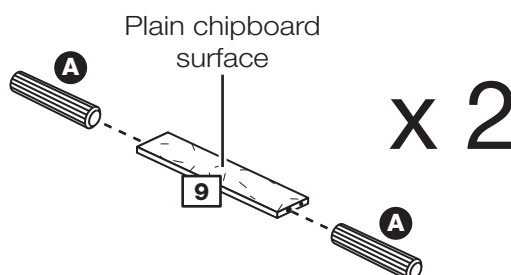

Assembly Instructions

Step 28

Prepare the filer left side

a: Place 2 runners **P** on the filer left side **3** as shown. Slide back the top of runner and use the 2nd hole from the front to fit the 1st screw **N**.

b: Slide the runner **P** back the other way and fit the 2nd screw **N** into the corresponding hole in the filer left side **3**.

c: Fit runner **Rb** to the filer left side **3**.

The 1st screw **K** uses the 2nd hole in from the front of the runner.

The 2nd and 3rd screws **K** use the holes that line up with the other panel holes.

d: Fit a screw **L** into the 2nd hole in at the top of the runner **Rb**.

Insert a large locking nut **E** into the filer left side **3**.

Tap a wooden dowel **A** into the filer left side **3**.

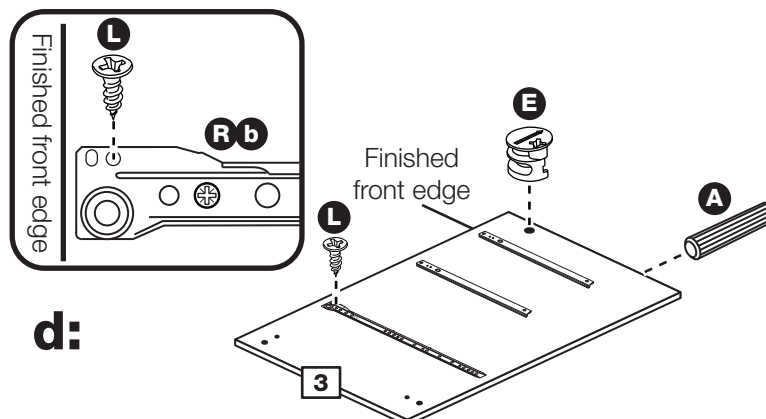
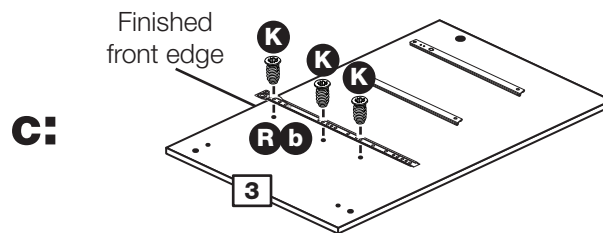
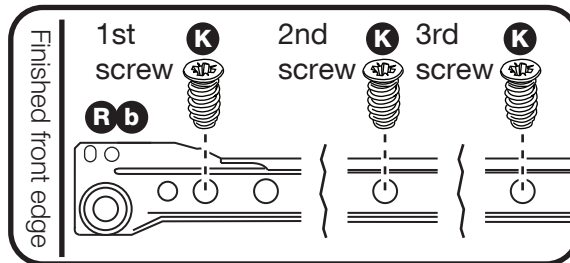
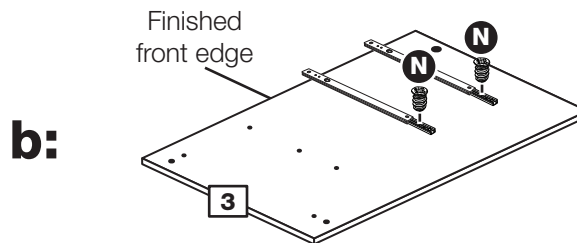
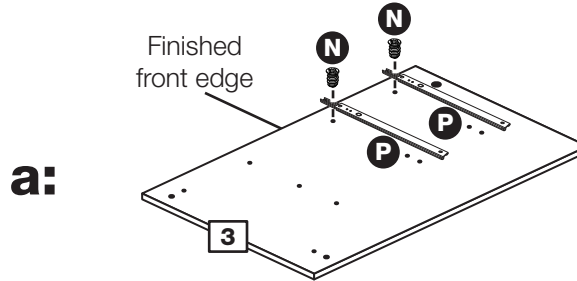
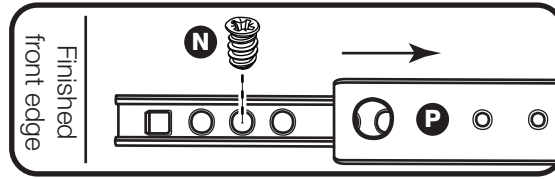

Assembly Instructions

Step 29

Fit the 2 rails to the filer right side

Attach the 2 rails **9** to the filer right side **4** using 2 screws **G**.

Note: Support the 2 rails until the filer left side has been fitted in the next step.

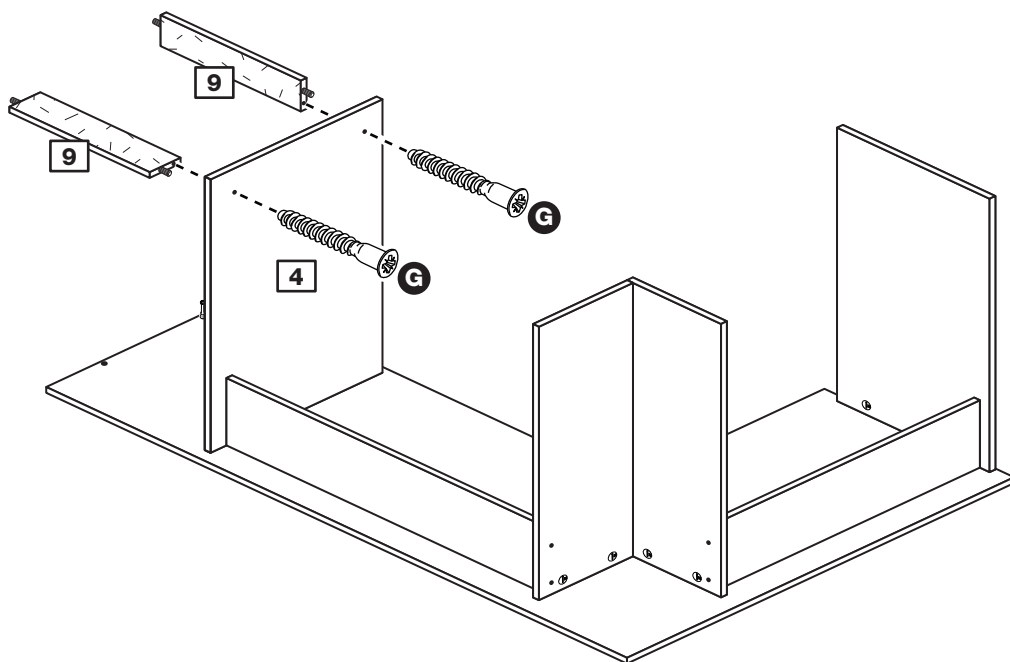

Step 30

Fit the filer left side to the desktop

Push the filer left side **3** down onto the desktop **1**.

Use a screwdriver to tighten the large locking nut **E** fitted to the filer left side **3**.

Attach the filer left side **3** to the 2 rails **9** using 2 screws **G**.

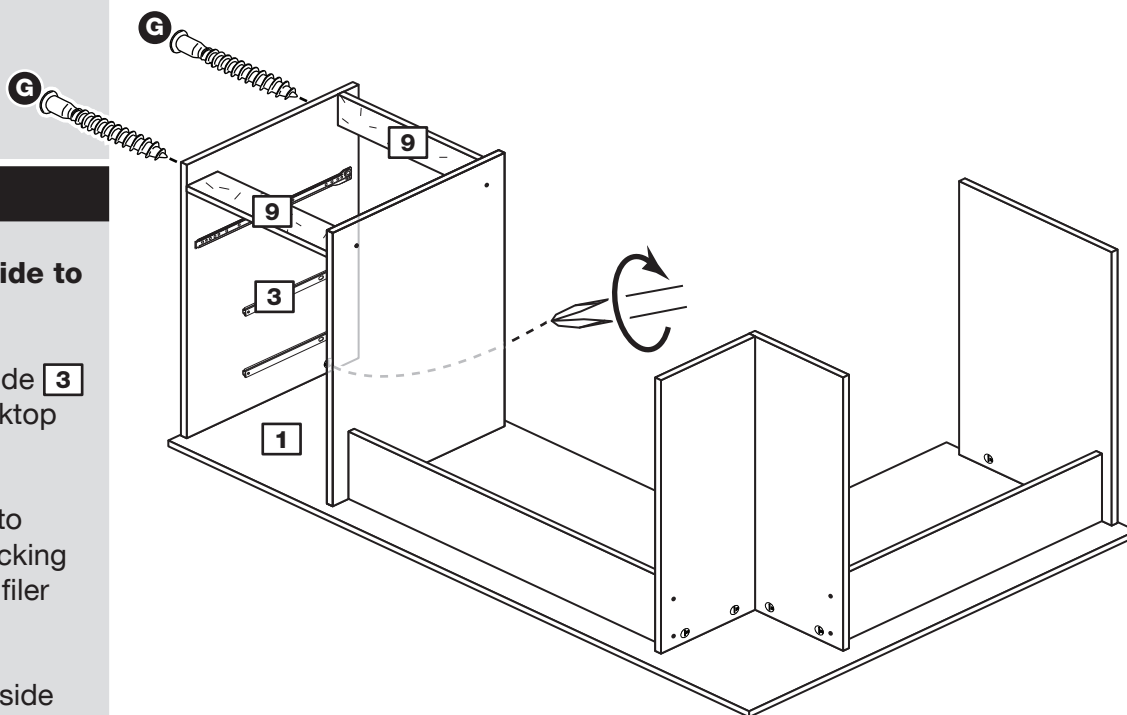

Assembly Instructions

Step 31

Fit the plastic nails

Tap 2 plastic nails **J** into the bottom edge of the right end **2**, filer left side **3**, filer right side **4**, left upright **5** and right upright **6**.

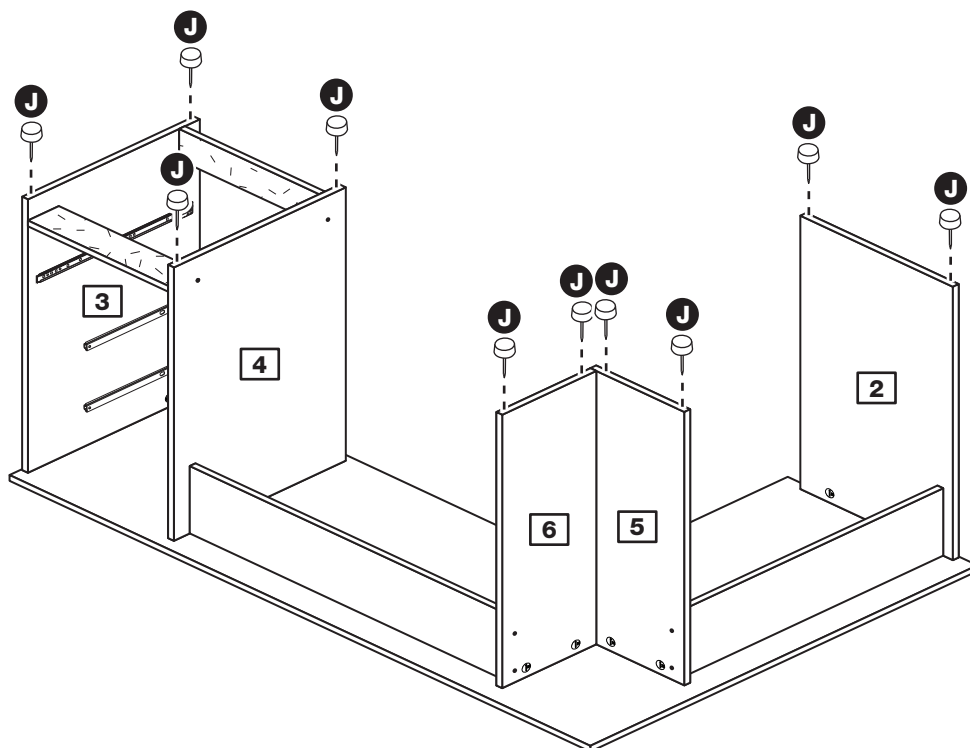

Step 32

Fit the back

a: Square up the filer section of the unit by making sure that measurement **x to x** equals **y to y**.

b: Position the back **18** onto the unit.

Nail **F** around the 3 outside edges of the back **18** as shown.

Note: Nails should be spaced about 150mm apart.

Using at least 2 people, carefully stand the unit up for the next step.

a: The measurement from top corner X to bottom corner X must be equal to the measurement from top corner Y to bottom corner Y

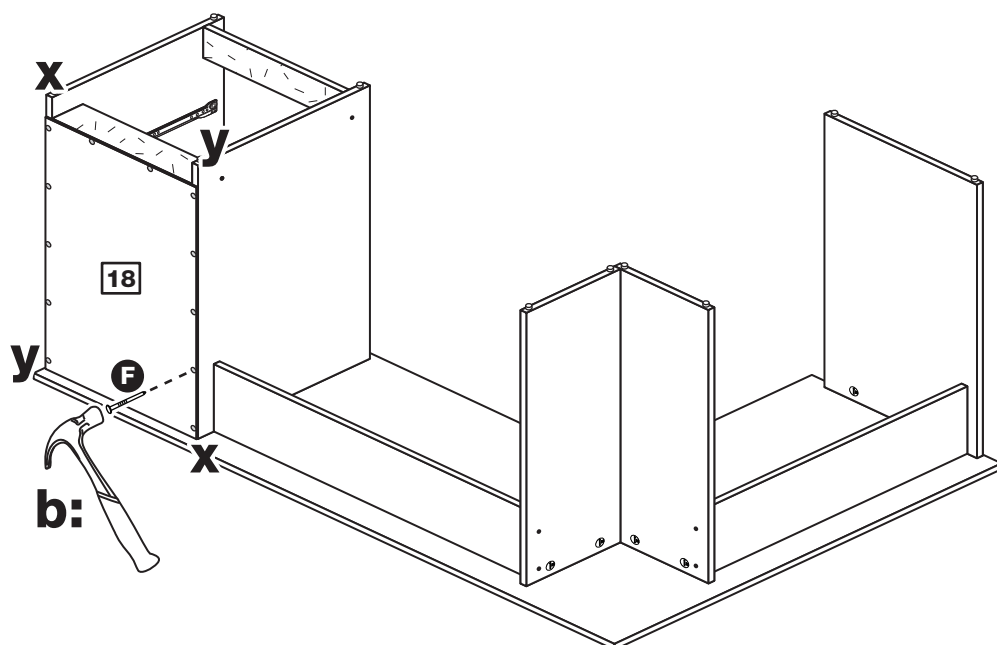

Assembly Instructions

Step 33

Fit the 2 drawers

Starting with the bottom drawer, slide both the runners **P** forward and locate the drawer sides **11** and **12** between them, lining up the holes in the drawer wrap with the 2nd 'threaded' holes in the runners **P**.

Working from the inside of the drawer, insert 2 screws **M** through the drawer sides and out into the 2nd threaded hole in the runner.

Note: Do not overtighten the screws **M**. If they catch on the runner you may need to loosen them slightly.

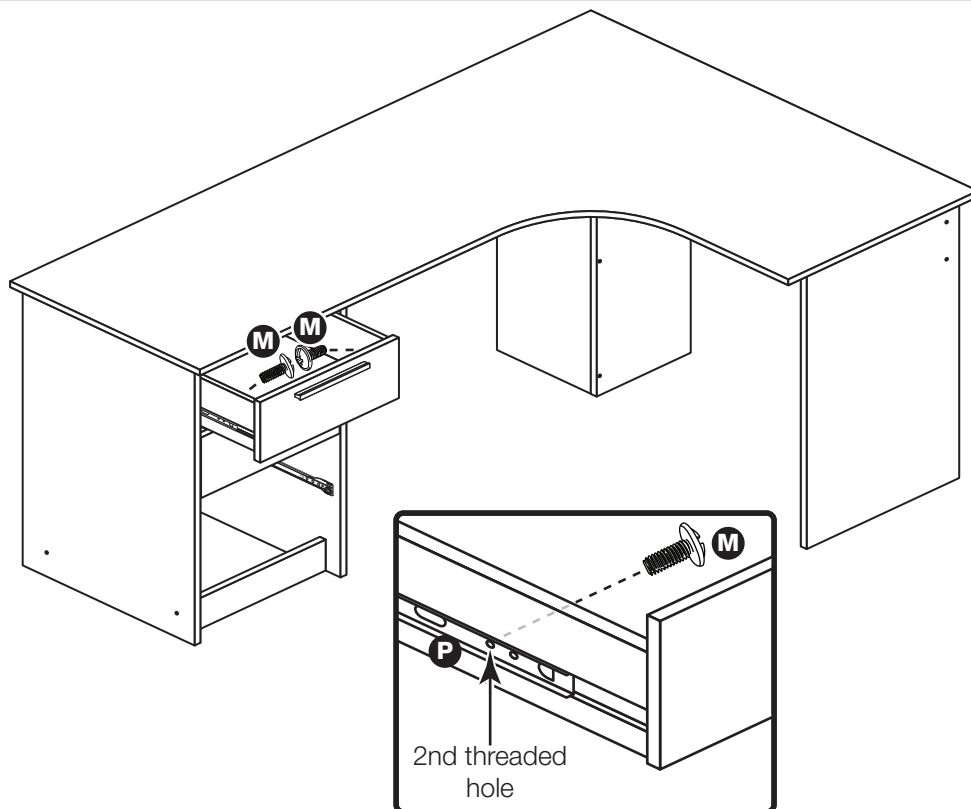

Step 34

Fit the filer drawer

Slide the wheels on the runners fitted to the filer drawer over the wheels of the runners fitted to the side panels and push the drawer into position.

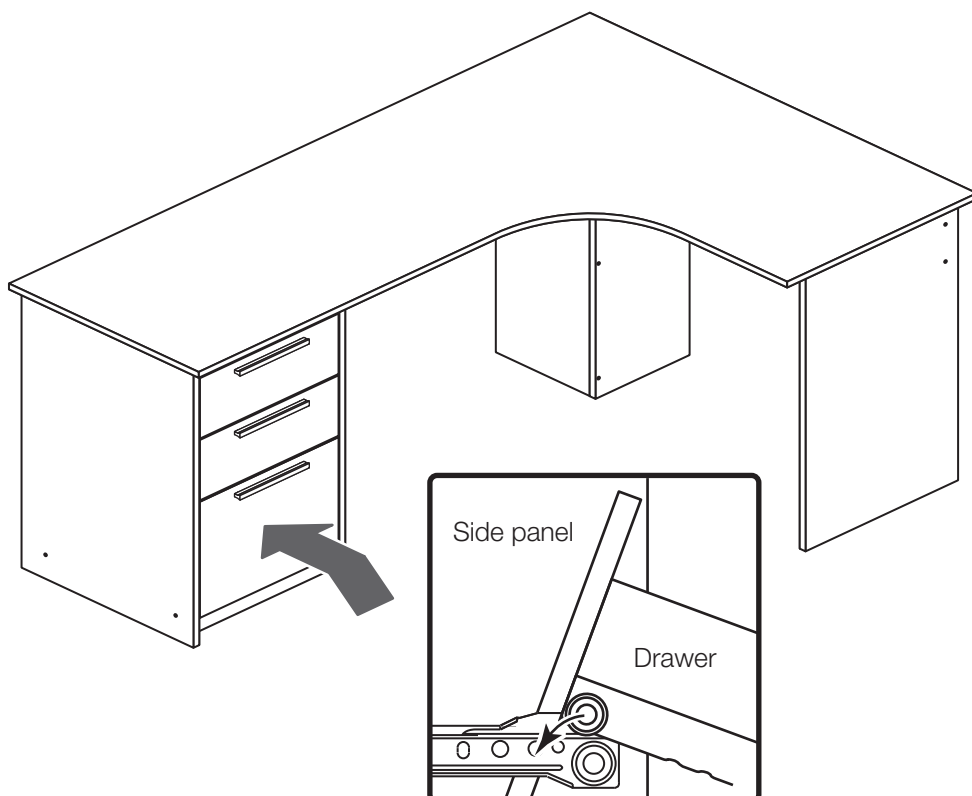

Assembly Instructions

Step 35

Assembly is complete

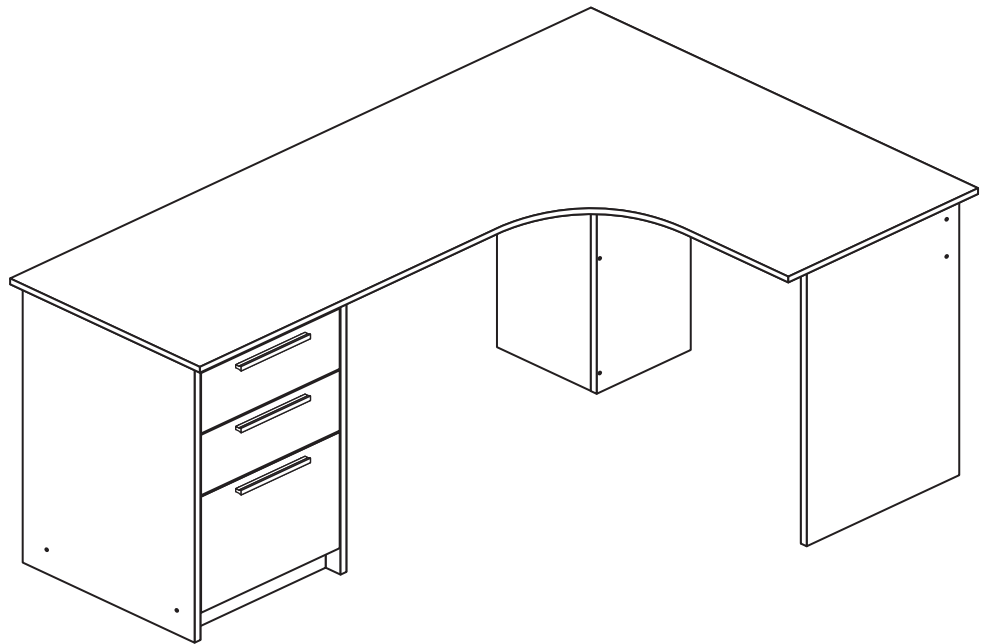

If you need help or have damaged or missing parts, call the **Customer Helpline: 08456 400800** and quote the reference numbers on the component pages.
Argos Ltd, 489-499 Avebury Boulevard, Central Milton Keynes, MK9 2NW

Large Shaped Corner Desk

Assembly Instructions - Please keep for future reference

213/4864

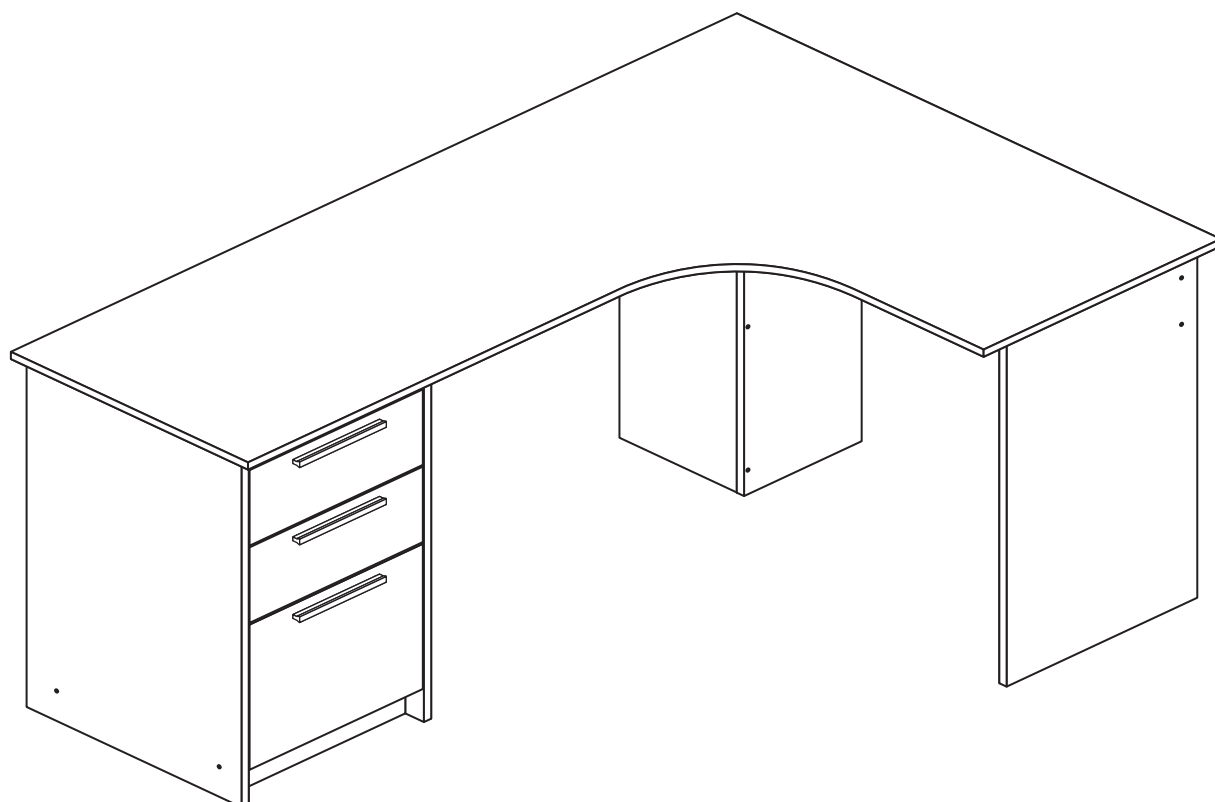

Dimensions

Width - 150cm

Depth - 100cm

Height - 73cm



**MADE IN
BRITAIN**

Important - Please read these instructions fully before starting assembly

If you need help or have damaged or missing parts, call the **Customer Helpline: 03456 400800**



Safety and Care Advice

Important - Please read these instructions fully before starting assembly

- **Warning:** This unit weighs approximately 36kgs. Please lift with care.

- Check you have all the components and tools listed on pages 2 and 3.

- Remove all fittings from the plastic bags and separate them into their groups.

- Keep children and animals away from the work area, small parts could choke if swallowed.

- Parts of the assembly will be easier with 2 people.

- Make sure you have enough space to layout the parts before starting.

- Do not stand or put weight on the product, this could cause damage.

- Assemble the item as close to its final position (in the same room) as possible.

- Assemble on a soft level surface to avoid damaging the unit or your floor (use opened out unit carton).



- We do not recommend the use of power drill/drivers **for inserting screws**, as this could damage the unit. Only use hand screwdrivers.

- **Safety note:** If there is any chance of this unit being pulled over by children etc. it is recommended that the unit is secured to a wall using suitable fixings (not supplied).

- Dispose of all packaging carefully and responsibly.

Care and maintenance

- Only clean using a damp cloth and mild detergent, do not use bleach or abrasive cleaners.

- From time to time check that there are no loose screws on this unit.

- This product should not be discarded with household waste. Take to your local authority waste disposal centre.

Tools required

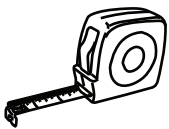

Rule



Cross-head screwdriver



Scissors



Hammer



Eye protection (when using a hammer or drill)

Note: If required the next page can be cut out and used as reference throughout the assembly. Keep this page with these instructions for future reference.

Components - Panels

If you have damaged or missing components, call the **Customer Helpline: 03456 400800** quoting the reference numbers below

Please check you have all the panels listed below

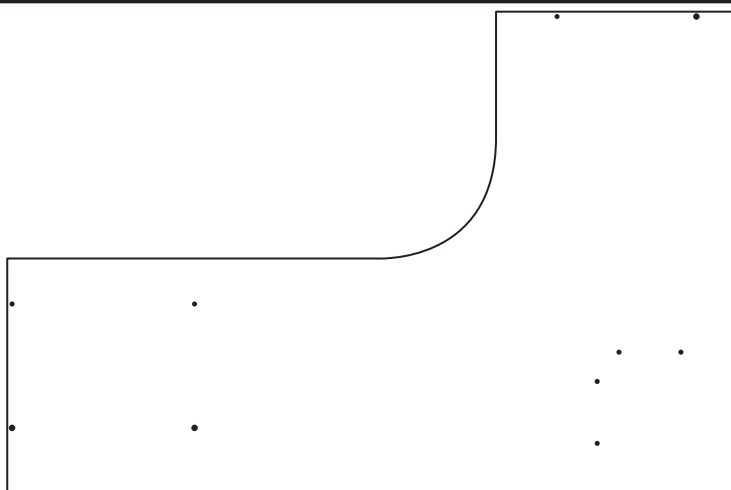

1 Desktop (DF729)
(1500 x 1000mm)



2 Right End (DF730)
(706 x 394mm)

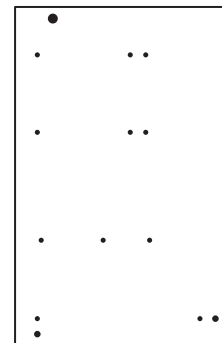

3 Filer Left Side (DF958)
(706 x 444mm)

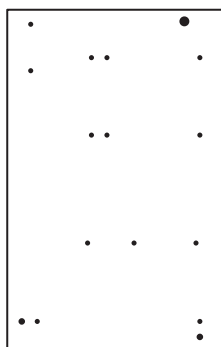

4 Filer Right Side (DF942)
(706 x 444mm)



5 Left Upright (DF731)
(706 x 243mm)

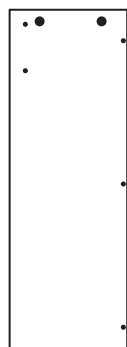

6 Right Upright (DF732)
(706 x 243mm)



7 Small Modesty (DF733)
(678.5 x 174mm)



8 Large Modesty (DF811)
(817 x 174mm)

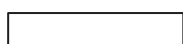

9 Rail (D0858A)
(362 x 80mm) x 2

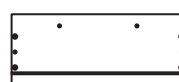

10 Drawer Front (DF944)
(358 x 156mm) x 2



11 Left Drawer Side (W370-124LH)
(370 x 124mm) x 2



12 Right Drawer Side (W370-124RH)
(370 x 124mm) x 2



13 Drawer Back (W331-124LH)
(331 x 124mm) x 2

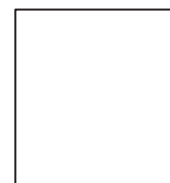

14 Drawer Base (T342-367)
(342 x 367mm) x 2

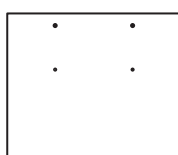

15 File Front (DF943)
(358 x 300mm)

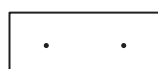

16 File Wrap (FW312-124)
(312 x 124mm) x 2

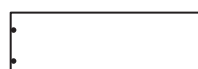

17 File Side (FW400-124)
(400 x 124mm) x 2



18 Back (X807)
(390 x 650mm)











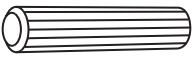
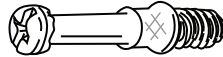



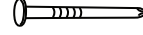



Components - Fittings

If you have damaged or missing components, call the **Customer Helpline: 03456 400800** quoting the reference numbers below

Please check you have all the fittings listed below

Note: The quantities below are the correct amount to complete the assembly. In some cases more fittings may be supplied than are required.

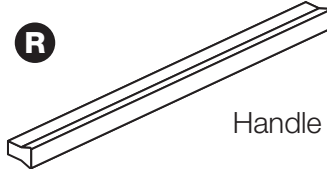
<p>A </p> <p>Wooden dowel (F22) x 7</p>	<p>B </p> <p>Metal dowel (F901) x 11</p>	<p>C </p> <p>Knock-in Peg (F171GY) x 16</p>	
<p>D </p> <p>Small locking nut (F3) x 4</p>	<p>E </p> <p>Large locking nut (F900) x 7</p>	<p>F </p> <p>Nail (F51) x 14</p>	
<p>G </p> <p>40mm Screw (F910) x 12</p>	<p>H </p> <p>25mm Screw (F50) x 2</p>	<p>I </p> <p>45mm Screw (F65) x 3</p>	
<p>J </p> <p>25mm Screw (F95) x 6</p>	<p>K </p> <p>13mm Screw (F52) x 6</p>	<p>L </p> <p>13mm Screw (F63) x 6</p>	
<p>M </p> <p>9mm Screw (F74) x 4</p>	<p>N </p> <p>9mm Screw (F73) x 8</p>	<p>O </p> <p>Wedgex (F639) x 4</p>	<p>P </p> <p>Plastic Nail (F91) x 10</p>
<p>Q </p> <p>Drawer runner (F1004) x 4</p>		<p>R </p> <p>Handle (F262) x 3</p>	

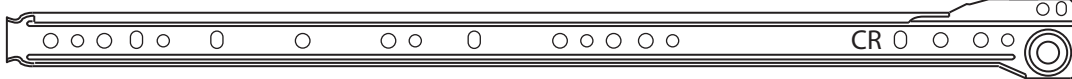
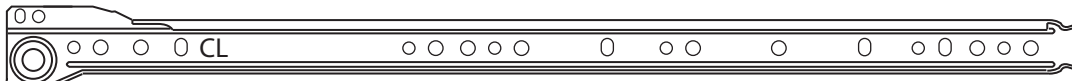
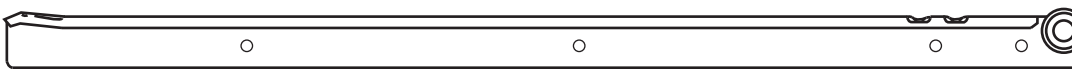
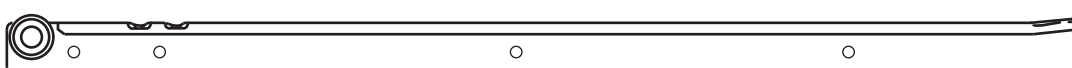
<p>S a </p>	<p>CR Runner (F903) x 1</p>
<p>S b </p>	<p>CL Runner (F904) x 1</p>
<p>S c </p>	<p>DR Runner (F905) x 1</p>
<p>S d </p>	<p>DL Runner (F906) x 1</p>

Ruler - Use this ruler to help correctly identify the screws

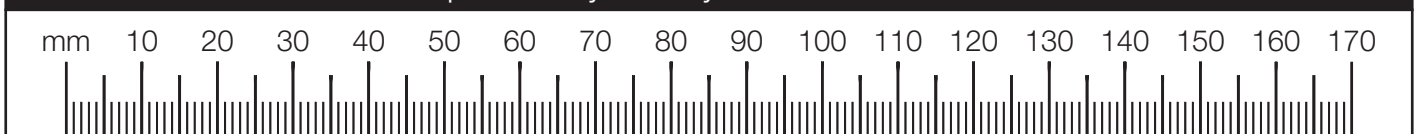

Assembly Instructions

If you have damaged or missing components, call the
Customer Helpline: 03456 400800 quoting the reference
numbers below

Step 1

Prepare the 2 drawer fronts

Screw 2 metal dowels **B** into each of the drawer fronts **10**.

Note: Tighten the metal dowels up fully against the panels.

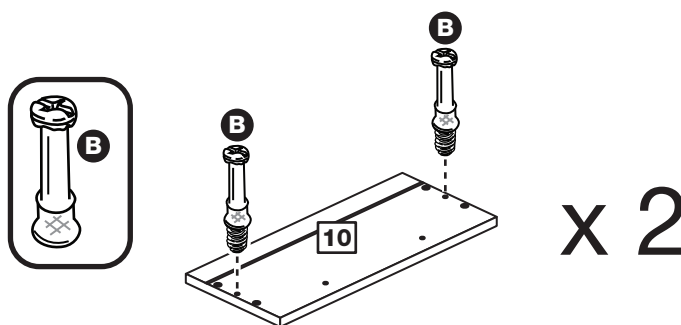

Step 2

Prepare the drawer sides

Insert a small locking nut **D** into the hole shown on the left drawer side **11** and the right drawer side **12**.

Note: The arrow on the locking nut **must** point towards the hole in the edge of the panel.

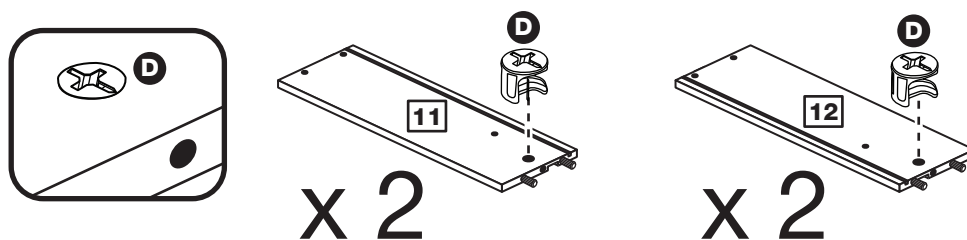

Step 3

Attach the drawer sides to the drawer fronts

Push the left drawer sides **11** and right drawer sides **12** onto the back of the drawer fronts **10**.

Turn the small locking nuts **D** on the left drawer side **11** and right drawer side **12**.

Note: Turn the locking nuts **D** clockwise to secure panels - more than 1/2 a turn.

Note: The locking nuts can be on either surface of the drawer sides. Make sure that the small groove is on the inside, as shown.

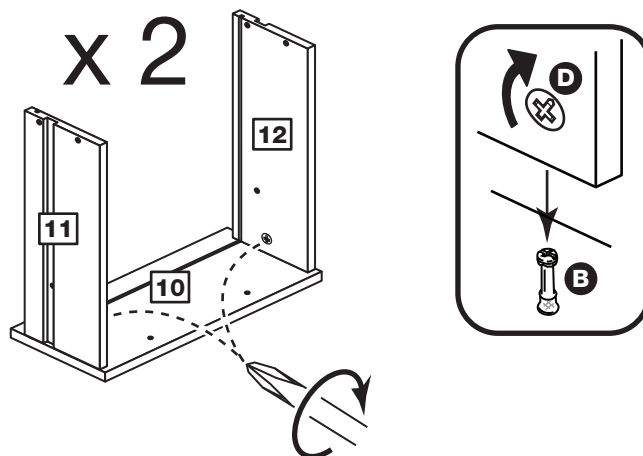

Assembly Instructions

Step 4

Fit the drawer base

Slide the drawer base **14** down the grooves in the drawer sides **11** and **12** and down into the groove in the drawer front **10**.

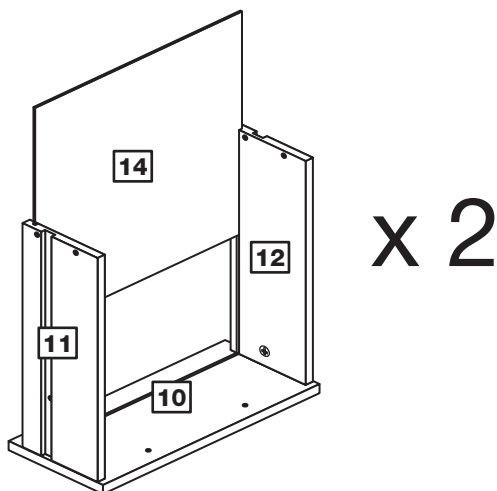

Step 5

Fit the drawer back

Fit the drawer back **13** between the drawer sides **11** and **12**. Make sure that the drawer base **14** fits into the groove in the drawer back **13**.

Hold the drawer back **13** in position and tap the knock-in pegs **C** through the holes in the drawer sides **11** and **12**.

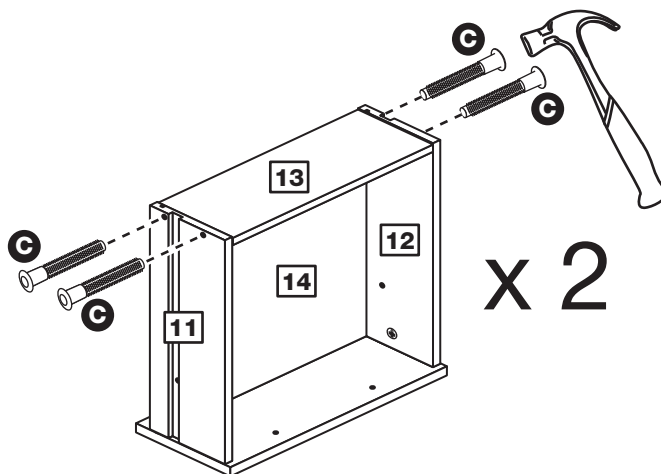

Step 6

Attach the handles

Attach a handle **R** to each of the drawer fronts **10** using screws **J**.

Note: Do not overtighten the screw.

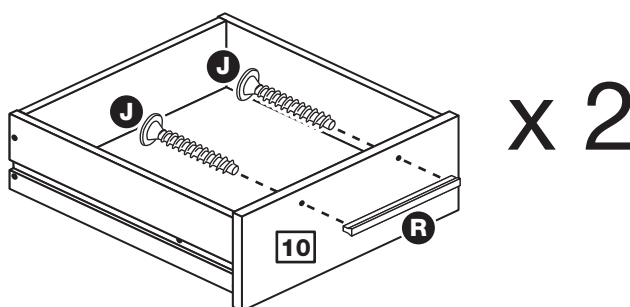

Step 7

Fit the wedgifixes

Turn the drawer assemblies over and slide 2 wedgifixes **O** into the front and back grooves, as shown, and tighten up the screws.

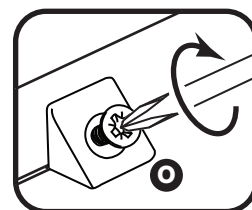
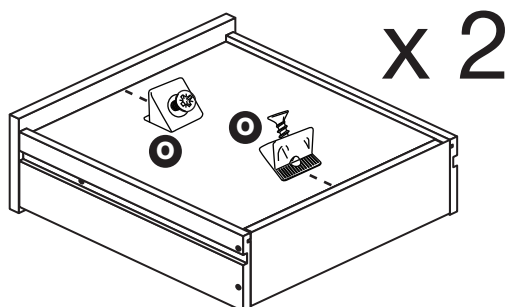

Assembly Instructions

Step 8

Fit a file side to the file wraps

Position a file side **17** onto 2 file wraps **16**, as shown.

Tap 4 knock-in pegs **C** through the holes in the file side **17** and into the file wraps **16**.

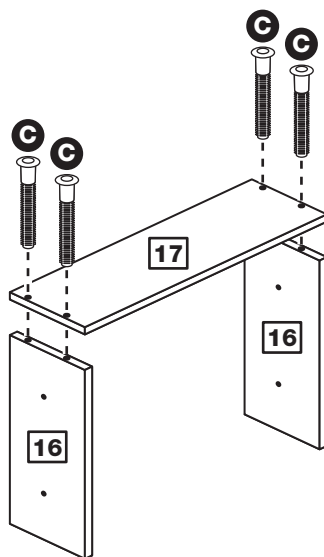

Step 9

Fit the other file side to the file wraps

Position the file side **17** onto 2 file wraps **16**, as shown.

Tap 4 knock-in pegs **C** through the holes in the file side **17** and into the file wraps **16**.

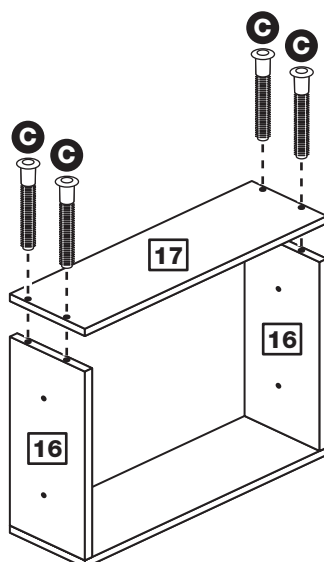

Step 10

Fit the file front

Fit the file front **15** to one of the file wraps **16** by screwing into the shallow mark holes on the back surface of the file front **15** using 2 screws **H**.

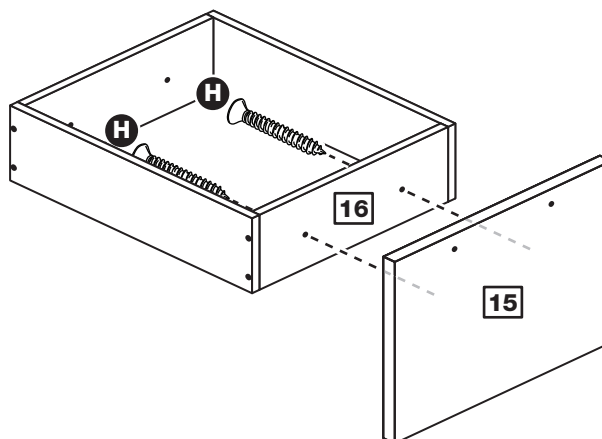

Assembly Instructions

Step 11

Attach the handles

Attach a handle **R** to the file front **15** using screws **J**.

Note: Do not overtighten the screw.

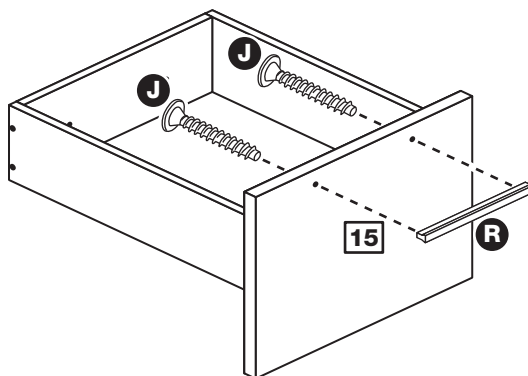

Step 12

Fit the runners to the file sides

Turn the file drawer assembly over.

Fit runner **Sc**, marked with 'DR', to the bottom edge of the right file side **17** as shown, making sure that it is pushed up against the back of the file front **15**. Use a bradawl to mark the fixing positions, then secure with 2 screws **L**.

Fit runner **Sd**, marked 'DL', to the bottom edge of the left file side using the same method.

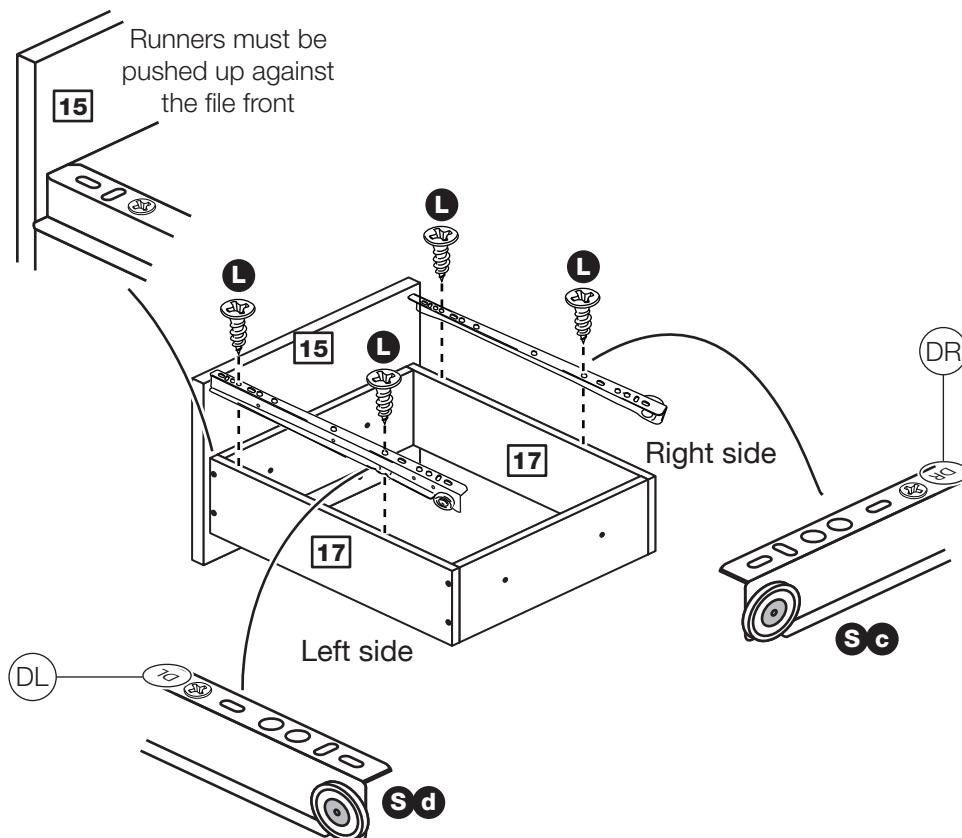

Assembly Instructions

Step 13

Prepare the desktop

Screw 7 metal dowels **B** into the desktop **1**.

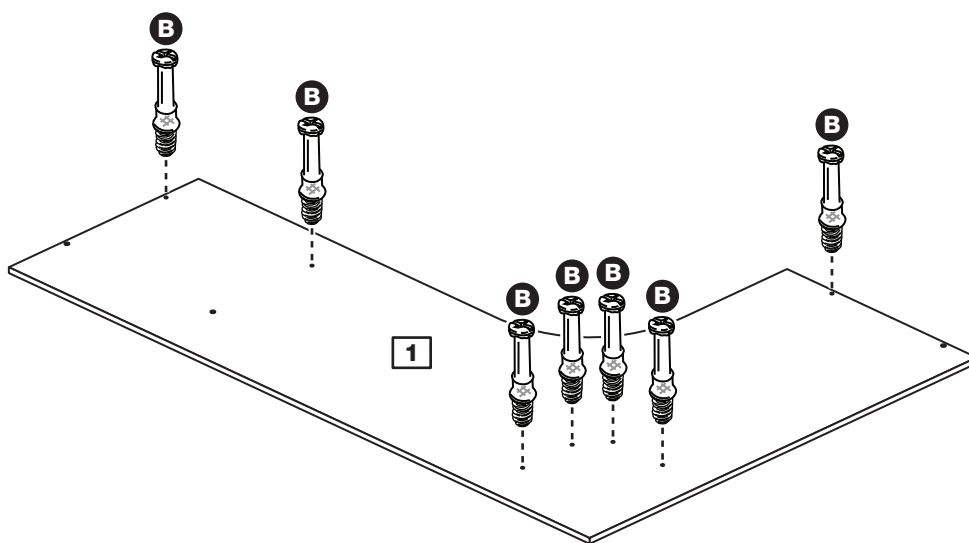

Step 14

Prepare the right end

Insert a large locking nut **E** into the right end **2**.

Note: The arrow on the locking nut **must** point towards the hole in the edge of the panel.

Tap a wooden dowel **A** into the right end **2**.

Note: Wooden dowels **must not** stick out from the edge by more than 10mm or they may damage other panels.

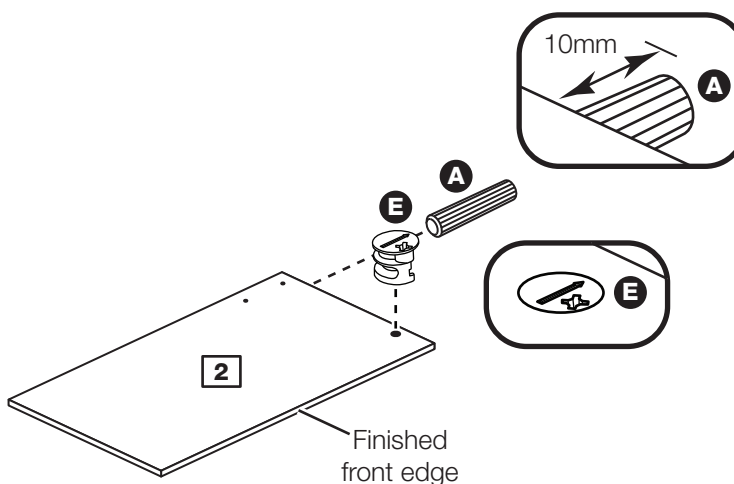

Assembly Instructions

Step 15

Fit the right end to the desktop

Push the right end **2** down onto the desktop **1**.

Use a screwdriver to tighten the large locking nut **E** fitted to the right end **2**.

Note: Turn the large locking nuts **E** as far as they will go - more than 1/2 a turn.

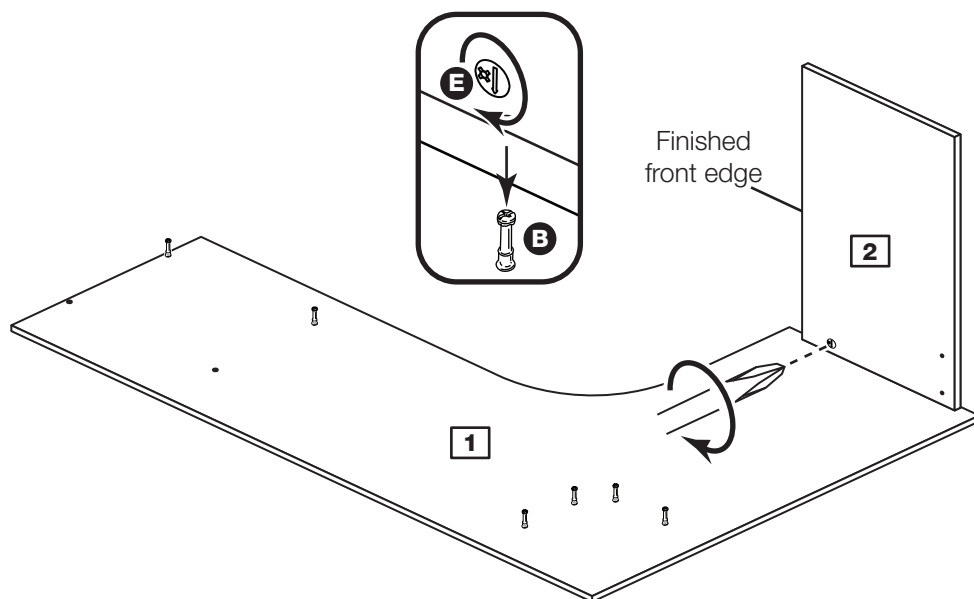

Step 16

Fit the small modesty to the right end

Attach the small modesty **7** to the right end **2** using 2 screws **G**.

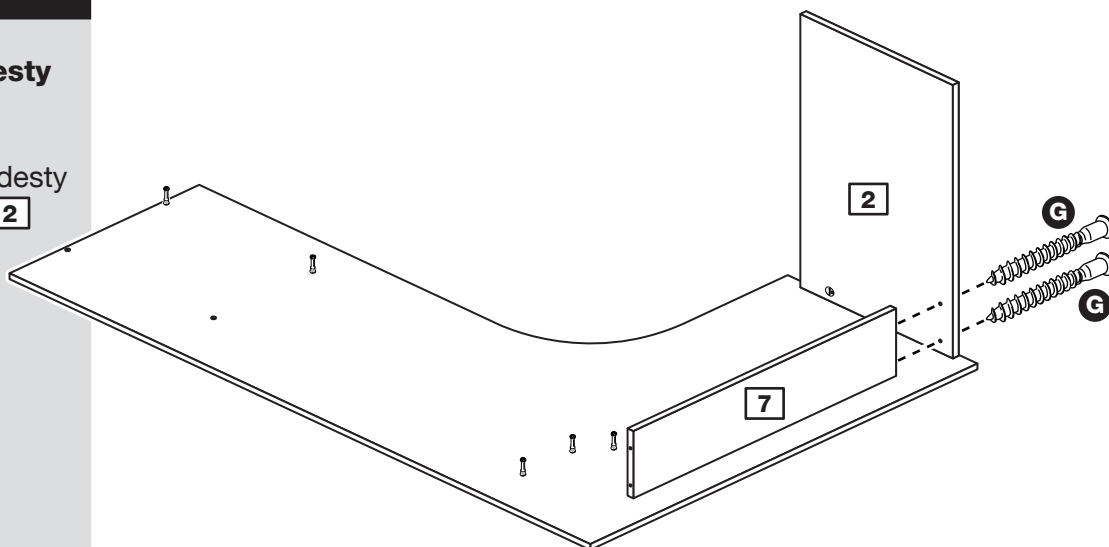

Step 17

Prepare the right upright

Insert 2 large locking nuts **E** into the right upright **6**.

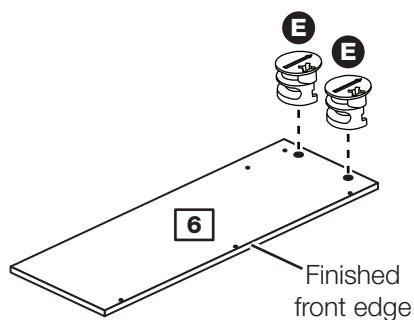

Assembly Instructions

Step 18

Fit the right upright to the desktop

Push the right upright **6** down onto the desktop **1**.

Use a screwdriver to tighten the 2 large locking nuts **E** fitted to the right upright **6**.

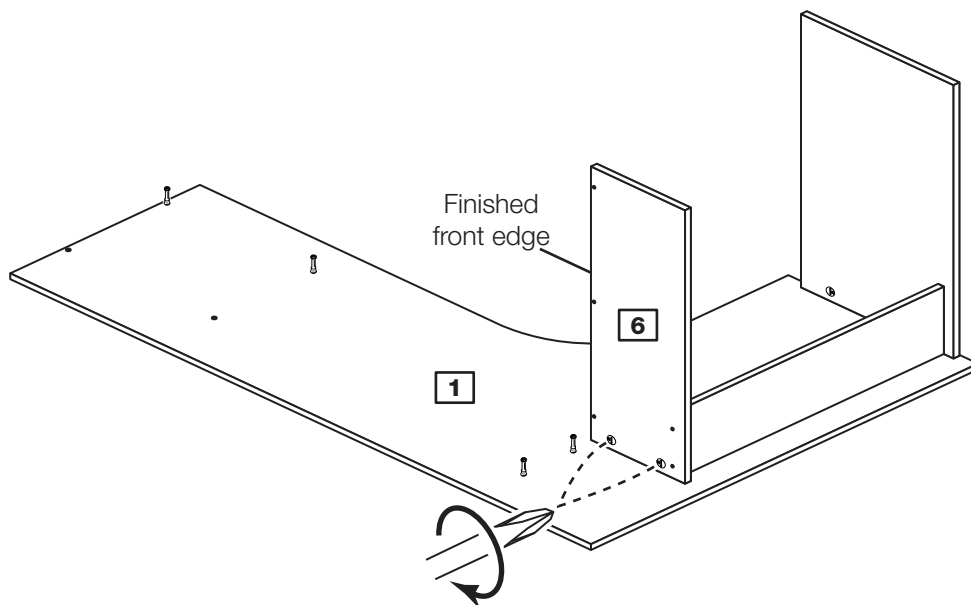

Step 19

Fit the right upright to the small modesty

Attach the right upright **6** to the small modesty **7** using 2 screws **G**.

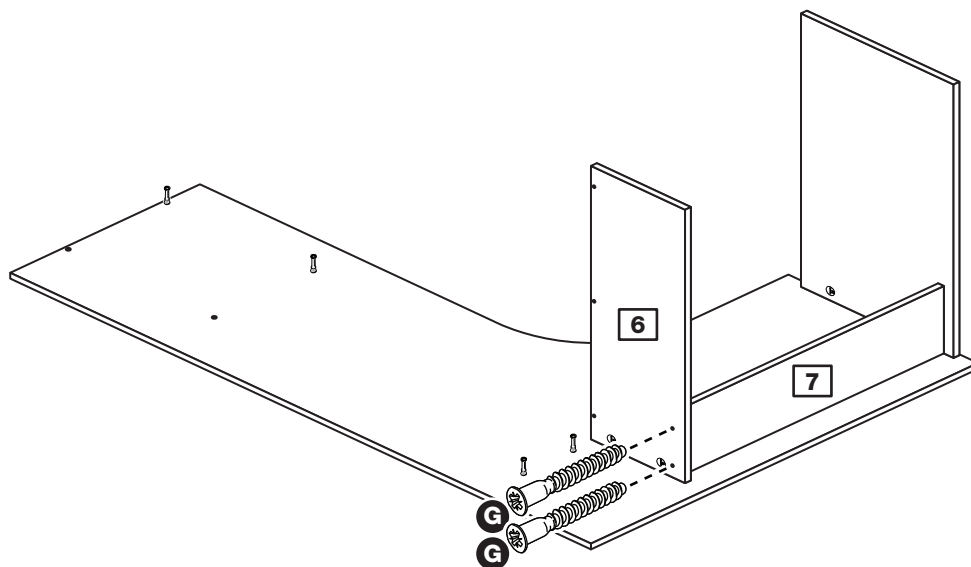

Step 20

Prepare the left upright

Insert 2 large locking nuts **E** into the left upright **5**.

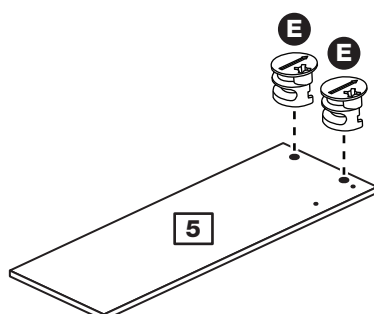

Assembly Instructions

Step 21

Fit the left upright to the desktop

Push the left upright **5** down onto the desktop **1**.

Use a screwdriver to tighten the 2 large locking nuts **E** fitted to the left upright **5**.

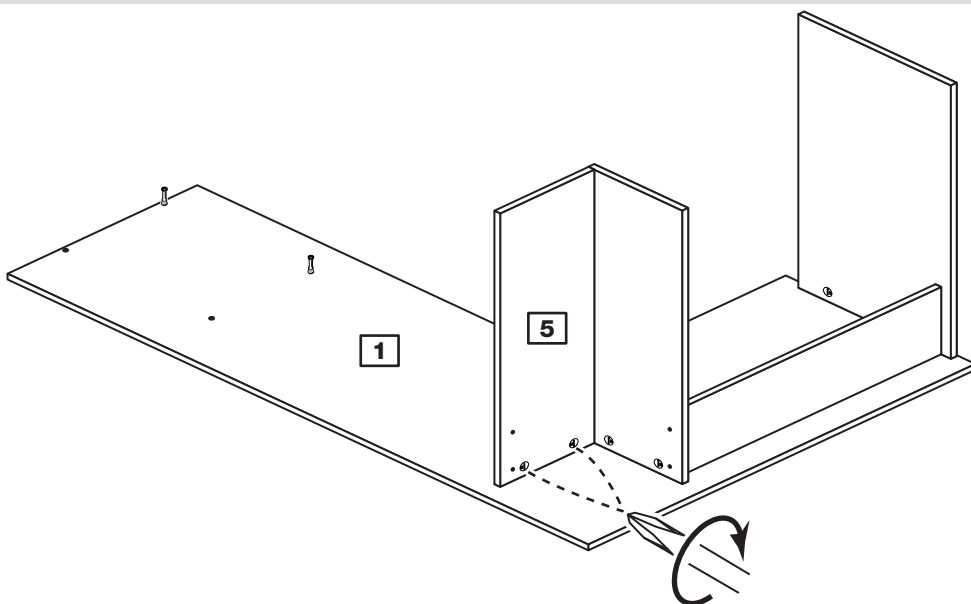

Step 22

Fit the right upright to the left upright

Line up the edges of the right upright **6** and the left upright **5** and join them together using 3 screws **I**.

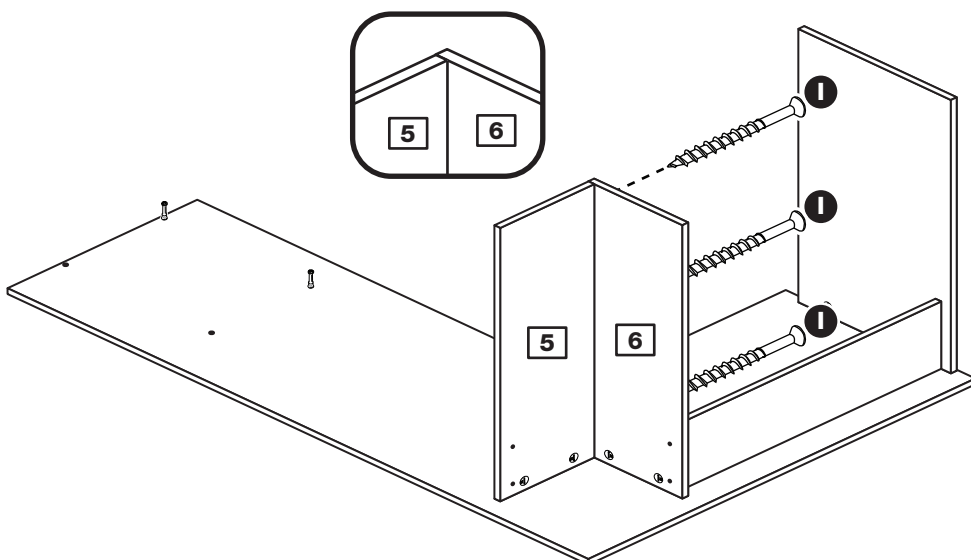

Step 23

Fit the large modesty to the left upright

Attach the large modesty **8** to the right upright **5** using 2 screws **G**.

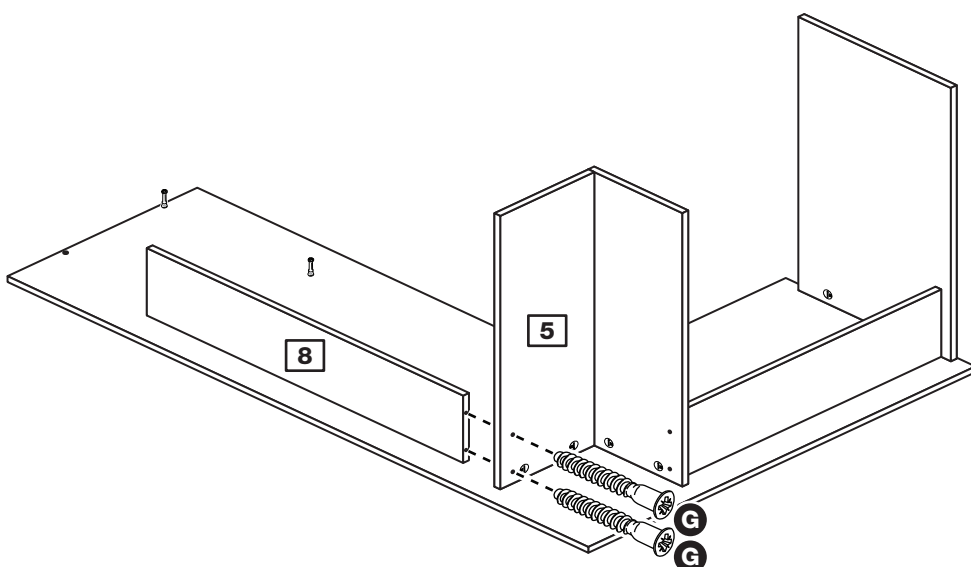

Assembly Instructions

Step 24

Prepare the filer right side

a: Place 2 runners **Q** on the filer right side **4** as shown. Slide back the top of runner and use the 2nd hole from the front to fit the 1st screw **N**.

b: Slide the runner **Q** back the other way and fit the 2nd screw **N** into the corresponding hole in the filer right side **4**.

c: Fit runner **Sa** to the filer right side **4**.

The 1st screw **K** uses the 2nd hole in from the front of the runner.

The 2nd and 3rd screws **K** use the holes that line up with the other panel holes.

d: Fit a screw **L** into the 2nd hole in at the top of the runner **Sa**.

Insert a large locking nut **E** into the filer right side **4**.

Tap a wooden dowel **A** into the filer right side **4**.

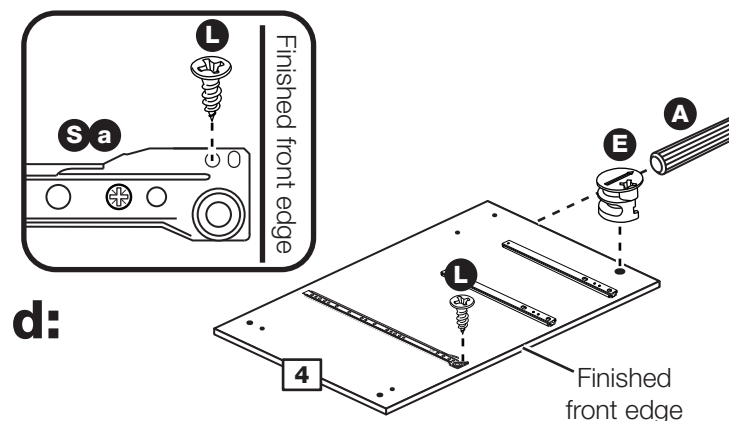
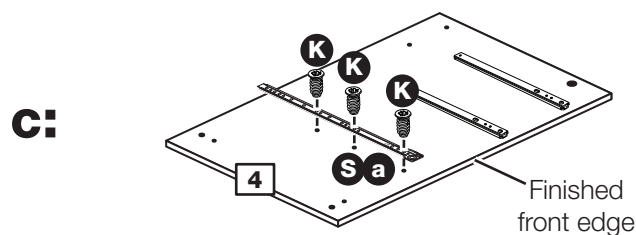
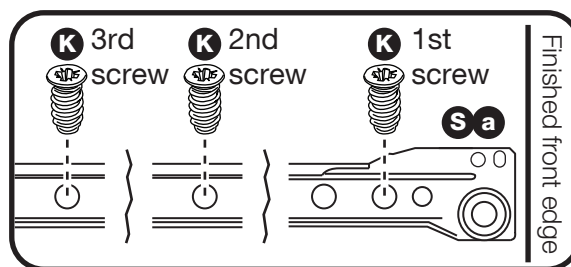
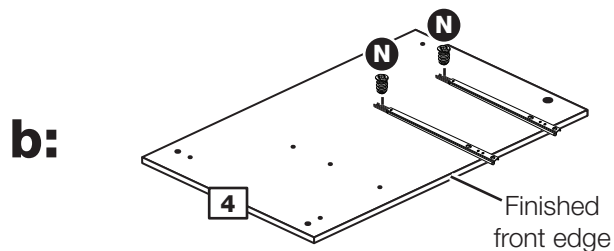
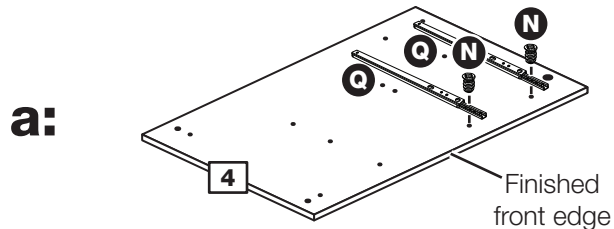
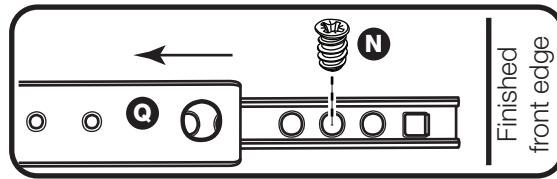

Assembly Instructions

Step 25

Fit the right filer to the desktop

Push the filer right side **4** down onto the desktop **1**.

Use a screwdriver to tighten the large locking nut **E** fitted to the filer right side **4**.

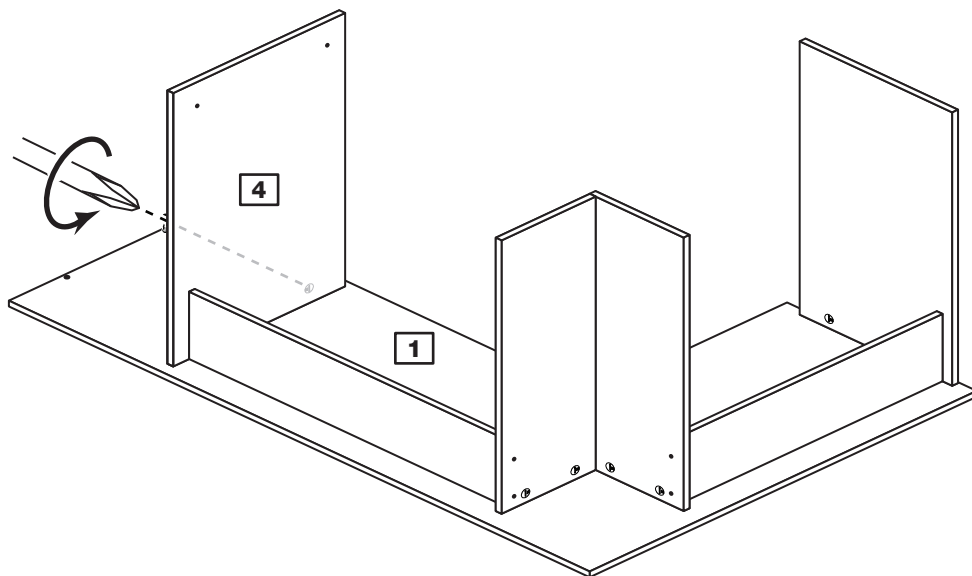

Step 26

Fit the filer right side to the large modesty

Attach the filer right side **4** to the large modesty **8** using 2 screws **G**.

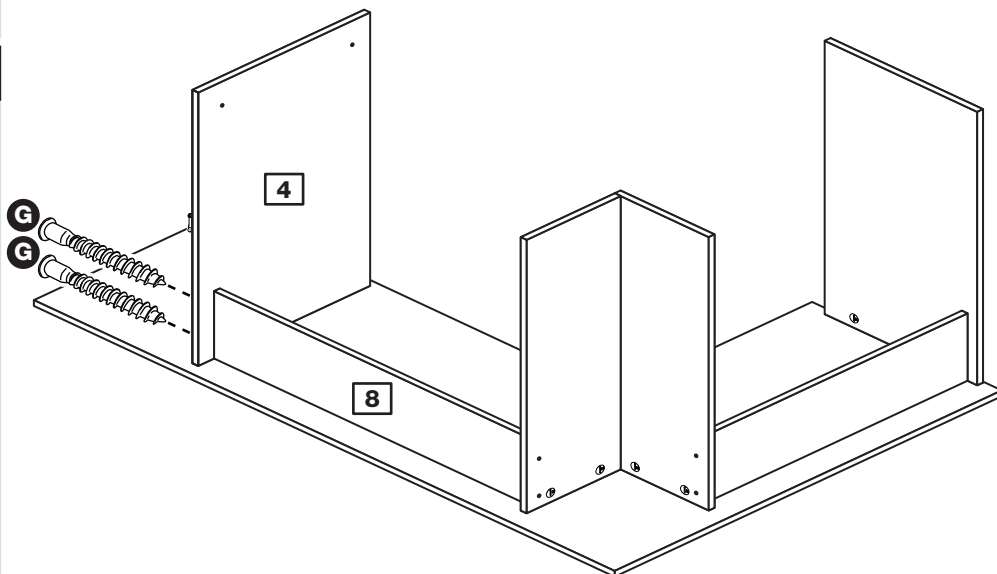

Step 27

Prepare the 2 rails

Tap 2 wooden dowels **A** into each of the rails **9**.

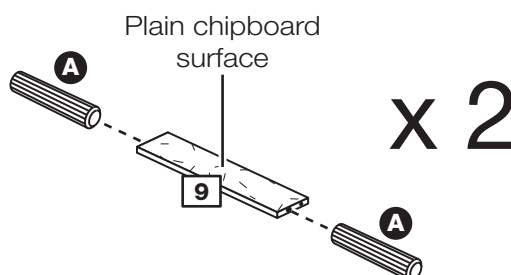

Assembly Instructions

Step 28

Prepare the filer left side

a: Place 2 runners **Q** on the filer left side **3** as shown. Slide back the top of runner and use the 2nd hole from the front to fit the 1st screw **N**.

b: Slide the runner **Q** back the other way and fit the 2nd screw **N** into the corresponding hole in the filer left side **3**.

c: Fit runner **Sb** to the filer left side **3**.

The 1st screw **K** uses the 2nd hole in from the front of the runner.

The 2nd and 3rd screws **K** use the holes that line up with the other panel holes.

d: Fit a screw **L** into the 2nd hole in at the top of the runner **Sb**.

Insert a large locking nut **E** into the filer left side **3**.

Tap a wooden dowel **A** into the filer left side **3**.

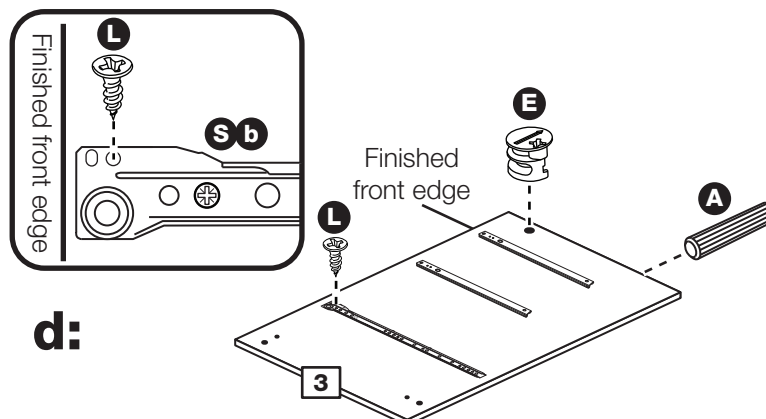
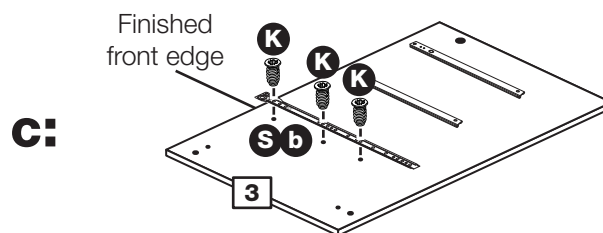
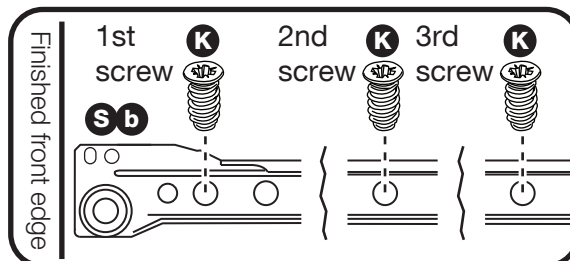
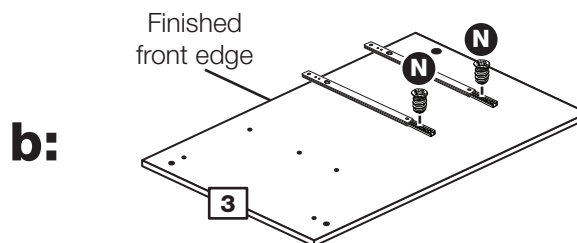
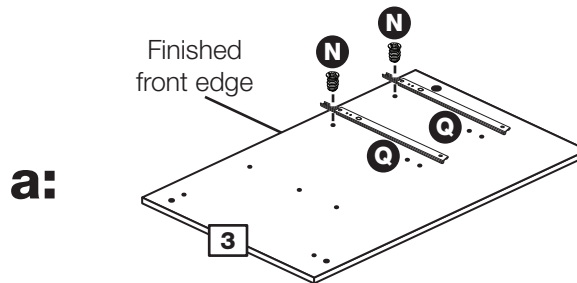
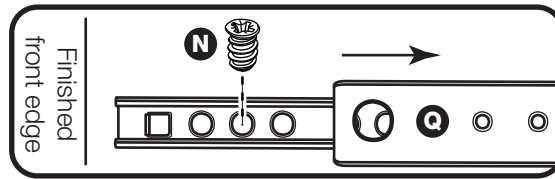

Assembly Instructions

Step 29

Fit the 2 rails to the filer right side

Attach the 2 rails **9** to the filer right side **4** using 2 screws **G**.

Note: Support the 2 rails until the filer left side has been fitted in the next step.

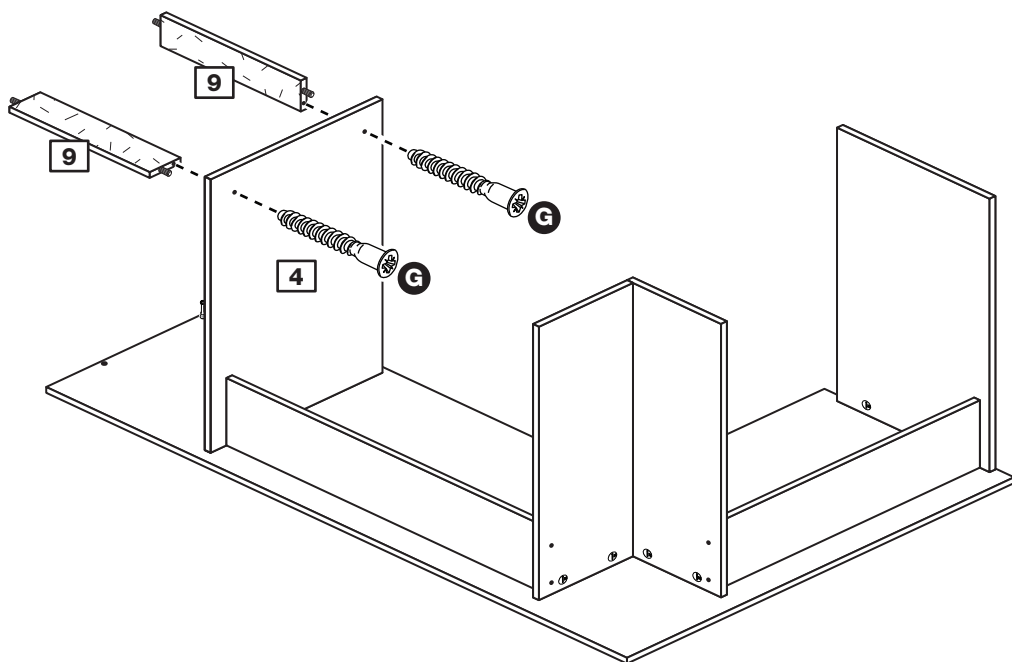

Step 30

Fit the filer left side to the desktop

Push the filer left side **3** down onto the desktop **1**.

Use a screwdriver to tighten the large locking nut **E** fitted to the filer left side **3**.

Attach the filer left side **3** to the 2 rails **9** using 2 screws **G**.

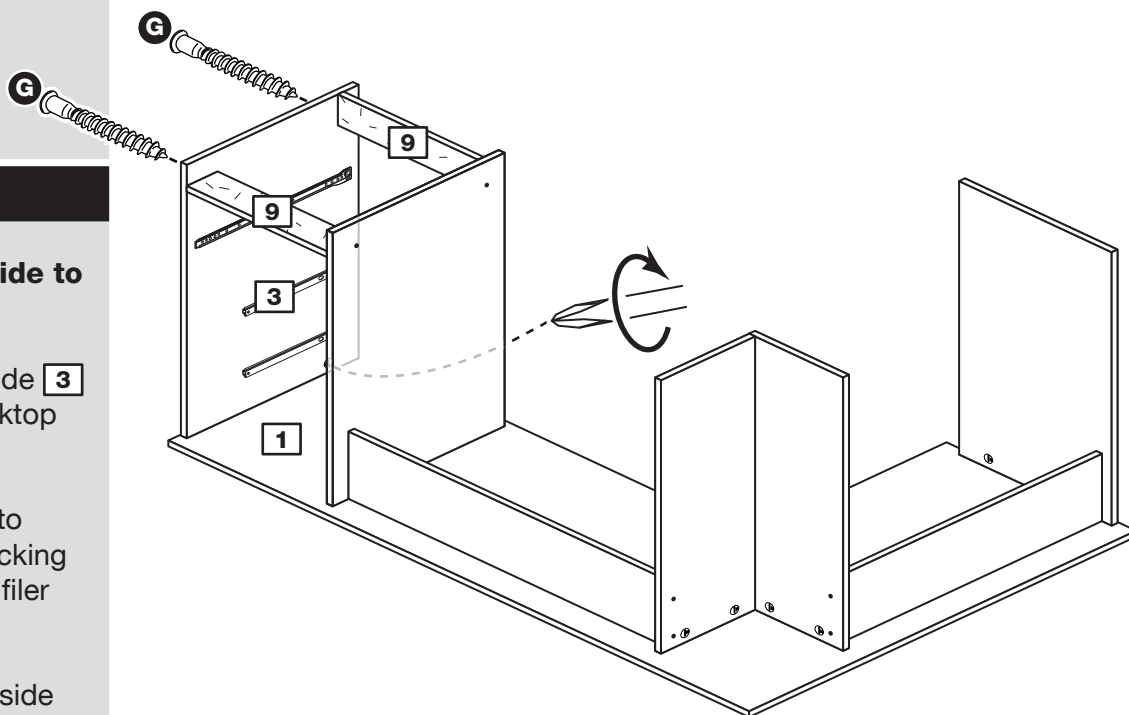

Assembly Instructions

Step 31

Fit the plastic nails

Tap 2 plastic nails **P** into the bottom edge of the right end **2**, filer left side **3**, filer right side **4**, left upright **5** and right upright **6**.

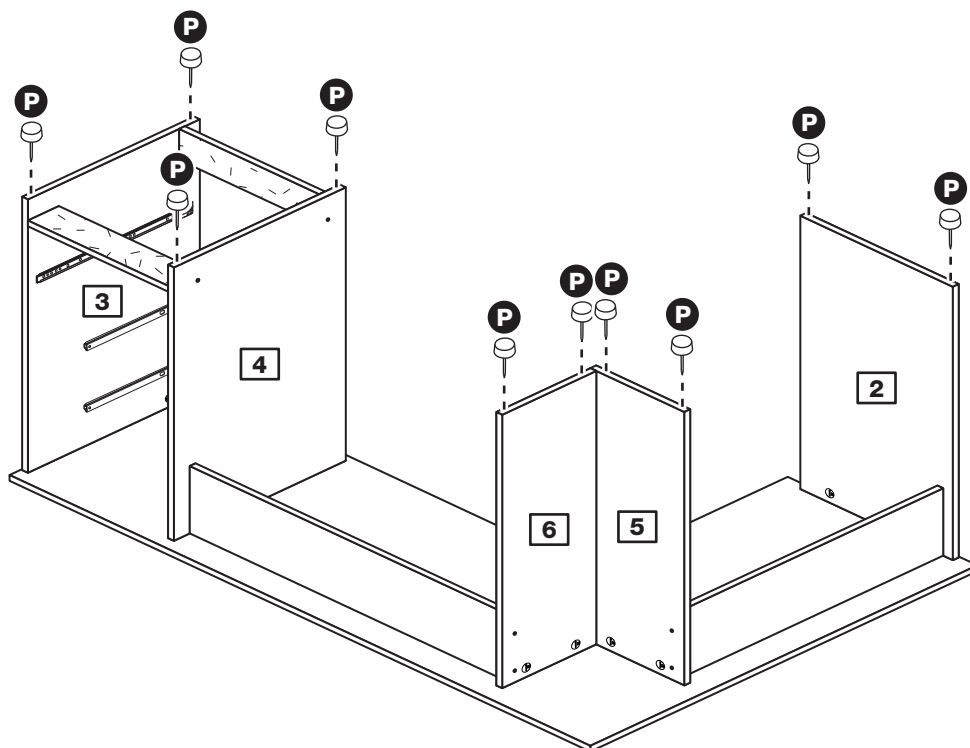

Step 32

Fit the back

a: Square up the filer section of the unit by making sure that measurement **x to x** equals **y to y**.

b: Position the back **18** onto the unit.

Nail **F** around the 3 outside edges of the back **18** as shown.

Note: Nails should be spaced about 150mm apart.

Using at least 2 people, carefully stand the unit up for the next step.

a: The measurement from top corner X to bottom corner X must be equal to the measurement from top corner Y to bottom corner Y

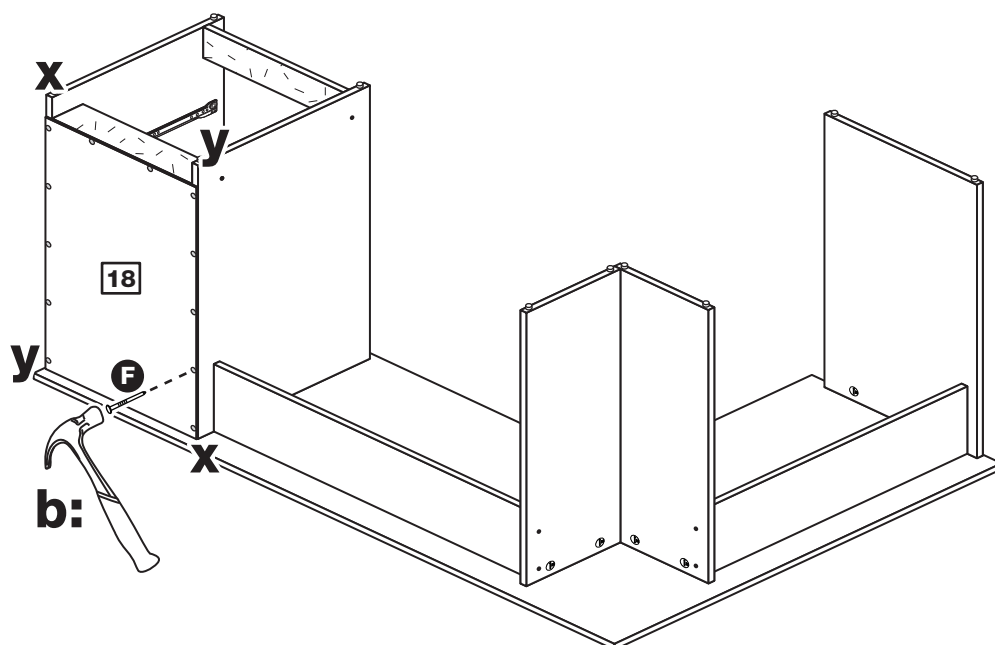

Assembly Instructions

Step 33

Fit the 2 drawers

Starting with the bottom drawer, slide both the runners **P** forward and locate the drawer sides **11** and **12** between them, lining up the holes in the drawer wrap with the 2nd 'threaded' holes in the runners **P**.

Working from the inside of the drawer, insert 2 screws **M** through the drawer sides and out into the 2nd threaded hole in the runner.

Note: Do not overtighten the screws **M**. If they catch on the runner you may need to loosen them slightly.

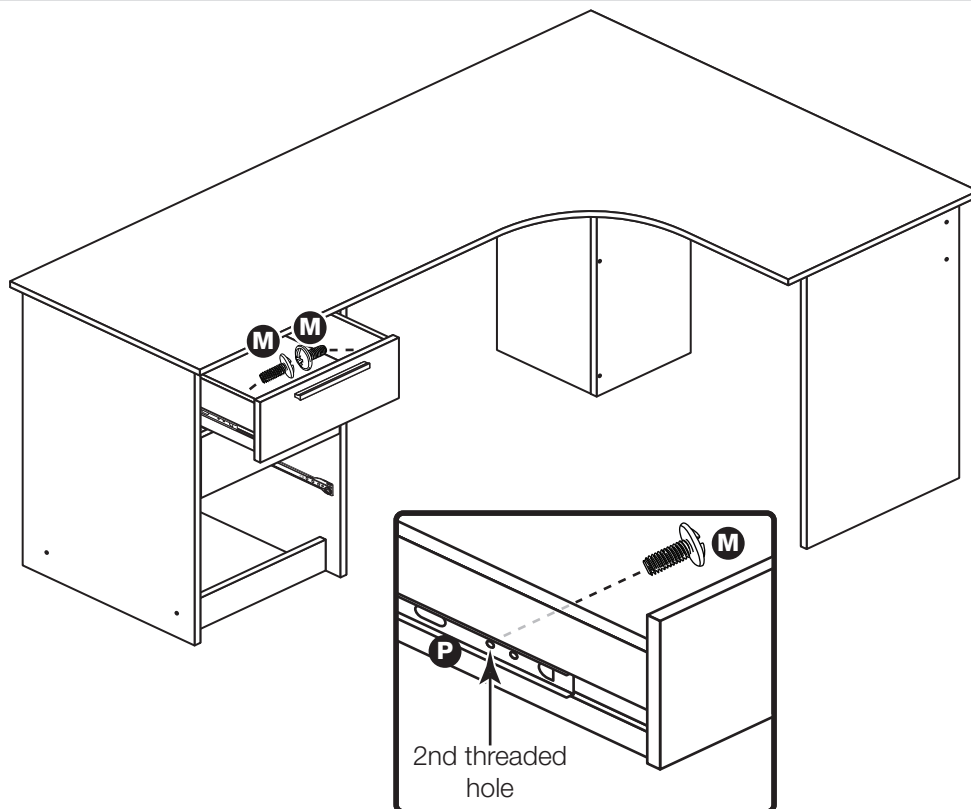

Step 34

Fit the filer drawer

Slide the wheels on the runners fitted to the filer drawer over the wheels of the runners fitted to the side panels and push the drawer into position.

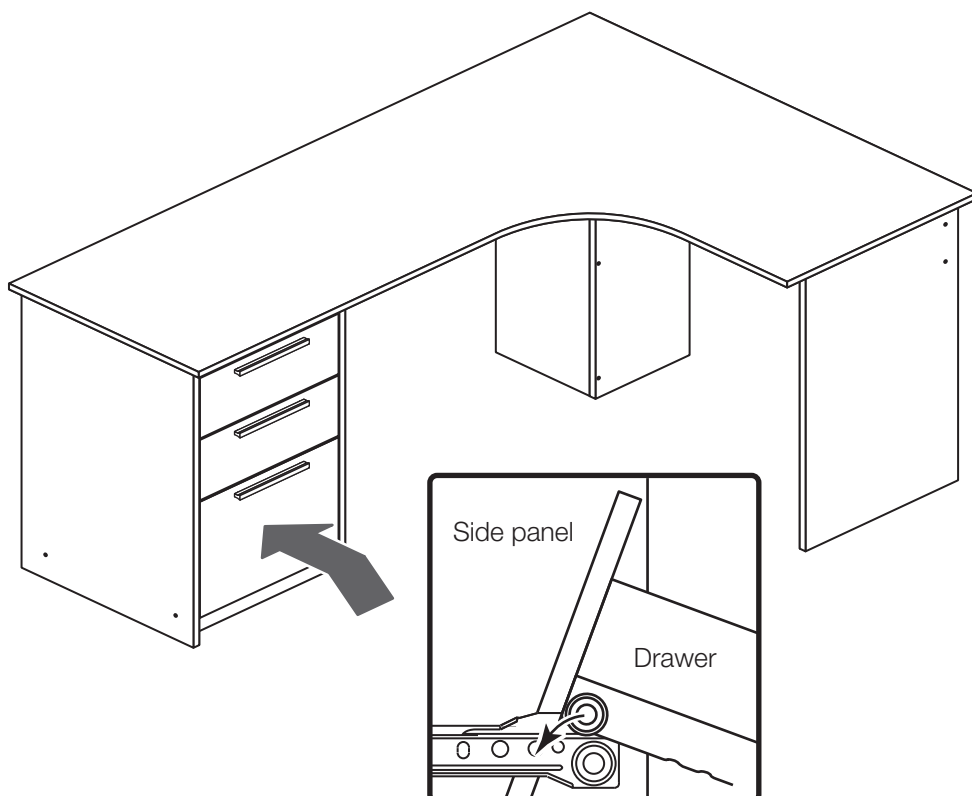

Assembly Instructions

Step 35

Assembly is complete

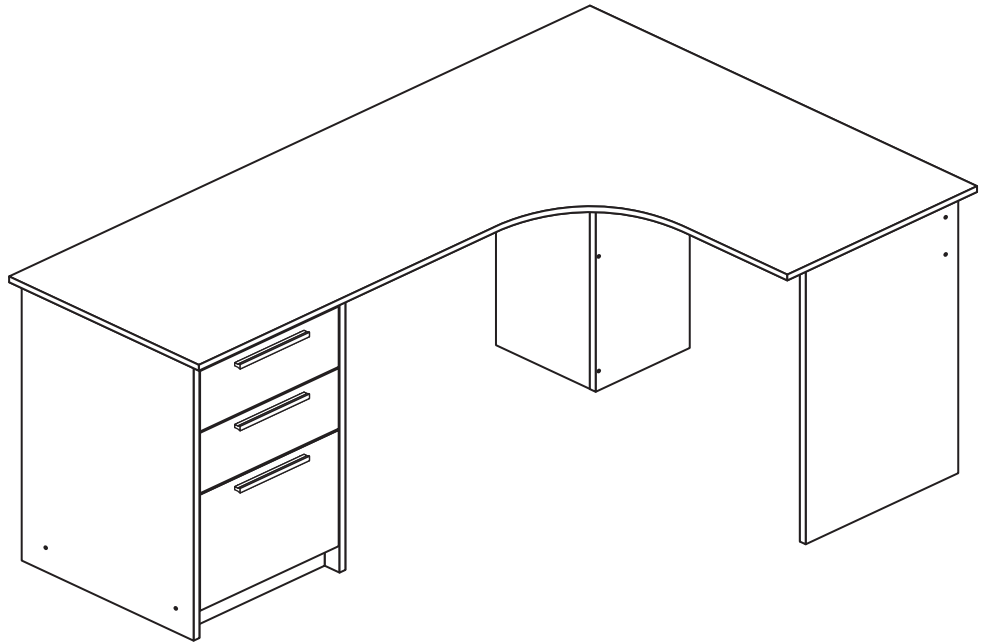

If you need help or have damaged or missing parts, call the **Customer Helpline: 03456 400800** and quote the reference numbers on the component pages.
Argos Ltd, 489-499 Avebury Boulevard, Central Milton Keynes, MK9 2NW

