

# Seville - Bedside

Assembly Instructions - Please keep for future reference

171/8140

170/9214

145/0446

157/3622

159/7732

160/9785

162/9325

162/7956

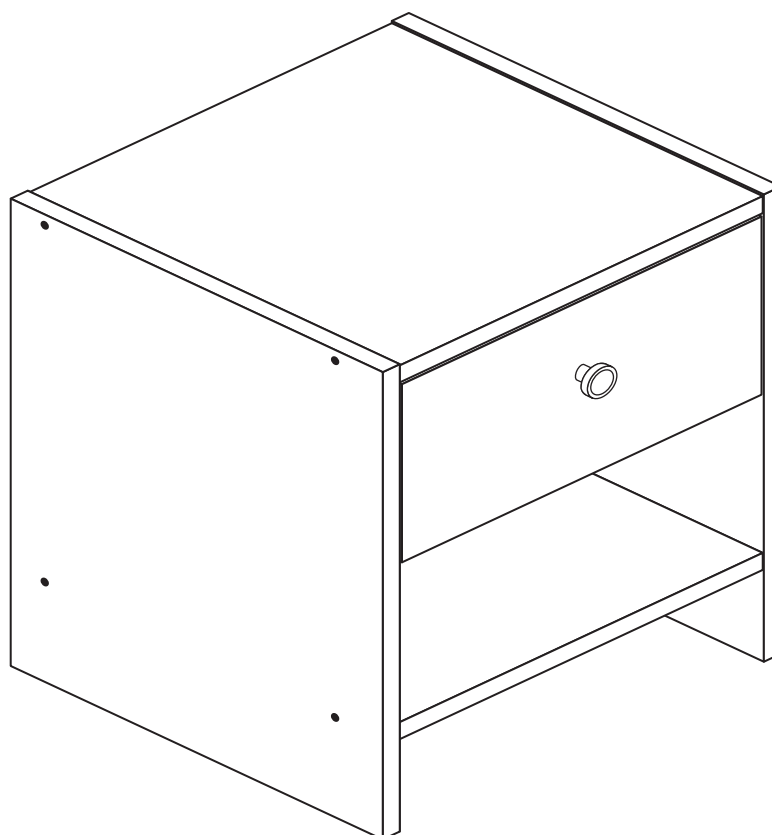

## Dimensions

Width - 35.5cm

Depth - 33cm

Height - 41.5cm



**MADE IN  
BRITAIN**

**Important** - Please read these instructions fully before starting assembly

If you need help or have damaged or missing parts, call the **Customer Helpline: 0870 112 1928** or email: [Help@ClickSpares.co.uk](mailto:Help@ClickSpares.co.uk) (quoting your original order number)



# Safety and Care Advice

**Important - Please read these instructions fully before starting assembly**

- **Warning:** This unit weighs approximately 7kgs. Please lift with care.

- Check you have all the components and tools listed on pages 2 and 3.

- Remove all fittings from the plastic bags and separate them into their groups.

- Keep children and animals away from the work area, small parts could choke if swallowed.

- Parts of the assembly will be easier with 2 people.

- Make sure you have enough space to layout the parts before starting.

- Do not stand or put weight on the product, this could cause damage.

- Assemble the item as close to its final position (in the same room) as possible.

- Assemble on a soft level surface to avoid damaging the unit or your floor (use opened out unit carton).



- We do not recommend the use of power drill/drivers **for inserting screws**, as this could damage the unit. Only use hand screwdrivers.

- **Safety note:** If there is any chance of this unit being pulled over by children etc. it is recommended that the unit is secured to a wall using suitable fixings (not supplied).

- Dispose of all packaging carefully and responsibly.

## Care and maintenance

- Only clean using a damp cloth and mild detergent, do not use bleach or abrasive cleaners.

- From time to time check that there are no loose screws on this unit.

- This product should not be discarded with household waste. Take to your local authority waste disposal centre.

**Note:** If required the next page can be cut out and used as reference throughout the assembly. Keep this page with these instructions for future reference.

# Components - Panels

If you have damaged or missing components, call the **Customer Helpline: 0870 112 1928** or email: **Help@ClickSpares.co.uk** (quoting your original order number and the reference numbers below)

Please check you have all the panels listed below

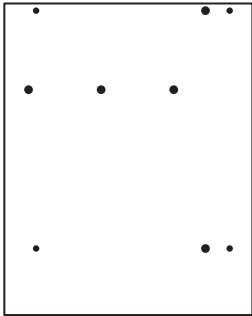

**1** Left Side (D2494A)  
(412 x 328mm)

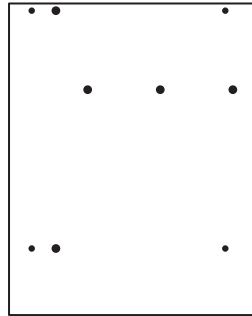

**2** Right Side (D2495A)  
(412 x 328mm)

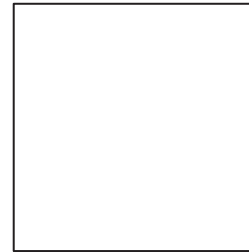

**3** Top/Base (D2493A)  
(321 x 327mm) x 2

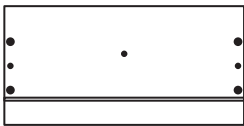

**4** Drawer Front (D2496A)  
(317 x 157mm)

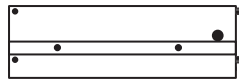

**5** Left Drawer Side (W410LH)  
(300 x 95mm)

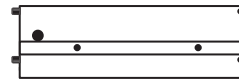

**6** Right Drawer Side (W410RH)  
(300 x 95mm)

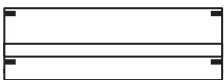

**7** Drawer Back (W288-95)  
(288 x 95mm)

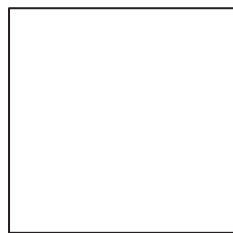

**8** Drawer Base (T299-297)  
(299 x 297mm)

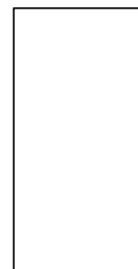

**9** Back (X175-347)  
(175 x 347mm)







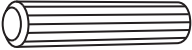
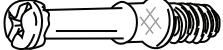

# Components - Fittings

If you have damaged or missing components, call the **Customer Helpline: 0870 112 1928** or **email: Help@ClickSpares.co.uk** (quoting your original order number and the reference numbers below)

Please check you have all the fittings listed below

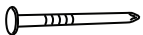
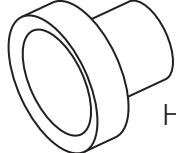
**Note:** The quantities below are the correct amount to complete the assembly. In some cases more fittings may be supplied than are required.

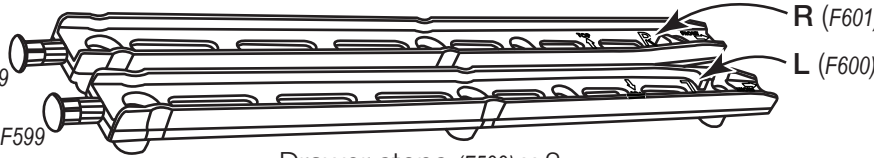
<p><b>A</b> </p> <p>Wooden dowel (F22) x 4</p>	<p><b>B</b> </p> <p>Metal dowel (F901) x 2</p>	<p><b>C</b> </p> <p>Small locking nut (F3) x 2</p>
<p><b>D</b> </p> <p>40mm Screw (F910) x 8</p>	<p><b>E</b> </p> <p>25mm Screw (F95) x 1</p>	<p><b>F</b> </p> <p>Nail (F51) x 5</p>
<p><b>G</b> </p> <p>Handle (F300) x 1</p>	<p><b>H</b> </p> <p>Knock-in Peg (F171WH) x 4</p>	
<p><b>I</b> </p> <p>Drawer stops (F599) x 2 Runners (F600) x 1 and (F601) x 1</p>		

## Tools required

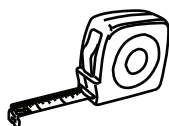

Rule



Cross-head screwdriver



Scissors



Hammer



Eye protection (when using a hammer or drill)

## Ruler - Use this ruler to help correctly identify the screws

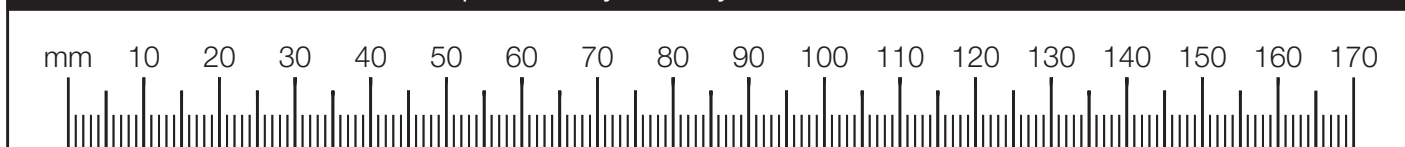

# Assembly Instructions

If you have damaged or missing components, call the **Customer Helpline: 0870 112 1928** or email: **Help@ClickSpares.co.uk** (quoting your original order number and the reference numbers below)

## Step 1

### Prepare the drawer front

Screw 2 metal dowels **B** into the holes shown on the back of the drawer front **4**.

**Note:** Tighten metal dowels up fully against the panels.

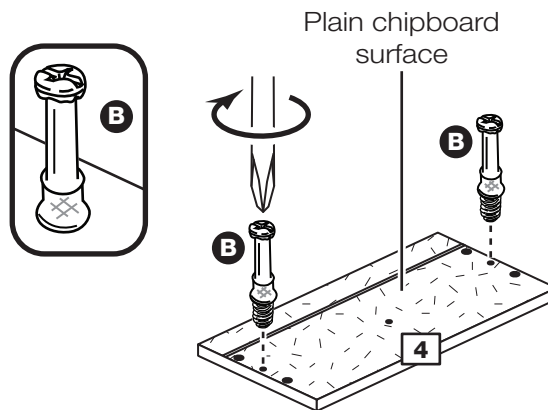

## Step 2

### Prepare the drawer sides

Insert a small locking nut **C** into the hole shown on the left drawer side **5** and right drawer side **6**.

**Note:** Arrow on locking nut **must** point towards hole in edge of panel.

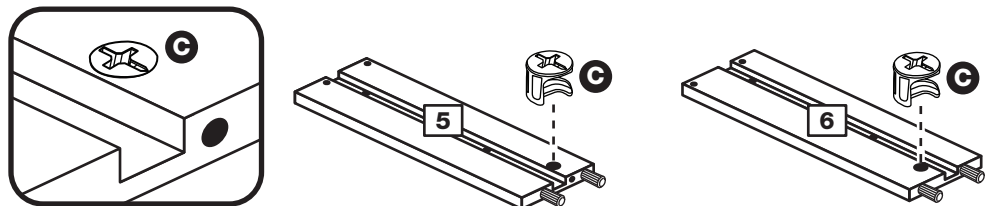

## Step 3

### Attach the drawer sides to the drawer front

Push the left drawer side **5** and right drawer side **6** onto the back of the drawer front **4**.

Turn the small locking nuts **C** on the left drawer side **5** and right drawer side **6**.

**Note:** Turn the locking nuts **C** clockwise to secure panels - more than 1/2 a turn.

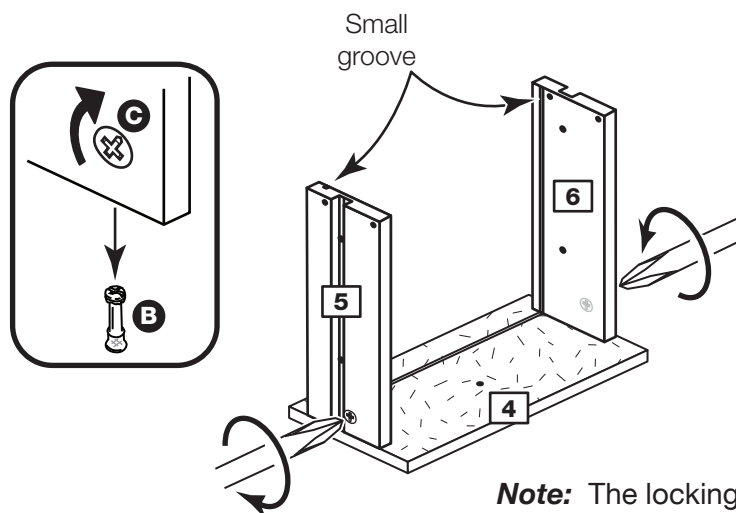

**Note:** The locking nuts can be on either surface of the drawer sides. Make sure that the small groove is on the inside, as shown.

# Assembly Instructions

## Step 4

### Fit the drawer base

Slide the drawer base **8** down the grooves in the drawer sides **5** and **6** and down into the groove in the drawer front **4**.

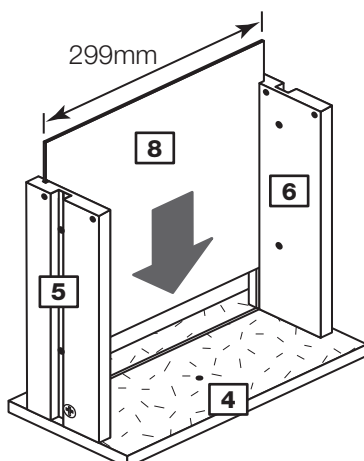

## Step 5

### Fit the drawer back

Fit the drawer back **7** between the drawer sides **5** and **6**.

Make sure that the drawer base **8** fits into the groove in the drawer back **7**.

Hold the drawer back **7** in position and tap the knock-in pegs **H** through the holes in the drawer sides **5** and **6**.

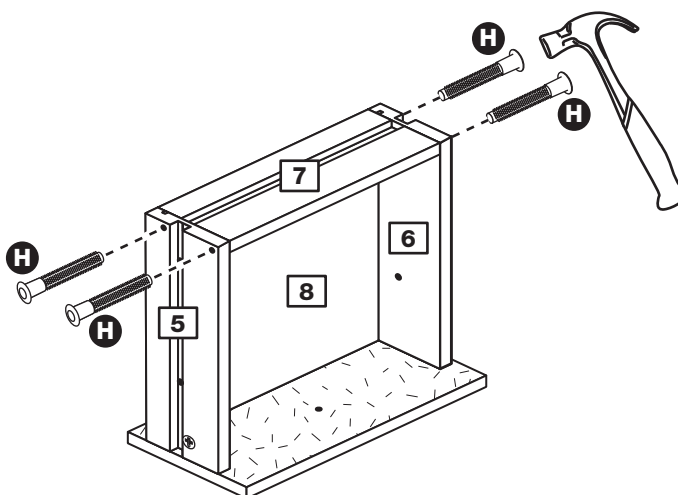

## Step 6

### Push in drawer stops

Carefully break off the 2 drawer stops (F599) from the drawer runners **1**.

Push the drawer stops fully through the drawer sides **5** and **6** from the inside.

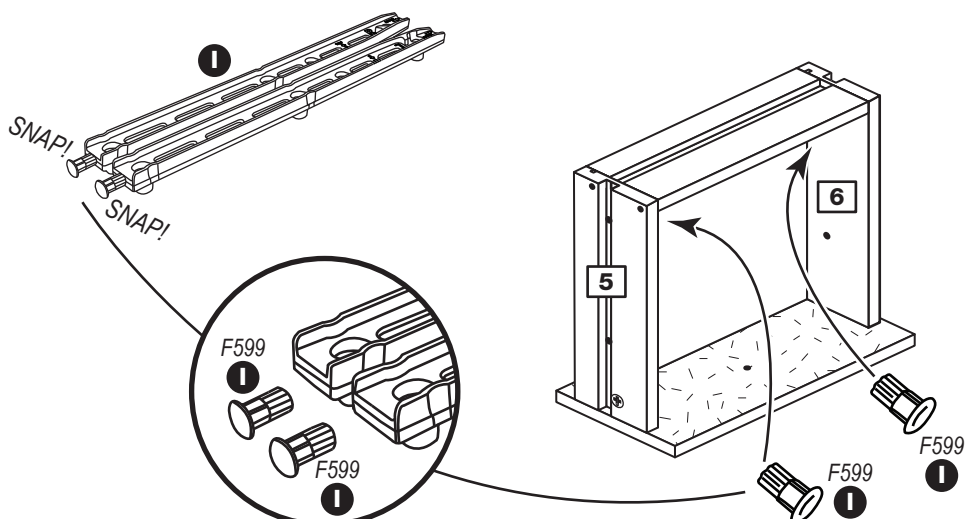

# Assembly Instructions

## Step 7

### Attach the handle

Attach the handle **G** to the drawer front **4** using screw **E**.

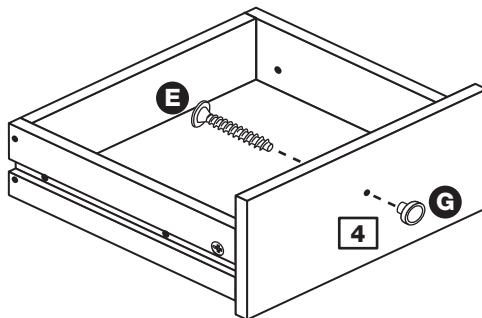

## Step 8

### Prepare the left side

Separate the runners **1**.

Push fit the left runner **1** marked 'L' into the left side **1**.

**Note:** Runners must be fitted flat against the panel. If necessary gently tap into final position.

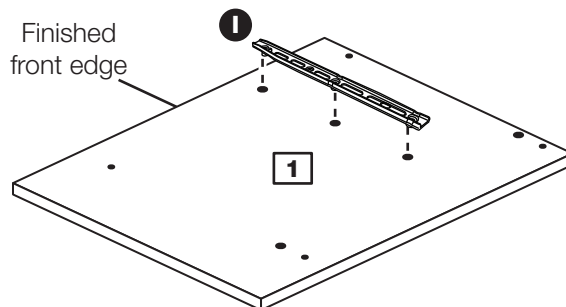
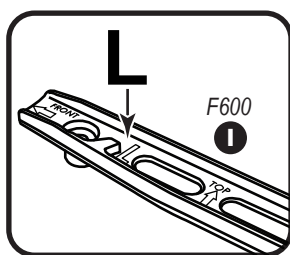

## Step 9

### Prepare the right side

Push fit the left runner **1** marked 'R' into the right side **2**.

**Note:** Runners must be fitted flat against the panel. If necessary gently tap into final position.

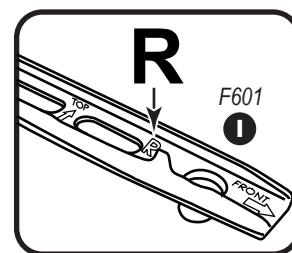
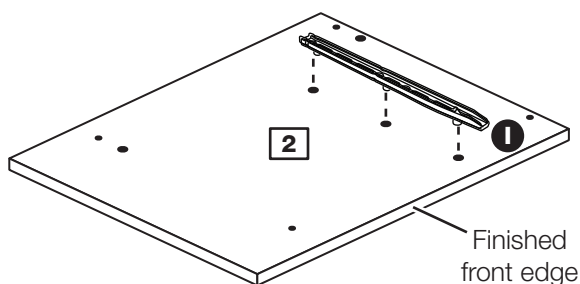

# Assembly Instructions

## Step 10

### Prepare the top and the base

Tap 2 wooden dowels **A** into the top **3** and the base **3**.

x 2

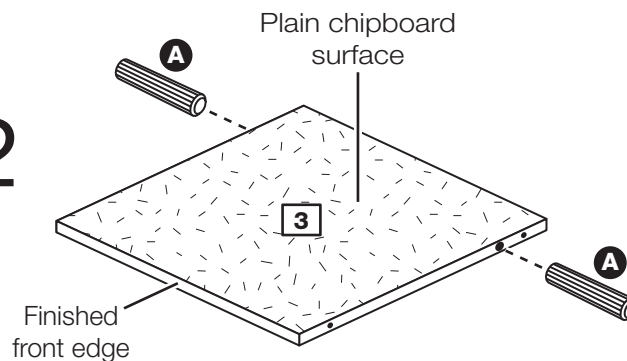

## Step 11

### Join the top to the right side

Push the top **3** onto the right side **2** and secure with 2 screws **D**.

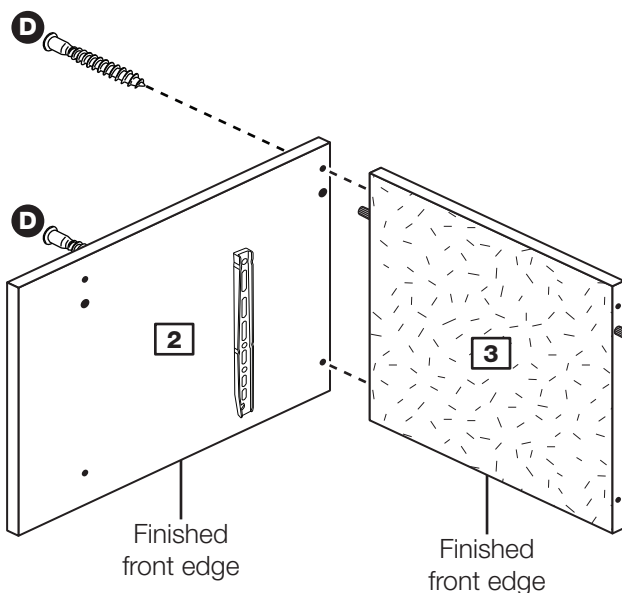

## Step 12

### Join the base to the right side

Push the base **3** onto the right side **2** and secure with 2 screws **D**.

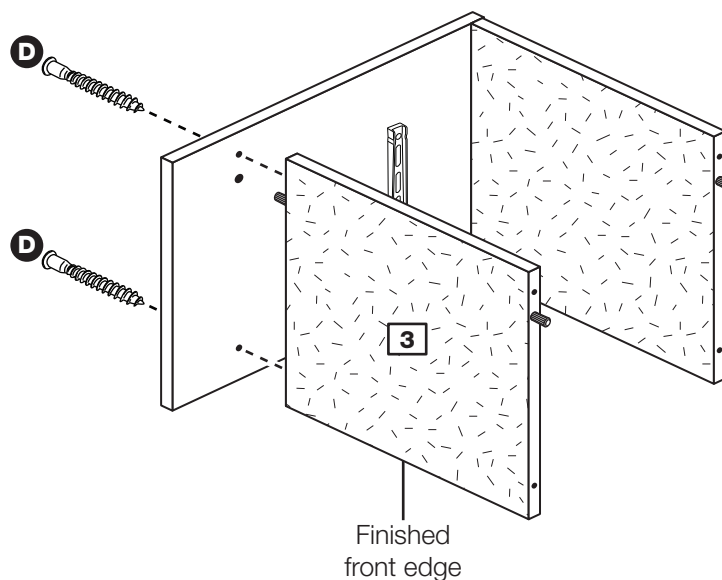



# Assembly Instructions

## Step 13

### Fit the left side

Push the left side **1** onto the assembly and secure with 4 screws **D**.

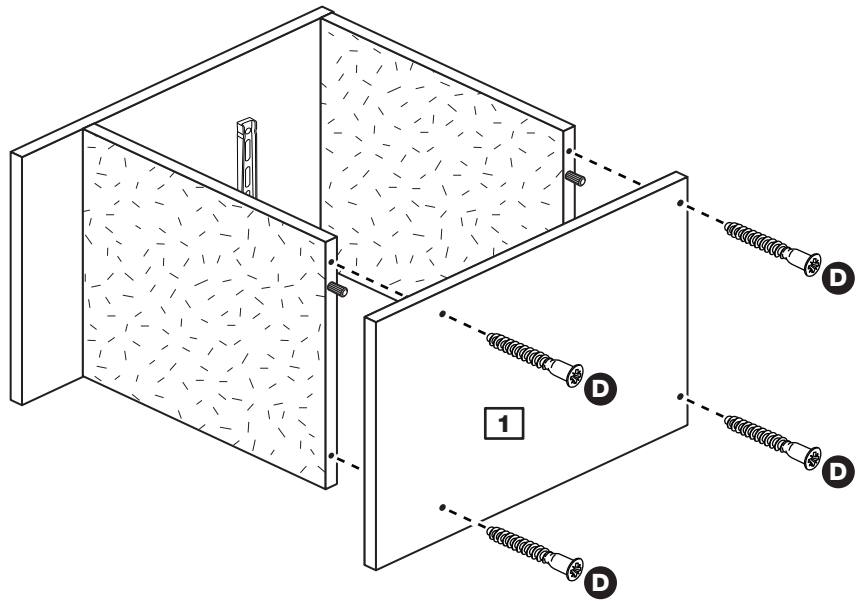

## Step 14

### Fit the back

**a:** Square up the unit by making sure that measurement **x to x** equals **y to y**.

**b:** Place the back **9** onto the unit.

Nail **F** around the 3 edges of the back **9** as shown.

**Stand the unit up for the next step.**

**a:** The measurement from top corner X to bottom corner X must be equal to the measurement from top corner Y to bottom corner Y

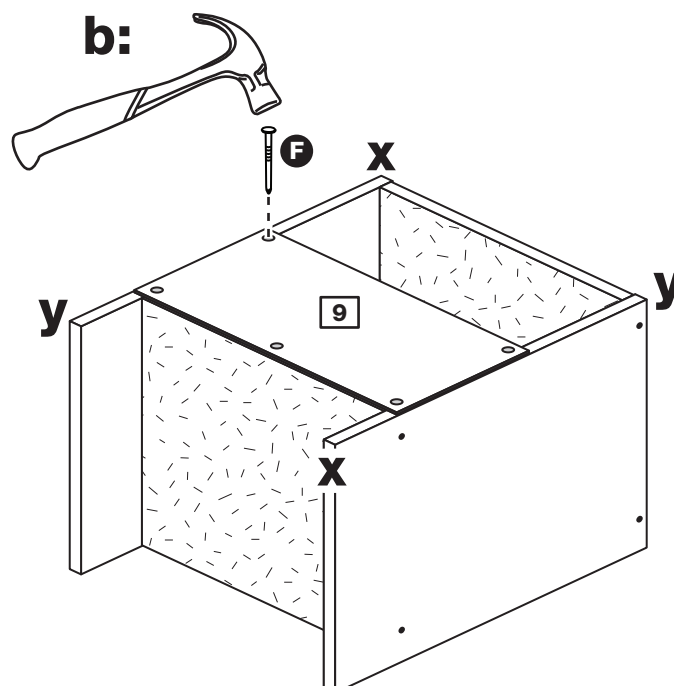

# Assembly Instructions

## Step 15

### Insert the drawer

Lift the front of the drawer whilst inserting to overcome the 'stop' system.

**Note:** To ensure that your drawer runs smoothly, spray a small amount of furniture polish into the grooves.

**Assembly is complete**

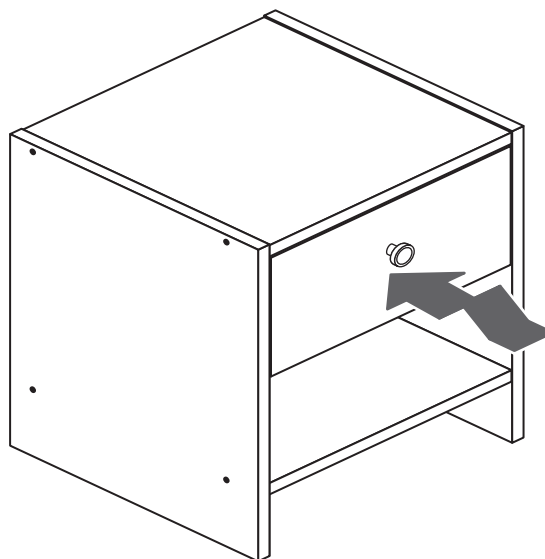

If you need help or have damaged or missing parts, call the **Customer Helpline: 0870 112 1928** or email: **Help@ClickSpares.co.uk** (quoting your original order number and the reference numbers on the component pages)  
Argos Ltd, 489-499 Avebury Boulevard, Central Milton Keynes, MK9 2NW





# Seville - 3 Door Robe

Assembly Instructions - Please keep for future reference

147/4556

171/6939

167/8338

173/6146

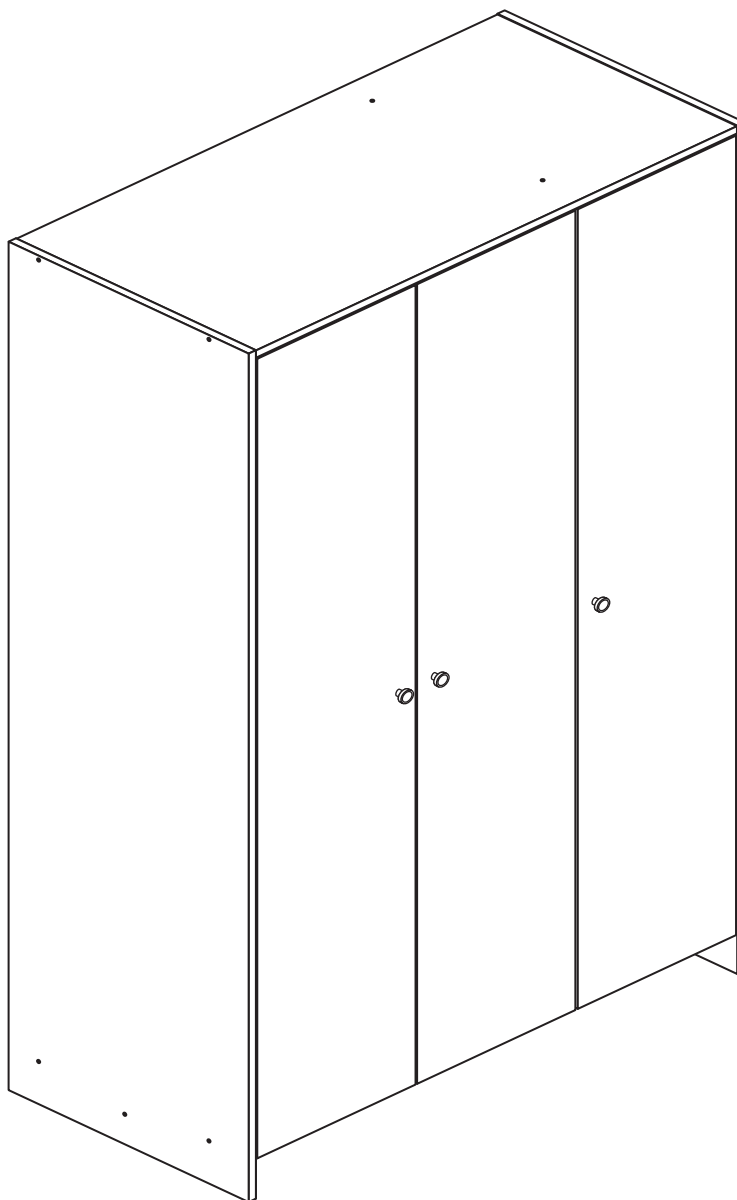

## Dimensions

Width - 102.5cm

Depth - 49.5cm

Height - 175.5cm



**MADE IN  
BRITAIN**

**Important** - Please read these instructions fully before starting assembly

If you need help or have damaged or missing parts, call the **Customer Helpline: 0870 112 1928** or email: [Help@ClickSpares.co.uk](mailto:Help@ClickSpares.co.uk) (quoting your original order number)



# Safety and Care Advice

**Important - Please read these instructions fully before starting assembly**

- **Warning:** This unit weighs approximately 59kgs. Please lift with care.

- Check you have all the components and tools listed on pages 2 and 3.

- Remove all fittings from the plastic bags and separate them into their groups.

- Keep children and animals away from the work area, small parts could choke if swallowed.

- Parts of the assembly will be easier with 2 people.

- Make sure you have enough space to layout the parts before starting.

- Do not stand or put weight on the product, this could cause damage.

- Assemble the item as close to its final position (in the same room) as possible.

- Assemble on a soft level surface to avoid damaging the unit or your floor (use opened out unit carton).



- We do not recommend the use of power drill/drivers **for inserting screws**, as this could damage the unit. Only use hand screwdrivers.

- **Safety note:** It is recommended that this unit is secured to a wall using the bracket supplied.

- Dispose of all packaging carefully and responsibly.

## Care and maintenance

- Only clean using a damp cloth and mild detergent, do not use bleach or abrasive cleaners.

- From time to time check that there are no loose screws on this unit.

- This product should not be discarded with household waste. Take to your local authority waste disposal centre.

**Note:** If required the next page can be cut out and used as reference throughout the assembly. Keep this page with these instructions for future reference.

# Components - Panels

If you have damaged or missing components, call the **Customer Helpline: 0870 112 1928** or email: **Help@ClickSpares.co.uk** (quoting your original order number and the reference numbers below)

Please check you have all the panels listed below

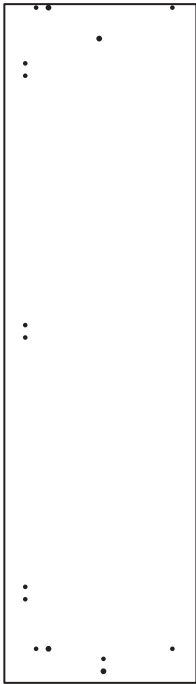

**1** Left Side (D2483A)  
(1753 x 496mm)

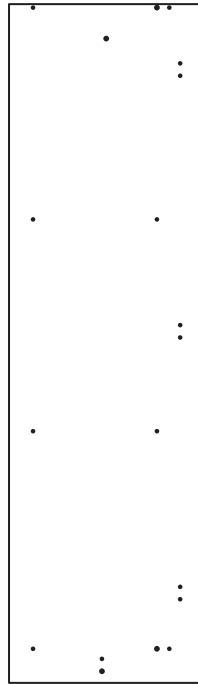

**2** Right Side (D2497A)  
(1753 x 496mm)

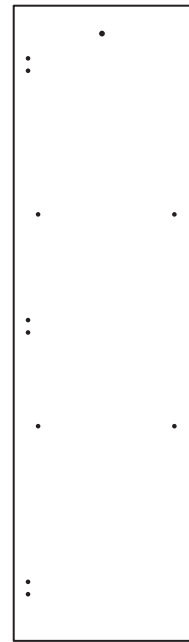

**3** Upright (D2500A)  
(1640.5 x 477mm)

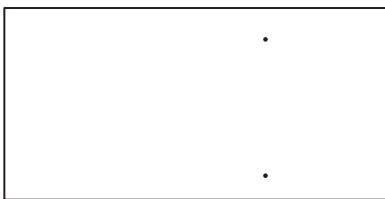

**4** Top (D2498A)  
(995 x 495mm)

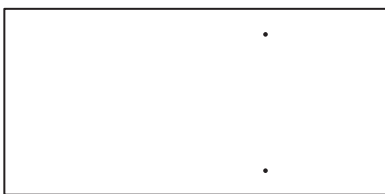

**5** Base (D2499A)  
(995 x 480mm)



**6** Plinth (D2502A)  
(995 x 80mm)



**7** Shelf (D2501A)  
(313 x 475mm) x 2



**8** Hanging Rail (FHR659)  
(659mm long)

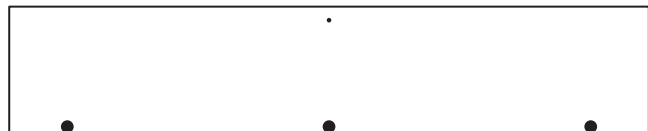

**9** Door (D2487A)  
(1652 x 327mm) x 3

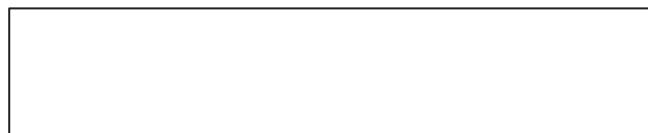

**10** Small Back (X1666-332)  
(1666 x 332mm)

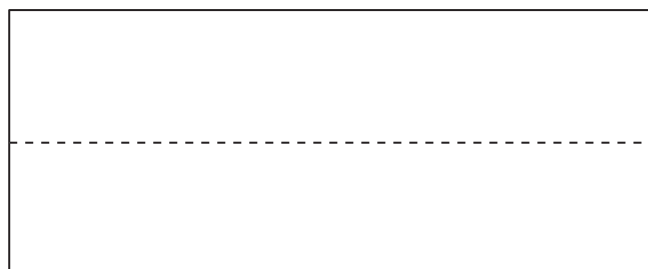

**11** Large Back (X1666-685)  
(1666 x 685mm)











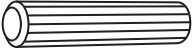
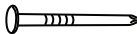

# Components - Fittings

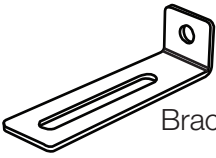

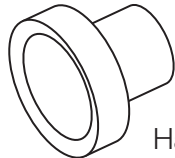

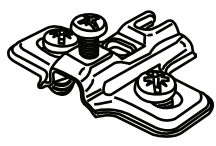
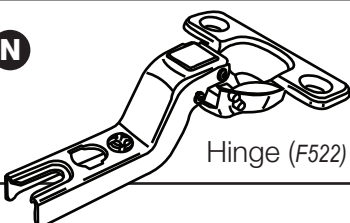

If you have damaged or missing components, call the **Customer Helpline: 0870 112 1928** or **email: Help@ClickSpares.co.uk** (quoting your original order number and the reference numbers below)

Please check you have all the fittings listed below

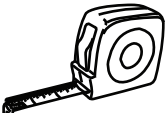
**Note:** The quantities below are the correct amount to complete the assembly. In some cases more fittings may be supplied than are required.

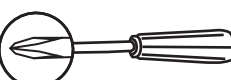
<p><b>A</b> </p> <p>Wooden dowel (F22) x 6</p>	<p><b>B</b> </p> <p>Nail (F51) x 36</p>	<p><b>C</b> </p> <p>40mm Screw (F910) x 14</p>
<p><b>D</b> </p> <p>25mm Screw (F95) x 3</p>	<p><b>E</b> </p> <p>13mm Screw (F79) x 1</p>	<p><b>F</b> </p> <p>13mm Screw (F63) x 20</p>
<p><b>G</b> </p> <p>Bracket (F327) x 1</p>	<p><b>H</b> </p> <p>Rail holder (F1014) x 2</p>	<p><b>I</b> </p> <p>Handle (F300) x 3</p>
<p><b>J</b> </p> <p>Back holder (F276) x 5 *These can also be round</p>	<p><b>K</b> </p> <p>Nail screw (F277) x 5</p>	<p><b>L</b> </p> <p>Shelf support (F121) x 8</p>
<p><b>M</b> </p> <p>Hinge plate (F523) x 9</p>	<p><b>N</b> </p> <p>Hinge (F522) x 9</p>	

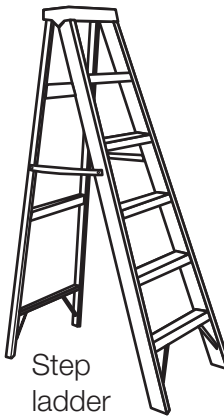
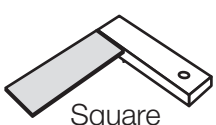
## Tools required

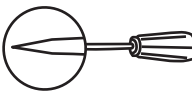
<p></p> <p>Rule</p>	<p></p> <p>Spirit level</p>	<p></p> <p>Eye protection (when using a hammer or drill)</p>	<p></p> <p>Cross-head screwdriver</p>	<p></p> <p>Electric drill (only use when drilling into walls)</p>	<p></p> <p>Step ladder</p>
<p></p> <p>Square</p>	<p></p> <p>Scissors</p>	<p></p> <p>Hammer</p>	<p></p> <p>Bradawl</p>		

**Ruler** - Use this ruler to help correctly identify the screws

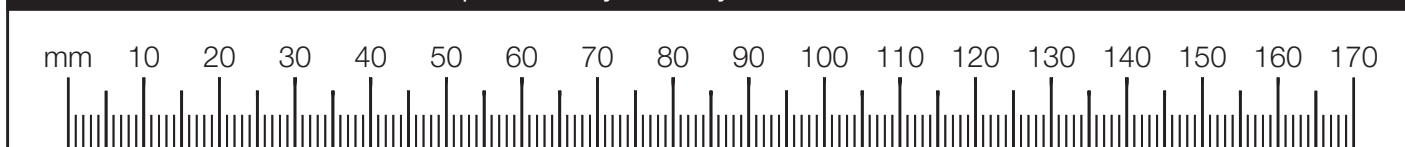



# Assembly Instructions

If you have damaged or missing components, call the Customer Helpline: 0870 112 1928 or email: [Help@ClickSpares.co.uk](mailto:Help@ClickSpares.co.uk) (quoting your original order number and the reference numbers below)

## Step 1

### Prepare the top and base

Tap 2 wooden dowels **A** into the top **4**.

Tap 2 wooden dowels **A** into the base **5**.

**Note:** Wooden dowels **must not** stick out from the edge by more than 10mm or they may damage other panels.

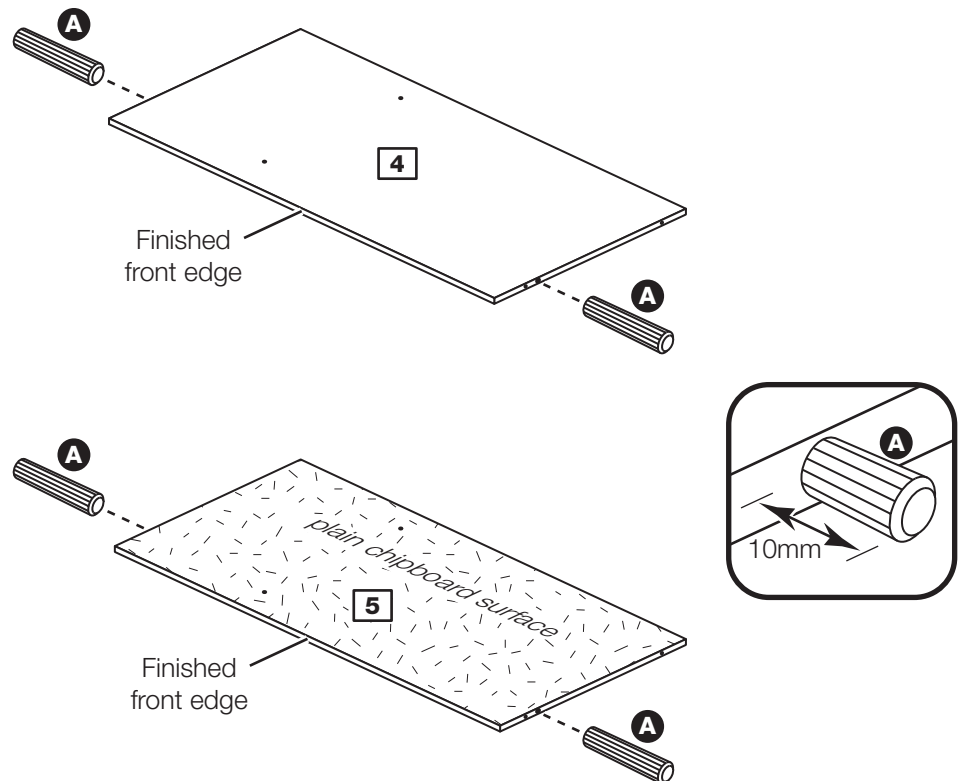

## Step 2

### Prepare the upright

Push a rail holder **H** into the upright **3**. Make sure that it is fitted straight, in line with the panel edges and then secure with screw **F**.

Fit 3 hinge plates **M** onto the upright **3**, making sure that the slot is facing towards the finished front edge.

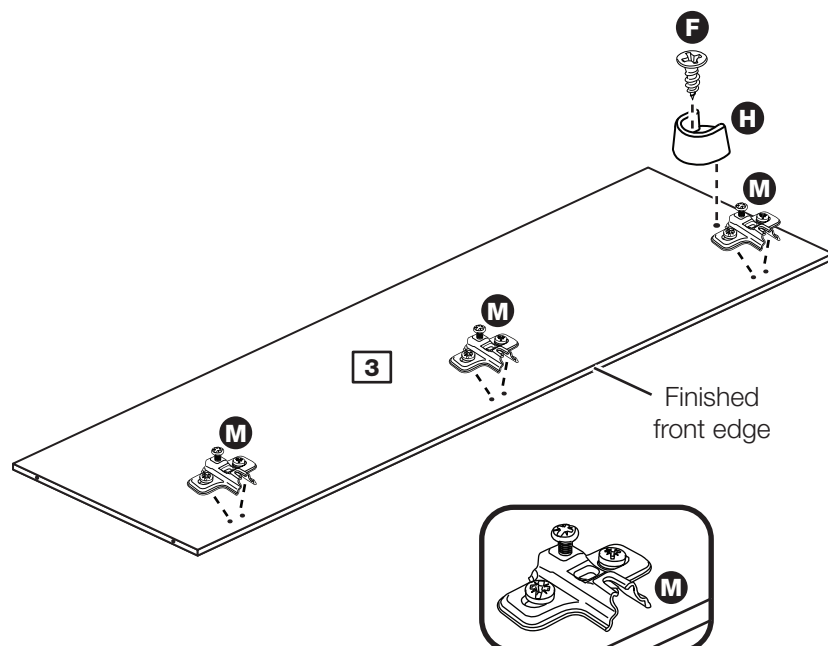

# Assembly Instructions

## Step 3

### Fit the top and the base to the upright

Fit the top **4** and the base **5** onto the upright **3** using 4 screws **C**.

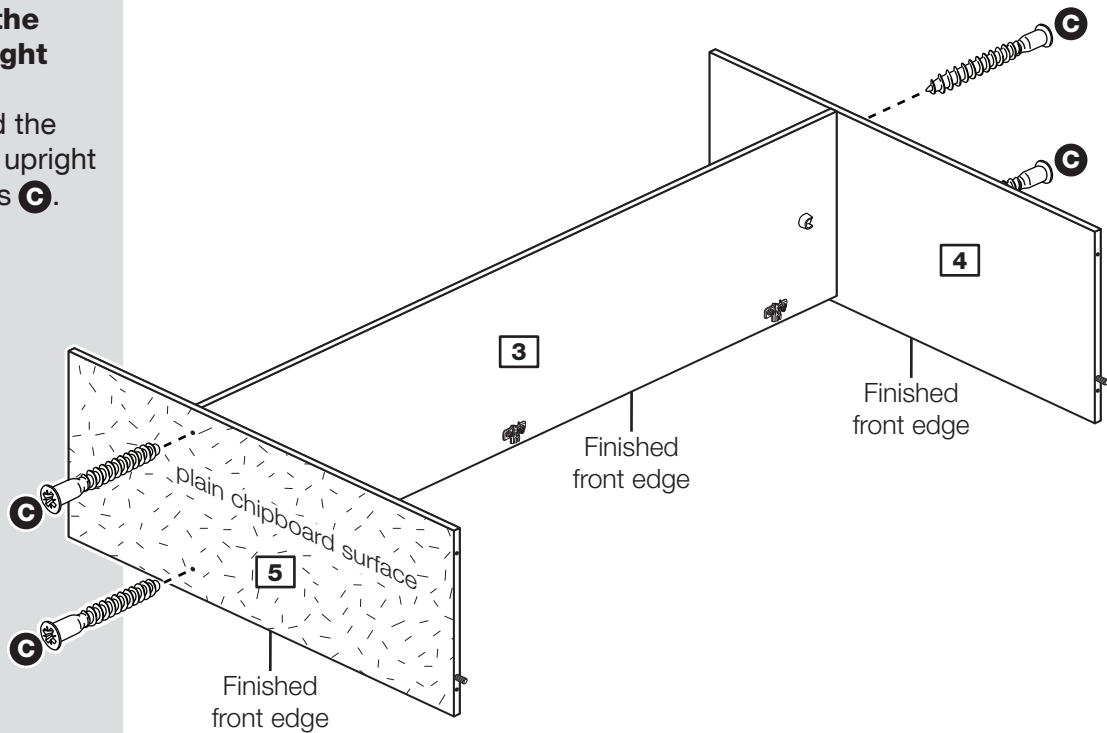

## Step 4

### Prepare the right side

Fit 3 hinge plates **M** onto the right side **2**, making sure that the slot is facing towards the finished front edge.

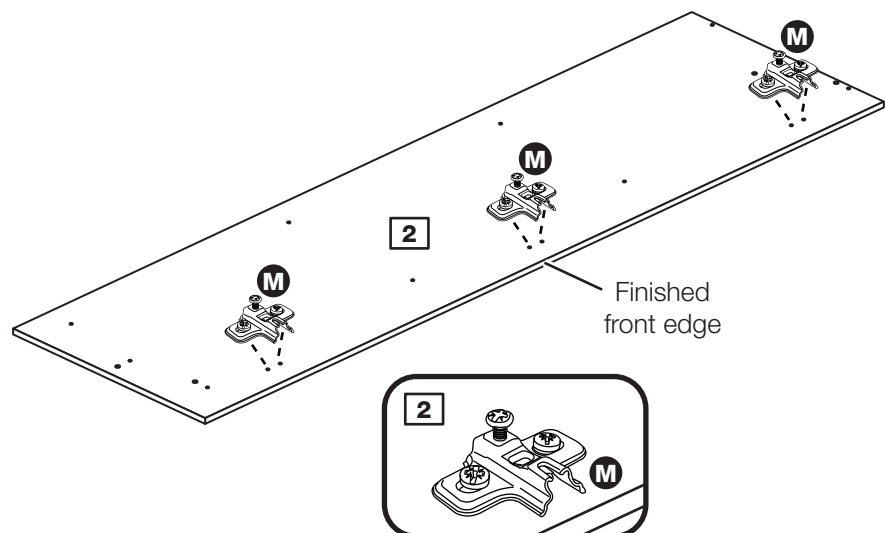

# Assembly Instructions

## Step 5

### Fit the right side

Push the right side **2** onto the top **4** and base **5** and secure it using 4 screws **C**.

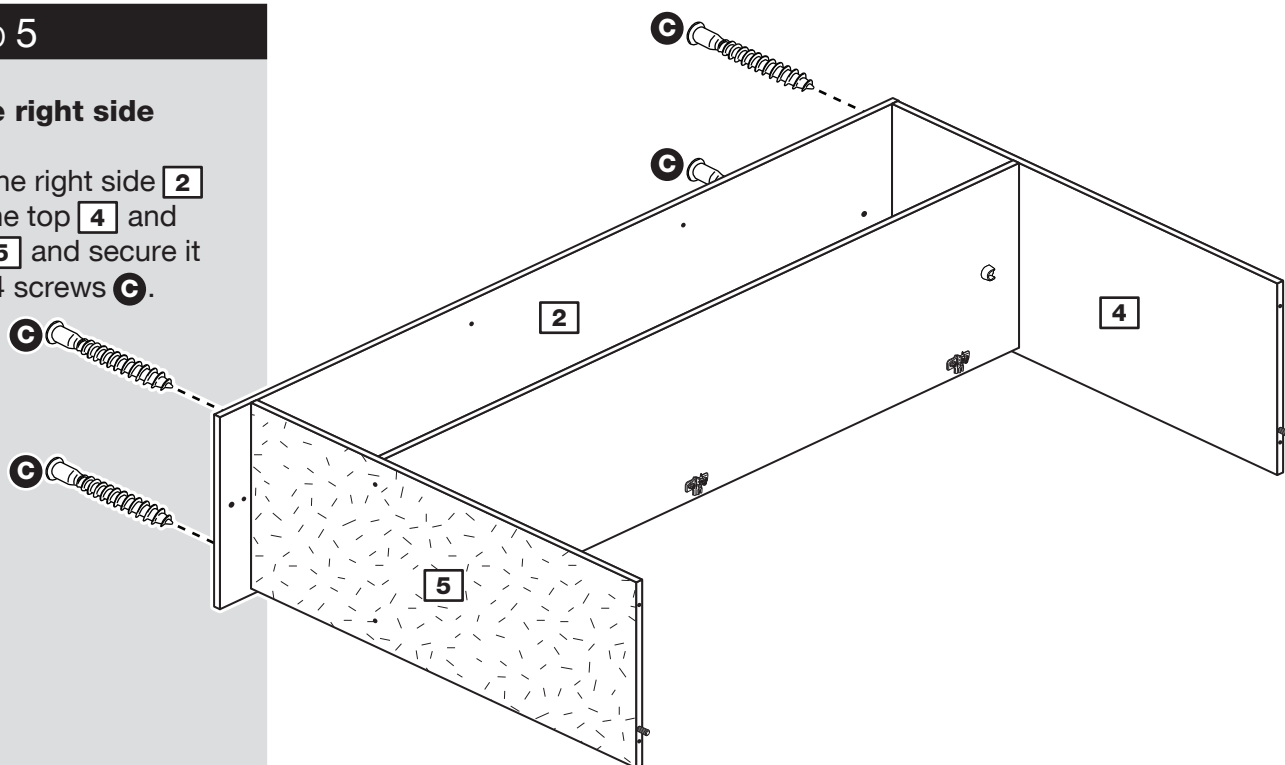

## Step 6

### Prepare the plinth

Tap 2 wooden dowels **A** into the plinth **6**.

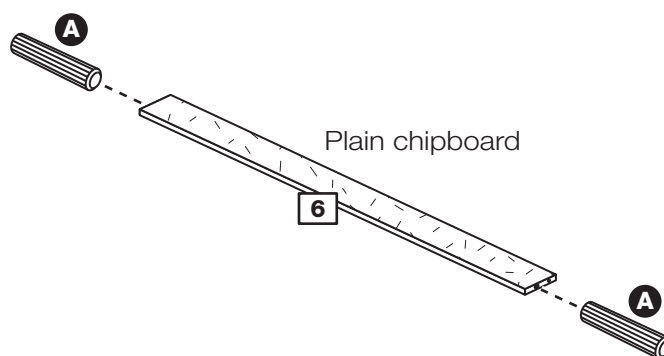

## Step 7

### Prepare the left side

Push a rail holder **H** into the left side **1**. Make sure that it is fitted straight, in line with the panel edges and then secure with screw **F**.

Fit 3 hinge plates **M** onto the left side **1**, making sure that the slot is facing towards the finished front edge.

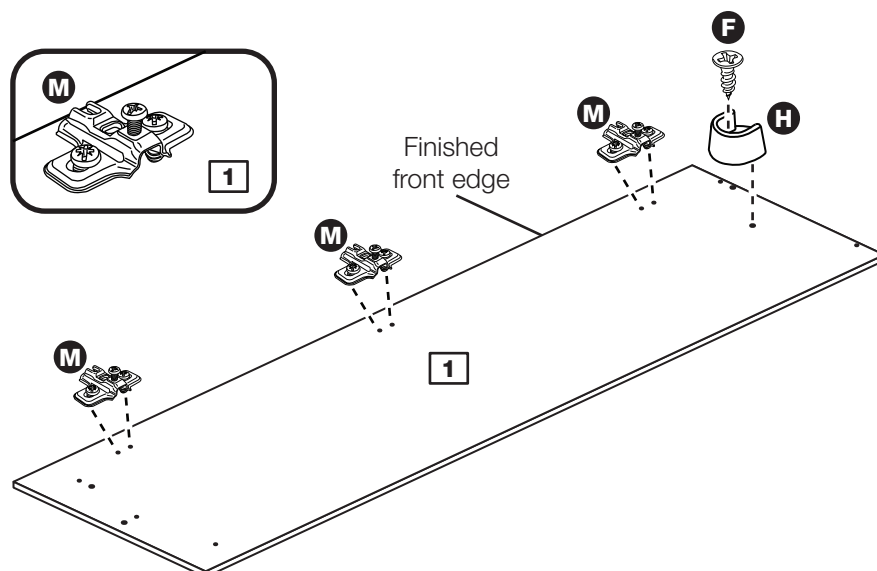

# Assembly Instructions

## Step 8

### Fit the plinth

Push the plinth **6** onto the right side **2** and secure it using screw **C**.

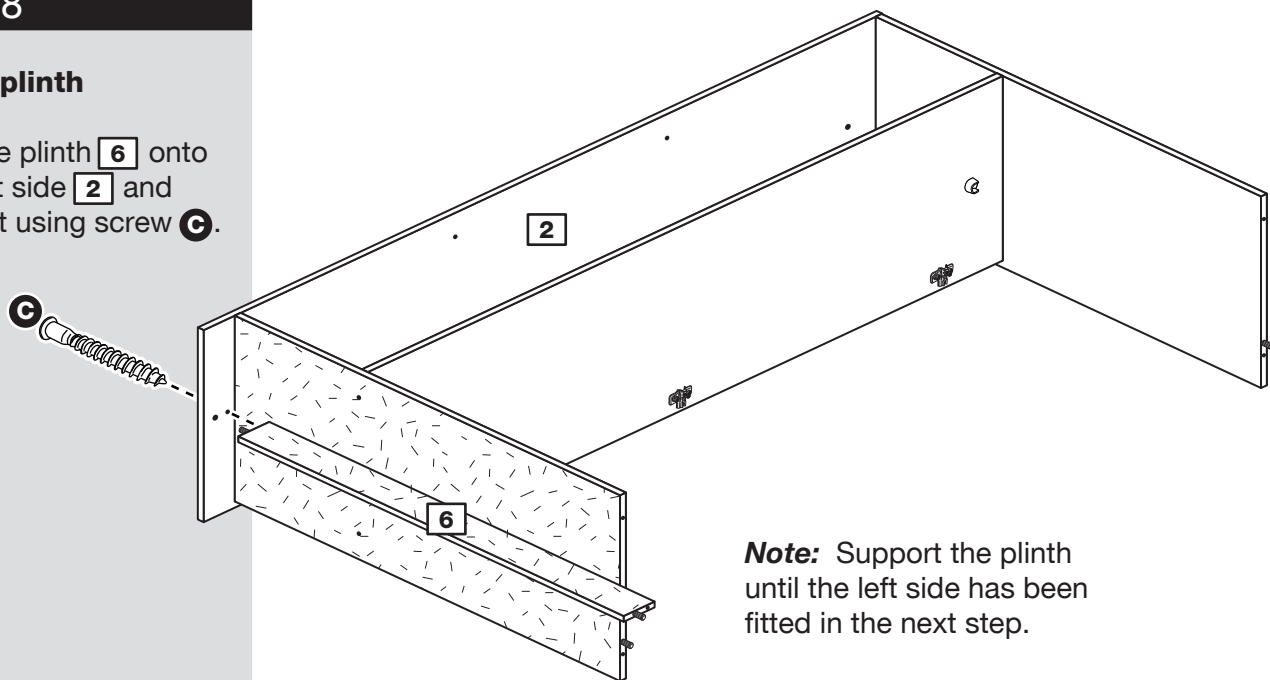

**Note:** Support the plinth until the left side has been fitted in the next step.

## Step 9

### Fit the left side

Push the left side **1** onto the assembly and secure it using 5 screws **C**.

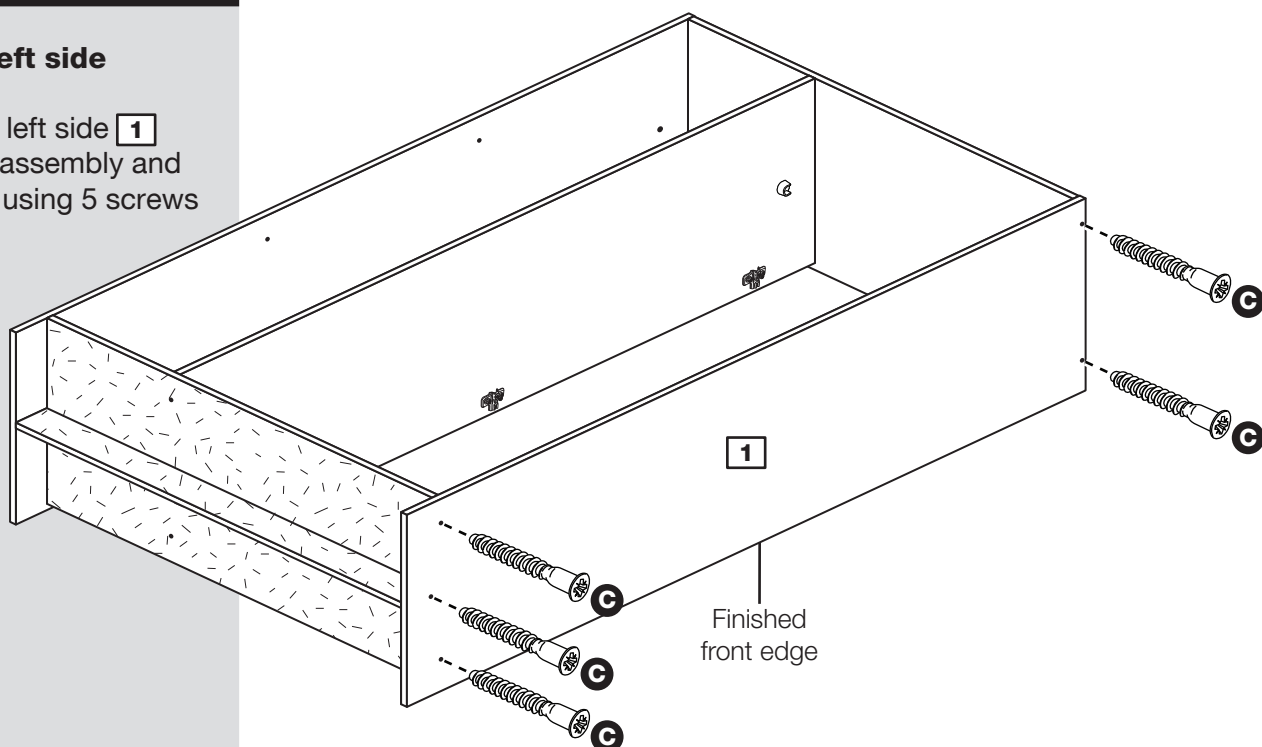

# Assembly Instructions

## Step 10

### Fit the back

**a:** Square up the unit by making sure that measurement **x** to **x** equals **y** to **y**.

Place the small back **10** and large back **11** down onto the unit as shown.

Make sure that the 2 backs are pushed up tight against each other and that they meet over the back edge of the upright.

**b:** Nail **B** around the outside edges of the 2 backs.

**Note:** Do not nail where the backs meet. Nails should be spaced about 150mm apart.

**a:** The measurement from top corner X to bottom corner X must be equal to the measurement from top corner Y to bottom corner Y

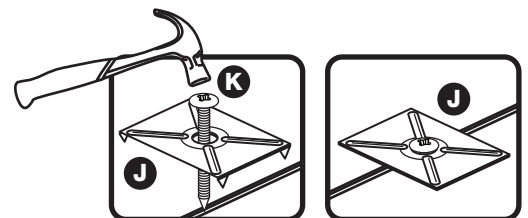
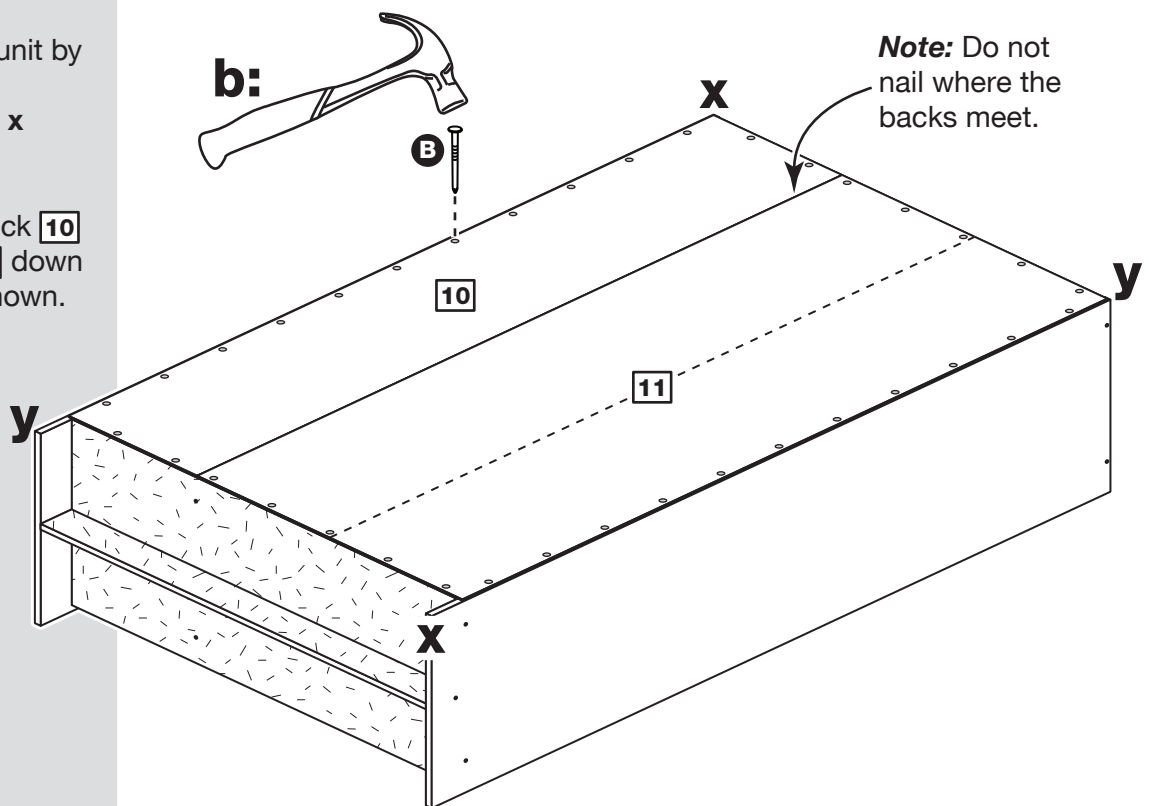

**Note:** These can also be round

## Step 11

### Secure the backs

Tap the nail screws **K** through the back holders **J** and down between the backs **10** and **11** into the back edge of the divider.

Keep tapping the nail screws **K** in until the back holders **J** dig into the small and large back.

**Stand the unit up for the next step.**

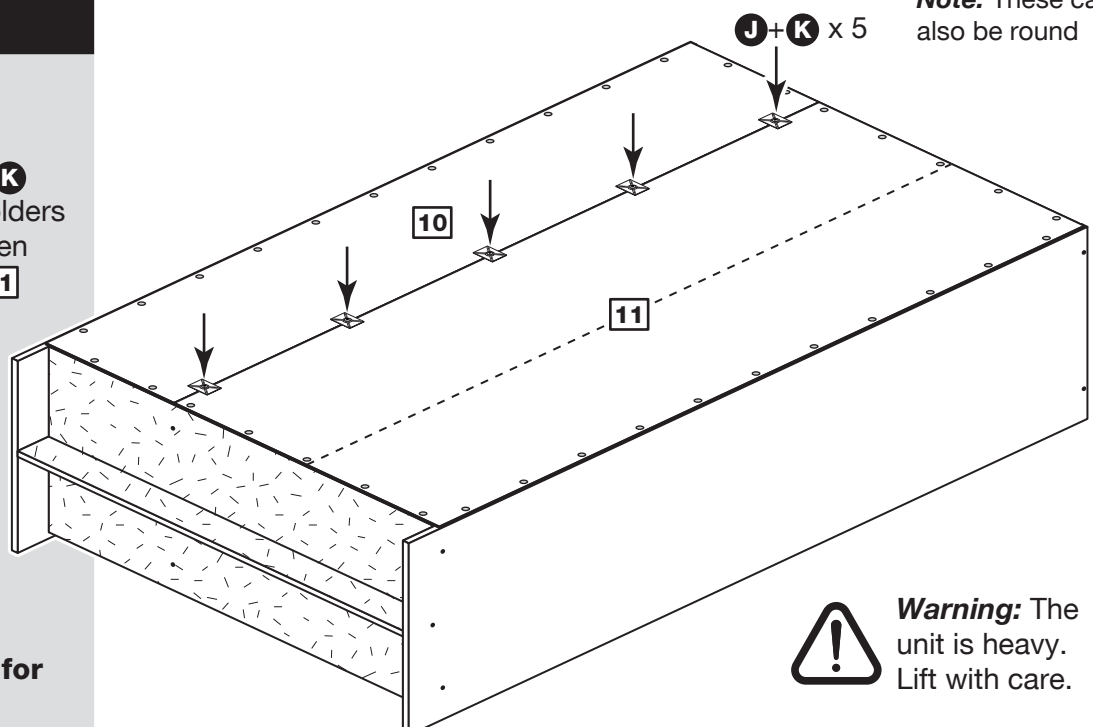

**Warning:** The unit is heavy. Lift with care.

# Assembly Instructions

## Step 12

### Fit the hanging rail and the shelves

Push hanging rail **8** into the rail holders **H** fitted to the side panels.

For each of the 2 shelves **7**, insert 4 shelf studs **L** at the required height.

Lower the 2 shelves **7** down onto the shelf studs **L**.

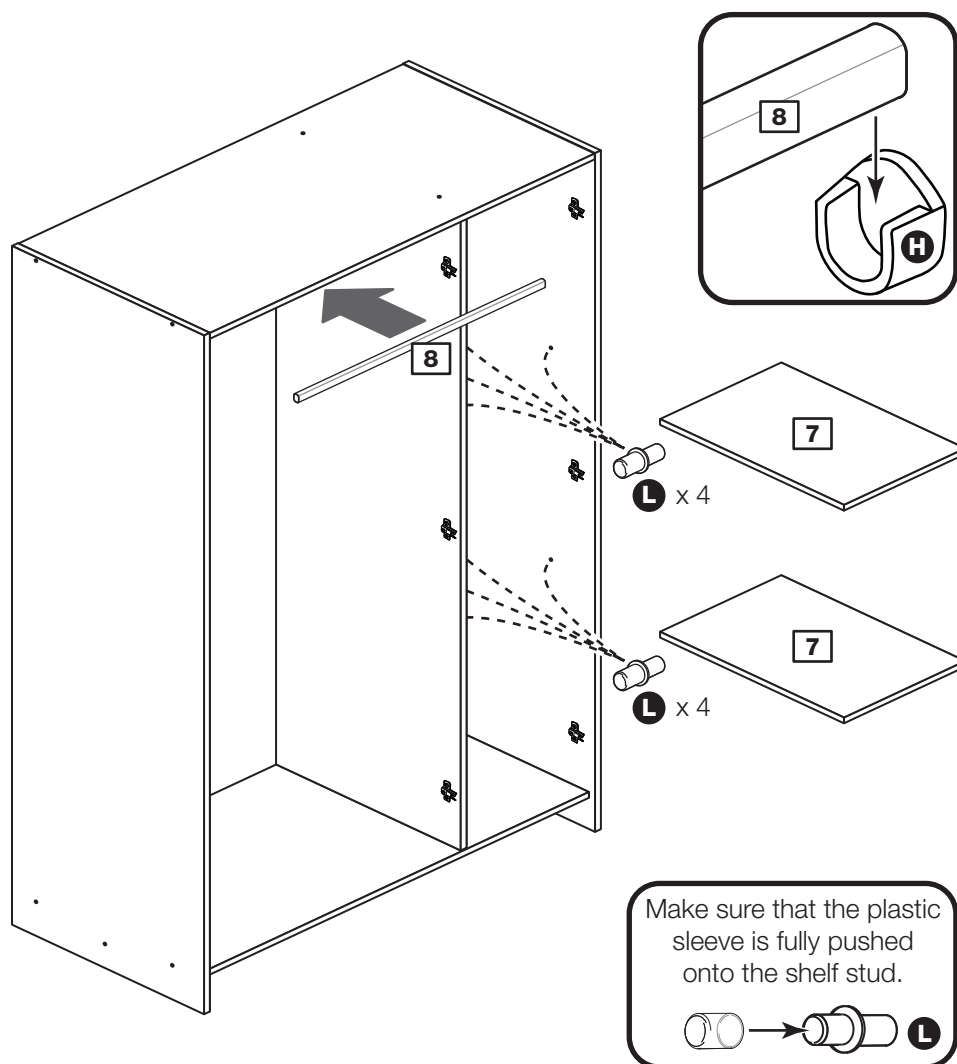

## Step 13

### Prepare the 3 doors

Push fit 3 hinges **N** into each of the the doors **9**.

Secure each hinge with 2 screws **F**.

**Note:** Before securing with the screws, make sure that the hinges are positioned at 90 degrees with the edge of the door.

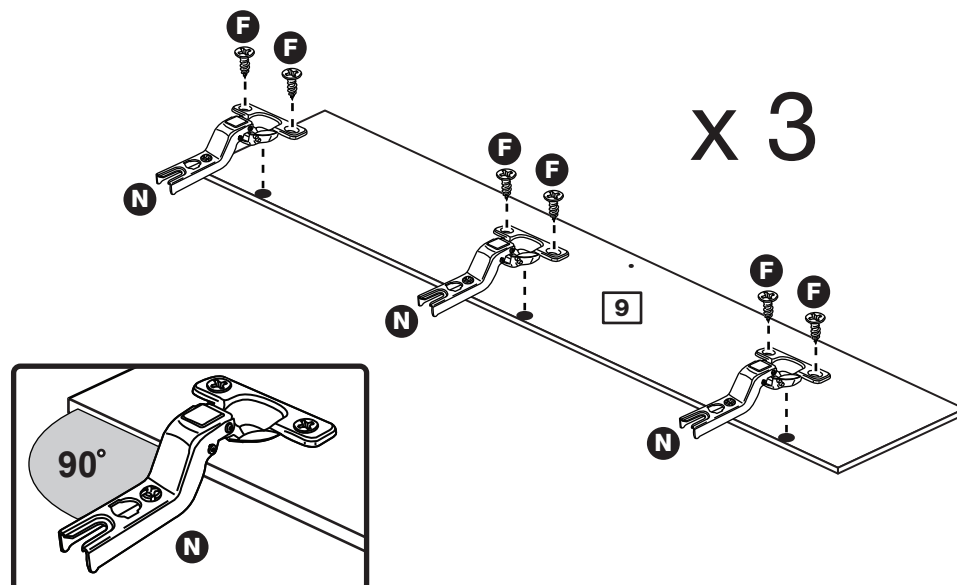

# Assembly Instructions

## Step 14

### Fit doors and handles

**Note:** The easiest way to attach each door **9** is to fit the top hinge first, then align and fit the other hinges.

**a:** Push the hinge **N** onto the front part of the hinge plate **M**. The recess at the bottom of screw B goes into the slot in the hinge plate.

**b:** Keep the hinge **N** FLAT against the hinge plate **M** as you slide it across as far as it will go. Tighten screw A.

**c:** The hinge **N** must be flat against the hinge plate **M** prior to any adjustment.

**d:** The hinge **N** must NOT be AT AN ANGLE to the hinge plate **M** when assembled. This would indicate that the recess at the bottom of screw B had not located in the slot in the hinge plate and the hinge would not be secure. Remove the hinge from the hinge plate and then re-assemble being careful to follow instructions a-c.

**e:** Attach a handle **I** to each door **9** using screw **D**.

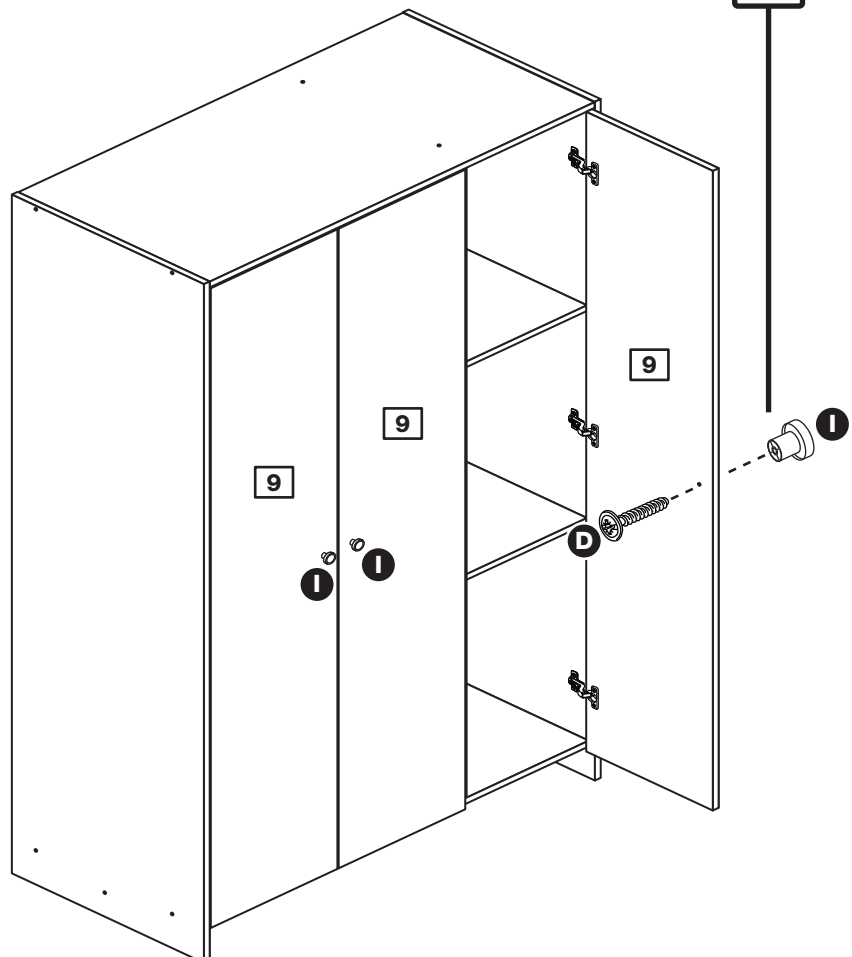
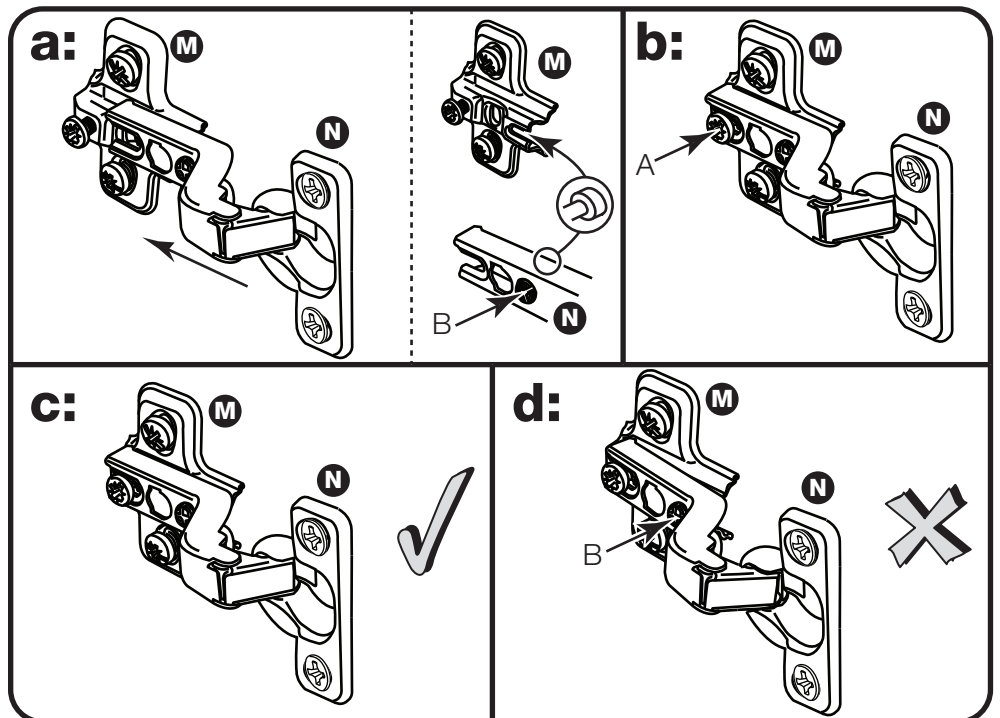

# Assembly Instructions

## Step 15

### Adjust the doors if needed

**a:** Before adjusting the doors, use a spirit level to check the base (or top) of the unit is level, front-to-back and side-to-side in the 3 positions shown. Use suitable packing pieces (not supplied) to make the unit level BEFORE making any adjustment to the hinges, as shown.

### **b:** Height adjustment.

Loosen screws A on hinge plates and move door up or down as required. Retighten screw A.

### **c:** Forward and Back adjustment.

Loosen screw B on hinge plate and move door in or out as required. Retighten screw B.

### **d:** Sideways adjustment.

To move door 'out' loosen screw C. To move door 'in' tighten screw C.

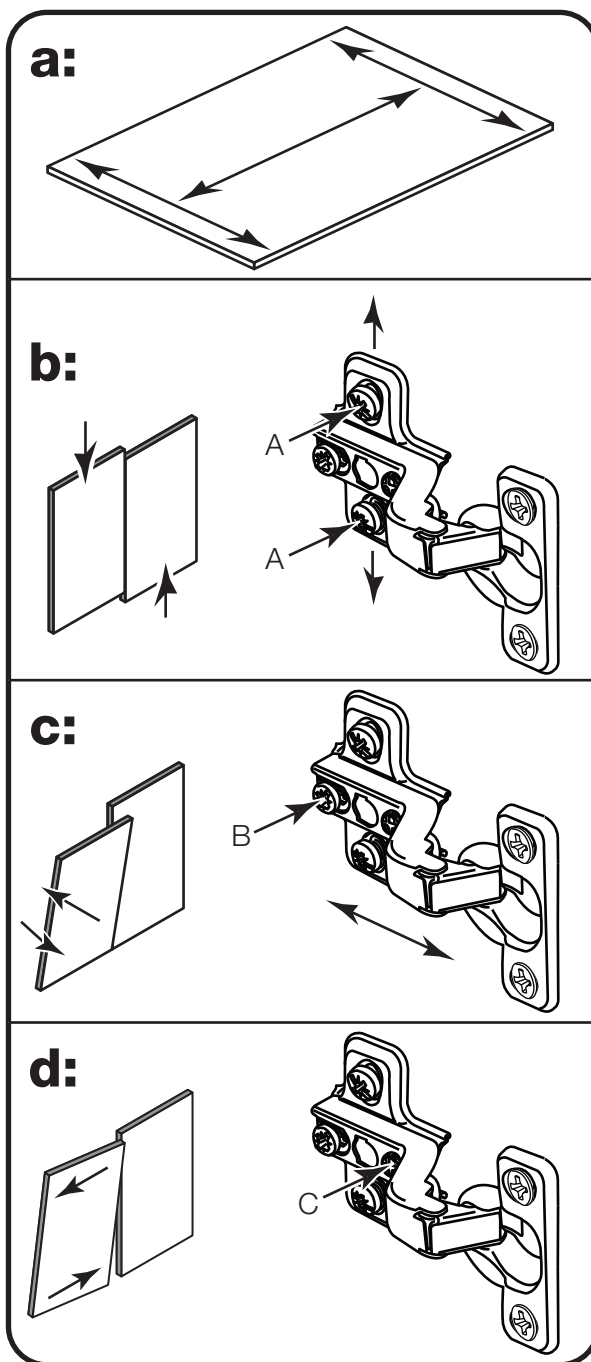



# Assembly Instructions

## Step 16

### Fit the bracket

To prevent possible overbalancing, we recommend that this unit is secured to a suitable wall by use of the bracket **G** fitted to the top of the unit.

Fixings are not supplied, as they will need to suit the wall type and the length of screw will depend on the distance from the back of the unit to the wall.

Fix the bracket **G** loosely onto the top of the unit using screw **E** and mark the wall for the wall fixing.

Swivel the bracket **G** away from the wall and drill a hole in the wall using a suitable drill bit and fit your wall fixing.

Swivel the bracket **G** back and fix the bracket to the wall, then tighten Screw **E**.

**Note:** Take care when drilling the wall that you do not drill into any pipes, wires etc. If in doubt, consult an expert.



**Warning:** The unit is heavy. Lift with care.

**Assembly is complete**

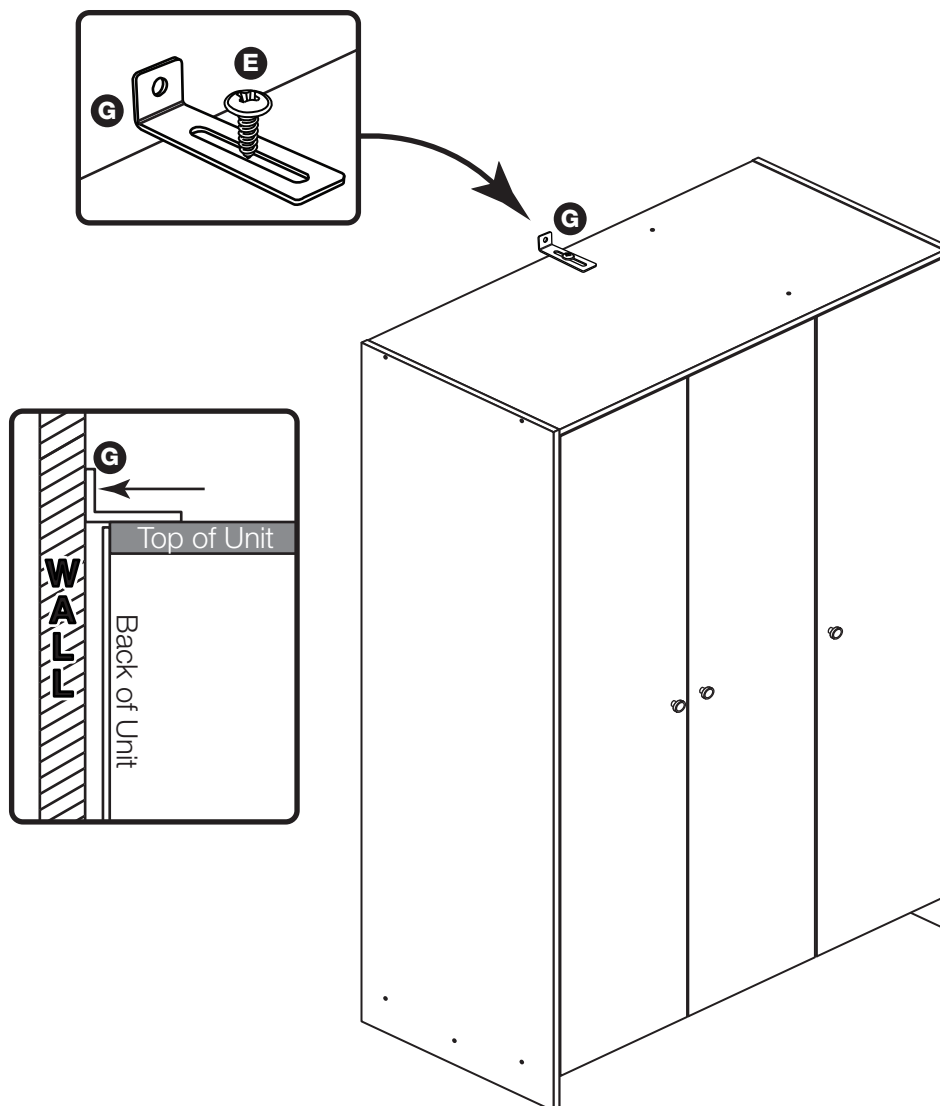

If you need help or have damaged or missing parts, call the **Customer Helpline: 0870 112 1928** or email: [Help@ClickSpares.co.uk](mailto:Help@ClickSpares.co.uk) (quoting your original order number and the reference numbers on the component pages)  
Argos Ltd, 489-499 Avebury Boulevard, Central Milton Keynes, MK9 2NW







# Seville - 3 Door Robe

Assembly Instructions - Please keep for future reference

147/4556

171/6939

167/8338

173/6146

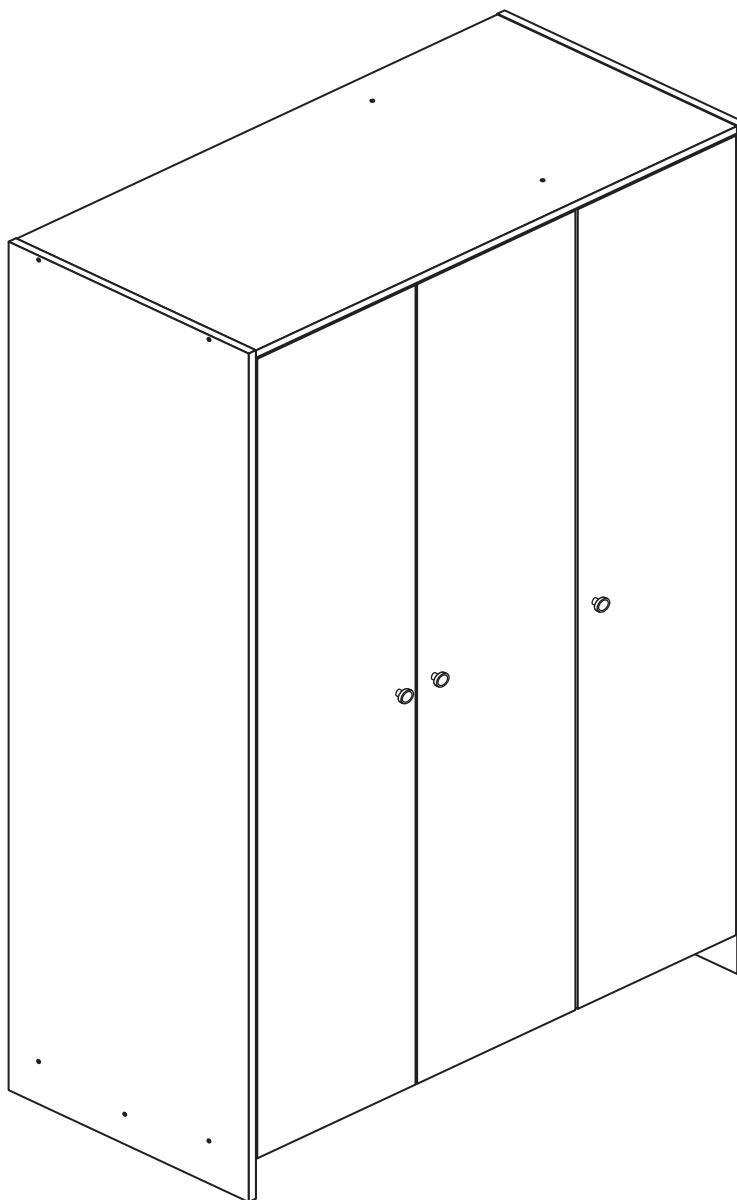

## Dimensions

Width - 102.5cm

Depth - 49.5cm

Height - 175.5cm



**MADE IN  
BRITAIN**

**Important** - Please read these instructions fully before starting assembly

If you need help or have damaged or missing parts, call the **Customer Helpline: 0870 112 1928** or email: [Help@ClickSpares.co.uk](mailto:Help@ClickSpares.co.uk) (quoting your original order number)



# Safety and Care Advice

**Important - Please read these instructions fully before starting assembly**

- **Warning:** This unit weighs approximately 59kgs. Please lift with care.

- Check you have all the components and tools listed on pages 2 and 3.

- Remove all fittings from the plastic bags and separate them into their groups.

- Keep children and animals away from the work area, small parts could choke if swallowed.

- Parts of the assembly will be easier with 2 people.

- Make sure you have enough space to layout the parts before starting.

- Do not stand or put weight on the product, this could cause damage.

- Assemble the item as close to its final position (in the same room) as possible.

- Assemble on a soft level surface to avoid damaging the unit or your floor (use opened out unit carton).



- We do not recommend the use of power drill/drivers **for inserting screws**, as this could damage the unit. Only use hand screwdrivers.

- **Safety note:** It is recommended that this unit is secured to a wall using the overbalance protector kit supplied or, an alternative fixing method of your choice.

- Dispose of all packaging carefully and responsibly.

## Care and maintenance

- Only clean using a damp cloth and mild detergent, do not use bleach or abrasive cleaners.

- From time to time check that there are no loose screws on this unit.

- This product should not be discarded with household waste. Take to your local authority waste disposal centre.

**Note:** If required the next page can be cut out and used as reference throughout the assembly. Keep this page with these instructions for future reference.

# Components - Panels

If you have damaged or missing components, call the **Customer Helpline: 0870 112 1928** or email: **Help@ClickSpares.co.uk** (quoting your original order number and the reference numbers below)

Please check you have all the panels listed below

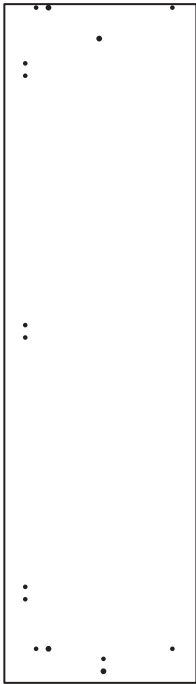

**1** Left Side (D2483A)  
(1753 x 496mm)

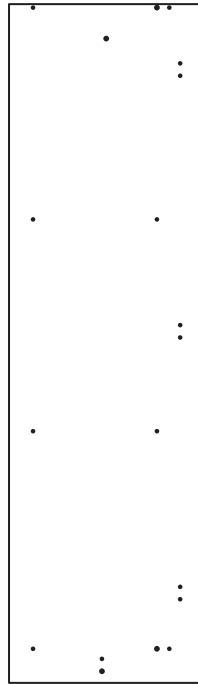

**2** Right Side (D2497A)  
(1753 x 496mm)

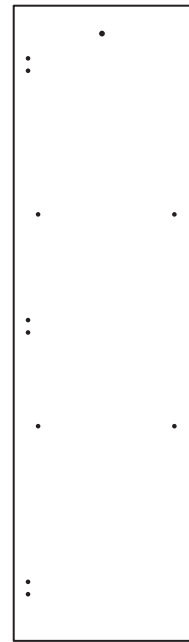

**3** Upright (D2500A)  
(1640.5 x 477mm)

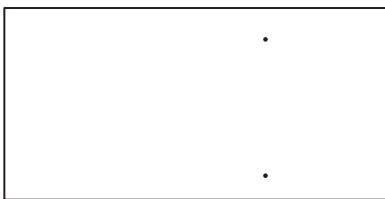

**4** Top (D2498A)  
(995 x 495mm)

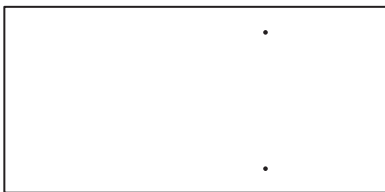

**5** Base (D2499A)  
(995 x 480mm)



**6** Plinth (D2502A)  
(995 x 80mm)



**7** Shelf (D2501A)  
(313 x 475mm) x 2



**8** Hanging Rail (FHR659)  
(659mm long)

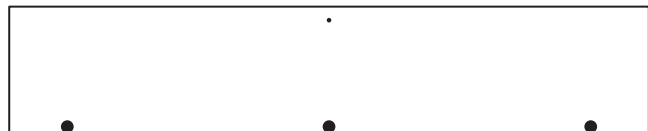

**9** Door (D2487A)  
(1652 x 327mm) x 3

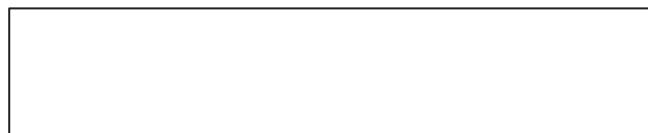

**10** Small Back (X1666-332)  
(1666 x 332mm)

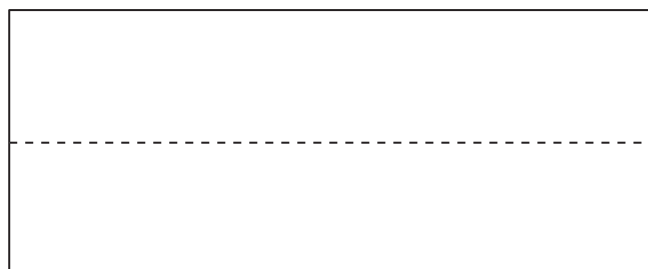

**11** Large Back (X1666-685)  
(1666 x 685mm)











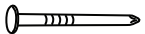

# Components - Fittings

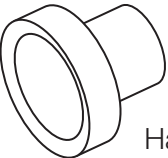
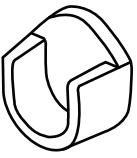
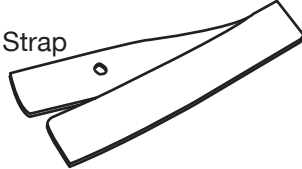



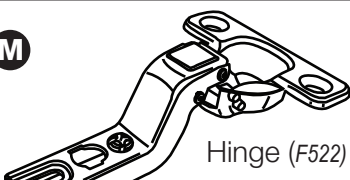

If you have damaged or missing components, call the **Customer Helpline: 0870 112 1928** or **email: Help@ClickSpares.co.uk** (quoting your original order number and the reference numbers below)

Please check you have all the fittings listed below

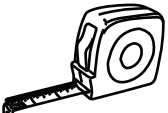
**Note:** The quantities below are the correct amount to complete the assembly. In some cases more fittings may be supplied than are required.

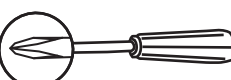
<p><b>A</b> </p> <p>Wooden dowel (F22) x 6</p>	<p><b>B</b> </p> <p>Nail (F51) x 36</p>	<p><b>C</b> </p> <p>40mm Screw (F910) x 14</p>
<p><b>D</b> </p> <p>25mm Screw (F95) x 3</p>	<p><b>E</b> </p> <p>Shelf support (F121) x 8</p>	<p><b>F</b> </p> <p>13mm Screw (F63) x 20</p>
<p><b>G</b> </p> <p>Handle (F300) x 3</p>	<p><b>H</b> </p> <p>Rail holder (F1014) x 2</p>	<p><b>I</b> </p> <p>Strap</p> <p> Screw  Washer x 2</p> <p>Overbalance protector kit (F269) x 1</p>
<p><b>J</b> </p> <p>Back holder (F276) x 5</p> <p><b>*These can also be round</b></p>	<p><b>K</b> </p> <p>Nail screw (F277) x 5</p>	
<p><b>L</b> </p> <p>Hinge plate (F523) x 9</p>	<p><b>M</b> </p> <p>Hinge (F522) x 9</p>	<p><b>Important:</b> Always pair up the hinges with the hinge plates from the same bag. DO NOT mix them up.</p>

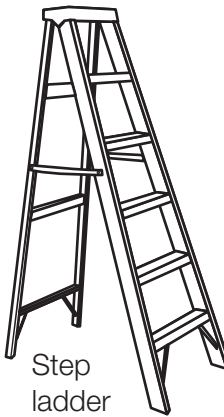
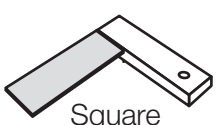
## Tools required

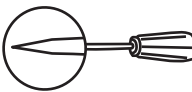
<p></p> <p>Rule</p>	<p></p> <p>Spirit level</p>	<p></p> <p>Eye protection (when using a hammer or drill)</p>	<p></p> <p>Cross-head screwdriver</p>	<p></p> <p>Electric drill (only use when drilling into walls)</p>	<p></p> <p>Step ladder</p>
<p></p> <p>Square</p>	<p></p> <p>Scissors</p>	<p></p> <p>Hammer</p>	<p></p> <p>Bradawl</p>		

**Ruler** - Use this ruler to help correctly identify the screws

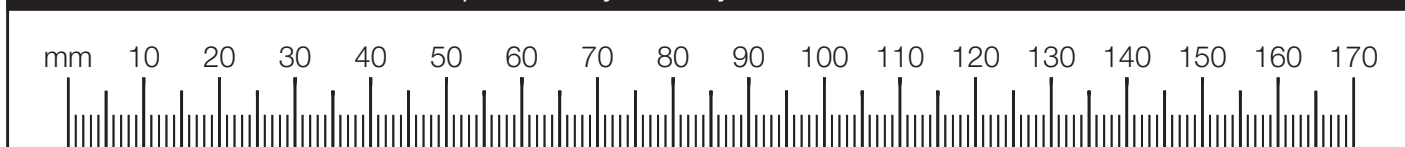



# Assembly Instructions

If you have damaged or missing components, call the Customer Helpline: 0870 112 1928 or email: [Help@ClickSpares.co.uk](mailto:Help@ClickSpares.co.uk) (quoting your original order number and the reference numbers below)

## Step 1

### Prepare the top and base

Tap 2 wooden dowels **A** into the top **4**.

Tap 2 wooden dowels **A** into the base **5**.

**Note:** Wooden dowels **must not** stick out from the edge by more than 10mm or they may damage other panels.

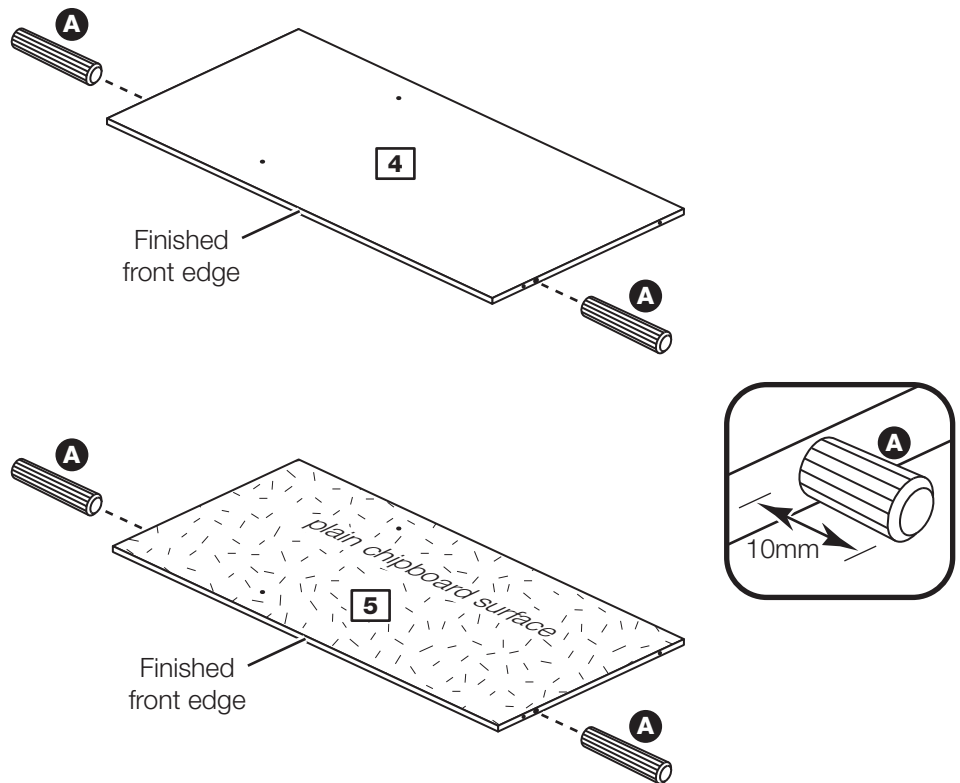

## Step 2

### Prepare the upright

Push a rail holder **H** into the upright **3**. Make sure that it is fitted straight, in line with the panel edges and then secure with screw **F**.

Fit 3 hinge plates **L** onto the upright **3**, making sure that the slot is facing towards the finished front edge.

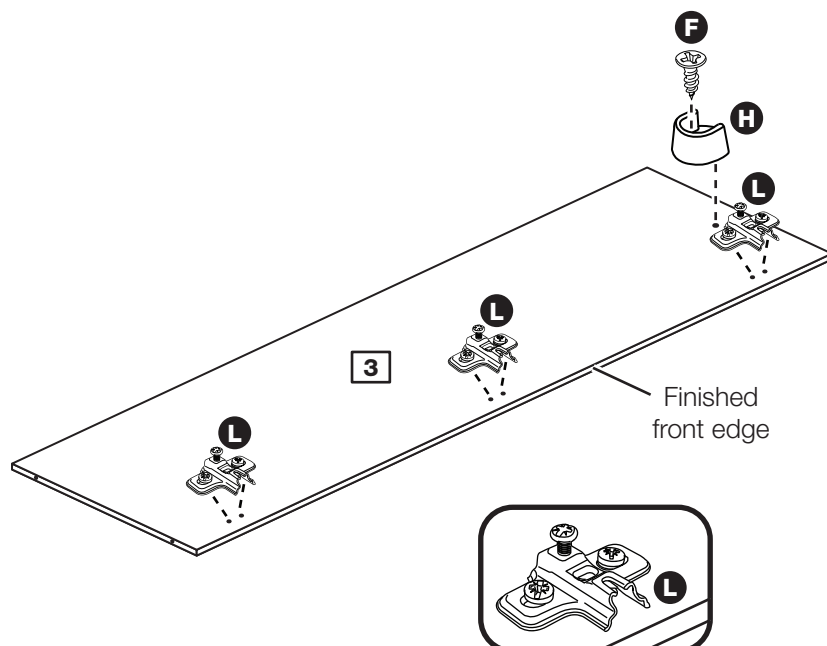

# Assembly Instructions

## Step 3

### Fit the top and the base to the upright

Fit the top **4** and the base **5** onto the upright **3** using 4 screws **C**.

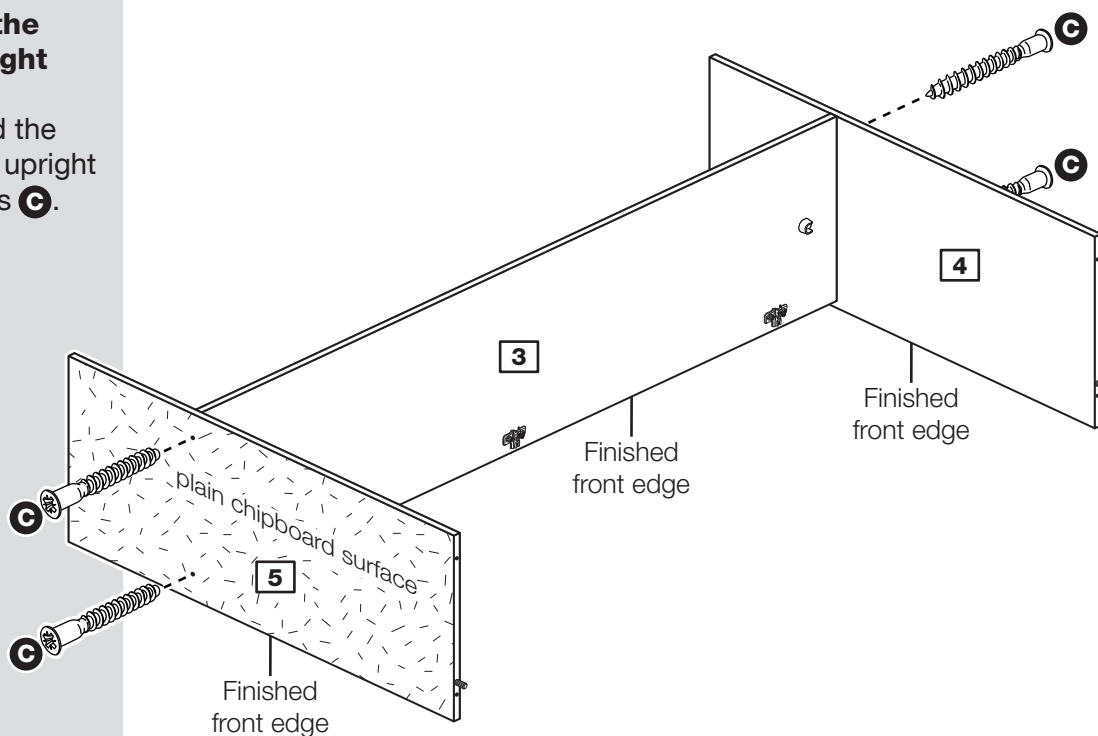

## Step 4

### Prepare the right side

Fit 3 hinge plates **L** onto the right side **2**, making sure that the slot is facing towards the finished front edge.

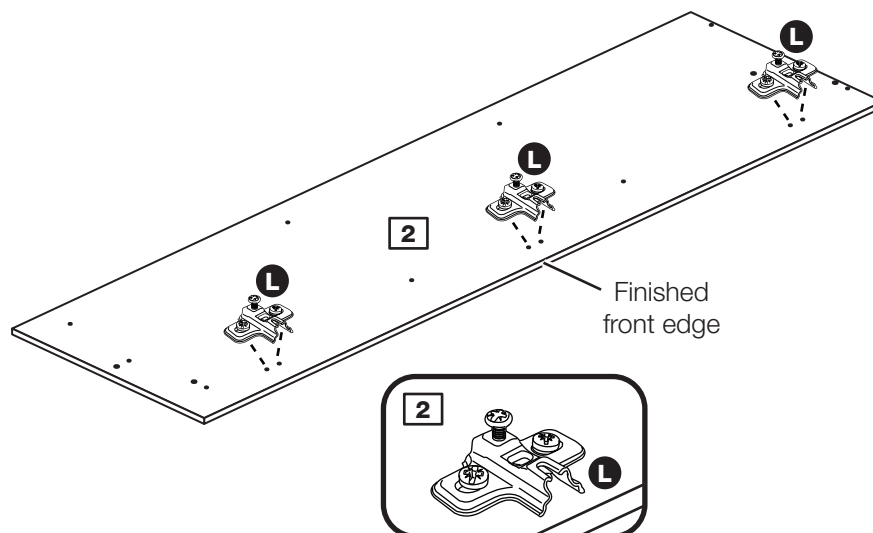

# Assembly Instructions

## Step 5

### Fit the right side

Push the right side **2** onto the top **4** and base **5** and secure it using 4 screws **C**.

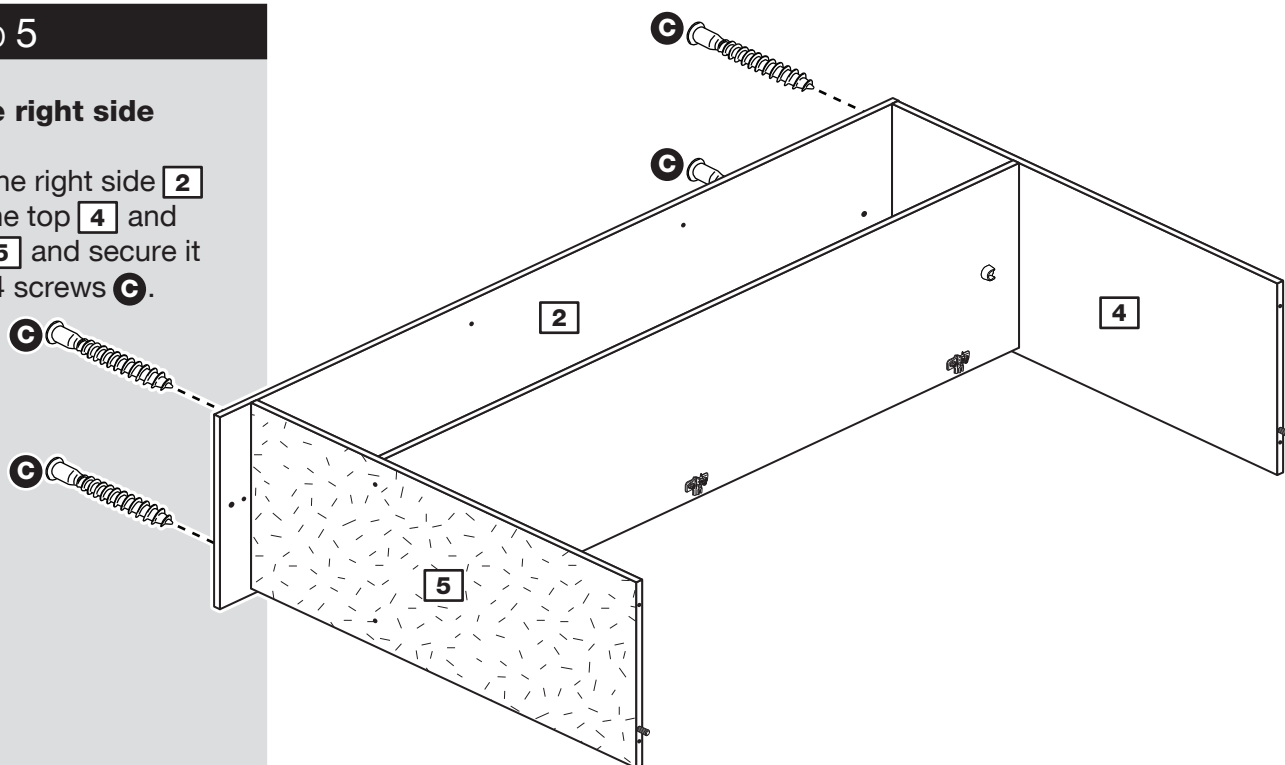

## Step 6

### Prepare the plinth

Tap 2 wooden dowels **A** into the plinth **6**.

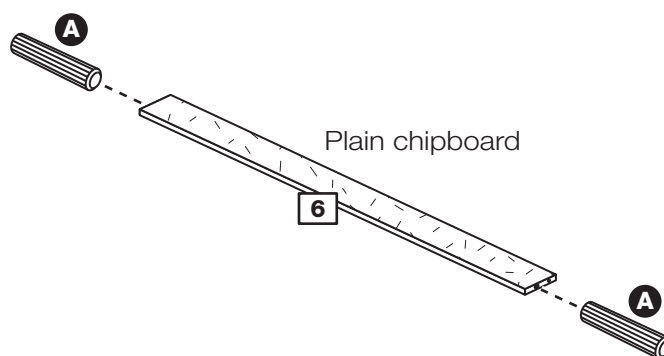

## Step 7

### Prepare the left side

Push a rail holder **H** into the left side **1**. Make sure that it is fitted straight, in line with the panel edges and then secure with screw **F**.

Fit 3 hinge plates **L** onto the left side **1**, making sure that the slot is facing towards the finished front edge.

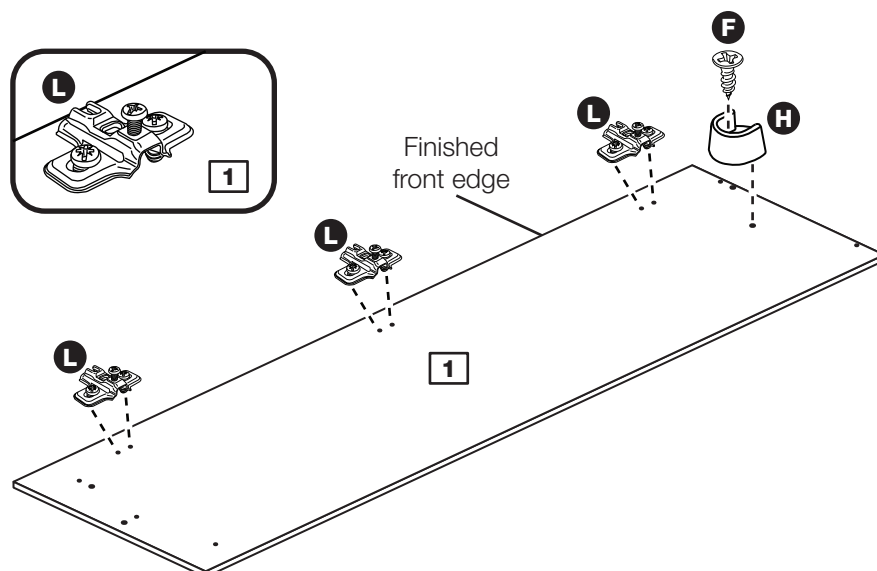

# Assembly Instructions

## Step 8

### Fit the plinth

Push the plinth **6** onto the right side **2** and secure it using screw **C**.

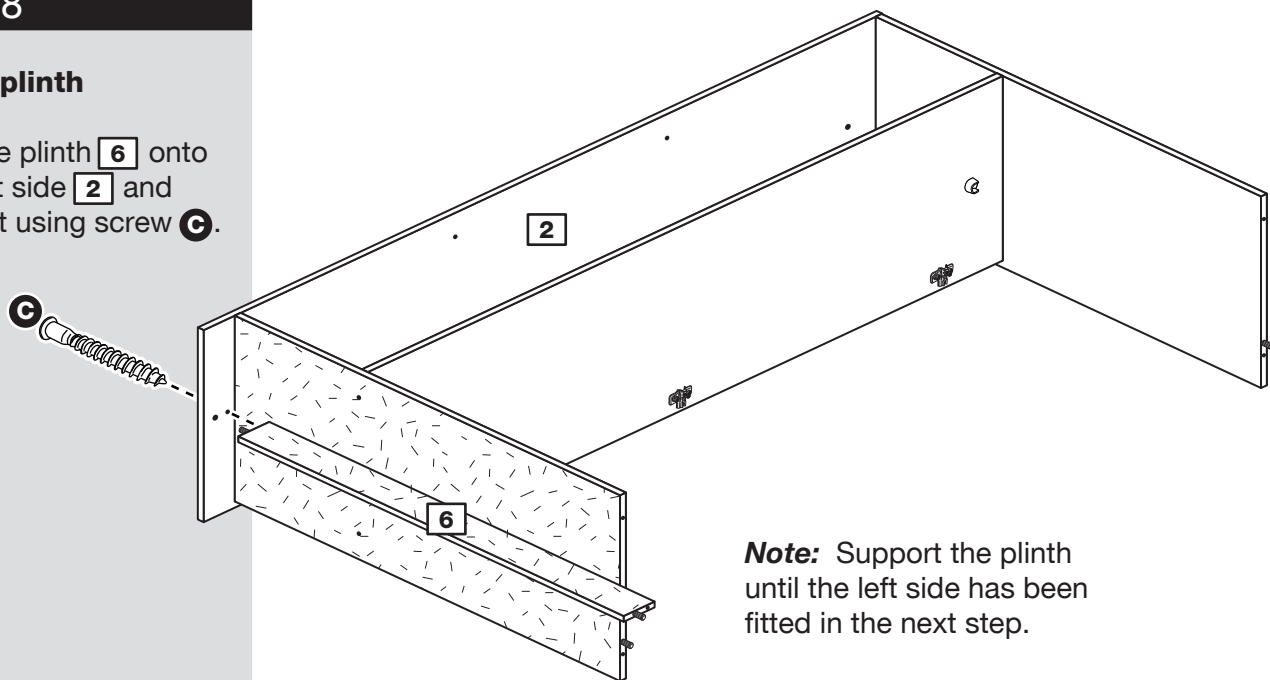

**Note:** Support the plinth until the left side has been fitted in the next step.

## Step 9

### Fit the left side

Push the left side **1** onto the assembly and secure it using 5 screws **C**.

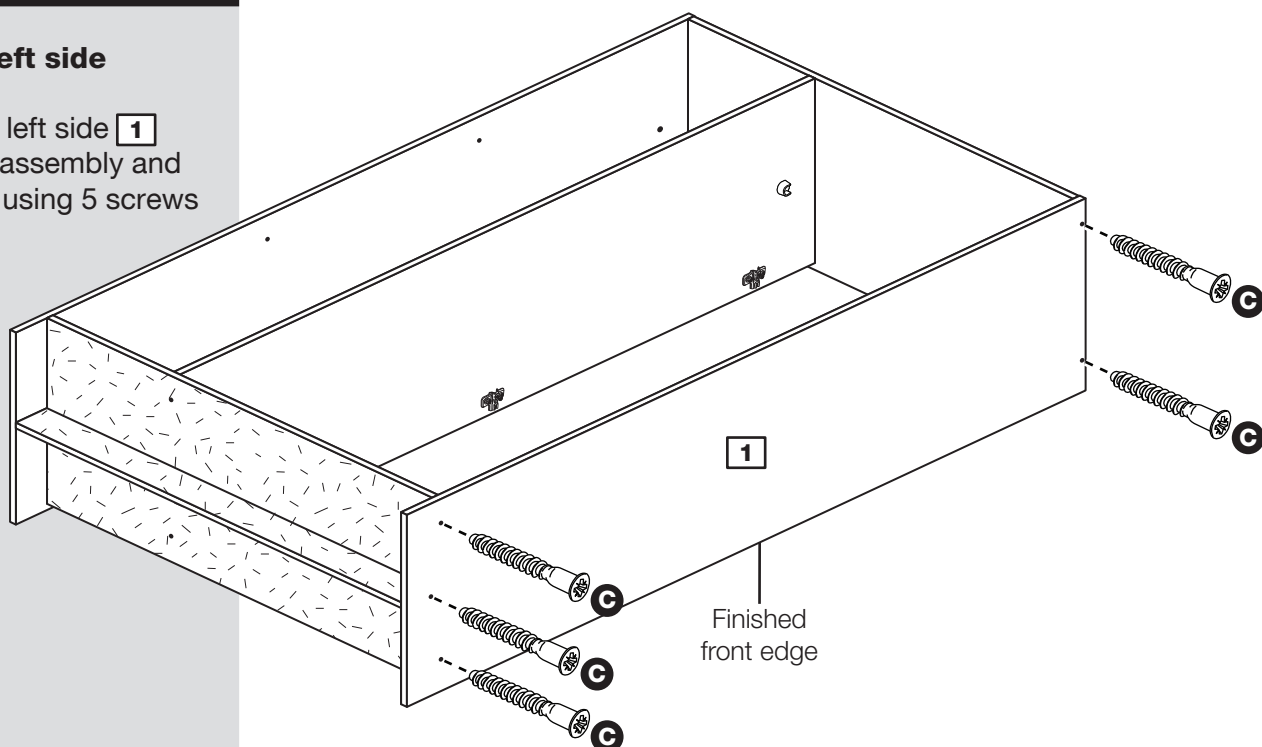

# Assembly Instructions

## Step 10

### Fit the back

**a:** Square up the unit by making sure that measurement **x** to **x** equals **y** to **y**.

Place the small back **10** and large back **11** down onto the unit as shown.

Make sure that the 2 backs are pushed up tight against each other and that they meet over the back edge of the upright.

**b:** Nail **B** around the outside edges of the 2 backs.

**Note:** Do not nail where the backs meet. Nails should be spaced about 150mm apart.

**a:** The measurement from top corner X to bottom corner X must be equal to the measurement from top corner Y to bottom corner Y

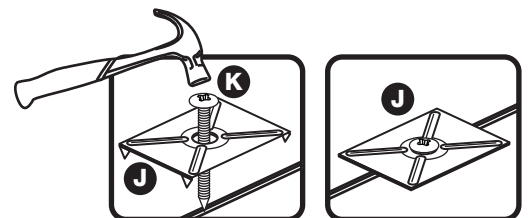
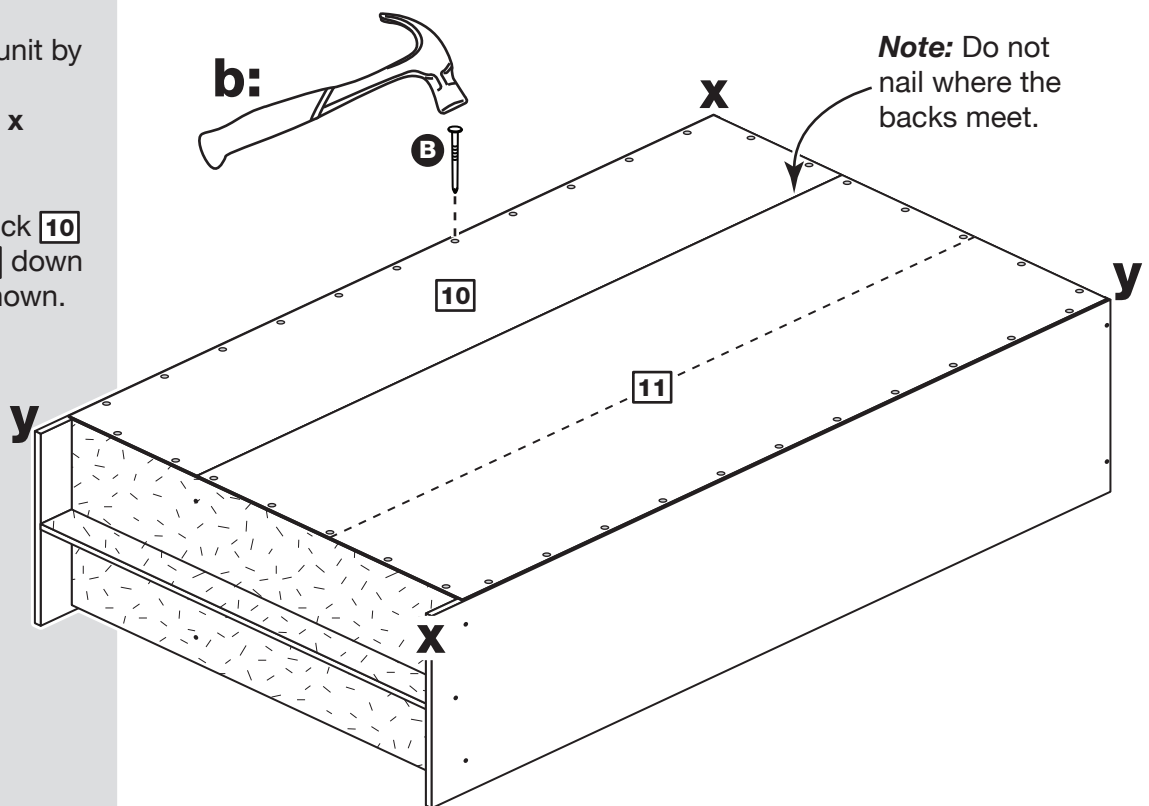

**Note:** These can also be round

## Step 11

### Secure the backs

Tap the nail screws **K** through the back holders **J** and down between the backs **10** and **11** into the back edge of the divider.

Keep tapping the nail screws **K** in until the back holders **J** dig into the small and large back.

**Stand the unit up for the next step.**

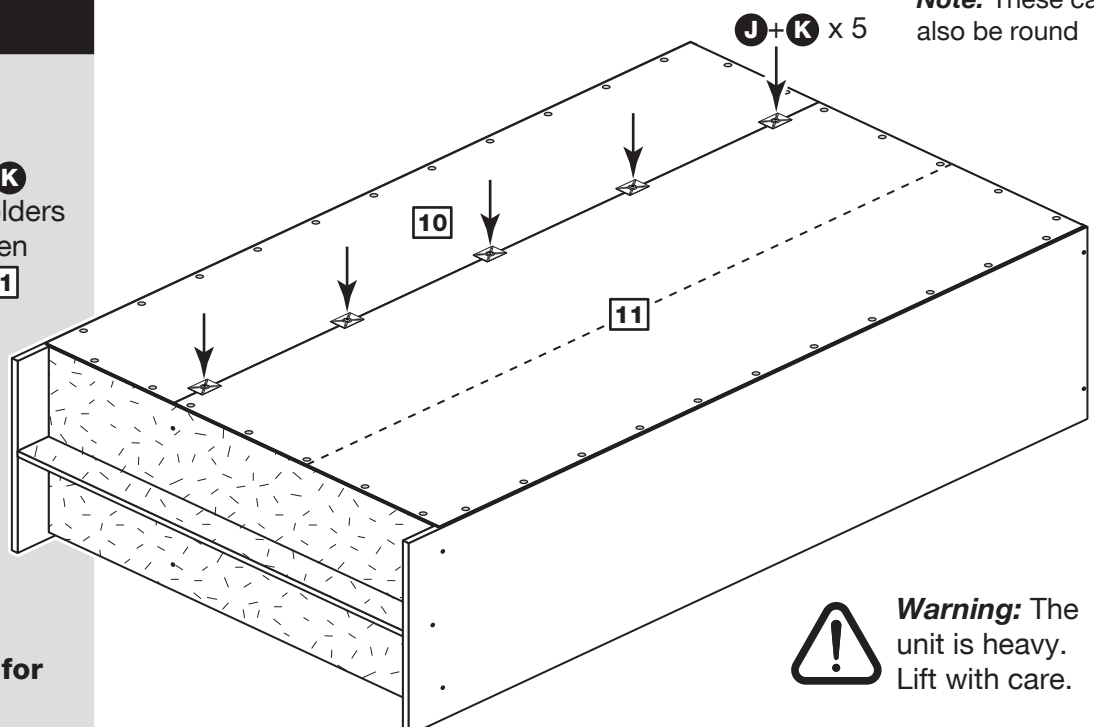

**Warning:** The unit is heavy. Lift with care.

# Assembly Instructions

## Step 12

### Fit the hanging rail and the shelves

Push hanging rail **8** into the rail holders **H** fitted to the side panels.

For each of the 2 shelves **7**, insert 4 shelf studs **E** at the required height.

Lower the 2 shelves **7** down onto the shelf studs **L**.

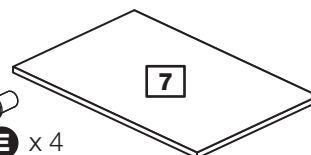
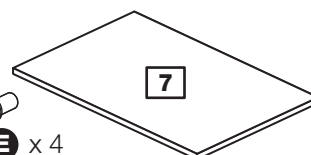
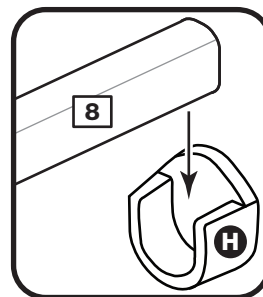
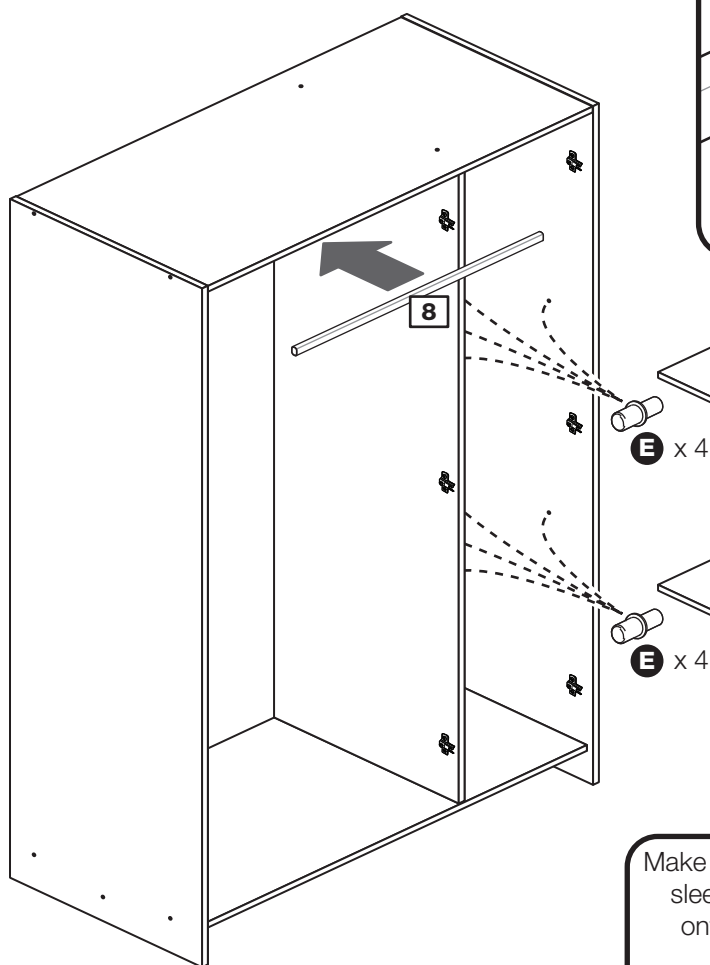

Make sure that the plastic sleeve is fully pushed onto the shelf stud.



## Step 13

### Prepare the 3 doors

Push fit 3 hinges **M** into each of the the doors **9**.

Secure each hinge with 2 screws **F**.

**Note:** Before securing with the screws, make sure that the hinges are positioned at 90 degrees with the edge of the door.

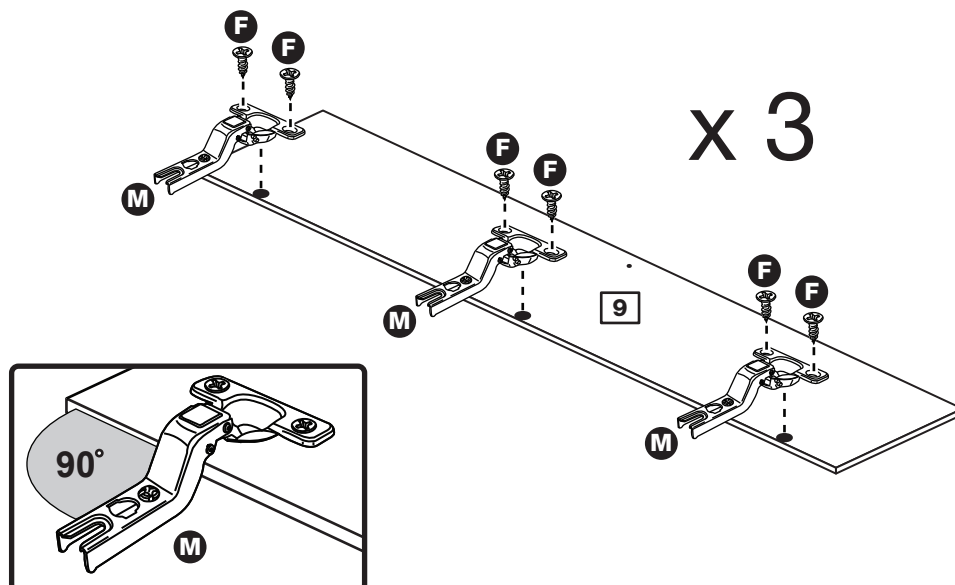

# Assembly Instructions

## Step 14

### Fit doors and handles

**Note:** The easiest way to attach each door **9** is to fit the top hinge first, then align and fit the other hinges.

**a:** Push the hinge **M** onto the front part of the hinge plate **L**. The recess at the bottom of screw B goes into the slot in the hinge plate.

**b:** Keep the hinge **M** FLAT against the hinge plate **L** as you slide it across as far as it will go. Tighten screw A.

**c:** The hinge **M** must be flat against the hinge plate **L** prior to any adjustment.

**d:** The hinge **M** must NOT be AT AN ANGLE to the hinge plate **L** when assembled. This would indicate that the recess at the bottom of screw B had not located in the slot in the hinge plate and the hinge would not be secure. Remove the hinge from the hinge plate and then re-assemble being careful to follow instructions a-c.

**e:** Attach a handle **G** to each door **9** using screw **D**.

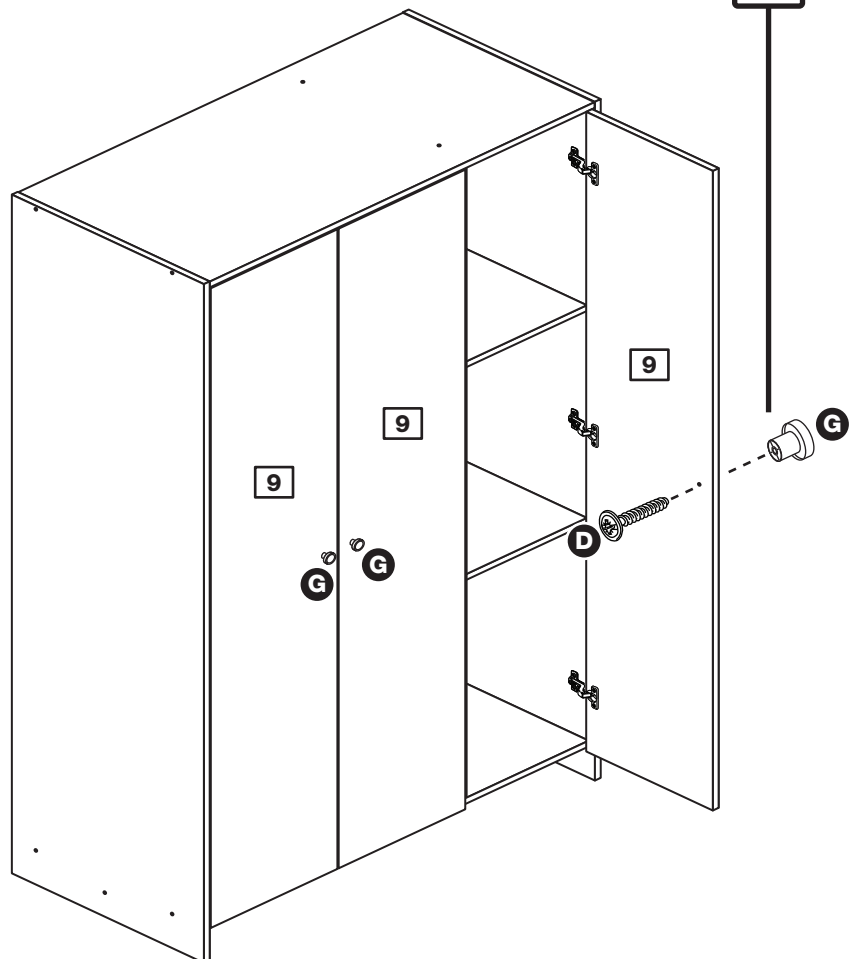
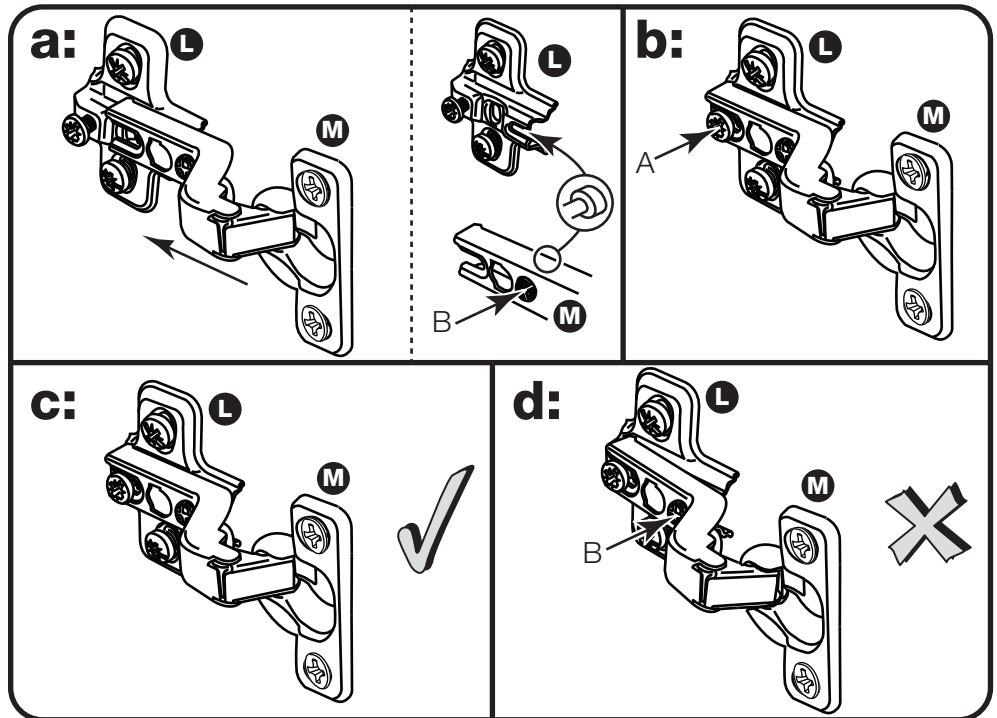

# Assembly Instructions

## Step 15

### Adjust the doors if needed

**a:** Before adjusting the doors, use a spirit level to check the base (or top) of the unit is level, front-to-back and side-to-side in the 3 positions shown. Use suitable packing pieces (not supplied) to make the unit level BEFORE making any adjustment to the hinges, as shown.

### **b:** Height adjustment.

Loosen screws A on hinge plates and move door up or down as required. Retighten screw A.

### **c:** Forward and Back adjustment.

Loosen screw B on hinge plate and move door in or out as required. Retighten screw B.

### **d:** Sideways adjustment.

To move door 'out' loosen screw C. To move door 'in' tighten screw C.

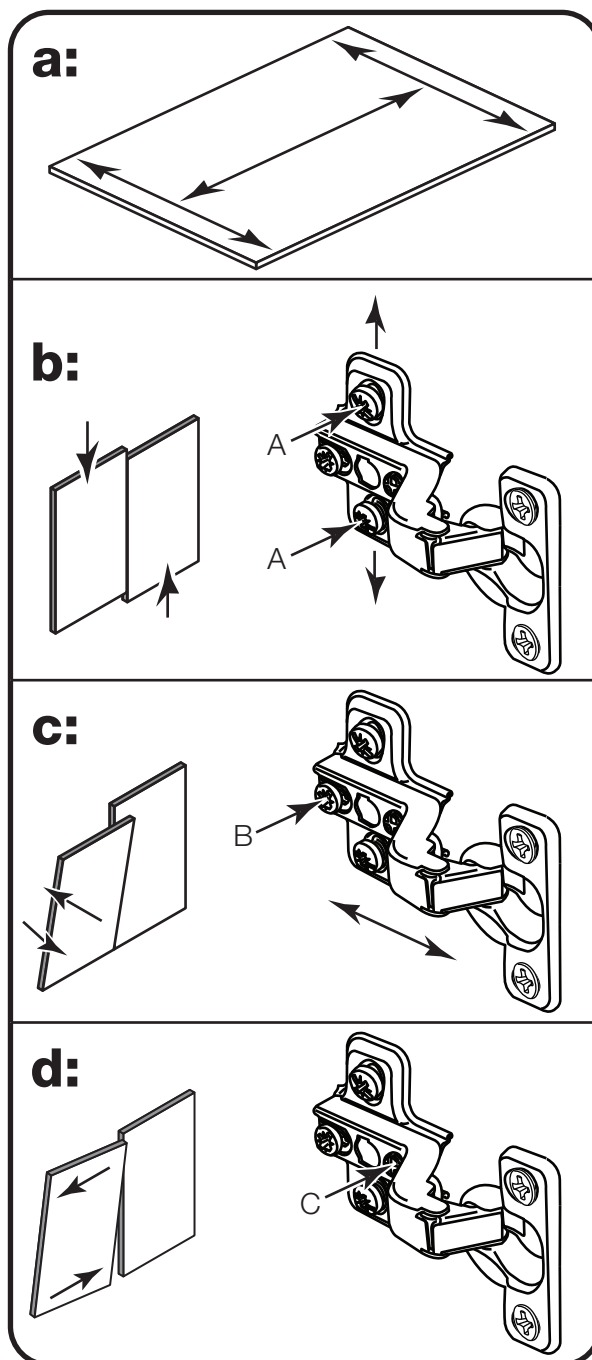



# Assembly Instructions

## Step 16

### Fit the overbalance protector kit

To prevent possible overbalancing we recommend that this unit is secured to a suitable wall by fitting of the overbalance protector kit ❶ to the unit, or an alternative fixing method of your choice.

Wall fixings are not supplied as they will need to suit the wall type.

**Note:** Take care when drilling the wall that you do not drill into any pipes, wires etc. If in doubt, consult an expert.

**Assembly is complete**

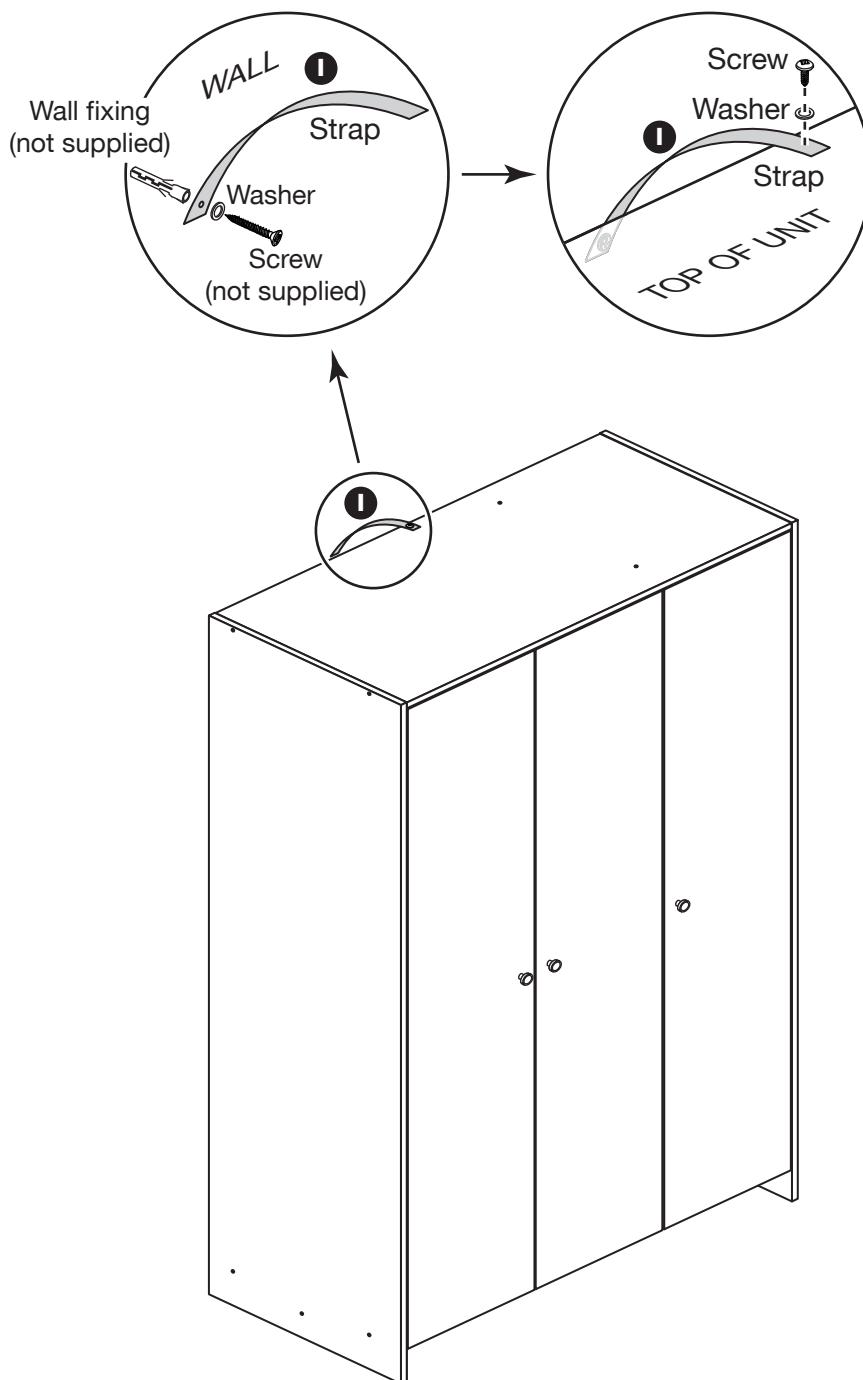

If you need help or have damaged or missing parts, call the **Customer Helpline: 0870 112 1928** or email: [Help@ClickSpares.co.uk](mailto:Help@ClickSpares.co.uk) (quoting your original order number and the reference numbers on the component pages)  
Argos Ltd, 489-499 Avebury Boulevard, Central Milton Keynes, MK9 2NW







# Seville - 5 Drawer Chest

Assembly Instructions - Please keep for future reference

184/9198

189/6385

145/0862

184/8319

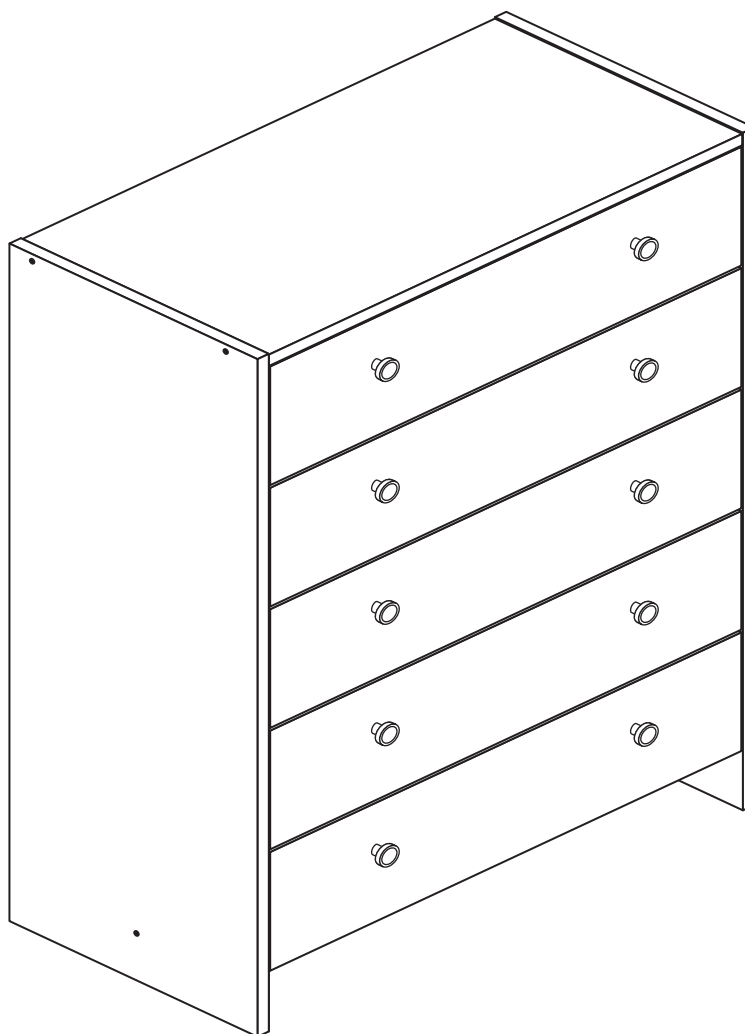

## Dimensions

Width - 66cm

Depth - 33cm

Height - 91cm



**MADE IN  
BRITAIN**

**Important** - Please read these instructions fully before starting assembly

If you need help or have damaged or missing parts, call the **Customer Helpline: 0870 112 1928** or email: [Help@ClickSpares.co.uk](mailto:Help@ClickSpares.co.uk) (quoting your original order number)



# Safety and Care Advice

**Important - Please read these instructions fully before starting assembly**

- **Warning:** This unit weighs approximately 21kgs. Please lift with care.

- Check you have all the components and tools listed on pages 2 and 3.

- Remove all fittings from the plastic bags and separate them into their groups.

- Keep children and animals away from the work area, small parts could choke if swallowed.

- Parts of the assembly will be easier with 2 people.

- Make sure you have enough space to layout the parts before starting.

- Do not stand or put weight on the product, this could cause damage.

- Assemble the item as close to its final position (in the same room) as possible.

- Assemble on a soft level surface to avoid damaging the unit or your floor (use opened out unit carton).



- We do not recommend the use of power drill/drivers **for inserting screws**, as this could damage the unit. Only use hand screwdrivers.

- **Safety note:** It is recommended that this unit is secured to a wall using the bracket supplied.

- Dispose of all packaging carefully and responsibly.

## Care and maintenance

- Only clean using a damp cloth and mild detergent, do not use bleach or abrasive cleaners.

- From time to time check that there are no loose screws on this unit.

- This product should not be discarded with household waste. Take to your local authority waste disposal centre.

**Note:** If required the next page can be cut out and used as reference throughout the assembly. Keep this page with these instructions for future reference.

# Components - Panels

If you have damaged or missing components, call the **Customer Helpline: 0870 112 1928** or email: **Help@ClickSpares.co.uk** (quoting your original order number and the reference numbers below)

Please check you have all the panels listed below

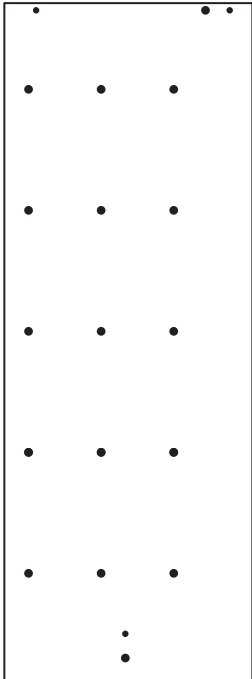

**1** Left Side (D2503A)  
(896 x 328mm)

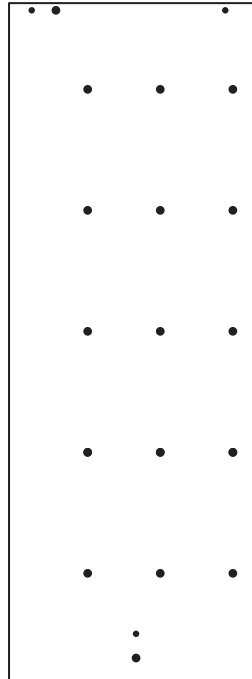

**2** Right Side (D2504A)  
(896 x 328mm)



**3** Top (D2488A)  
(627 x 327mm)



**4** Plinth (D2491A)  
(627 x 80mm)

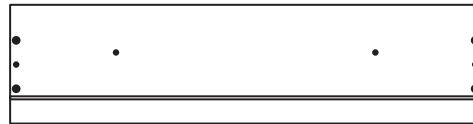

**5** Drawer Front (D2492A)  
(623 x 157mm) x 5

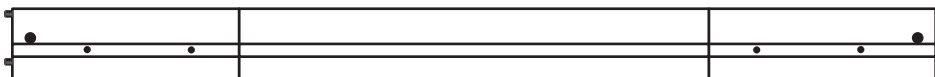

**6** Drawer Wrap (WSAV)  
(1221 x 95mm) x 5



**7** Drawer Base (TSAV)  
(299 x 608mm) x 5

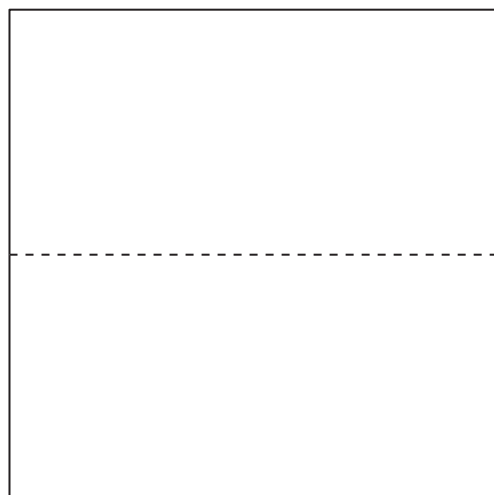

**8** Back (X653-648)  
(653 x 648mm)







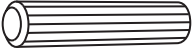
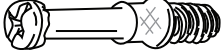

# Components - Fittings

If you have damaged or missing components, call the **Customer Helpline: 0870 112 1928** or **email: Help@ClickSpares.co.uk** (quoting your original order number and the reference numbers below)

Please check you have all the fittings listed below

**Note:** The quantities below are the correct amount to complete the assembly. In some cases more fittings may be supplied than are required.

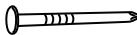
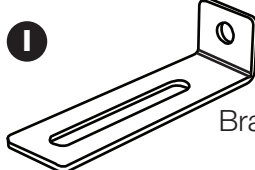
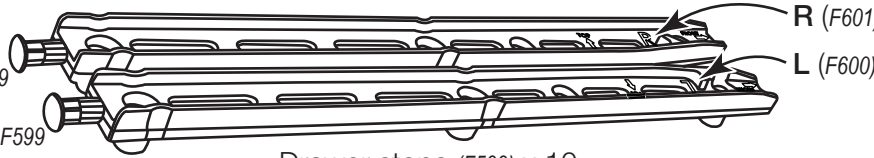
<p><b>A</b> </p> <p>Wooden dowel (F22) x 4</p>	<p><b>B</b> </p> <p>Metal dowel (F901) x 10</p>	<p><b>C</b> </p> <p>Small locking nut (F3) x 10</p>	
<p><b>D</b> </p> <p>40mm Screw (F910) x 6</p>	<p><b>E</b> </p> <p>25mm Screw (F95) x 10</p>	<p><b>F</b> </p> <p>13mm Screw (F79) x 1</p>	
<p><b>G</b> </p> <p>Handle (F300) x 10</p>	<p><b>H</b> </p> <p>Nail (F51) x 15</p>	<p><b>I</b> </p> <p>Bracket (F327) x 1</p>	
<p><b>J</b> </p> <p>Drawer stops (F599) x 10 Runners (F600) x 5 and (F601) x 5</p>			

## Tools required

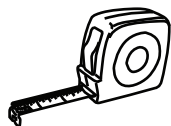

Rule



Cross-head screwdriver



Scissors



Hammer



Eye protection (when using a hammer or drill)

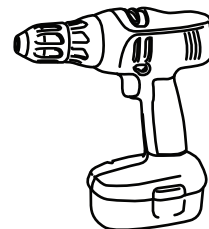

Electric drill (do not use for fitting screws)

## Ruler - Use this ruler to help correctly identify the screws

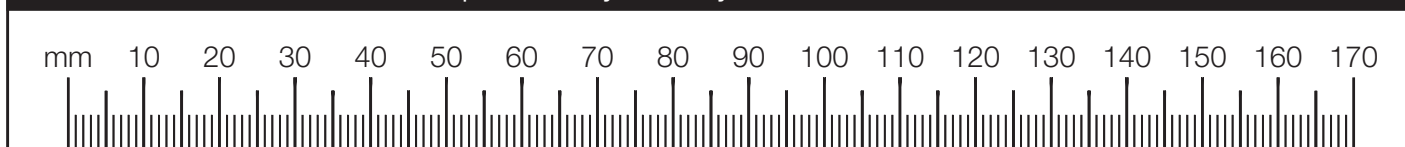



# Assembly Instructions

If you have damaged or missing components, call the Customer Helpline: 0870 112 1928 or email: [Help@ClickSpares.co.uk](mailto:Help@ClickSpares.co.uk) (quoting your original order number and the reference numbers below)

## Step 1

### Prepare the drawer fronts

Screw 2 metal dowels **B** into each of the drawer fronts **5**.

**Note:** Tighten the metal dowels up fully against the panel.

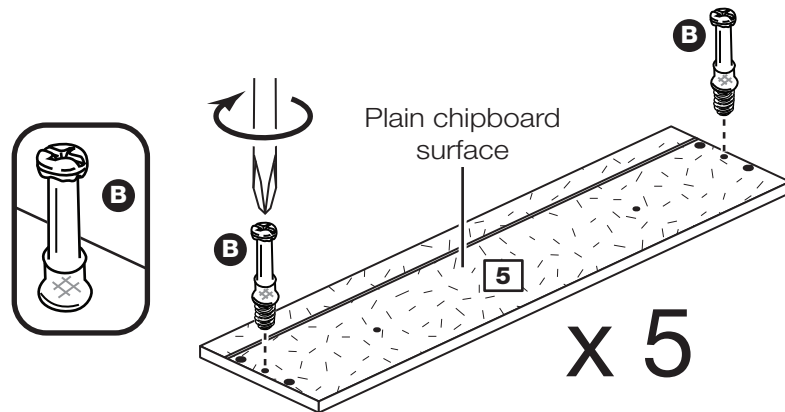

## Step 2

### Prepare the drawer wraps

Insert 2 small locking nuts **C** into each of the drawer wraps **6**.

**Note:** The arrow on the locking nut **must** point towards the hole in the edge of the panel.

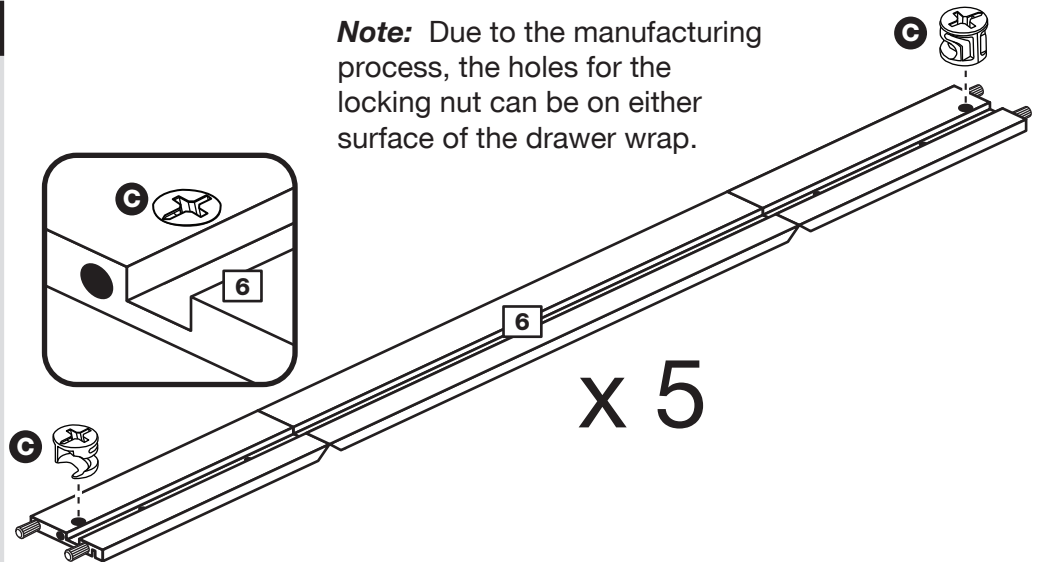

## Step 3

### Fit the drawer base

Place the drawer base **7** into the narrow slot on the drawer wrap **6**. Fold the wrap around the drawer base.

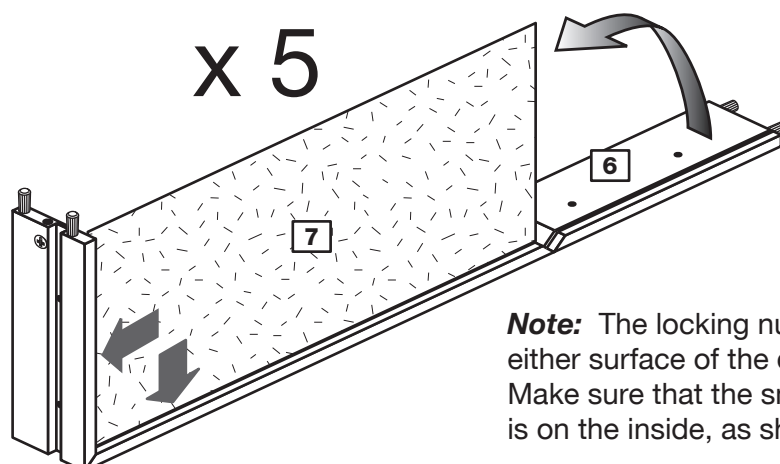

**Note:** The locking nuts can be on either surface of the drawer sides. Make sure that the small groove is on the inside, as shown.

# Assembly Instructions

## Step 4

### Fit the drawer front

Turn drawer wrap **6** assembly over and push it onto the back of the drawer front **5**.

**Note:** Turn the locking nuts **C** clockwise to secure the panels - more than 1/2 a turn.

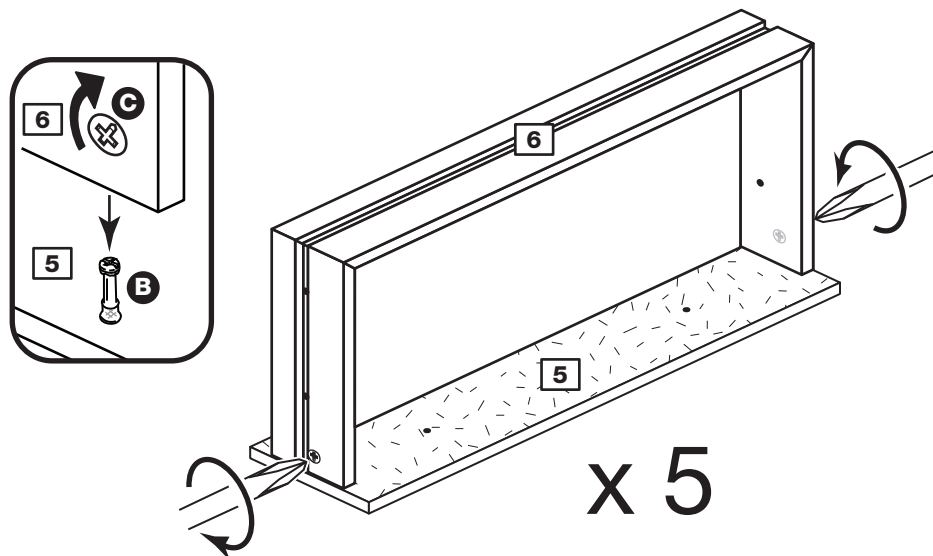

## Step 5

### Attach the drawer stops

Carefully break off 2 drawer stops (F599) from a set of drawer runners **J**.

Push the drawer stops fully through the drawer wrap **6** from the inside.

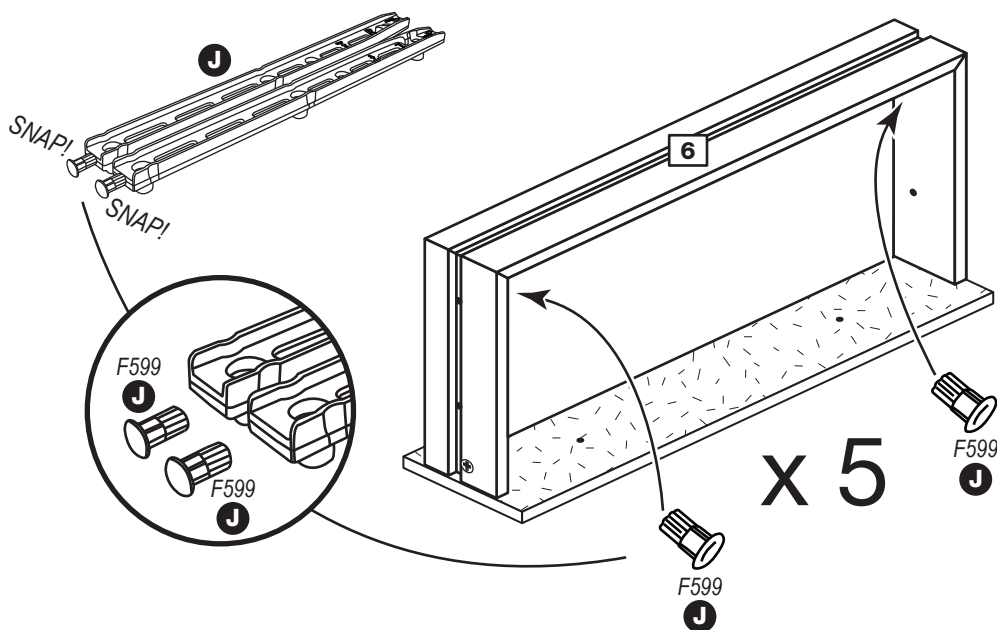

## Step 6

### Attach the handles

Attach 2 handles **G** to each of the 5 drawer fronts **5** using 2 screws **E**.

**Note:** Do not overtighten the screws.

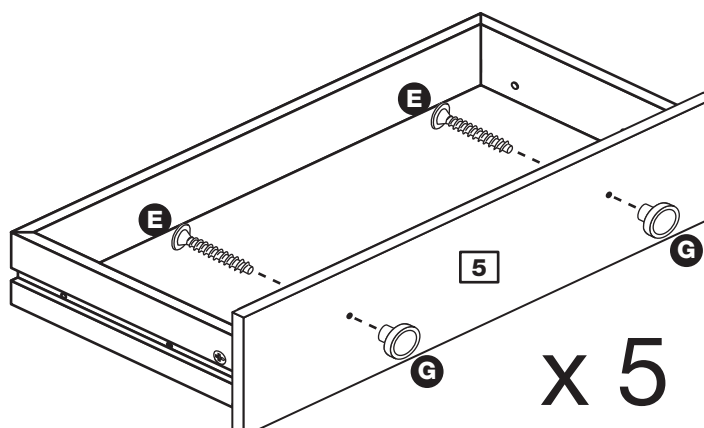

# Assembly Instructions

## Step 7

### Prepare the left side

Separate the runners **J**.

Push fit 5 left runners **J** marked 'L' into the left side **1**.

**Note:** Runners must be fitted flat against the panel. If necessary gently tap into final position.

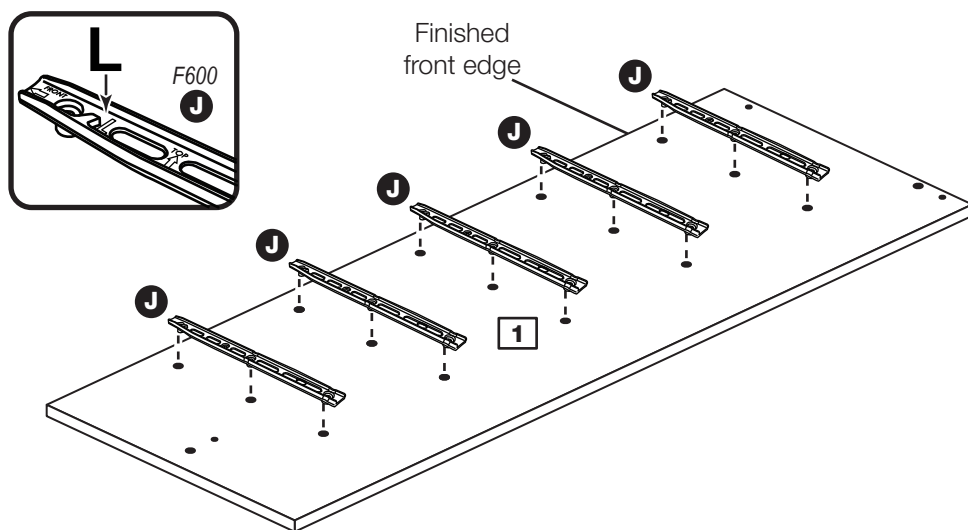

## Step 8

### Prepare the right side

Push fit 5 right runners **J** marked 'R' into the right side **2**.

**Note:** Runners must be be fitted flat against the panel. If necessary gently tap into final position.

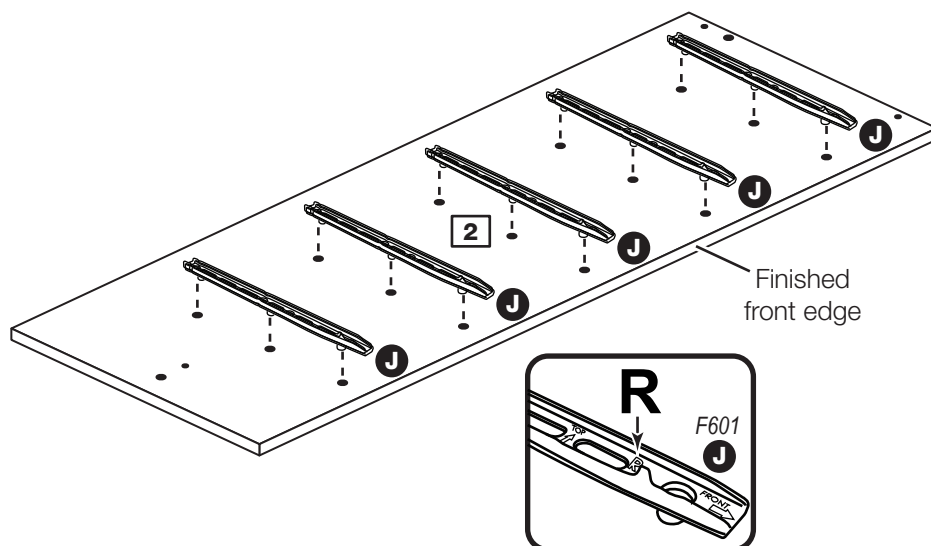

## Step 9

### Prepare the top

Tap 2 wooden dowels **A** into the top **3**.

Fix the bracket **I** in the middle of the top **3**, flush to the back edge using screw **F**.

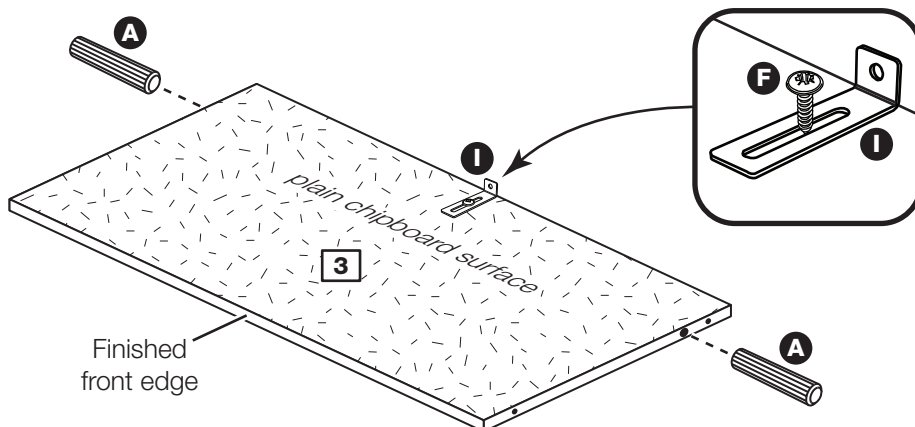

# Assembly Instructions

## Step 10

### Join the top to the right side

Push the top **3** onto the right side **2** and secure with 2 screws **D**.

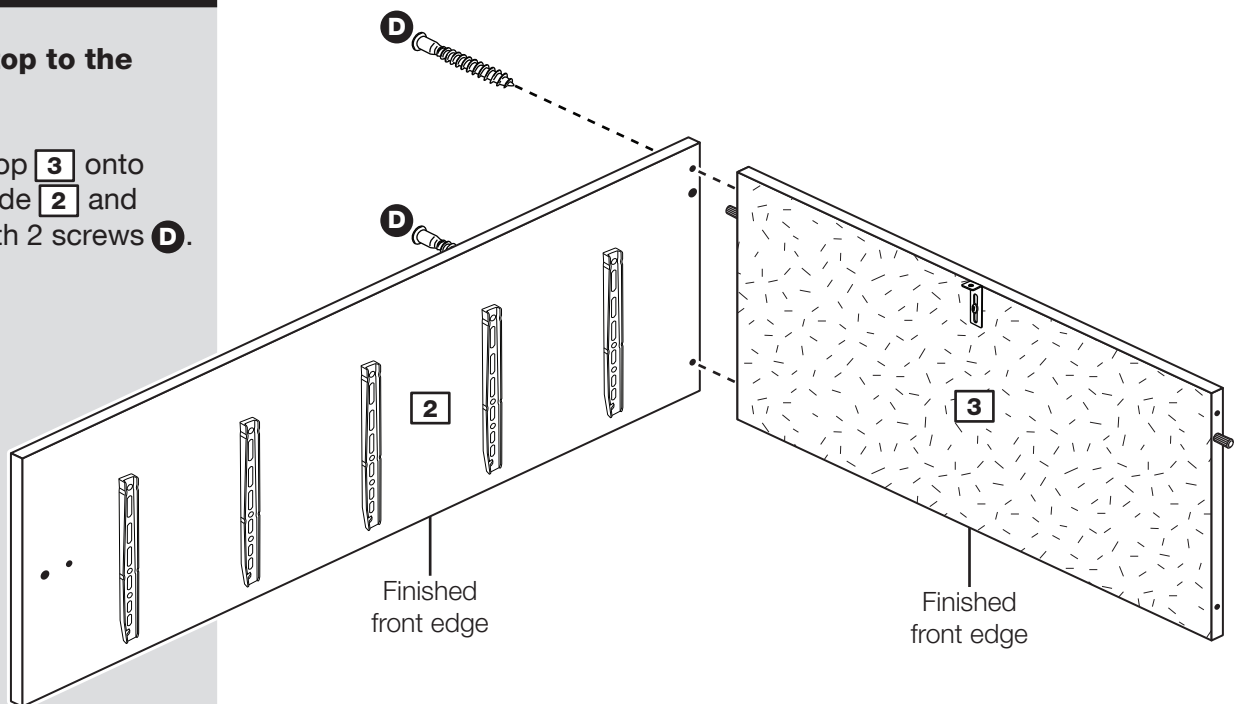

## Step 11

### Prepare the plinth

Tap 2 wooden dowels **A** into the plinth **4**.

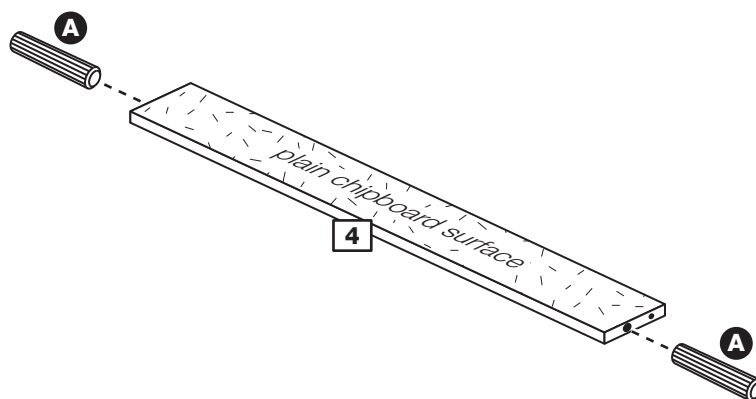

# Assembly Instructions

## Step 12

### Join the plinth to the right side

Push the plinth **4** onto the right side **2** and secure with screw **D**.

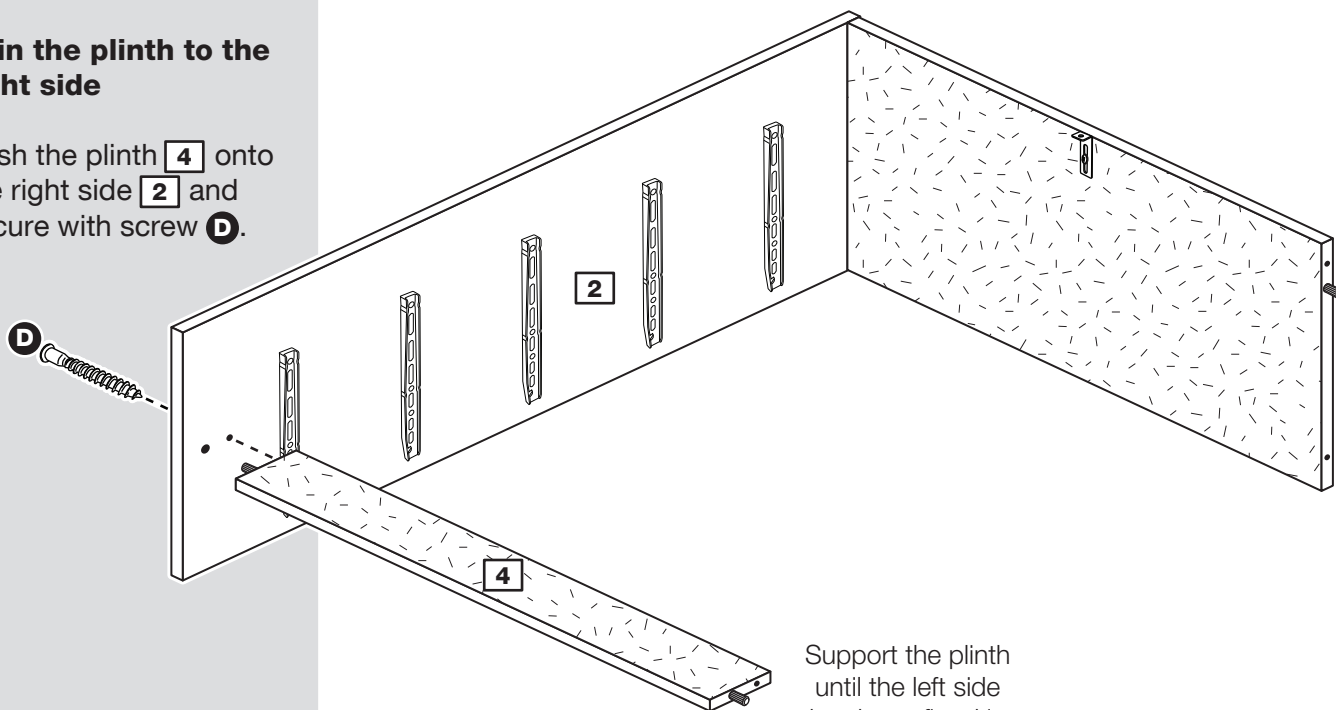

Support the plinth until the left side has been fitted in the next step.

## Step 13

### Fit the left side

Push the left side **1** onto the assembly and secure with 3 screws **D**.

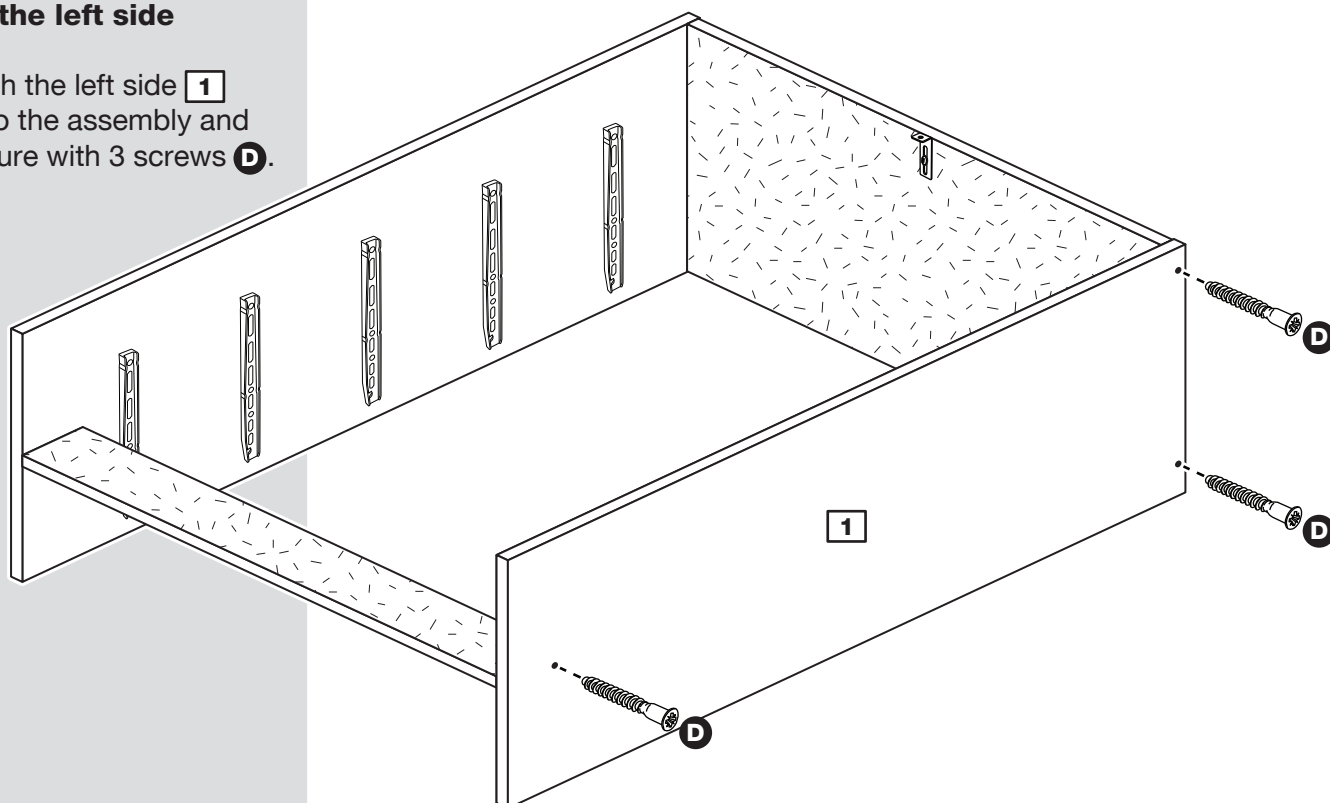



# Assembly Instructions

## Step 15

### Secure unit to a wall

To prevent possible overbalancing we recommend that this unit is secured to a suitable wall by use of the metal bracket **1** fitted to the top **3**.

Fixings are not supplied as they will need to suit the wall type, and the length of screw will depend on the distance of the back of the unit to the wall.



**Warning:** Take care when drilling the wall that you do not drill into any pipes, wires etc. If in doubt, consult an expert.

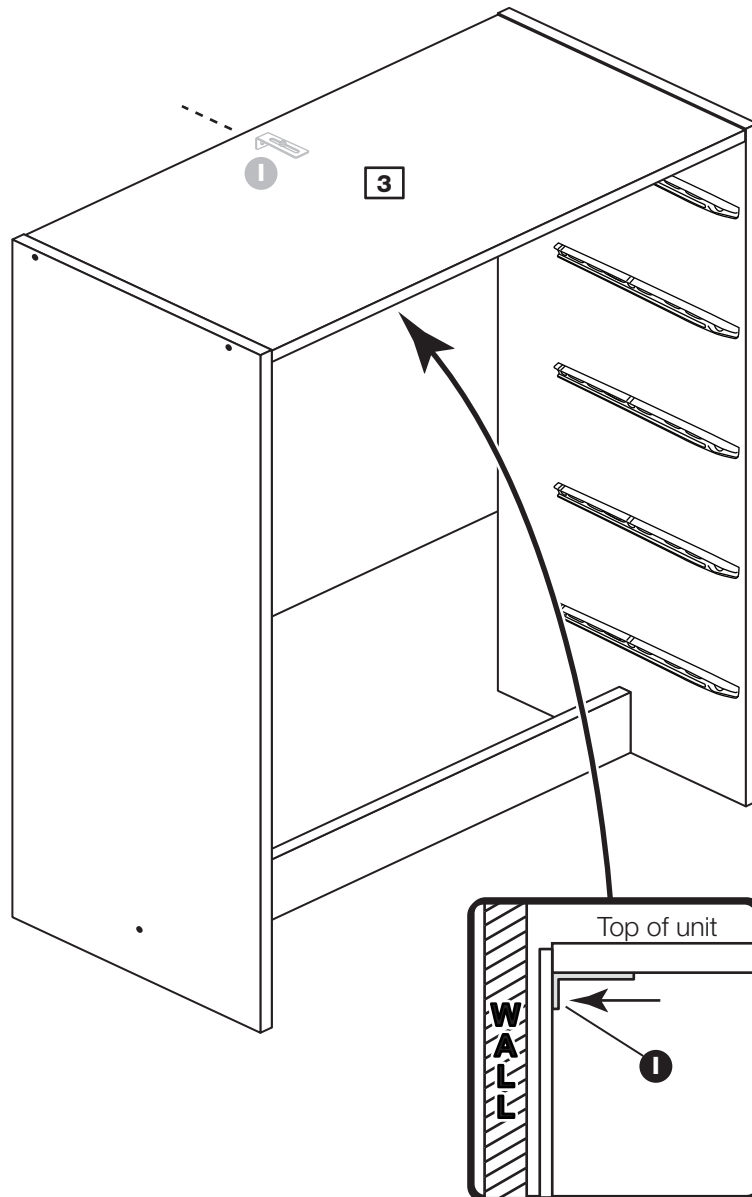

# Assembly Instructions

## Step 16

### Insert the drawers

Lift the front of the drawers whilst inserting to overcome the 'stop' system.

**Note:** To ensure that your drawers run smoothly, spray a small amount of furniture polish into the grooves.

**Assembly is complete**

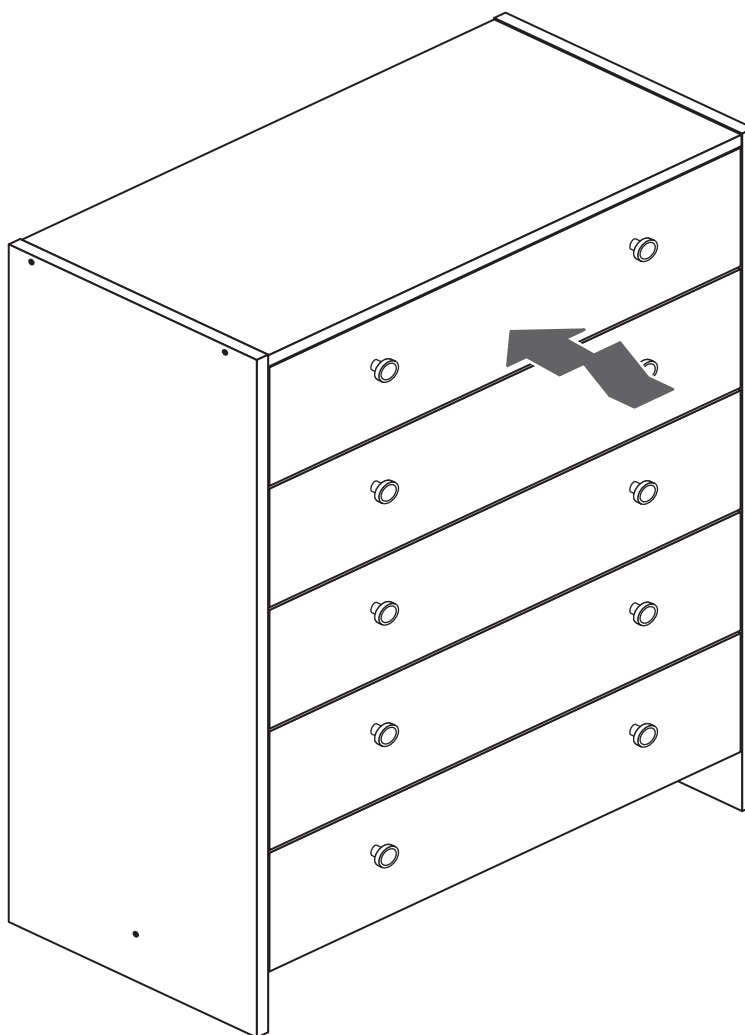

If you need help or have damaged or missing parts, call the **Customer Helpline: 0870 112 1928** or email: **Help@ClickSpares.co.uk** (quoting your original order number and the reference numbers on the component pages)  
Argos Ltd, 489-499 Avebury Boulevard, Central Milton Keynes, MK9 2NW



# Seville - 5 Drawer Chest

Assembly Instructions - Please keep for future reference

184/9198

189/6385

145/0862

184/8319

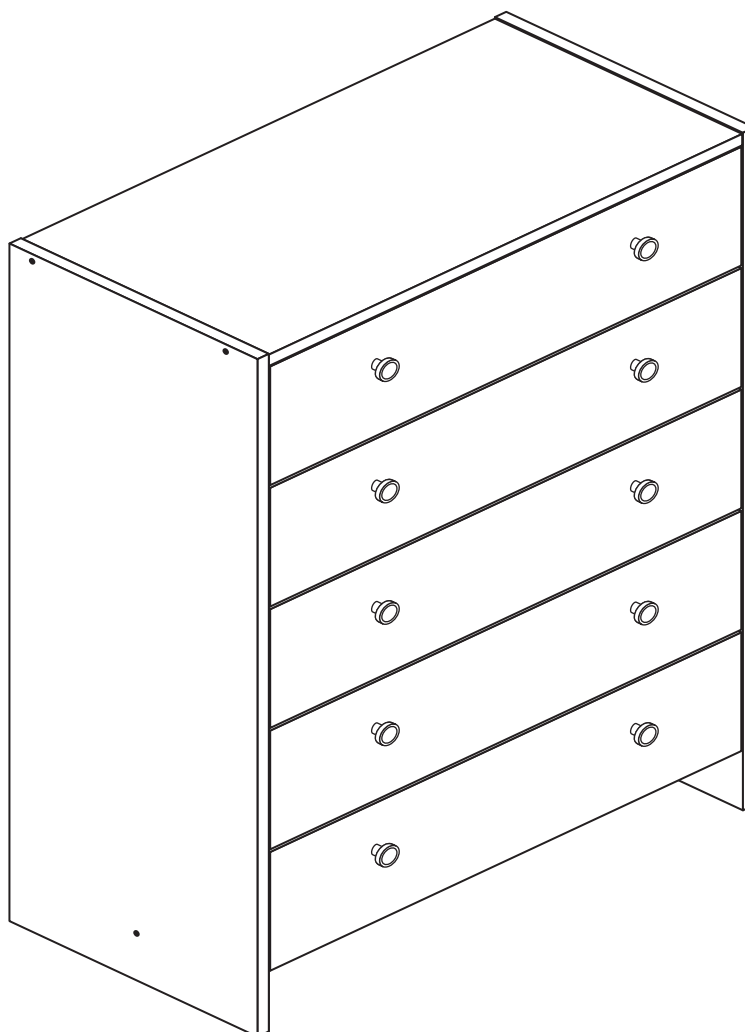

## Dimensions

Width - 66cm

Depth - 33cm

Height - 91cm



**MADE IN  
BRITAIN**

**Important** - Please read these instructions fully before starting assembly

If you need help or have damaged or missing parts, call the **Customer Helpline: 0870 112 1928** or email: [Help@ClickSpares.co.uk](mailto:Help@ClickSpares.co.uk) (quoting your original order number)



# Safety and Care Advice

**Important - Please read these instructions fully before starting assembly**

- **Warning:** This unit weighs approximately 21kgs. Please lift with care.

- Check you have all the components and tools listed on pages 2 and 3.

- Remove all fittings from the plastic bags and separate them into their groups.

- Keep children and animals away from the work area, small parts could choke if swallowed.

- Parts of the assembly will be easier with 2 people.

- Make sure you have enough space to layout the parts before starting.

- Do not stand or put weight on the product, this could cause damage.

- Assemble the item as close to its final position (in the same room) as possible.

- Assemble on a soft level surface to avoid damaging the unit or your floor (use opened out unit carton).



- We do not recommend the use of power drill/drivers **for inserting screws**, as this could damage the unit. Only use hand screwdrivers.

- **Safety note:** It is recommended that this unit is secured to a wall using the overbalance protector kit supplied or, an alternative fixing method of your choice.

- Dispose of all packaging carefully and responsibly.

## Care and maintenance

- Only clean using a damp cloth and mild detergent, do not use bleach or abrasive cleaners.

- From time to time check that there are no loose screws on this unit.

- This product should not be discarded with household waste. Take to your local authority waste disposal centre.

**Note:** If required the next page can be cut out and used as reference throughout the assembly. Keep this page with these instructions for future reference.

# Components - Panels

If you have damaged or missing components, call the **Customer Helpline: 0870 112 1928** or email: **Help@ClickSpares.co.uk** (quoting your original order number and the reference numbers below)

Please check you have all the panels listed below

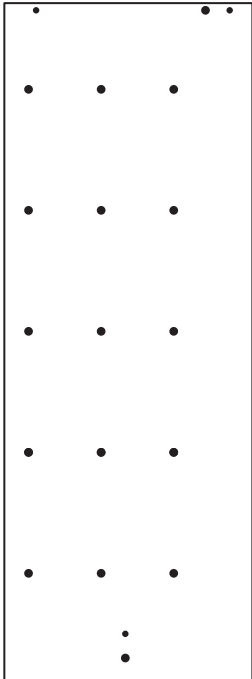

**1** Left Side (D2503A)  
(896 x 328mm)

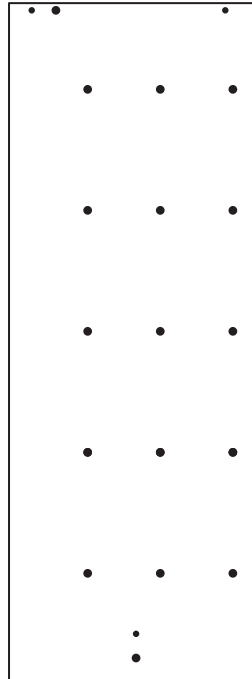

**2** Right Side (D2504A)  
(896 x 328mm)



**3** Top (D2488A)  
(627 x 327mm)

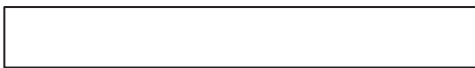

**4** Plinth (D2491A)  
(627 x 80mm)

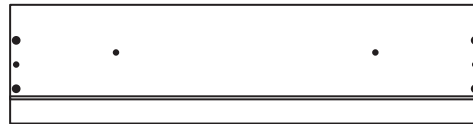

**5** Drawer Front (D2492A)  
(623 x 157mm) x 5

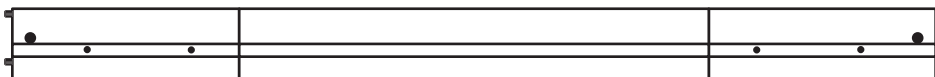

**6** Drawer Wrap (WSAV)  
(1221 x 95mm) x 5



**7** Drawer Base (TSAV)  
(299 x 608mm) x 5

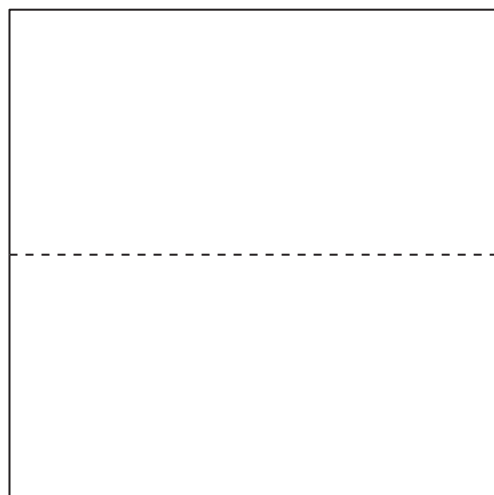

**8** Back (X653-648)  
(653 x 648mm)









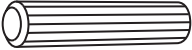
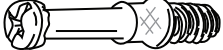

# Components - Fittings

If you have damaged or missing components, call the **Customer Helpline: 0870 112 1928** or **email: Help@ClickSpares.co.uk** (quoting your original order number and the reference numbers below)

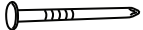
Please check you have all the fittings listed below

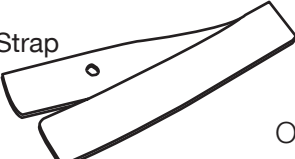
**Note:** The quantities below are the correct amount to complete the assembly. In some cases more fittings may be supplied than are required.

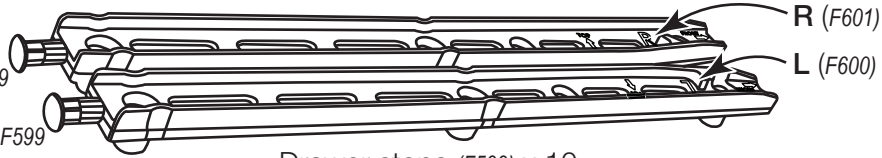
<p><b>A</b> </p> <p>Wooden dowel (F22) x 4</p>	<p><b>B</b> </p> <p>Metal dowel (F901) x 10</p>	<p><b>C</b> </p> <p>Small locking nut (F3) x 10</p>
<p><b>D</b> </p> <p>40mm Screw (F910) x 6</p>	<p><b>E</b> </p> <p>25mm Screw (F95) x 10</p>	<p><b>F</b> </p> <p>Nail (F51) x 15</p>
<p><b>G</b> </p> <p>Handle (F300) x 10</p>	<p><b>H</b>   Screw  Washer x 2</p> <p>Overbalance protector kit (F269) x 1</p>	
<p><b>I</b> </p> <p>Drawer stops (F599) x 10 Runners (F600) x 5 and (F601) x 5</p>		

## Tools required

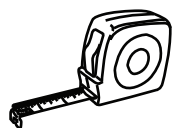

Rule



Cross-head screwdriver



Scissors



Hammer



Eye protection (when using a hammer or drill)



Electric drill (do not use for fitting screws)

## Ruler - Use this ruler to help correctly identify the screws

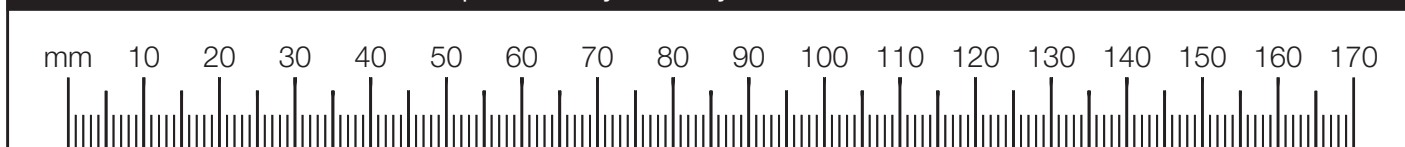

# Assembly Instructions

If you have damaged or missing components, call the Customer Helpline: 0870 112 1928 or email: [Help@ClickSpares.co.uk](mailto:Help@ClickSpares.co.uk) (quoting your original order number and the reference numbers below)

## Step 1

### Prepare the drawer fronts

Screw 2 metal dowels **B** into each of the drawer fronts **5**.

**Note:** Tighten the metal dowels up fully against the panel.

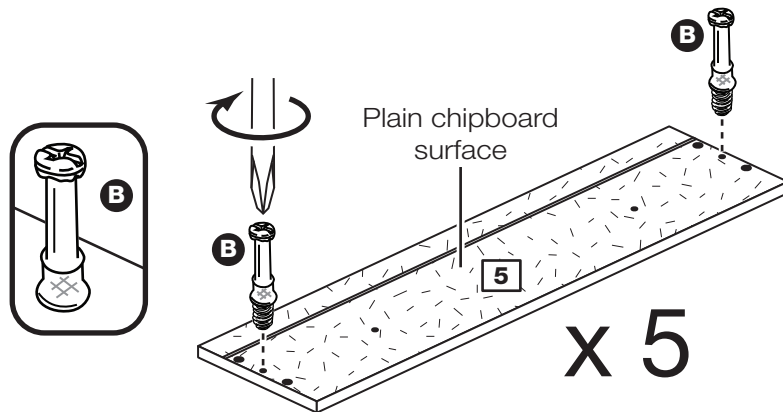

## Step 2

### Prepare the drawer wraps

Insert 2 small locking nuts **C** into each of the drawer wraps **6**.

**Note:** The arrow on the locking nut **must** point towards the hole in the edge of the panel.

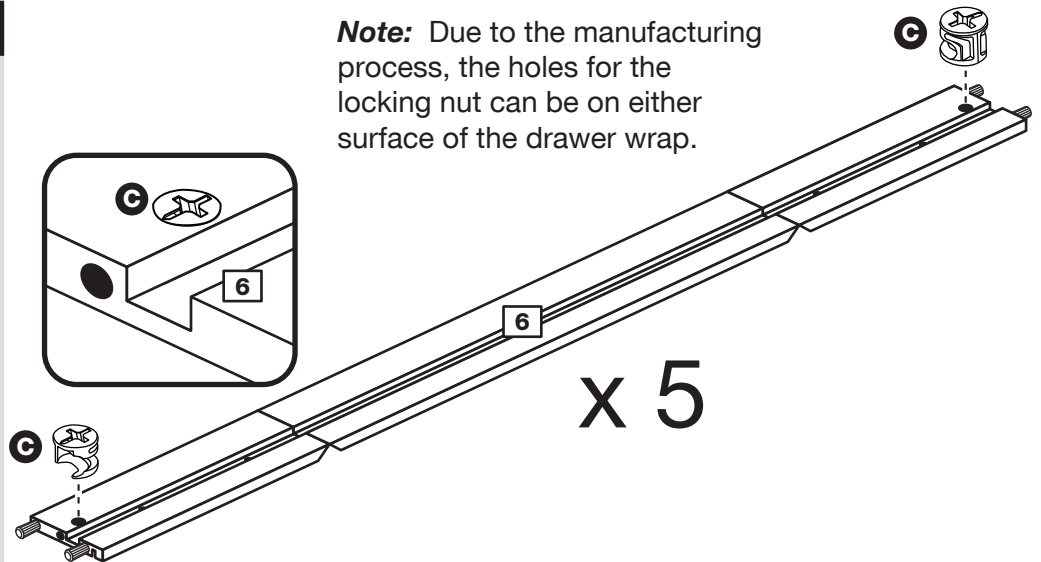

## Step 3

### Fit the drawer base

Place the drawer base **7** into the narrow slot on the drawer wrap **6**. Fold the wrap around the drawer base.

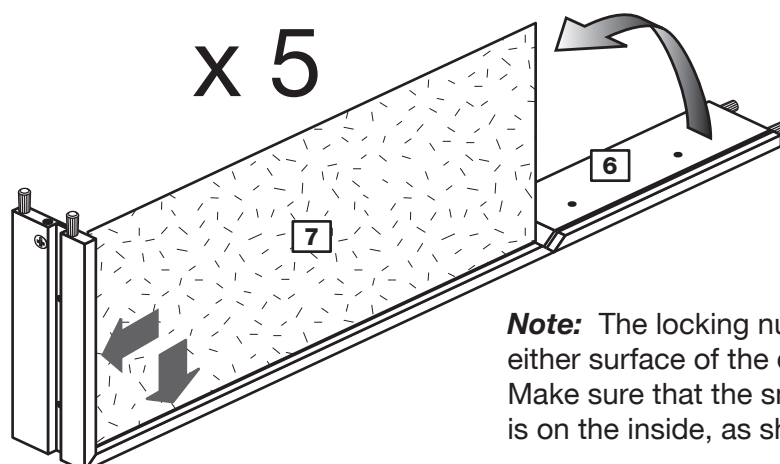

**Note:** The locking nuts can be on either surface of the drawer sides. Make sure that the small groove is on the inside, as shown.

# Assembly Instructions

## Step 4

### Fit the drawer front

Turn drawer wrap **6** assembly over and push it onto the back of the drawer front **5**.

**Note:** Turn the locking nuts **C** clockwise to secure the panels - more than 1/2 a turn.

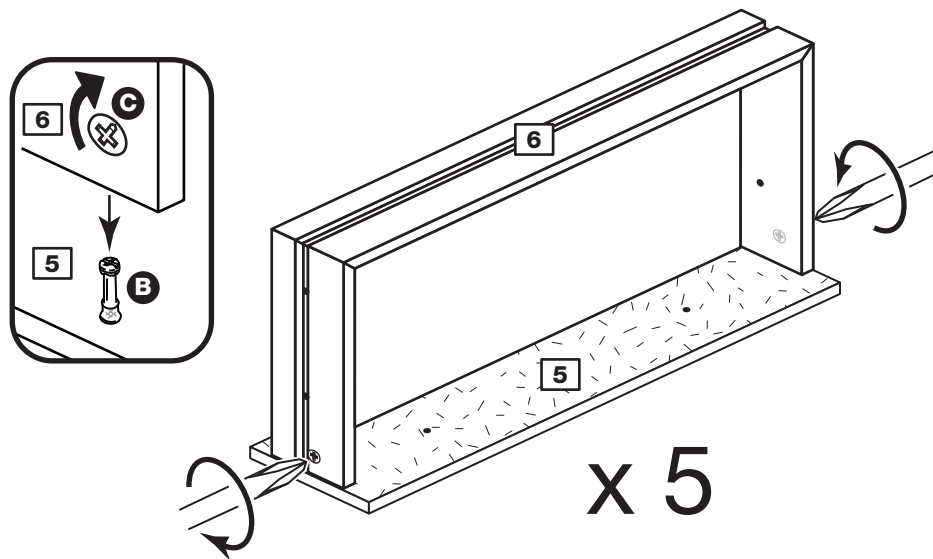

## Step 5

### Attach the drawer stops

Carefully break off 2 drawer stops (F599) from a set of drawer runners **1**.

Push the drawer stops fully through the drawer wrap **6** from the inside.

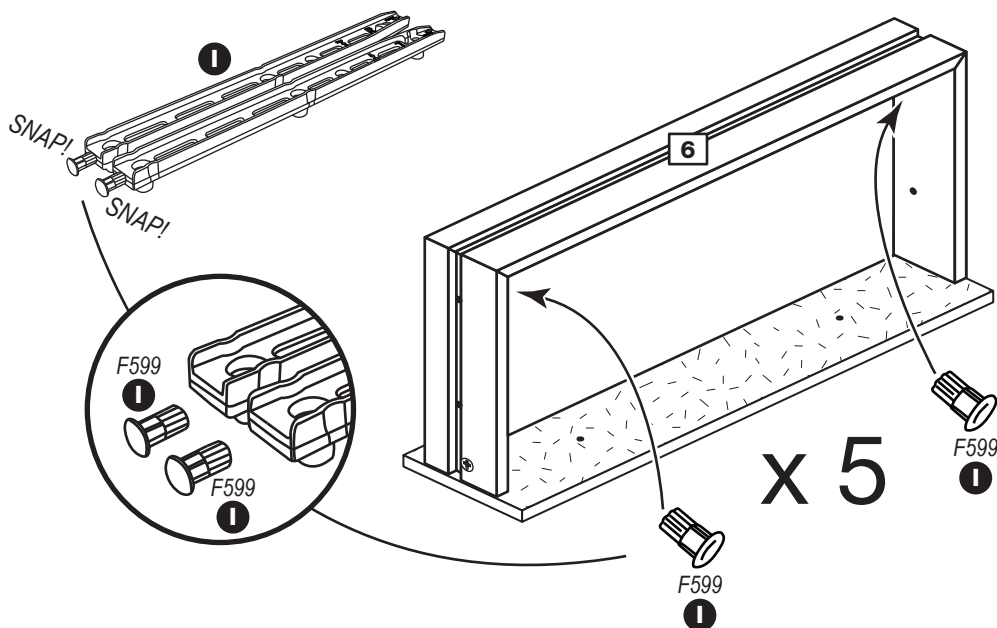

## Step 6

### Attach the handles

Attach 2 handles **G** to each of the 5 drawer fronts **5** using 2 screws **E**.

**Note:** Do not overtighten the screws.

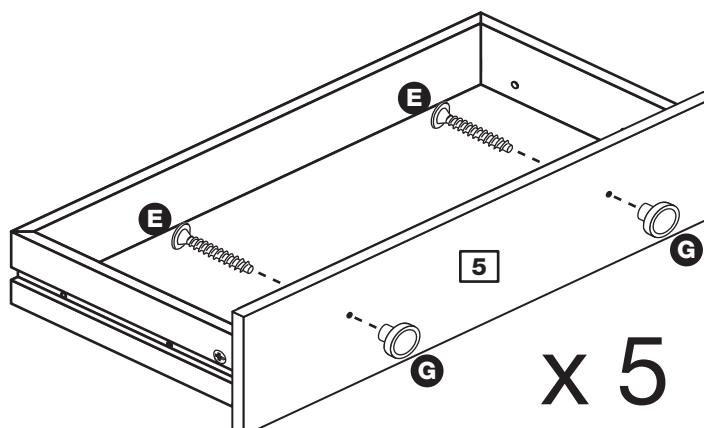

# Assembly Instructions

## Step 7

### Prepare the left side

Separate the runners ①.

Push fit 5 left runners ① marked 'L' into the left side ①.

**Note:** Runners must be fitted flat against the panel. If necessary gently tap into final position.

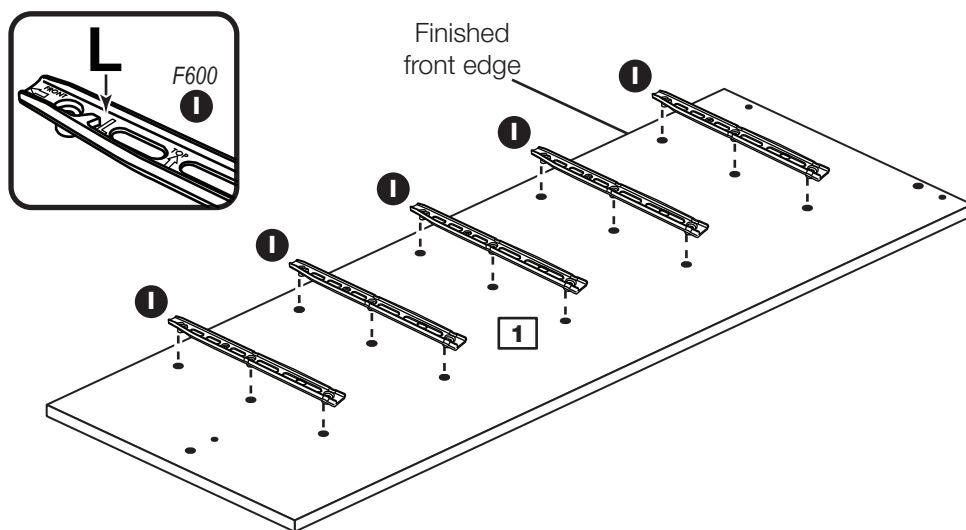

## Step 8

### Prepare the right side

Push fit 5 right runners ① marked 'R' into the right side ②.

**Note:** Runners must be fitted flat against the panel. If necessary gently tap into final position.

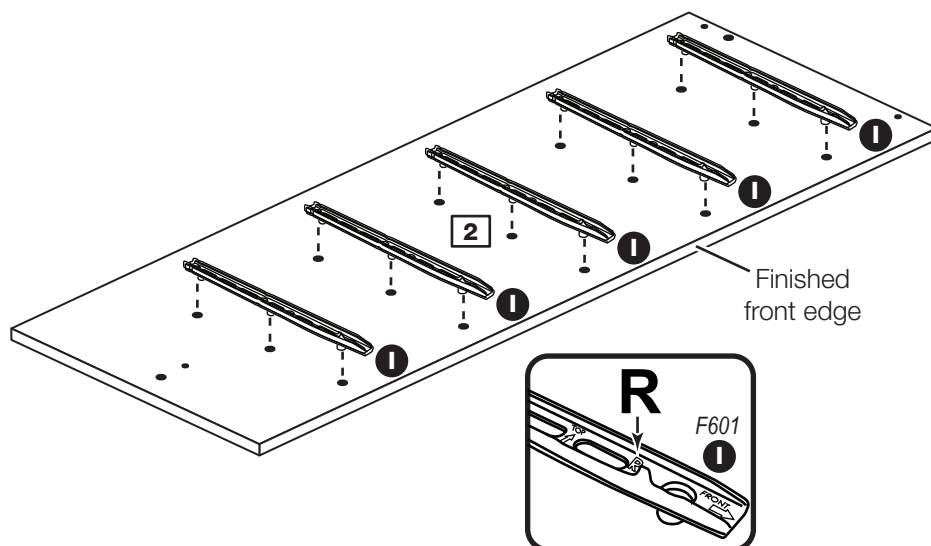

## Step 9

### Prepare the top

Tap 2 wooden dowels ① into the top ③.

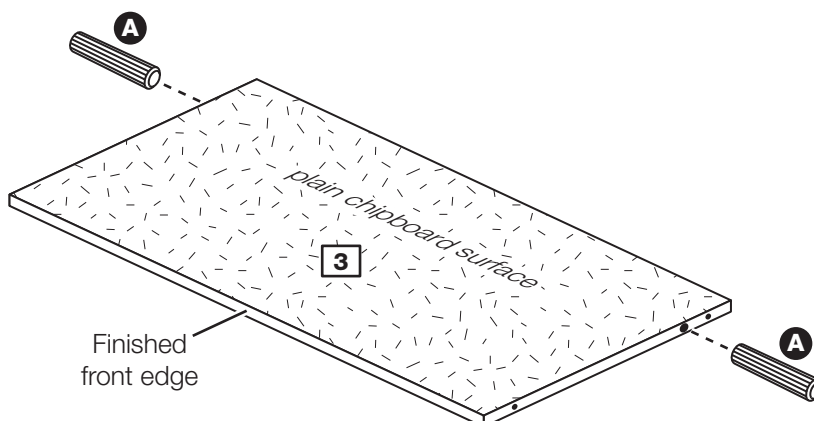

# Assembly Instructions

## Step 10

### Join the top to the right side

Push the top **3** onto the right side **2** and secure with 2 screws **D**.

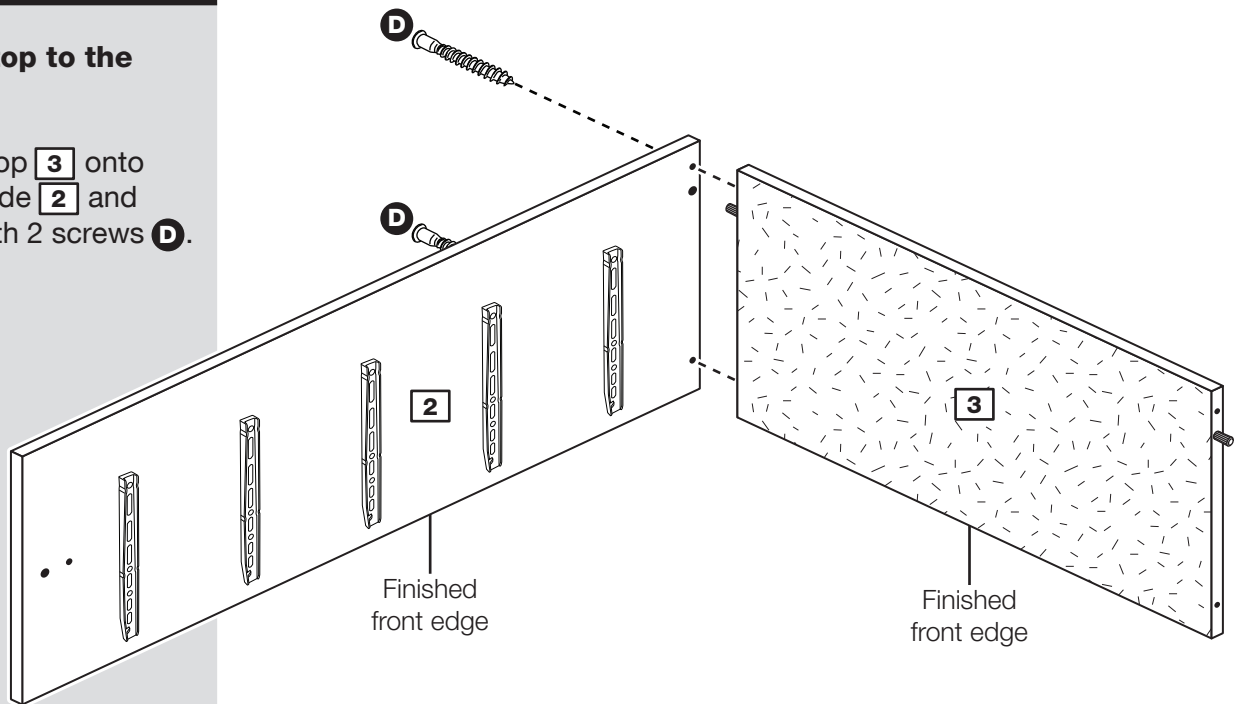

## Step 11

### Prepare the plinth

Tap 2 wooden dowels **A** into the plinth **4**.

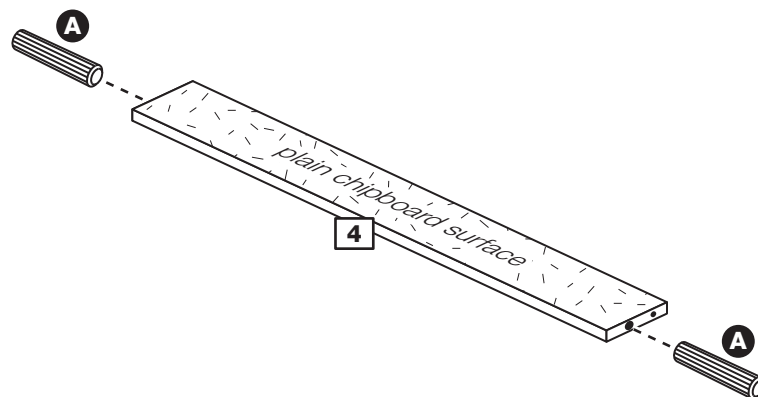



# Assembly Instructions

## Step 12

### Join the plinth to the right side

Push the plinth **4** onto the right side **2** and secure with screw **D**.

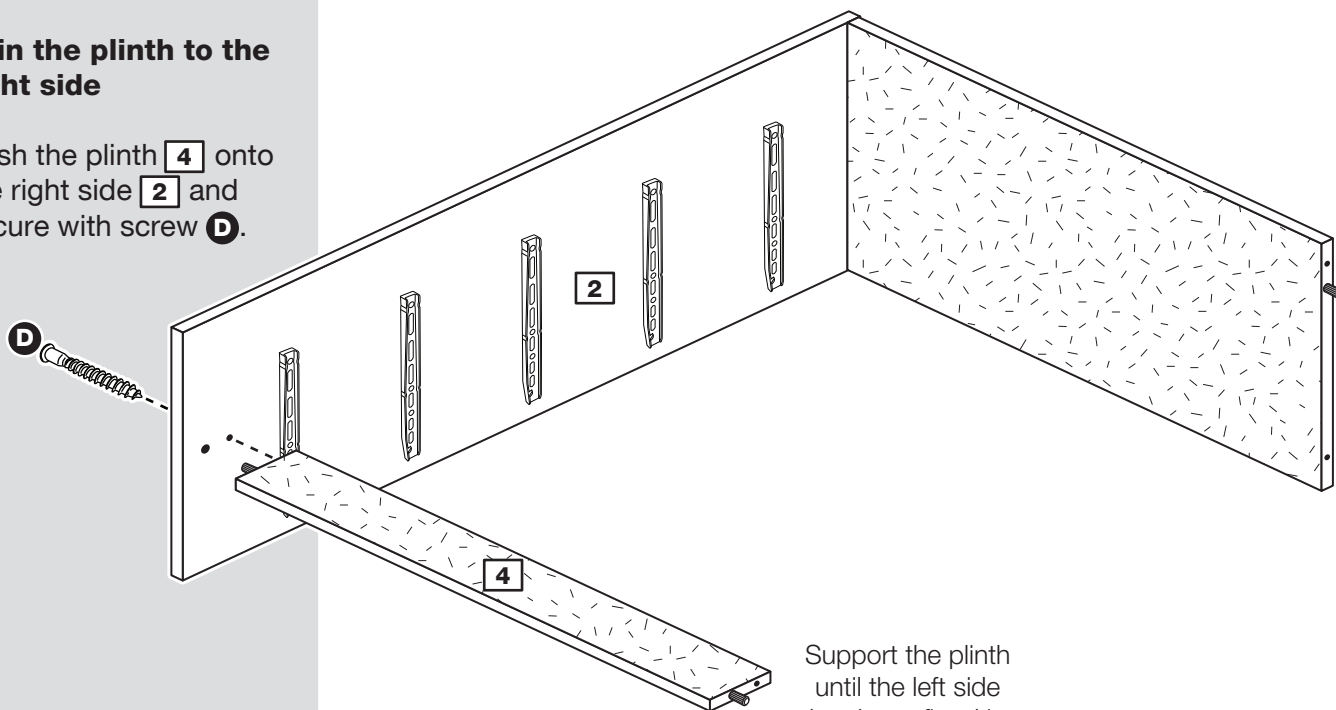

Support the plinth until the left side has been fitted in the next step.

## Step 13

### Fit the left side

Push the left side **1** onto the assembly and secure with 3 screws **D**.

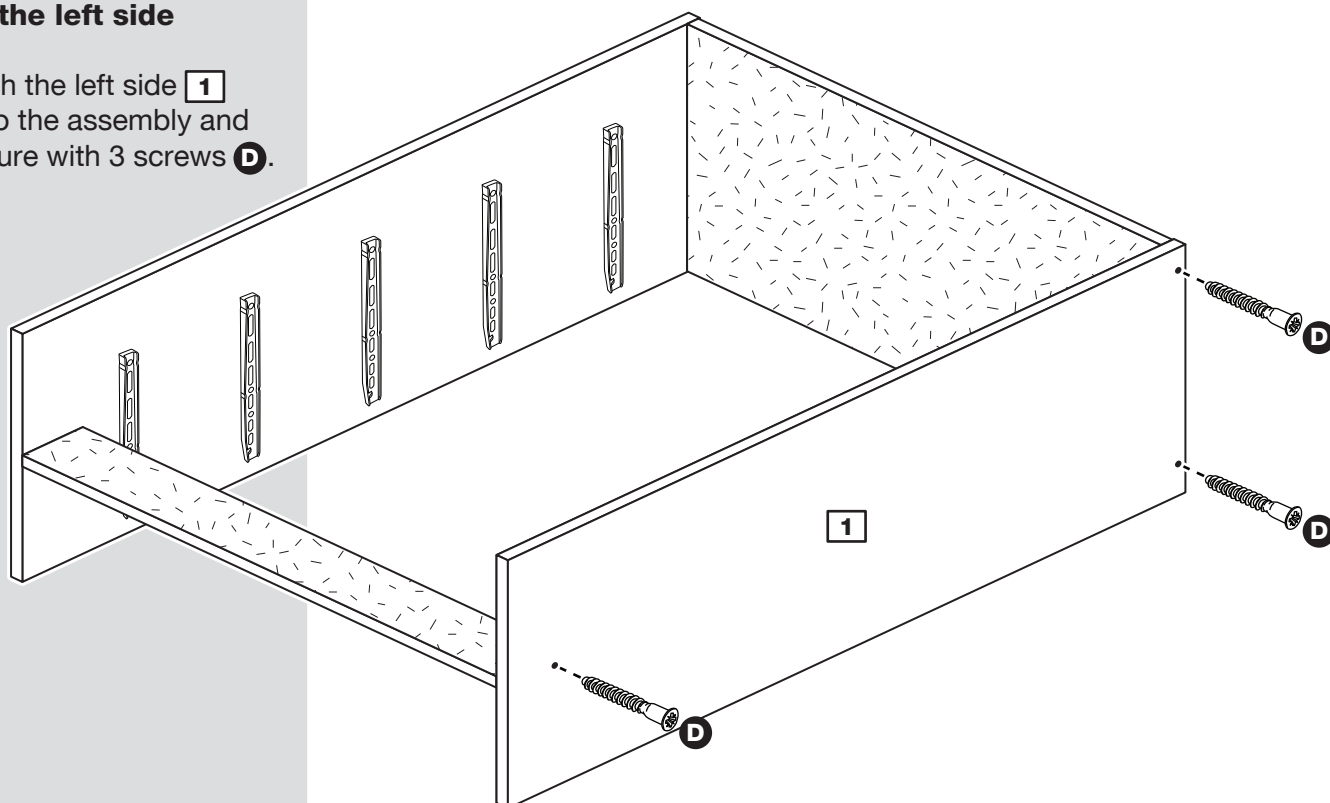



# Assembly Instructions

## Step 15

### Insert the drawers

Lift the front of the drawers whilst inserting to overcome the 'stop' system.

**Note:** To ensure that your drawers run smoothly, spray a small amount of furniture polish into the grooves.

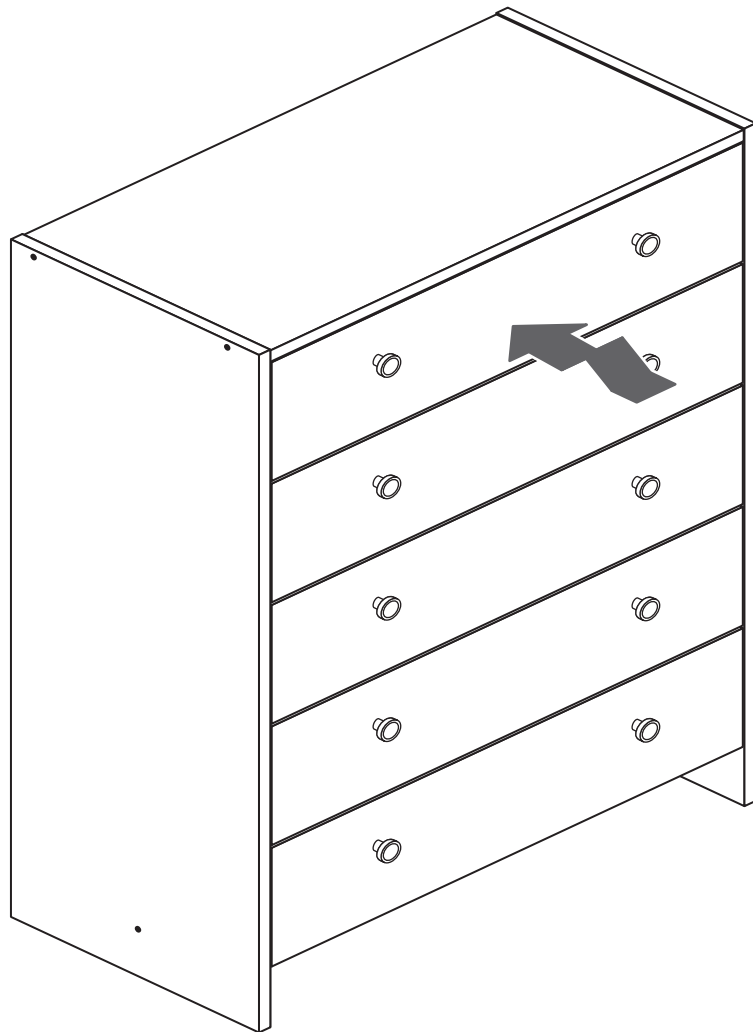

# Assembly Instructions

## Step 16

### Fit the overbalance protector kit

To prevent possible overbalancing we recommend that this unit is secured to a suitable wall by fitting of the overbalance protector kit **H** to the unit, or an alternative fixing method of your choice.

Wall fixings are not supplied as they will need to suit the wall type.

**Note:** Take care when drilling the wall that you do not drill into any pipes, wires etc. If in doubt, consult an expert.

### Example

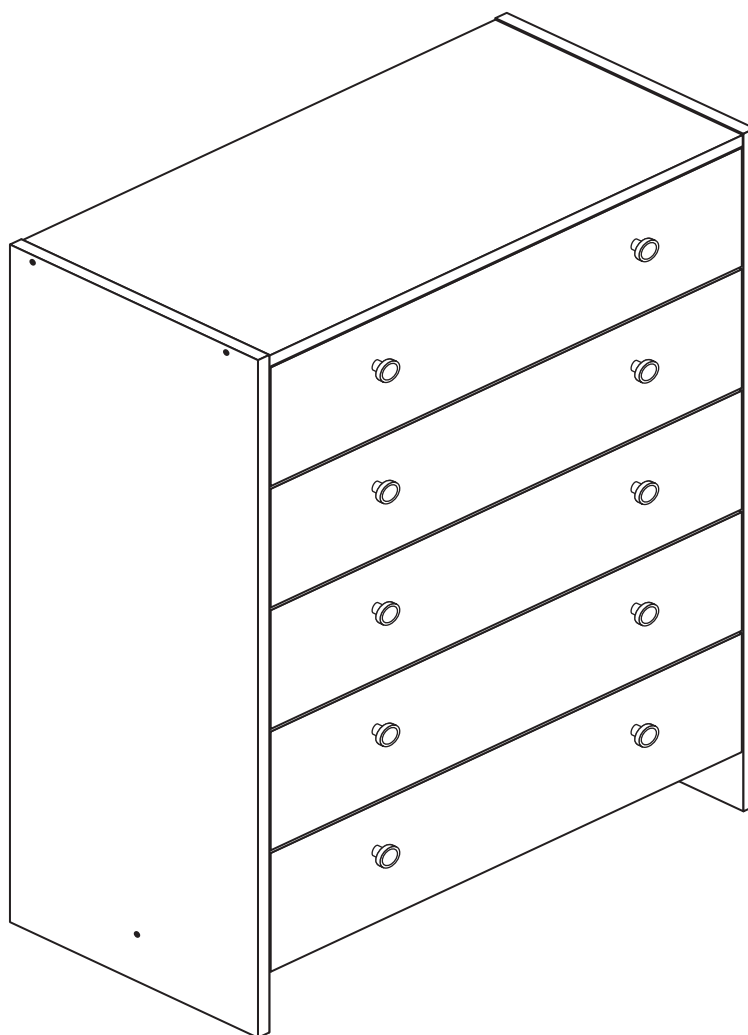
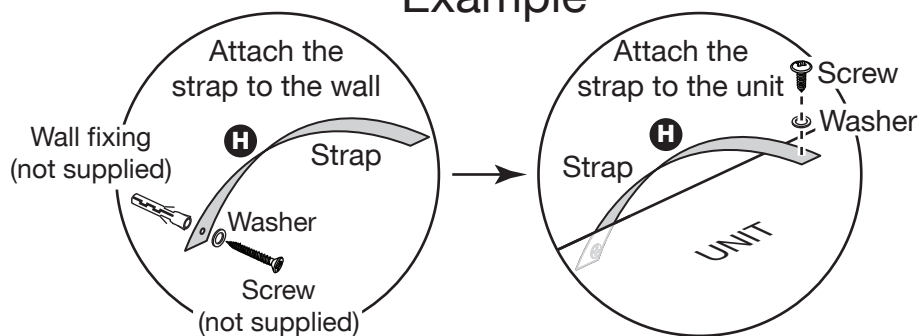

If you need help or have damaged or missing parts, call the **Customer Helpline: 0870 112 1928** or email: [Help@ClickSpares.co.uk](mailto:Help@ClickSpares.co.uk) (quoting your original order number and the reference numbers on the component pages)  
Argos Ltd, 489-499 Avebury Boulevard, Central Milton Keynes, MK9 2NW