

Akari - Pair of Chairs

Assembly Instructions - Please keep for future reference

143/9357

144/8520

SCHREIBER

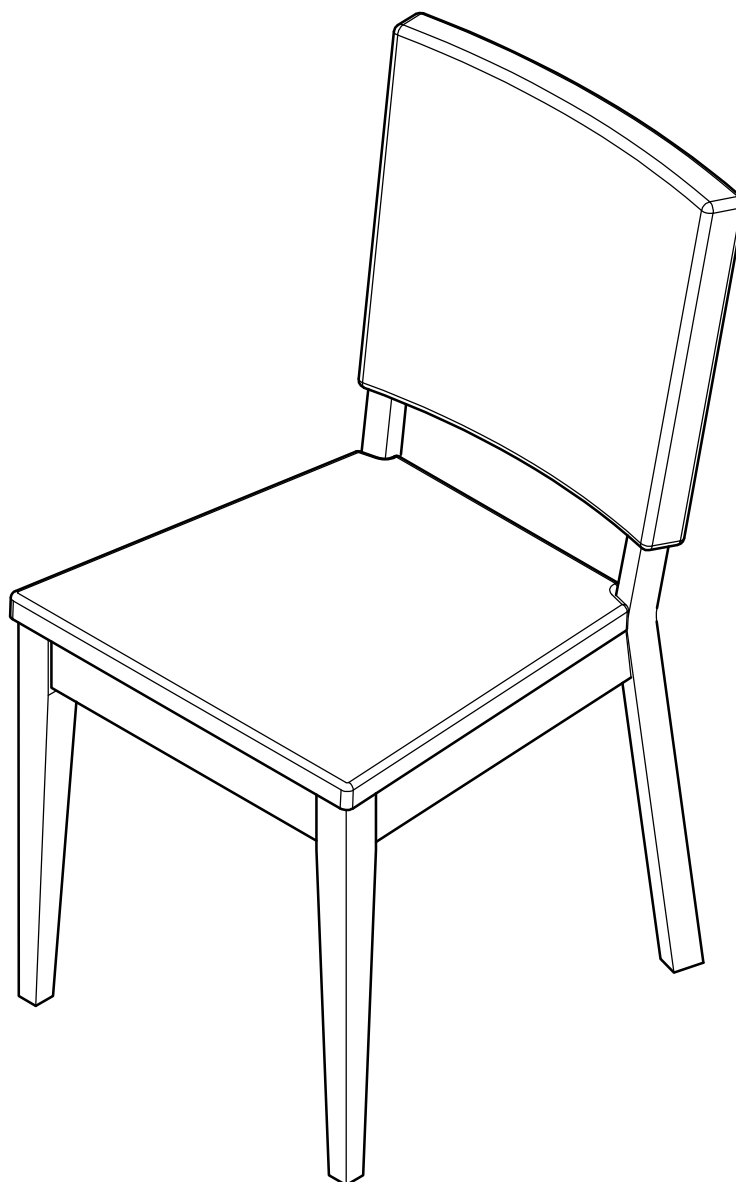

Dimensions

Width - 45.2cm

Depth - 55.75cm

Height - 88cm

Important - Please read these instructions fully before starting assembly.

If you need help or have damaged or missing parts, call the **Customer Helpline: 08456 400800**



Safety and Care Advice

Important - Please read these instructions fully before starting assembly.

- Check you have all the components and tools listed on page 2.
- Remove all fittings from the plastic bags and separate them into their groups.
- Keep children and animals away from the work area, small parts could choke if swallowed.
- Make sure you have enough space to layout the parts before starting.
- Do not stand or put weight on the product, this could cause damage.
- Assemble the item as close to its final position (in the same room) as possible.
- Assemble on a soft flat / firm surface to avoid damaging the unit or your floor.
- Parts of the assembly will be easier with 2 people.
-  We do not recommend the use of power drill/ drivers **for inserting screws**, as this could damage the unit. Only use hand screwdrivers.
- Dispose of all packaging carefully and responsibly.
- Maximum user weight: 110kg.

Care and maintenance

- Only clean using a damp cloth and mild detergent, do not use bleach or abrasive cleaners.
- From time to time check that there are no loose screws on this unit.
- This product should not be discarded with household waste. Take to your local authority waste disposal centre.

Components - Panels

If you have damaged or missing components, call the **Customer Helpline: 08456 400800**

Please check you have all the panels listed below

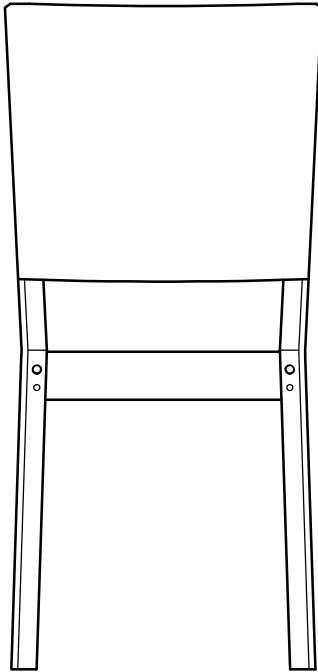

1 Back leg frame x 2
(45 x 88cm)

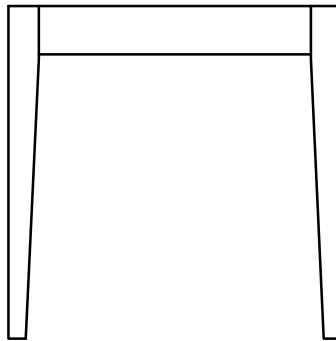

2 Front leg frame x 2
(44 x 44cm)

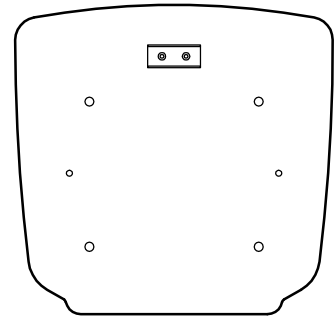

3 Seat pad x 2
(45.2 x 44.2cm)



4 Left apron x 2
(40.1 x 6.4cm)







5 Right apron x 2
(40.1 x 6.4cm)

Components - Fittings

Please check you have all the fittings listed below

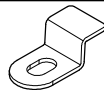
Note: The quantities below are the correct amount to complete the assembly. In some cases more fittings may be supplied than are required.

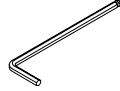
<p>A </p> <p>48.5mm Steel dowel x 8</p>	<p>B </p> <p>Grub screw x 8</p>	<p>C </p> <p>Seat bracket x 4</p>
<p>D </p> <p>15mm Hex head bolt x 4</p>	<p>E </p> <p>M4 Allen key x 1</p>	<p>F </p> <p>M5 Allen key x 1</p>

Ruler - Use this ruler to help correctly identify the screws

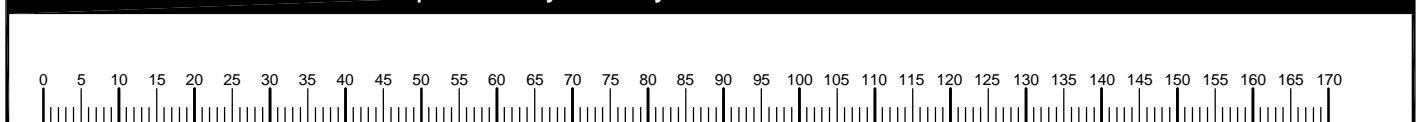

Assembly Instructions

Step 1

Fitting dowels

a: Screw 2 steel dowels **A** into the inset fittings that are located on back leg frame **1** as shown.

Note: Ensure the direction of the holes on fittings are facing correctly as per diagram. **Do not over tighten.**

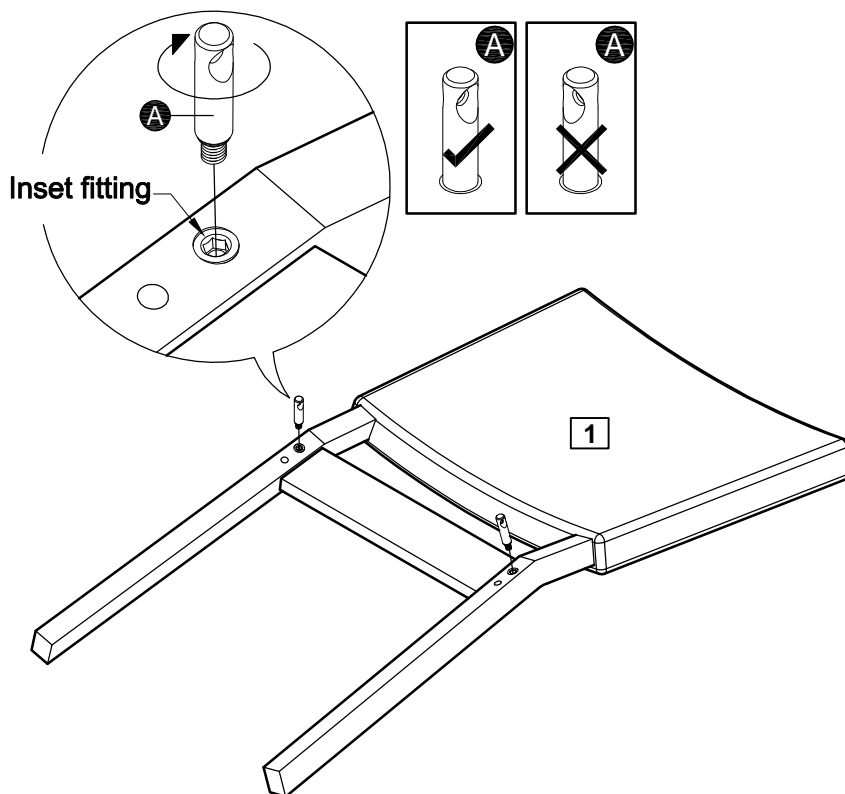

Step 2

Fitting dowels

a: Screw 2 steel dowels **A** into the inset fittings that are located on front leg frame **2** as shown.

Note: Ensure the direction of the holes on fittings are facing correctly as per diagram. **Do not over tighten.**

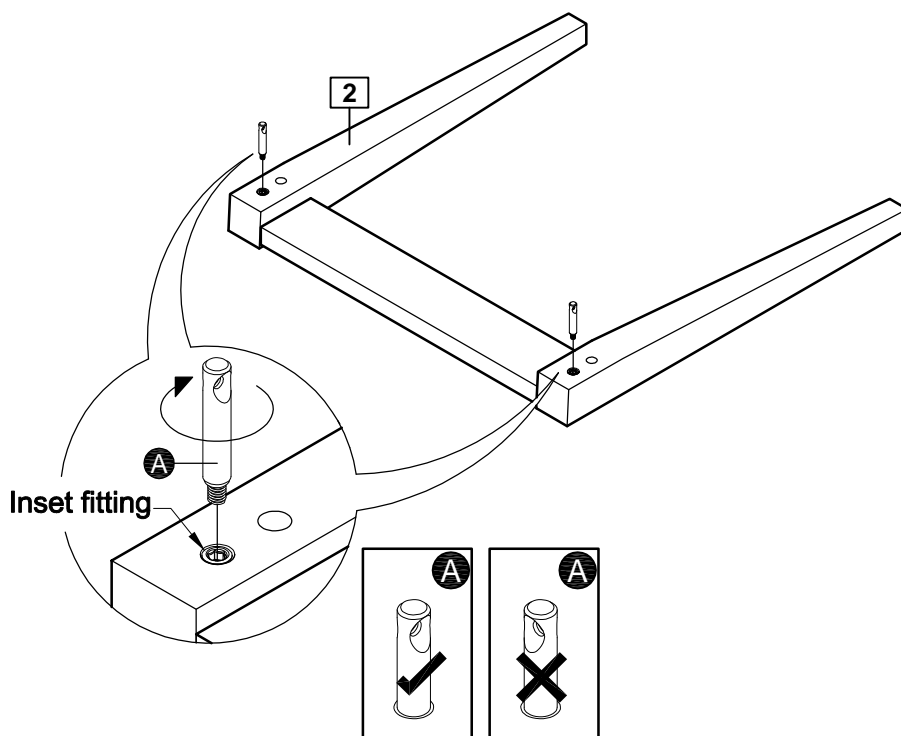

Assembly Instructions

Step 3

Attaching aprons

Position aprons **4** and **5** onto back leg frame **1** as shown.

Note: Ensure steel dowels and wooden dowels are aligned correctly with mating holes to avoid damage.

Ensure end of aprons are flush with back leg frame **1**.

Insert 2 grub screws **B** into aprons **4** and **5** as shown.

Use allen key **F** to turn grub screws **B** clockwise to fix.

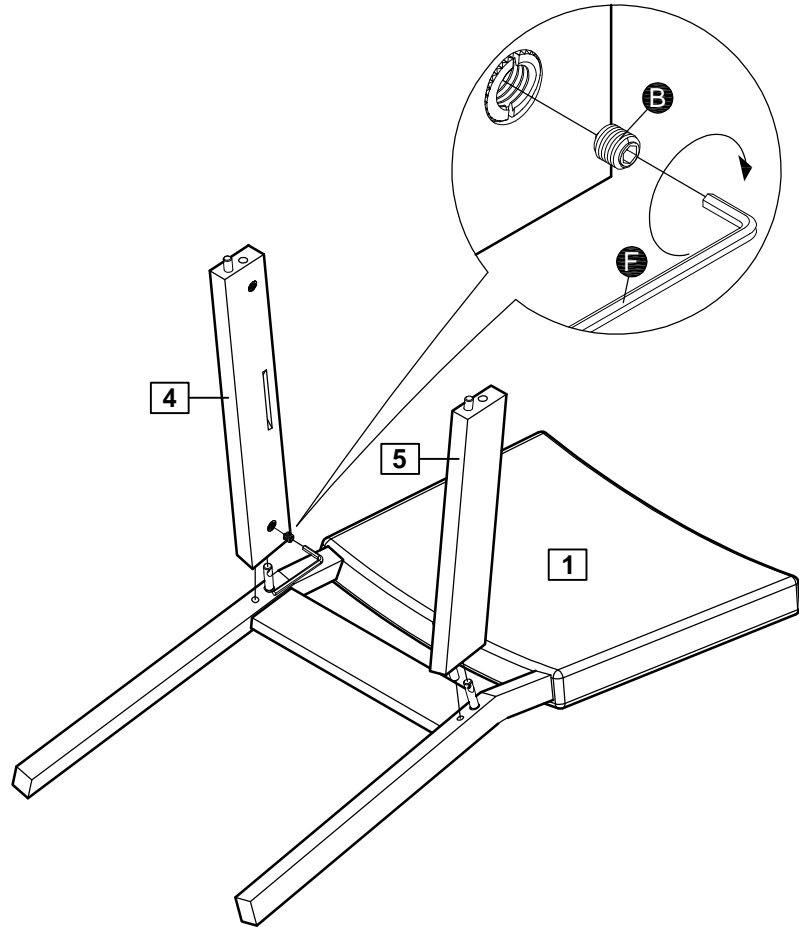

Step 4

Attaching front leg frame

Position front leg frame **2** onto aprons **4** and **5** as shown.

Note: Ensure steel dowels and wooden dowels are aligned correctly with mating holes to avoid damage.

Ensure end of aprons are flush with front leg frame **2**.

Insert 2 grub screws **B** into aprons **4** and **5** as shown.

Use allen key **F** to turn grub screws **B** clockwise to fix.

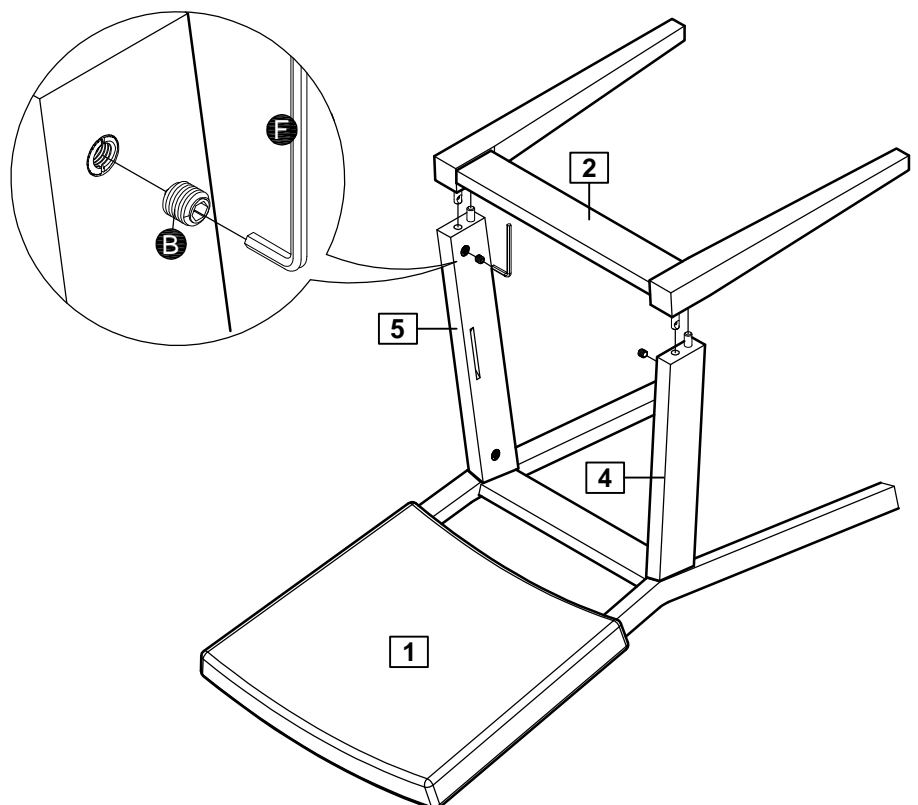

Assembly Instructions

Step 5

Placing seat pad.

a: Place seat pad **3** on a flat, stable, clean and soft surface as shown.

b: Lower the constructed chair frame onto seat pad **3** as shown.

Note: Ensure wooden locator block is inside front leg frame **2** as shown.

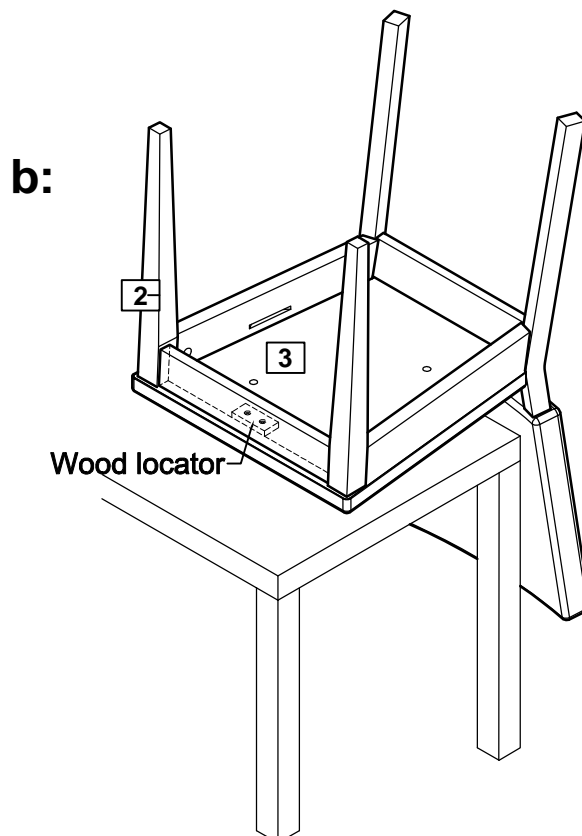
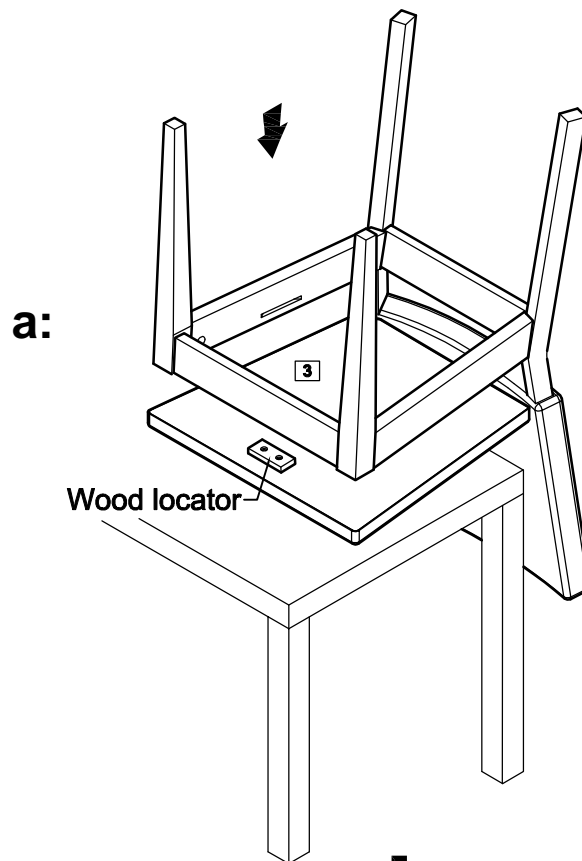

Assembly Instructions

Step 6

Fixing seat pad.

a: Insert 2 seat brackets **C** into the slots on aprons **4** and **5** as shown.

Note: Align holes on seat brackets **C** with holes on seat pad **3**.

b: Insert 2 bolts **D** into the holes of seat brackets **C** and the holes of mating seat pad **3** as shown.

Use allen key **E** to turn bolts **D** clockwise to fix.

Repeat complete process for second chair.

Assembly is complete.

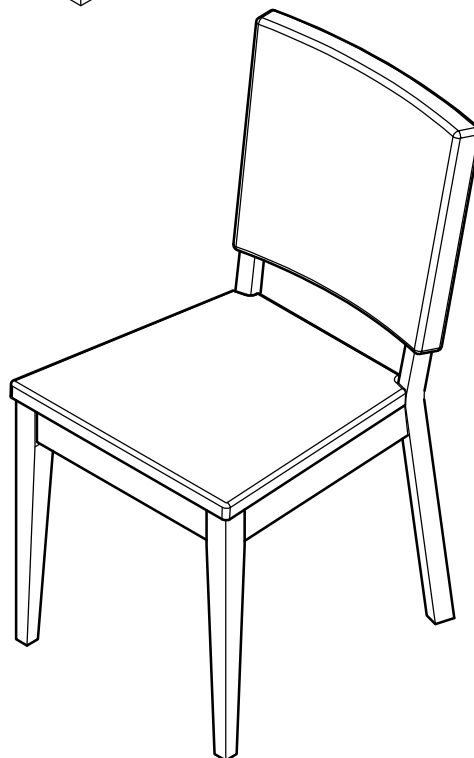
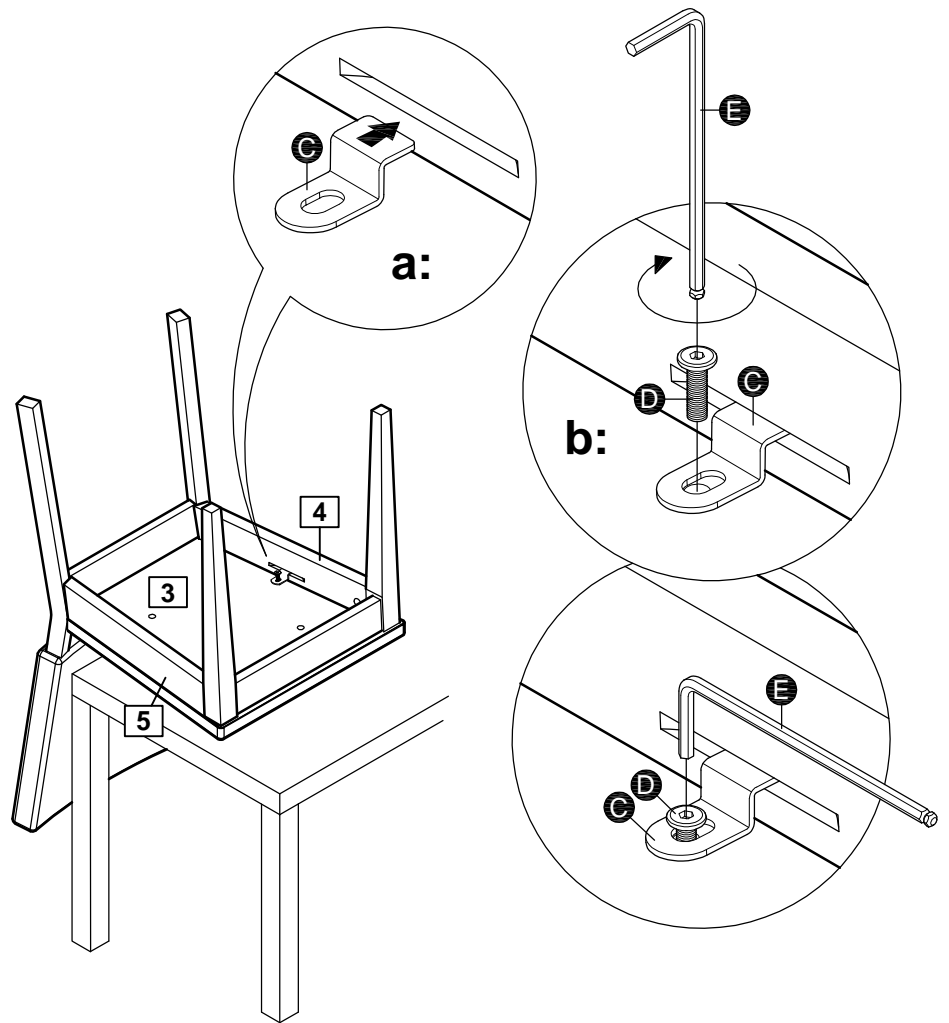

If you need help or have damaged or missing parts, call the **Customer Helpline: 08456 400800**