

Dalton - Pedestal Desk

Assembly Instructions - Please keep for future reference

617/3601

158/5122

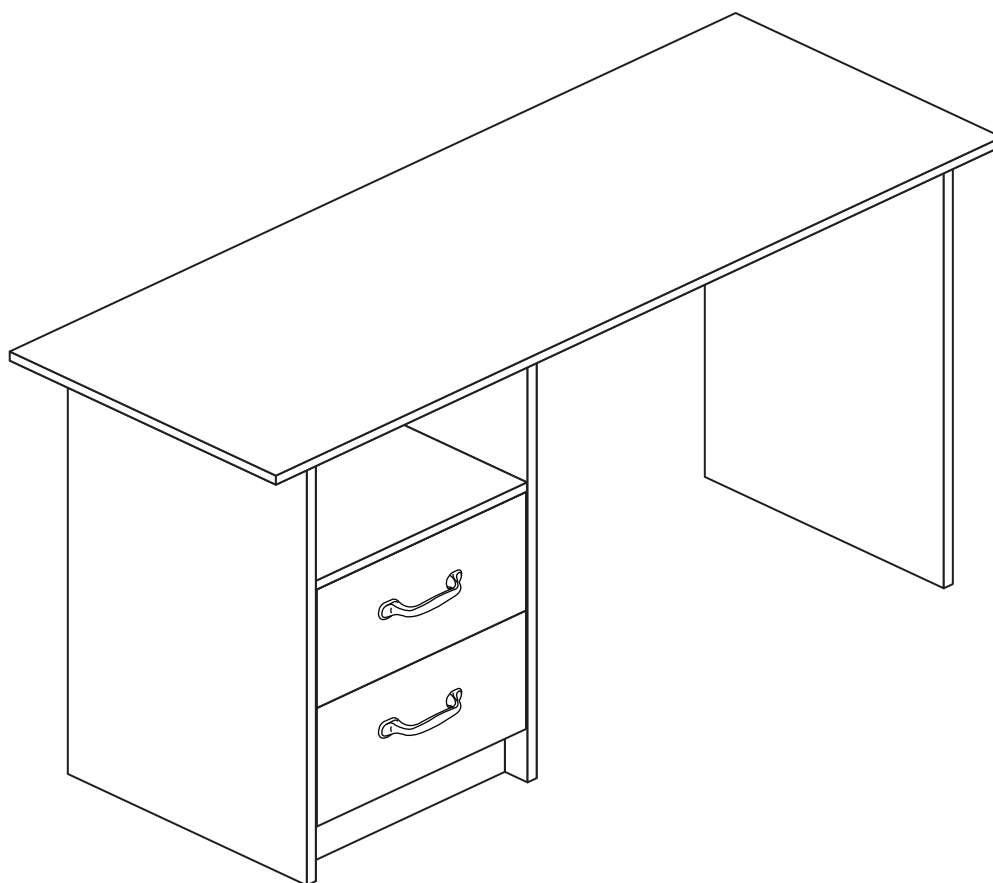

Dimensions

Width - 120cm

Depth - 44cm

Height - 71.5cm



**MADE IN
BRITAIN**

Important - Please read these instructions fully before starting assembly

If you need help or have damaged or missing parts, call the **Customer Helpline: 08456 400800**



Safety and Care Advice

Important - Please read these instructions fully before starting assembly

- **Warning:** This unit weighs approximately 23kgs. Please lift with care.

- Check you have all the components and tools listed on pages 2 and 3.

- Remove all fittings from the plastic bags and separate them into their groups.

- Keep children and animals away from the work area, small parts could choke if swallowed.

- Parts of the assembly will be easier with 2 people.

- Make sure you have enough space to layout the parts before starting.

- Do not stand or put weight on the product, this could cause damage.

- Assemble the item as close to its final position (in the same room) as possible.

- Assemble on a soft level surface to avoid damaging the unit or your floor (use opened out unit carton).



- We do not recommend the use of power drill/drivers **for inserting screws**, as this could damage the unit. Only use hand screwdrivers.

- **Safety note:** It is recommended that this unit is secured to a wall using the bracket supplied.

- Dispose of all packaging carefully and responsibly.

Care and maintenance

- Only clean using a damp cloth and mild detergent, do not use bleach or abrasive cleaners.

- From time to time check that there are no loose screws on this unit.

- This product should not be discarded with household waste. Take to your local authority waste disposal centre.

Note: If required the next page can be cut out and used as reference throughout the assembly. Keep this page with these instructions for future reference.

Components - Panels

If you have damaged or missing components, call the **Customer Helpline: 08456 400800** quoting the reference numbers below

Please check you have all the panels listed below

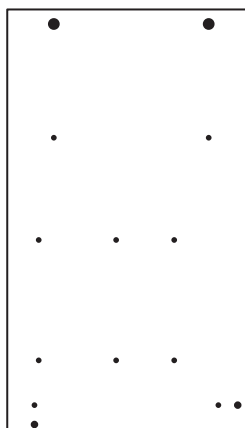

1 Left End (D1822A)
(700 x 395mm)

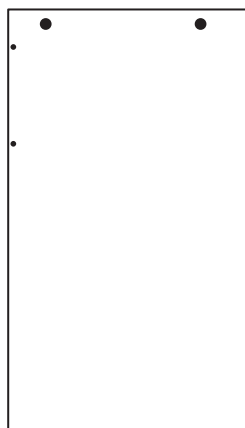

2 Right End (D1823A)
(700 x 395mm)

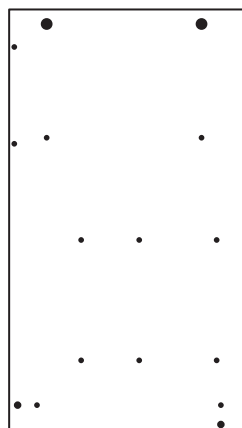

3 Upright (D1824A)
(700 x 395mm)

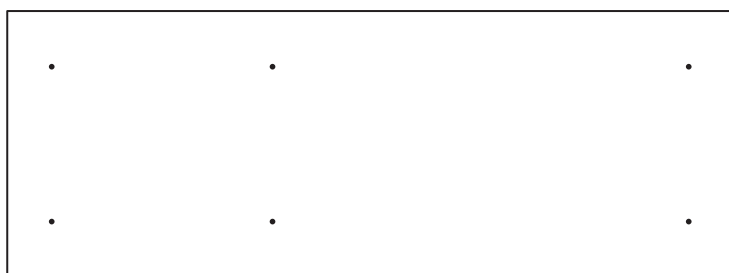

4 Top (D1821A)
(1200 x 440mm)

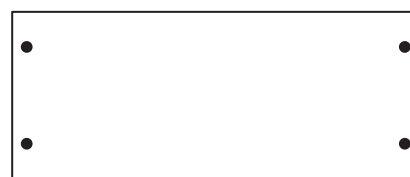

5 Modesty (D1825A)
(673 x 280mm)

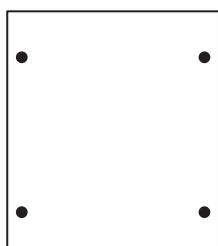

6 Shelf (D1826A)
(350 x 394mm)

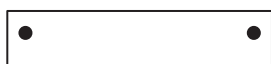

7 Rail (D1827A)
(350 x 75mm) x 2

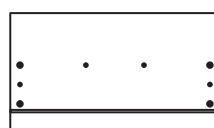

8 Drawer Front (D1828A)
(346 x 196mm) x 2



9 Drawer Back (W550)
(301 x 115mm) x 2



10 Left Drawer Side (W509LH)
(330 x 115mm) x 2



11 Right Drawer Side (W509RH)
(330 x 115mm) x 2



12 Drawer Base (T550)
(312 x 327mm) x 2



13 Back (X922)
(221 x 378mm)











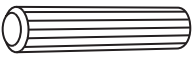
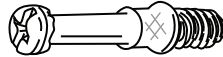

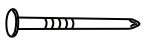
Components - Fittings

If you have damaged or missing components, call the **Customer Helpline: 08456 400800** quoting the reference numbers below

Please check you have all the fittings listed below

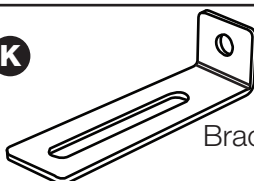
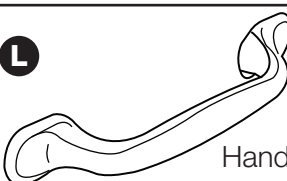
Note: The quantities below are the correct amount to complete the assembly. In some cases more fittings may be supplied than are required.

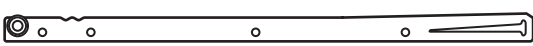
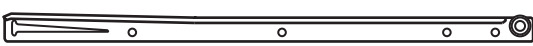
<p>A </p> <p>Wooden dowel (F22) x 4</p>	<p>B </p> <p>Metal dowel (F901) x 22</p>	<p>C </p> <p>Large locking nut (F900) x 18</p>
<p>D </p> <p>Small locking nut (F3) x 4</p>	<p>E </p> <p>Nail (F51) x 8</p>	<p>F </p> <p>Knock-in Peg (F171) x 8</p>
<p>G </p> <p>19mm Screw (F461) x 4</p>	<p>H </p> <p>13mm Screw (F63) x 12</p>	<p>I </p> <p>13mm Screw (F79) x 1</p>
<p>J </p> <p>13mm Screw (F52) x 12</p>	<p>K </p> <p>Bracket (F327) x 1</p>	<p>L </p> <p>Handle (F287) x 2</p>
<p>M a  L Runner (F159) x 2</p> <p>M b  R Runner (F160) x 2</p> <p>M c  L Runner (F161) x 2</p> <p>M d  R Runner (F162) x 2</p>		

Ruler - Use this ruler to help correctly identify the screws

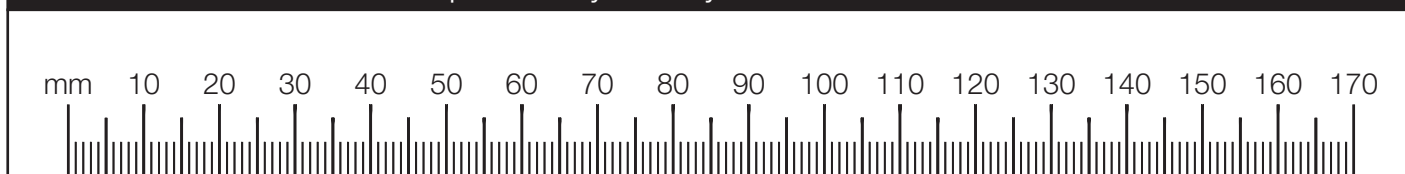

Assembly Instructions

If you have damaged or missing components, call the
Customer Helpline: 08456 400800 quoting the reference
numbers below

Step 1

Prepare the 2 drawer fronts

Screw 2 metal dowels **B** into the holes shown on the back of each drawer front **8**.

Note: Tighten metal dowels up fully against the panels.

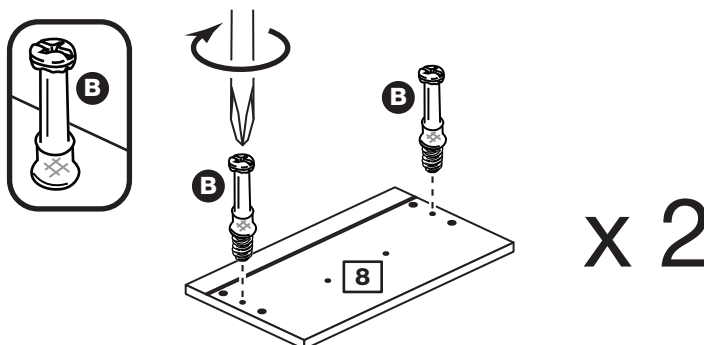

Step 2

Prepare the drawer sides

Insert a small locking nut **D** into the hole shown on the left drawer side **10** and right drawer side **11**.

Note: Arrow on locking nut **must** point towards hole in edge of panel.

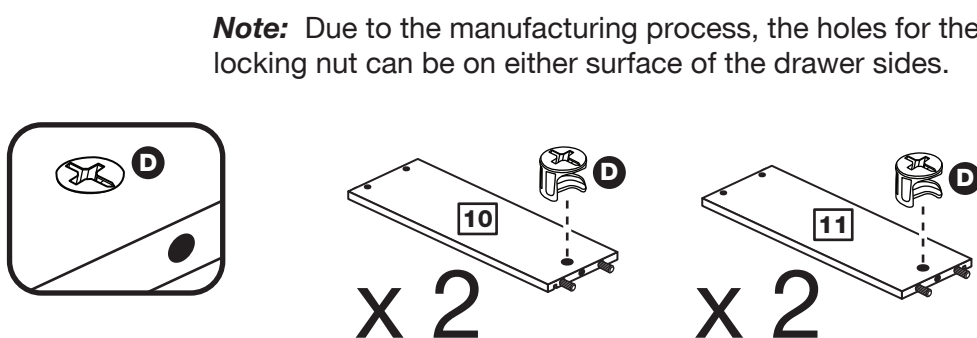

Step 3

Attach the drawer sides to the drawer front

Push the left drawer side **10** and right drawer side **11** onto the back of the drawer front **8**.

Turn the small locking nuts **D** on the left drawer side **10** and right drawer side **11**.

Note: Turn the locking nuts **D** clockwise to secure panels - more than 1/2 a turn.

Note: The locking nuts can be on either surface of the drawer sides. Make sure that the groove is on the inside, as shown.

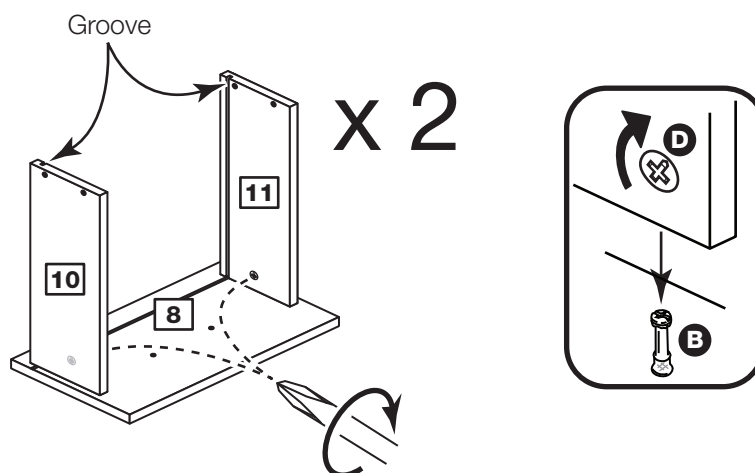

Assembly Instructions

Step 4

Fit the drawer base

Slide the drawer base **12** down the grooves in the drawer sides **10** and **11** and down into the groove in the drawer front **8**.

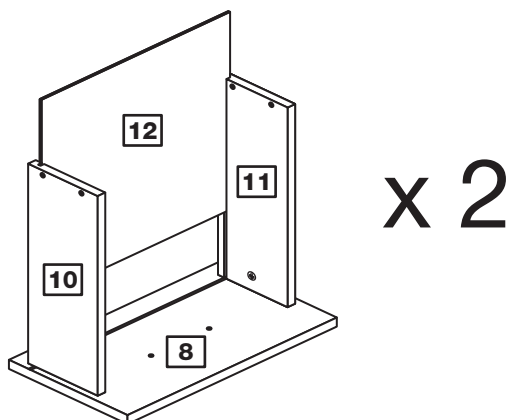

Step 5

Fit the drawer back

Fit the drawer back **9** between the drawer sides **10** and **11**.

Make sure that the drawer base **12** fits into the groove in the drawer back **9**.

Hold the drawer back **9** in position and tap the knock-in pegs **F** through the holes in the drawer sides **10** and **11**.

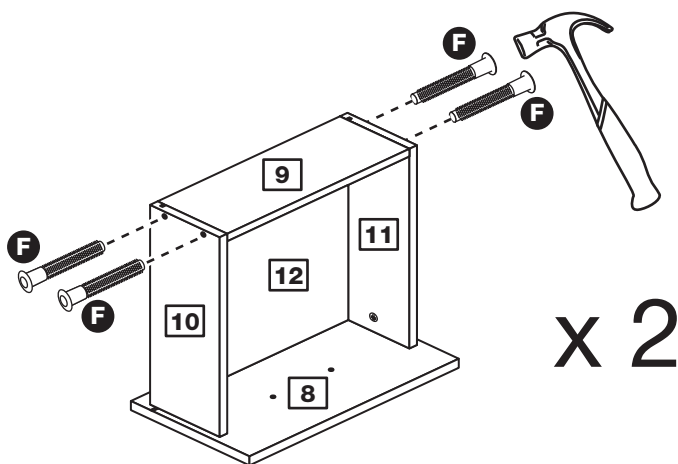

Step 6

Attach the handles

Attach a handle **L** to each drawer front **8** using 2 screws **G**.

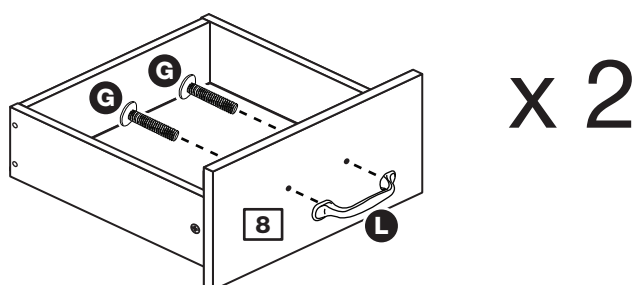

Assembly Instructions

Step 7

Fit runners to the drawers

Turn the 2 drawer assemblies over.

Fit runner **Md**, marked with 'R', to the bottom edge of the right drawer side **11**, as shown, making sure that it is pushed up against the back of the drawer front **8**. Use a bradawl to mark the fixing positions, then secure with 2 screws **H**.

Fit runner **Mc**, marked 'L', to the bottom edge of the left drawer side **10** using the same method.

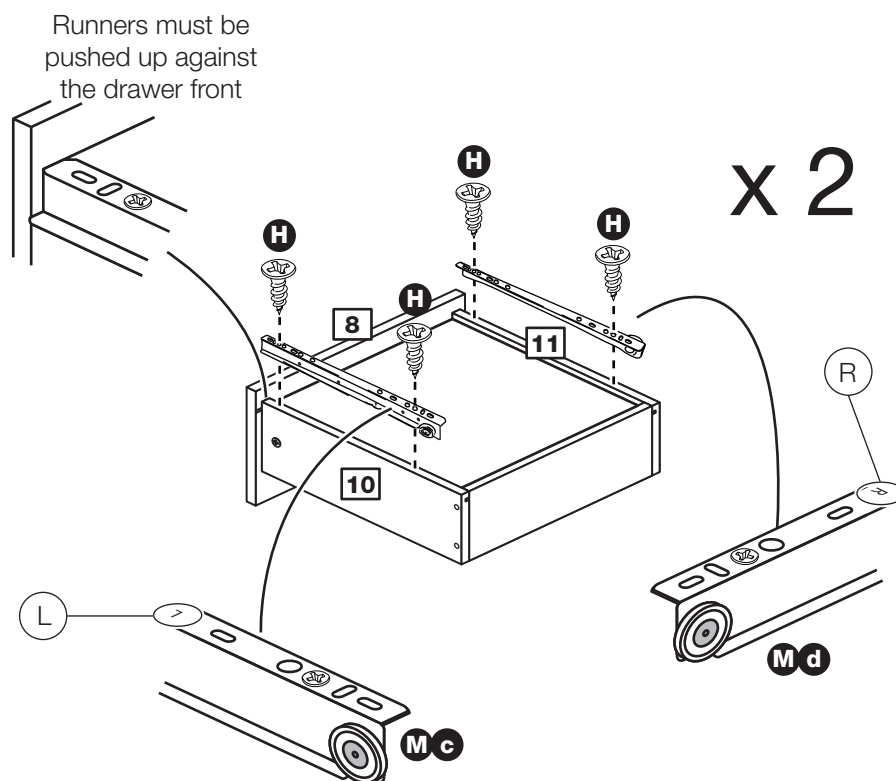

Step 8

Prepare the shelf

Insert 4 large locking nuts **C** into the shelf **6**.

Note: The arrow on the locking nut **must** point towards the hole in the edge of the panel.

Fix the bracket **K** in the middle of the shelf **6**, flush to the back edge, using screw **I**.

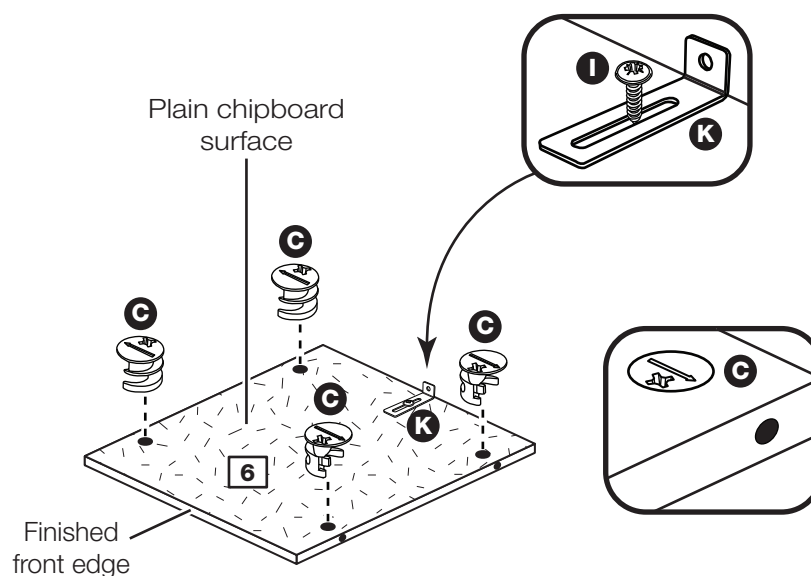

Assembly Instructions

Step 9

Prepare the upright

a: Fit 2 runners **M b** to the upright **3**.

The 1st screw **J** uses the 2nd hole in from the front of the runner.

The 2nd and 3rd screws **J** use the holes that line up with the other panel holes.

b: Fit a screw **H** into the 2nd hole in at the top of the 2 runners **M b**.

Screw 4 metal dowels **B** into the upright **3**.

Insert 2 large locking nuts **C** into the upright **3**.

Turn the divider over

c: Screw 2 metal dowels **B** into the upright **3**.

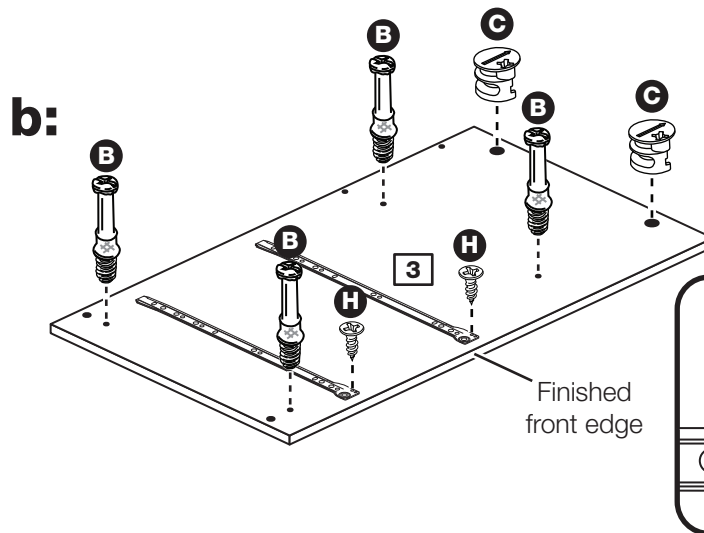
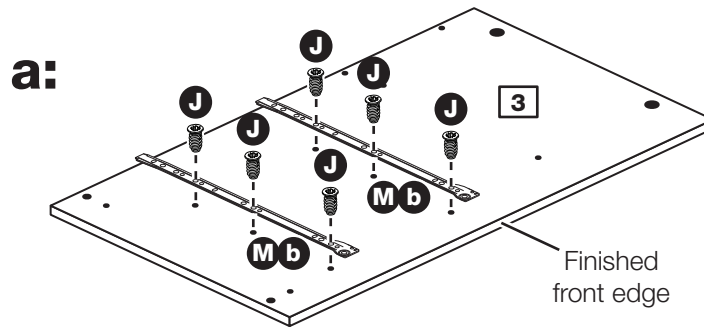
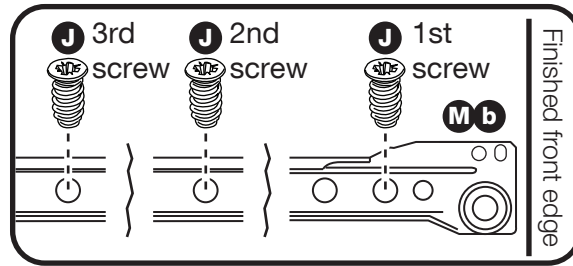

Turn the upright over

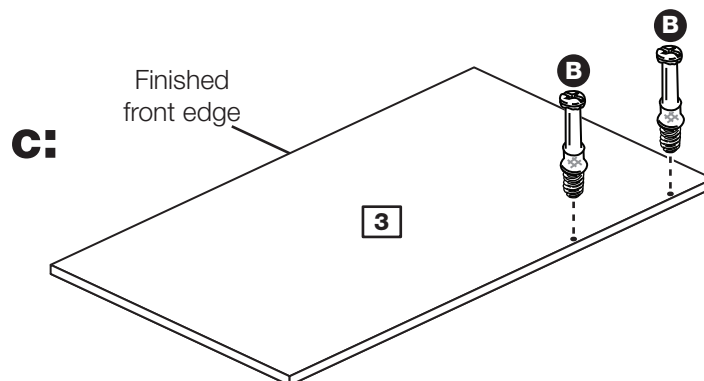
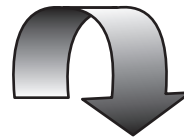

Assembly Instructions

Step 10

Join the shelf to the upright

Push the shelf **6** onto the upright **3**.

Use a screwdriver to tighten the 2 large locking nuts **C** fitted to the shelf **3**.

Note: Turn the large locking nuts **C** as far as they will go - more than 1/2 a turn.

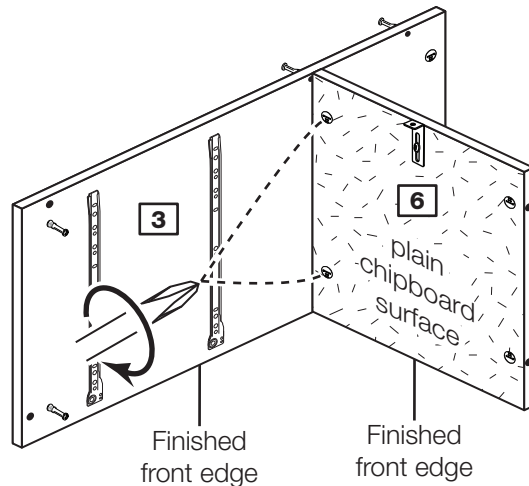

Step 11

Prepare the left end

a: Fit 2 runners **Ma** to the left end **1**.

The 1st screw **J** uses the 2nd hole from the front of the runner.

The 2nd screw **J** uses the hole that lines up with the other panel hole.

b: Fit a screw **H** into the 2nd hole in at the top of the 2 runners **Ma**.

Screw 4 metal dowels **B** into the left end **1**.

Insert 2 large locking nuts **C** into the left end **1**.

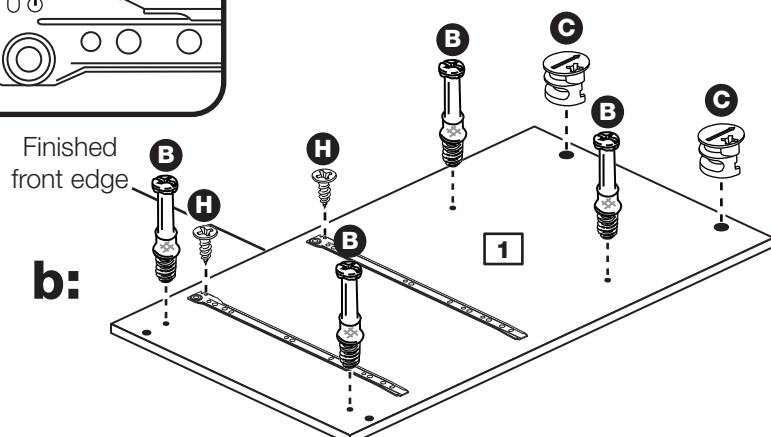
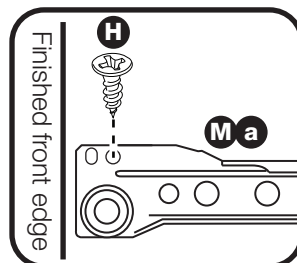
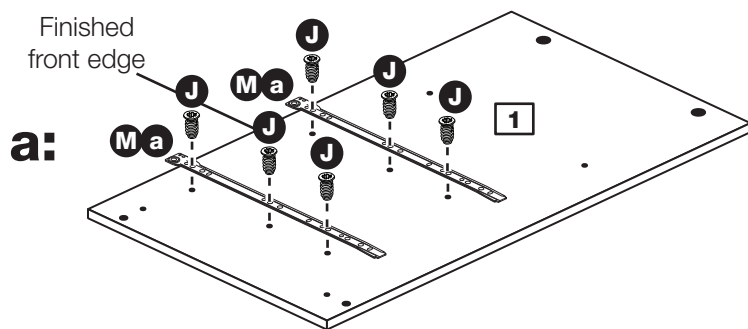
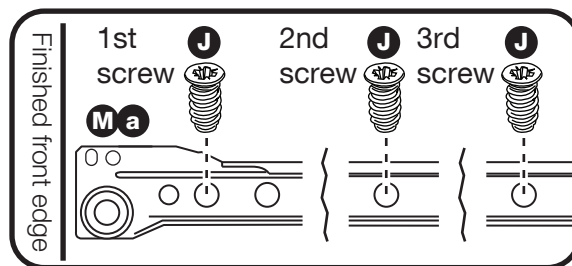

Assembly Instructions

Step 12

Prepare the 2 rails

Tap 2 wooden dowels **A** into each of the rails **7**.

Note: Wooden dowels **must not** stick out from the edge by more than 10mm or they may damage other panels.

Insert 2 large locking nuts **C** into each of the rails **7**.

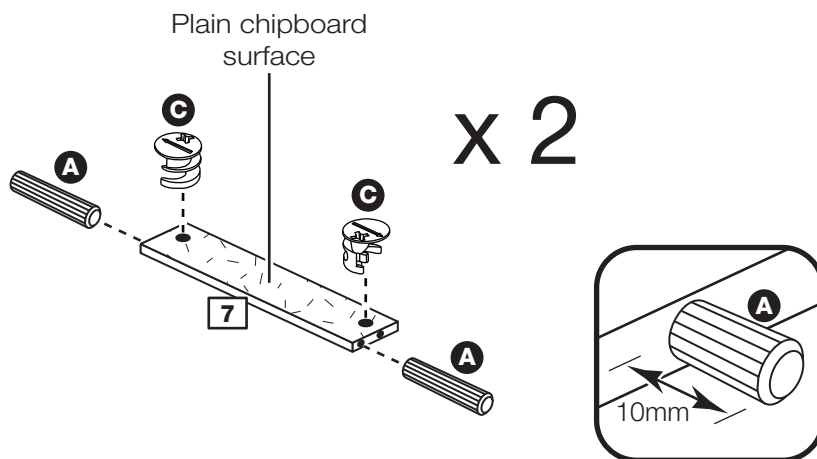

Step 13

Fit the rails

Push the 2 rails **7** onto the upright **3**.

Use a screwdriver to tighten the 2 large locking nuts **C** fitted to the rails **7**.

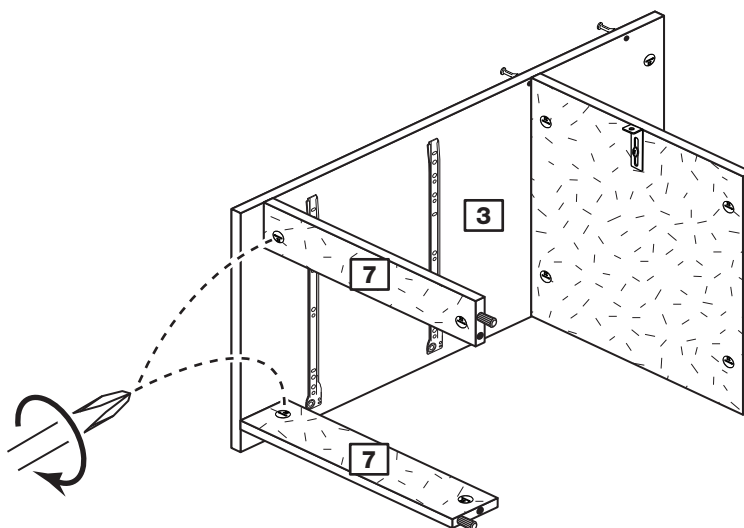

Step 14

Fit the left side

Push the left side **1** onto the shelf **6** and rails **7**.

Use a screwdriver to tighten the 4 large locking nuts **C** fitted to the shelf **6** and the rails **7**.

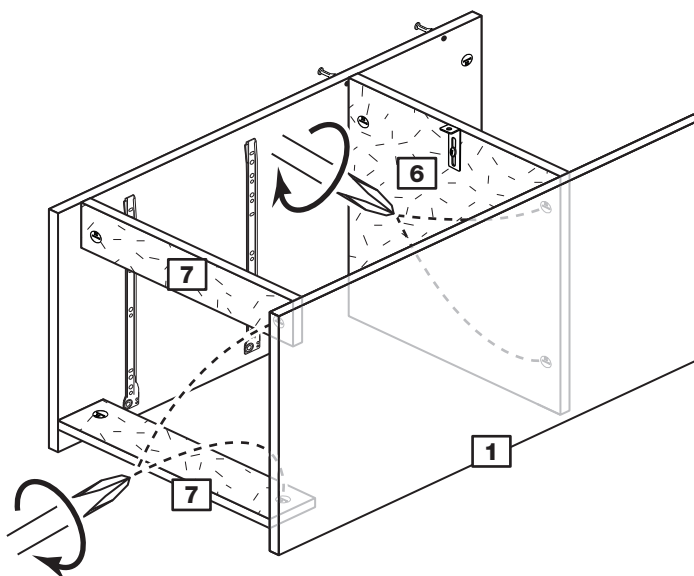

Assembly Instructions

Step 15

Prepare the right end

Screw 2 metal dowels **B** into the right end **2**.

Insert 2 large locking nuts **C** into the right end **2**.

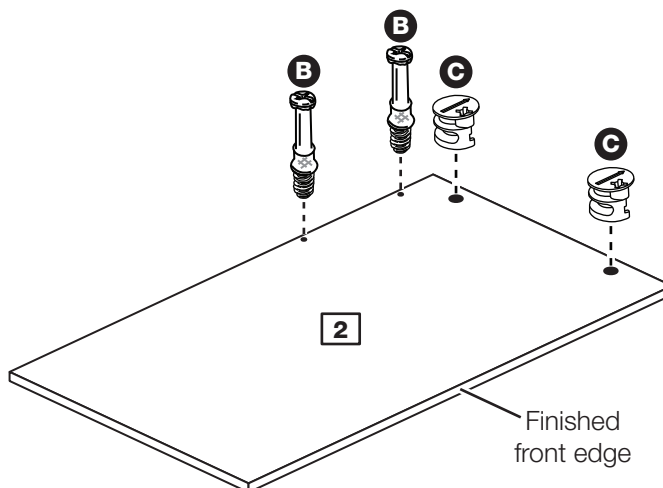

Step 16

Prepare the modesty

Insert 4 large locking nuts **C** into the modesty **5**.

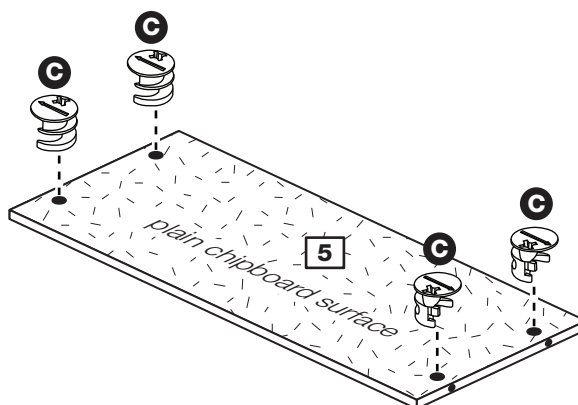

Step 17

Fit the modesty

Push the modesty **5** onto the upright **3**.

Use a screwdriver to tighten the 2 large locking nuts **C** fitted to the modesty **5**.

Note: Support the modesty until the right end has been fitted in the next step.

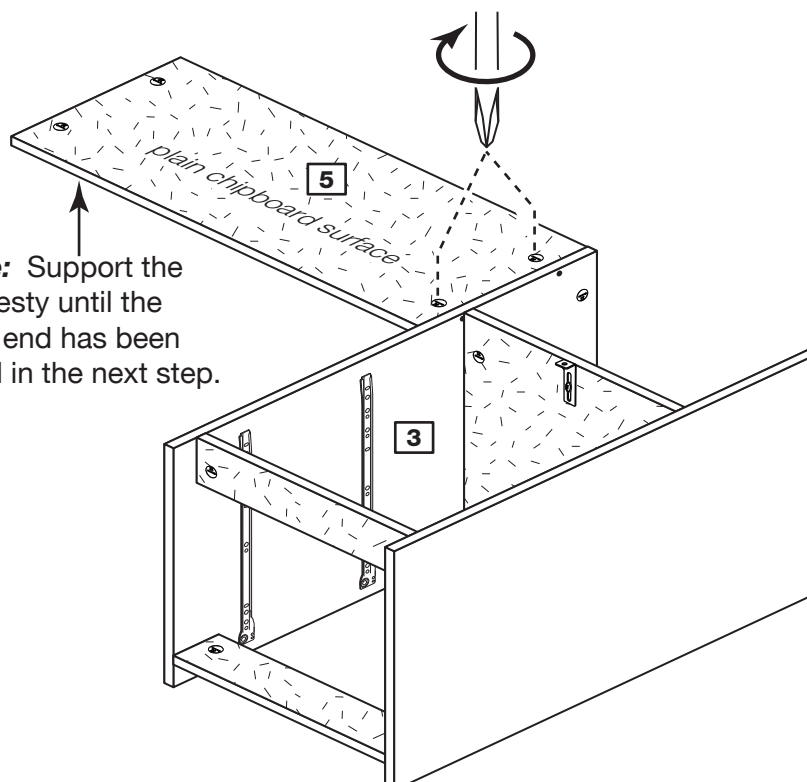

Assembly Instructions

Step 18

Fit the right end

Push the right end **2** onto the modesty **5**.

Use a screwdriver to tighten the 2 large locking nuts **C** fitted to the modesty **5**.

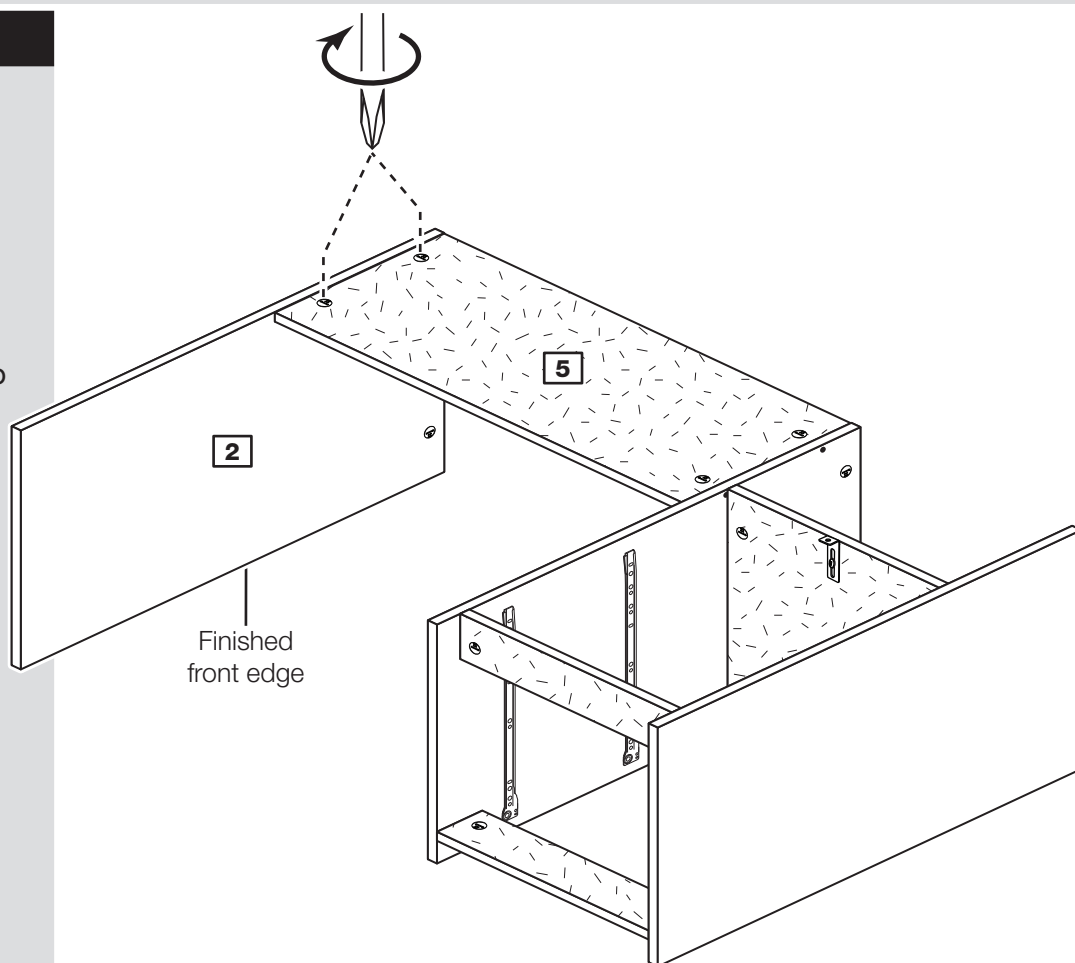

Step 19

Prepare the top

Screw 6 metal dowels **B** into the top **4**.

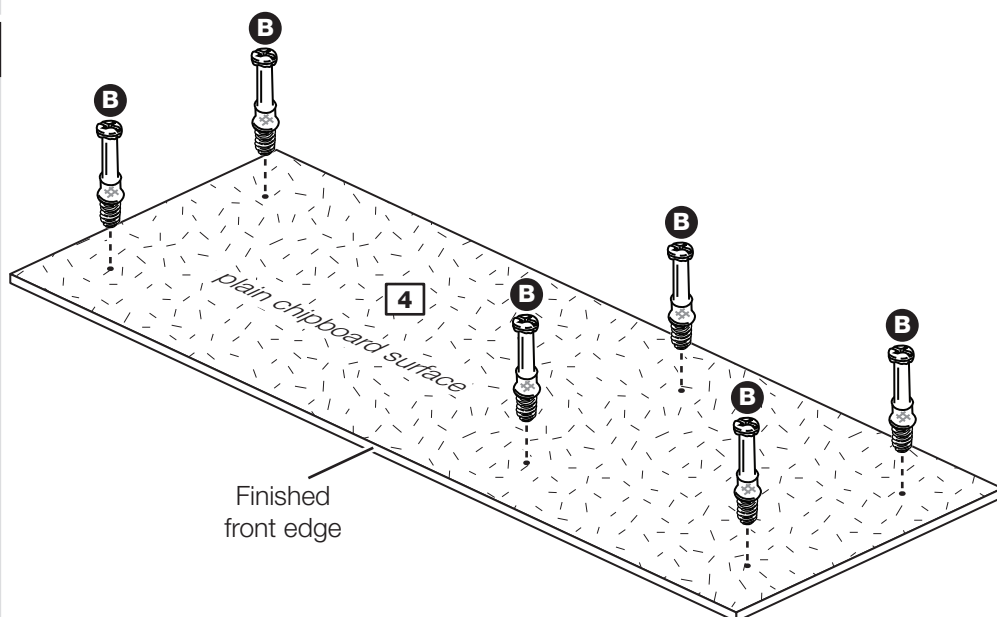

Assembly Instructions

Step 20

Fit the top

Carefully stand the unit up for this step.

Push the top **4** down onto the assembly.

Use a screwdriver to tighten the 6 large locking nuts **C** fitted to the left end **1**, the right end **2** and the upright **3**.



Warning: The unit is heavy. Lift with care.

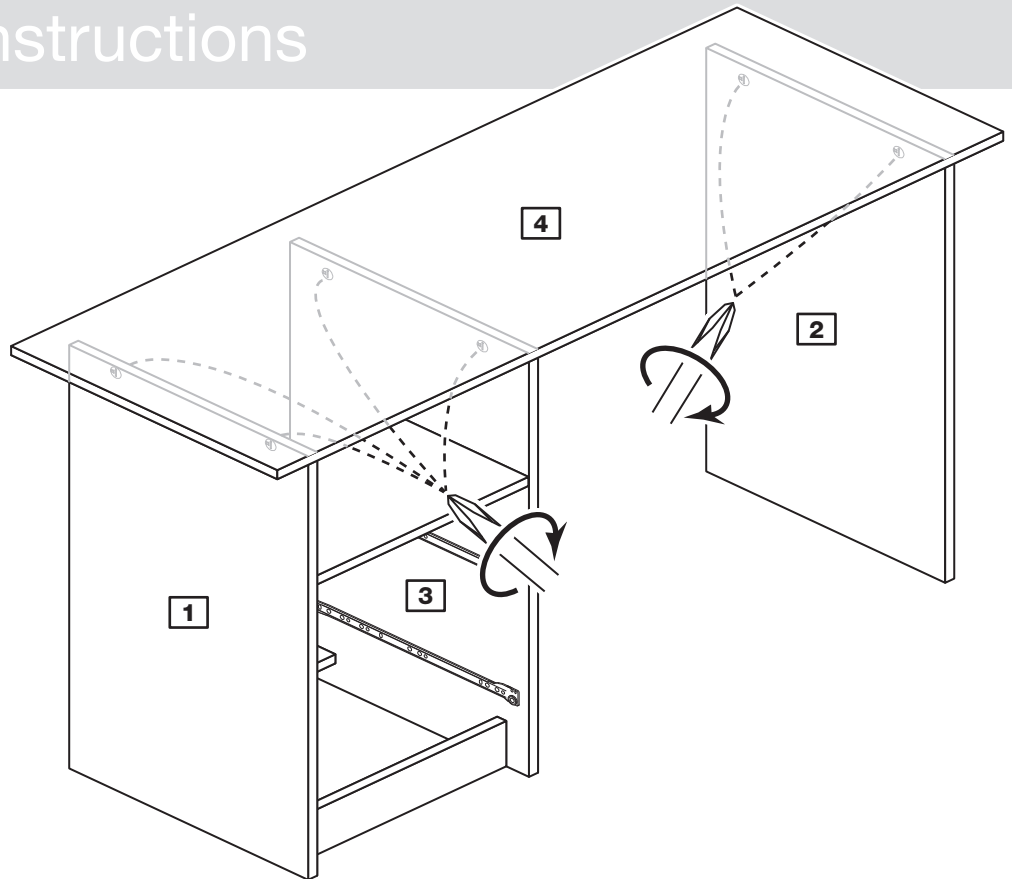

Step 21

Fit the back

Lay the unit back down for this step.

a: Square up the unit by making sure that measurement **x to x** equals **y to y**.

b: Place the back **13** onto the unit.

Nail **E** through the back **13** onto the edge of the left end **1**, upright **3** and shelf **6**.

Note: Nails should be evenly spaced out.

Stand the unit up for the next step.

a: The measurement from top corner X to bottom corner X must be equal to the measurement from top corner Y to bottom corner Y

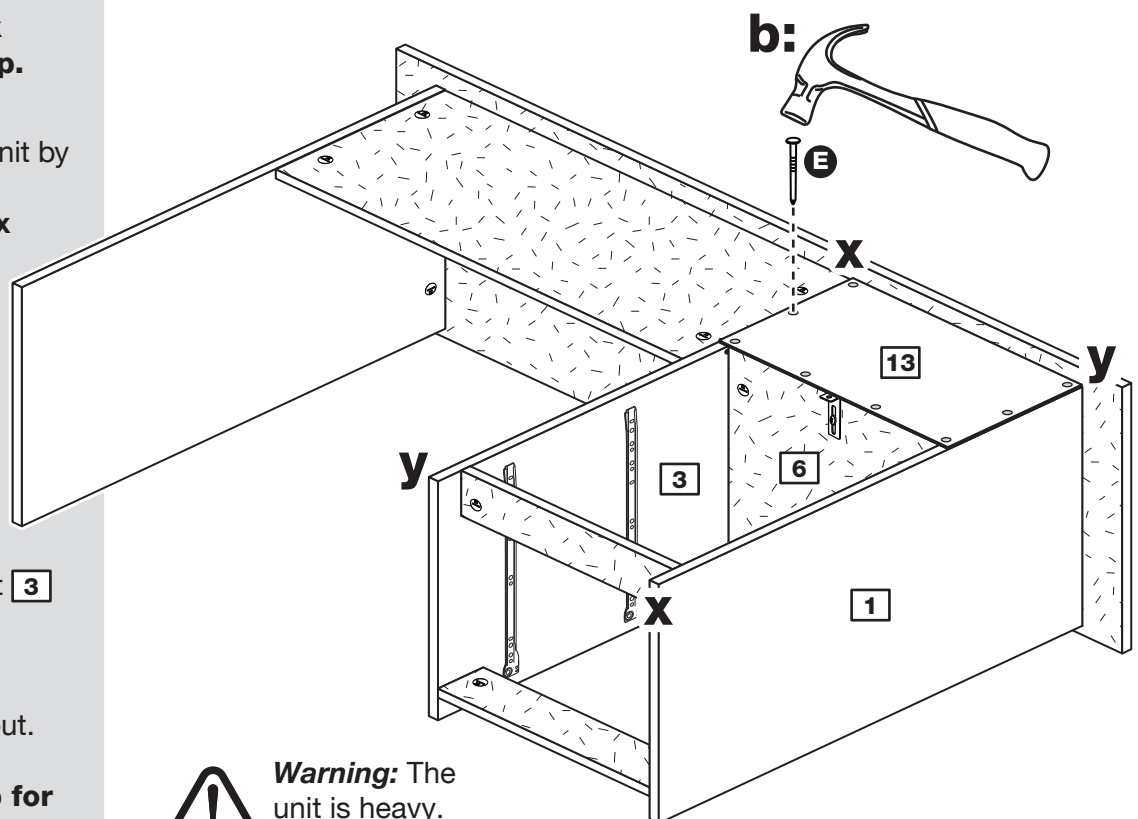

Warning: The unit is heavy. Lift with care.

Assembly Instructions

Step 22

Secure unit to a wall

To prevent possible overbalancing we recommend that this unit is secured to a suitable wall by use of the metal bracket **K** fitted underneath the shelf **6**.

Fixings are not supplied as they will need to suit the wall type, and the length of screw will depend on the distance of the back of the unit to the wall.

 **Warning:** Take care when drilling the wall that you do not drill into any pipes, wires etc. If in doubt, consult an expert.



Warning: The unit is heavy. Lift with care.

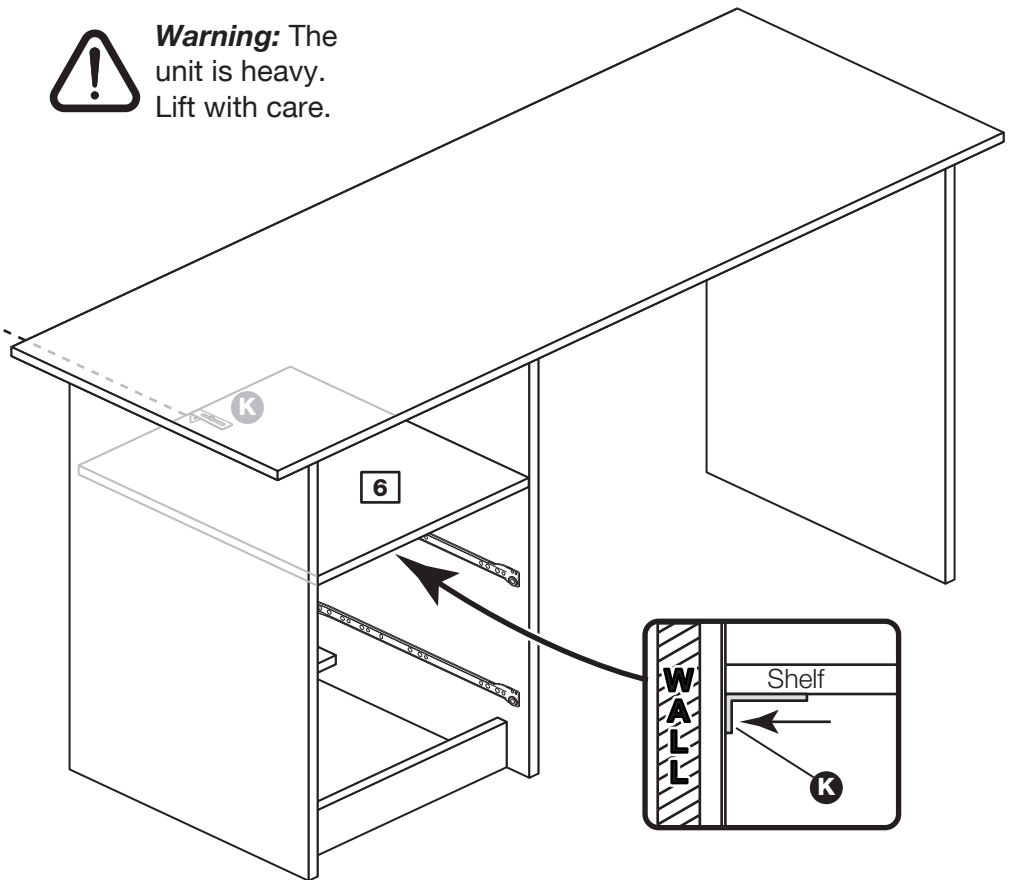

Assembly Instructions

Step 23

Fit the drawers

Slide the wheels of the runners fitted to the drawers, over the wheels of the runners fitted to the side panels and push the drawers into position.

Assembly is complete



Warning: The unit is heavy. Lift with care.

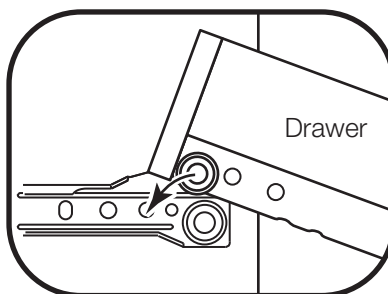
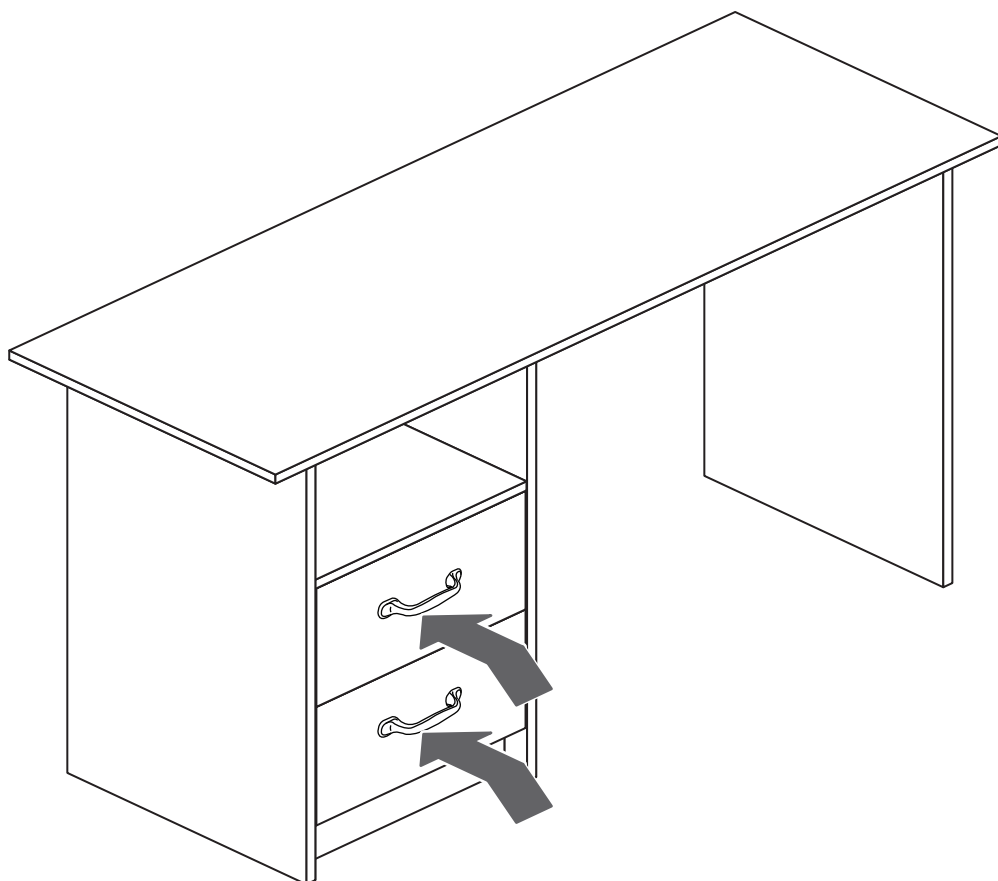

If you need help or have damaged or missing parts, call the **Customer Helpline: 08456 400800** and quote the reference numbers on the component pages.

Argos Ltd, 489-499 Avebury Boulevard, Central Milton Keynes, MK9 2NW

Dalton - Pedestal Desk

Assembly Instructions - Please keep for future reference

617/3601

158/5122

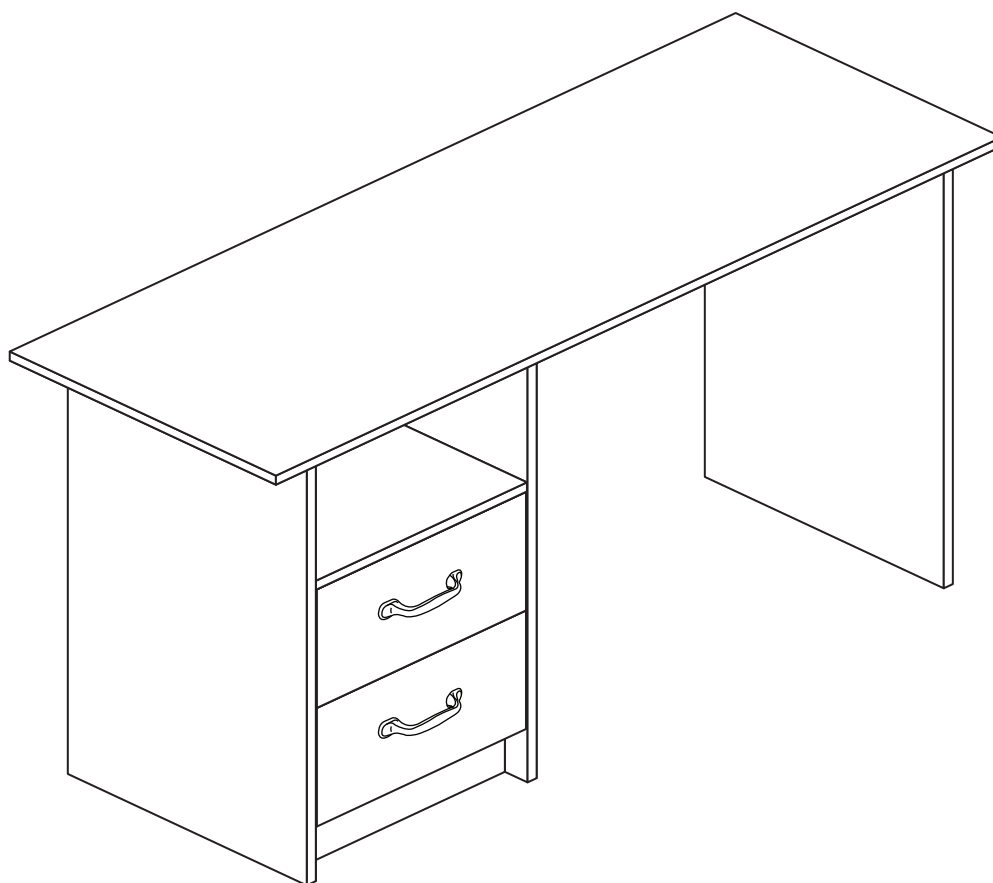

Dimensions

Width - 120cm

Depth - 44cm

Height - 71.5cm



**MADE IN
BRITAIN**

Important - Please read these instructions fully before starting assembly

If you need help or have damaged or missing parts, call the **Customer Helpline: 03456 400800**



Safety and Care Advice

Important - Please read these instructions fully before starting assembly

- **Warning:** This unit weighs approximately 23kgs. Please lift with care.

- Check you have all the components and tools listed on pages 2 and 3.

- Remove all fittings from the plastic bags and separate them into their groups.

- Keep children and animals away from the work area, small parts could choke if swallowed.

- Parts of the assembly will be easier with 2 people.

- Make sure you have enough space to layout the parts before starting.

- Do not stand or put weight on the product, this could cause damage.

- Assemble the item as close to its final position (in the same room) as possible.

- Assemble on a soft level surface to avoid damaging the unit or your floor (use opened out unit carton).



- We do not recommend the use of power drill/drivers **for inserting screws**, as this could damage the unit. Only use hand screwdrivers.

- **Safety note:** It is recommended that this unit is secured to a wall using the overbalance protector kit supplied or, an alternative fixing method of your choice.

- Dispose of all packaging carefully and responsibly.

Care and maintenance

- Only clean using a damp cloth and mild detergent, do not use bleach or abrasive cleaners.

- From time to time check that there are no loose screws on this unit.

- This product should not be discarded with household waste. Take to your local authority waste disposal centre.

Note: If required the next page can be cut out and used as reference throughout the assembly. Keep this page with these instructions for future reference.

Components - Panels

If you have damaged or missing components, call the **Customer Helpline: 03456 400800** quoting the reference numbers below

Please check you have all the panels listed below

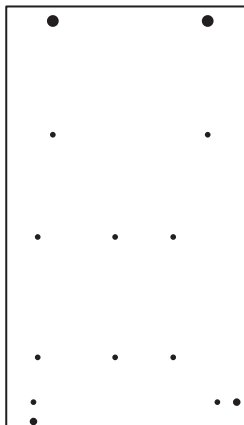

1 Left End (D1822A)
(700 x 395mm)

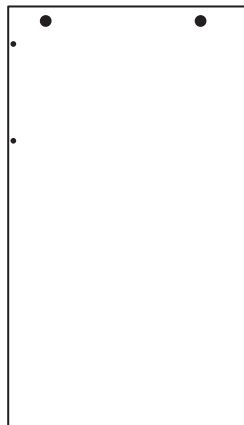

2 Right End (D1823A)
(700 x 395mm)

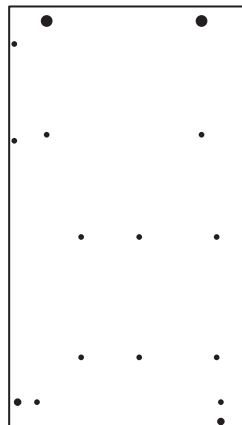

3 Upright (D1824A)
(700 x 395mm)

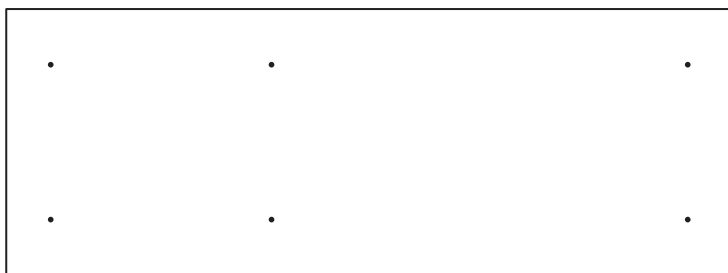

4 Top (D1821A)
(1200 x 440mm)

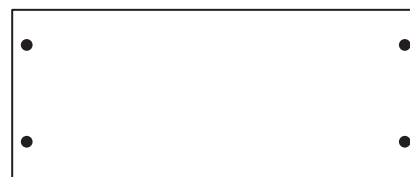

5 Modesty (D1825A)
(673 x 280mm)

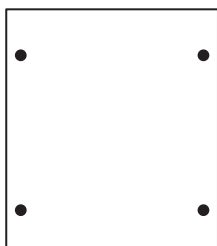

6 Shelf (D1826A)
(350 x 394mm)

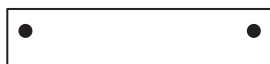

7 Rail (D1827A)
(350 x 75mm) x 2

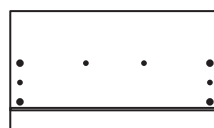

8 Drawer Front (D1828A)
(346 x 196mm) x 2



9 Drawer Back (W550)
(301 x 115mm) x 2



10 Left Drawer Side (W509LH)
(330 x 115mm) x 2



11 Right Drawer Side (W509RH)
(330 x 115mm) x 2



12 Drawer Base (T550)
(312 x 327mm) x 2



13 Back (X922)
(221 x 378mm)











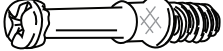

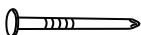

Components - Fittings

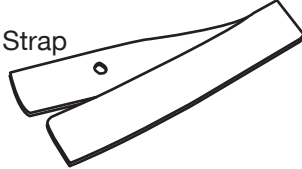
If you have damaged or missing components, call the **Customer Helpline: 03456 400800** quoting the reference numbers below

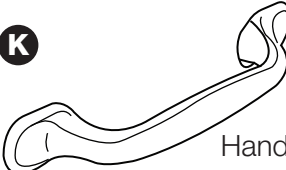
Please check you have all the fittings listed below

Note: The quantities below are the correct amount to complete the assembly. In some cases more fittings may be supplied than are required.

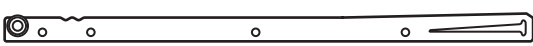
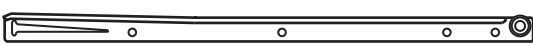
<p>A </p> <p>Wooden dowel (F22) x 4</p>	<p>B </p> <p>Metal dowel (F901) x 22</p>	<p>C </p> <p>Large locking nut (F900) x 18</p>
<p>D </p> <p>Small locking nut (F3) x 4</p>	<p>E </p> <p>Nail (F51) x 8</p>	<p>F </p> <p>Knock-in Peg (F171) x 8</p>
<p>G </p> <p>19mm Screw (F461) x 4</p>	<p>H </p> <p>13mm Screw (F63) x 12</p>	<p>I </p> <p>Strap</p>
<p>J </p> <p>13mm Screw (F52) x 12</p>	<p>K </p> <p>Handle (F287) x 2</p>	<p> Screw Washer x 2</p> <p>Overbalance protector kit (F269) x 1</p>
<p>L a  L Runner (F159) x 2</p> <p>L b  R Runner (F160) x 2</p> <p>L c  L Runner (F161) x 2</p> <p>L d  R Runner (F162) x 2</p>		

Ruler - Use this ruler to help correctly identify the screws

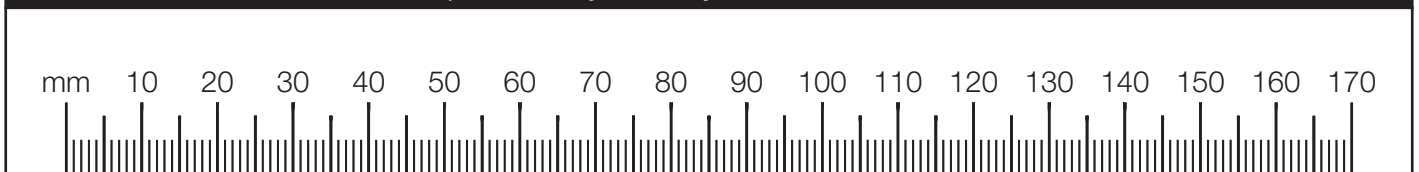

Assembly Instructions

If you have damaged or missing components, call the
Customer Helpline: 03456 400800 quoting the reference
numbers below

Step 1

Prepare the 2 drawer fronts

Screw 2 metal dowels **B** into the holes shown on the back of each drawer front **8**.

Note: Tighten metal dowels up fully against the panels.

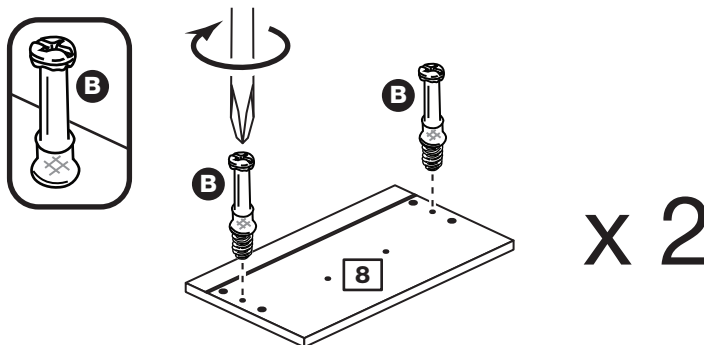

Step 2

Prepare the drawer sides

Insert a small locking nut **D** into the hole shown on the left drawer side **10** and right drawer side **11**.

Note: Arrow on locking nut **must** point towards hole in edge of panel.

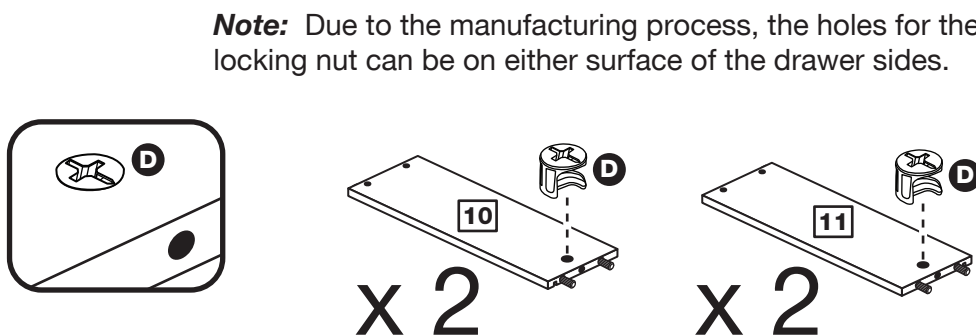

Step 3

Attach the drawer sides to the drawer front

Push the left drawer side **10** and right drawer side **11** onto the back of the drawer front **8**.

Turn the small locking nuts **D** on the left drawer side **10** and right drawer side **11**.

Note: Turn the locking nuts **D** clockwise to secure panels - more than 1/2 a turn.

Note: The locking nuts can be on either surface of the drawer sides. Make sure that the groove is on the inside, as shown.

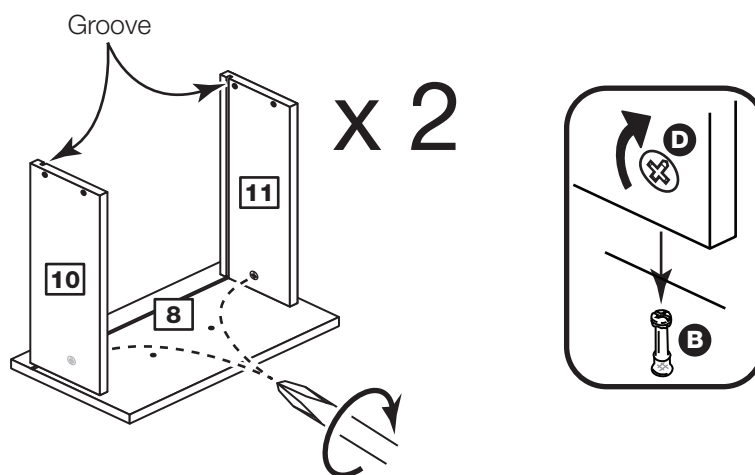

Assembly Instructions

Step 4

Fit the drawer base

Slide the drawer base **12** down the grooves in the drawer sides **10** and **11** and down into the groove in the drawer front **8**.

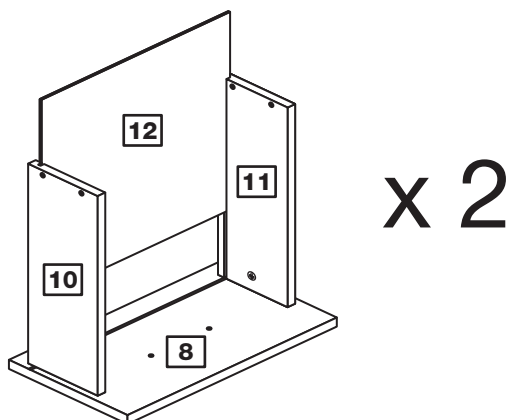

Step 5

Fit the drawer back

Fit the drawer back **9** between the drawer sides **10** and **11**.

Make sure that the drawer base **12** fits into the groove in the drawer back **9**.

Hold the drawer back **9** in position and tap the knock-in pegs **F** through the holes in the drawer sides **10** and **11**.

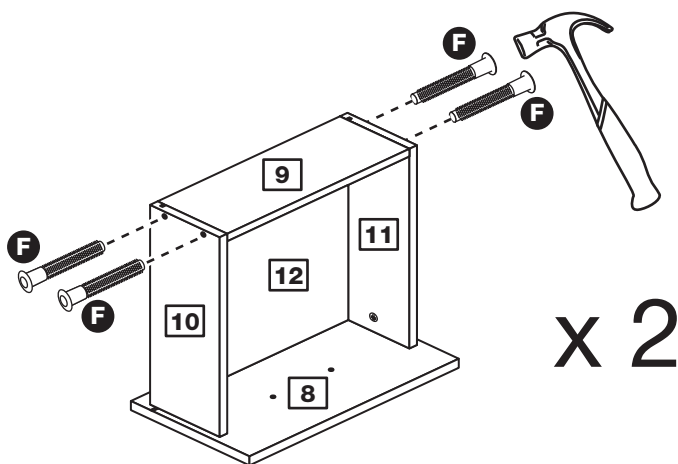

Step 6

Attach the handles

Attach a handle **K** to each drawer front **8** using 2 screws **G**.

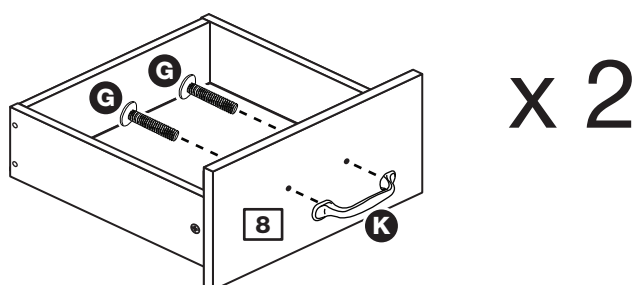

Assembly Instructions

Step 7

Fit runners to the drawers

Turn the 2 drawer assemblies over.

Fit runner **Ld**, marked with 'R', to the bottom edge of the right drawer side **11**, as shown, making sure that it is pushed up against the back of the drawer front **8**. Use a bradawl to mark the fixing positions, then secure with 2 screws **H**.

Fit runner **Lc**, marked 'L', to the bottom edge of the left drawer side **10** using the same method.

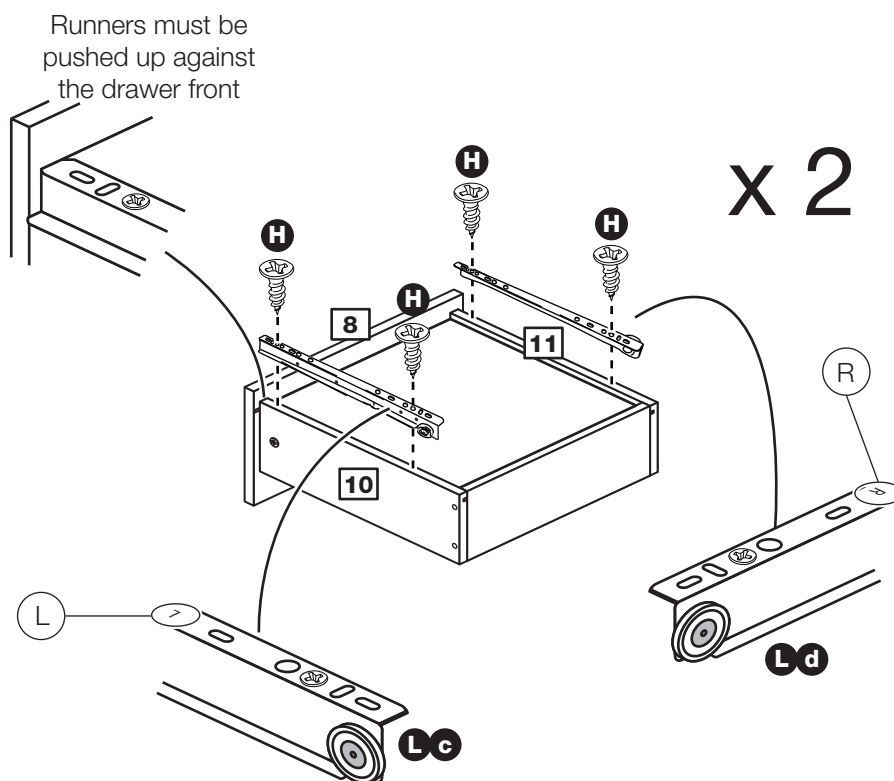

Step 8

Prepare the shelf

Insert 4 large locking nuts **C** into the shelf **6**.

Note: The arrow on the locking nut **must** point towards the hole in the edge of the panel.

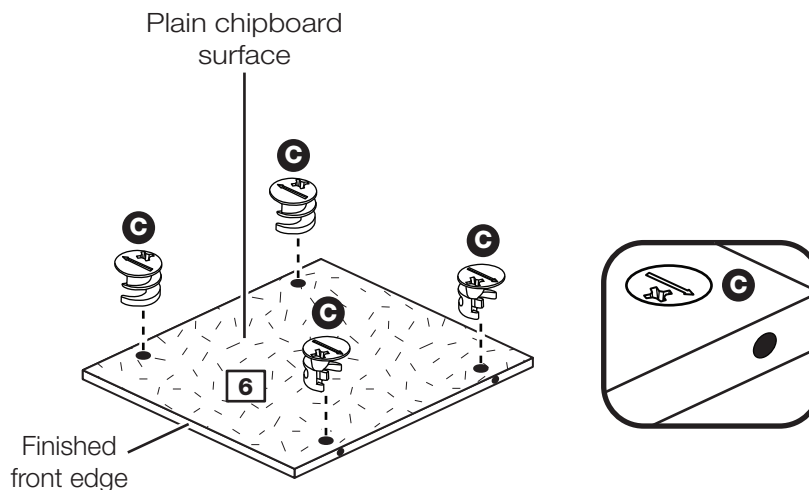

Assembly Instructions

Step 9

Prepare the upright

a: Fit 2 runners **Lb** to the upright **3**.

The 1st screw **J** uses the 2nd hole in from the front of the runner.

The 2nd and 3rd screws **J** use the holes that line up with the other panel holes.

b: Fit a screw **H** into the 2nd hole in at the top of the 2 runners **Lb**.

Screw 4 metal dowels **B** into the upright **3**.

Insert 2 large locking nuts **C** into the upright **3**.

Turn the divider over

c: Screw 2 metal dowels **B** into the upright **3**.

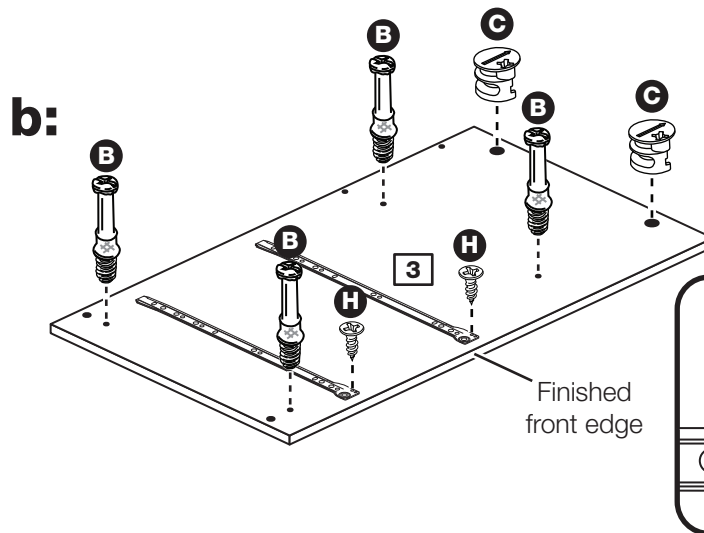
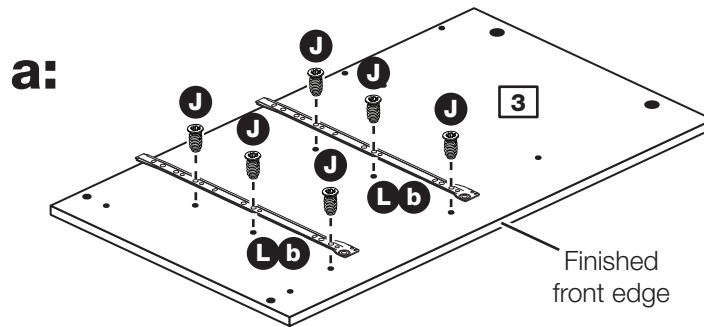
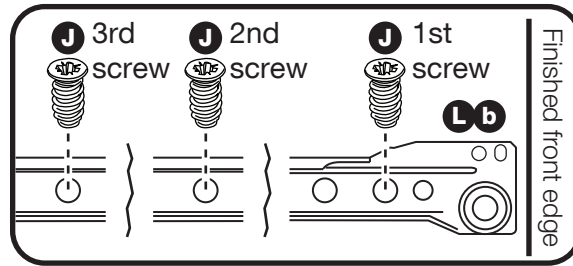

Turn the upright over

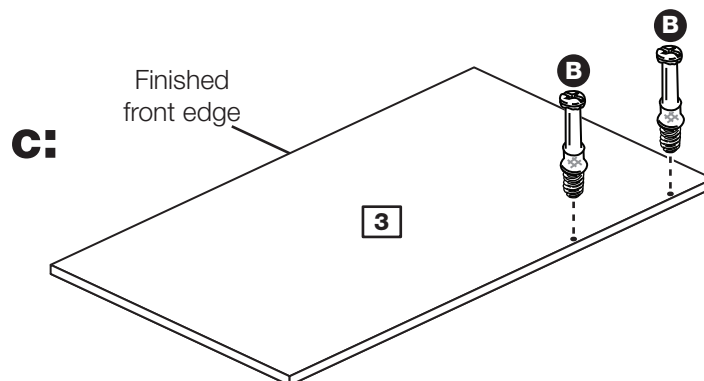
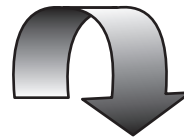

Assembly Instructions

Step 10

Join the shelf to the upright

Push the shelf **6** onto the upright **3**.

Use a screwdriver to tighten the 2 large locking nuts **C** fitted to the shelf **3**.

Note: Turn the large locking nuts **C** as far as they will go - more than 1/2 a turn.

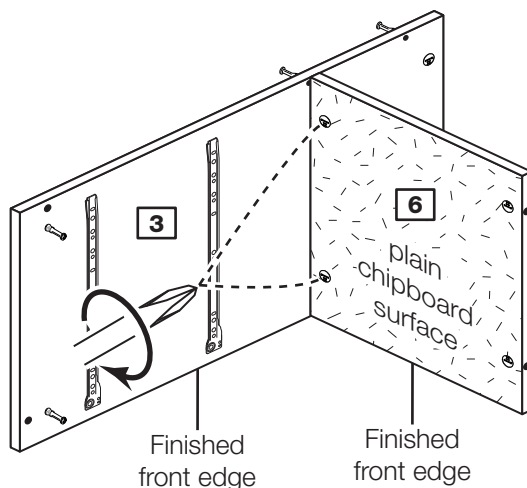

Step 11

Prepare the left end

a: Fit 2 runners **La** to the left end **1**.

The 1st screw **J** uses the 2nd hole from the front of the runner.

The 2nd screw **J** uses the hole that lines up with the other panel hole.

b: Fit a screw **H** into the 2nd hole in at the top of the 2 runners **La**.

Screw 4 metal dowels **B** into the left end **1**.

Insert 2 large locking nuts **C** into the left end **1**.

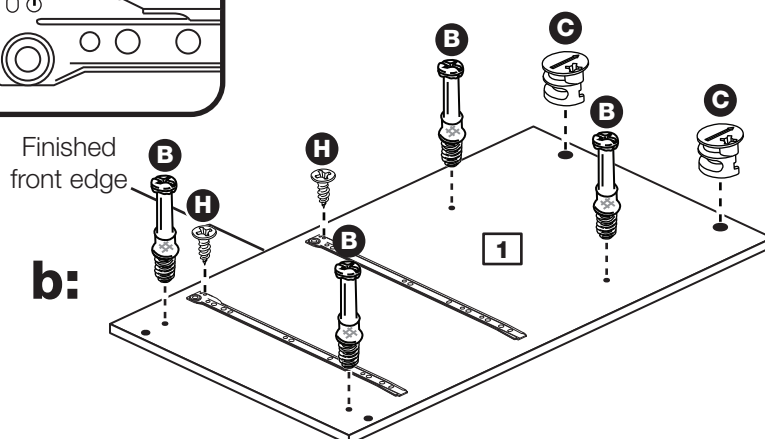
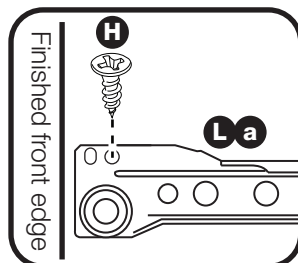
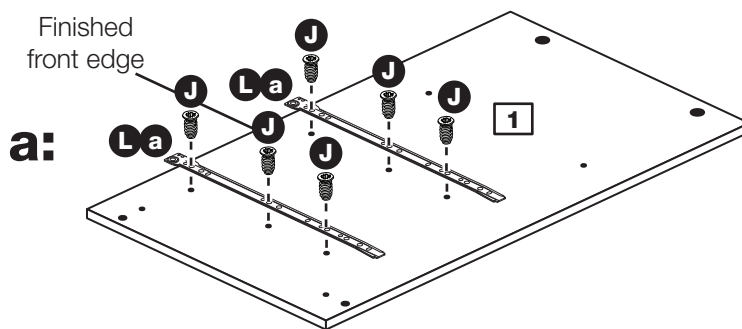
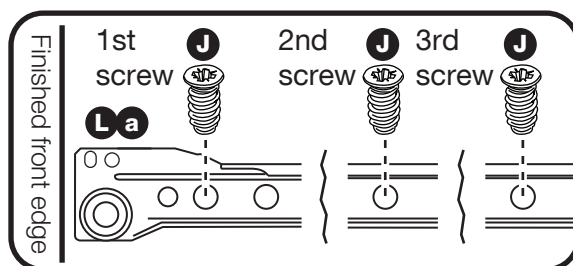

Assembly Instructions

Step 12

Prepare the 2 rails

Tap 2 wooden dowels **A** into each of the rails **7**.

Note: Wooden dowels **must not** stick out from the edge by more than 10mm or they may damage other panels.

Insert 2 large locking nuts **C** into each of the rails **7**.

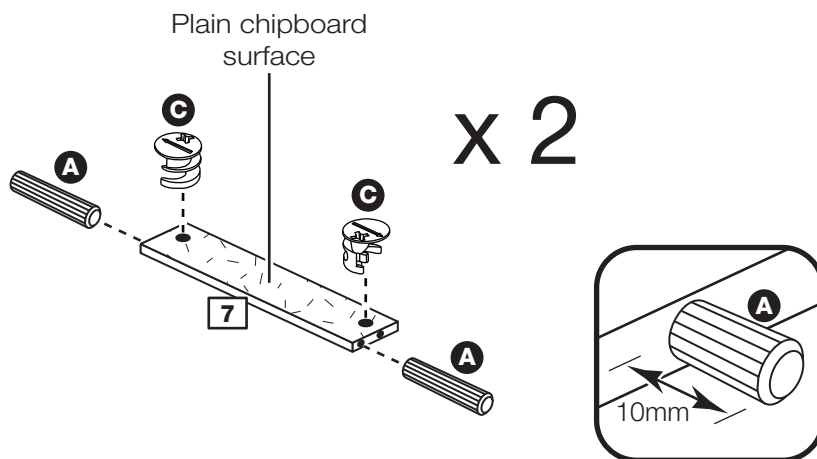

Step 13

Fit the rails

Push the 2 rails **7** onto the upright **3**.

Use a screwdriver to tighten the 2 large locking nuts **C** fitted to the rails **7**.

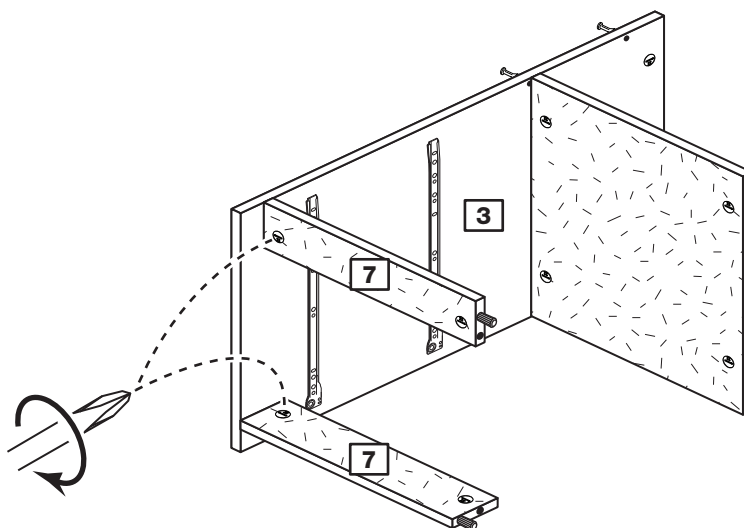

Step 14

Fit the left side

Push the left side **1** onto the shelf **6** and rails **7**.

Use a screwdriver to tighten the 4 large locking nuts **C** fitted to the shelf **6** and the rails **7**.

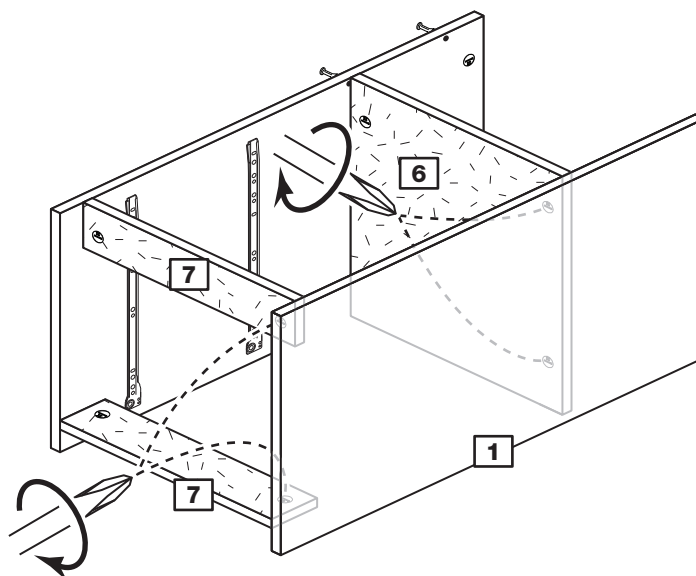

Assembly Instructions

Step 15

Prepare the right end

Screw 2 metal dowels **B** into the right end **2**.

Insert 2 large locking nuts **C** into the right end **2**.

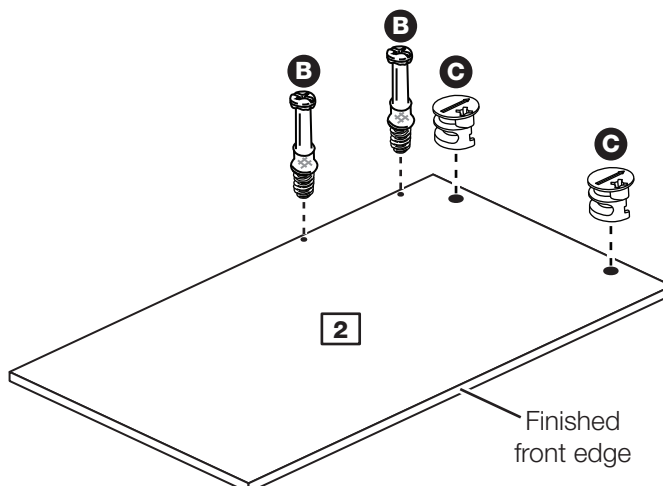

Step 16

Prepare the modesty

Insert 4 large locking nuts **C** into the modesty **5**.

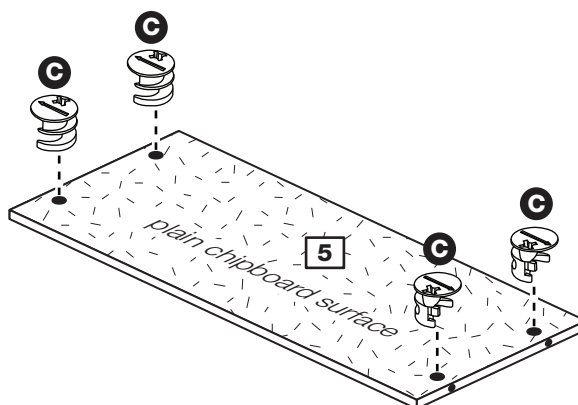

Step 17

Fit the modesty

Push the modesty **5** onto the upright **3**.

Use a screwdriver to tighten the 2 large locking nuts **C** fitted to the modesty **5**.

Note: Support the modesty until the right end has been fitted in the next step.

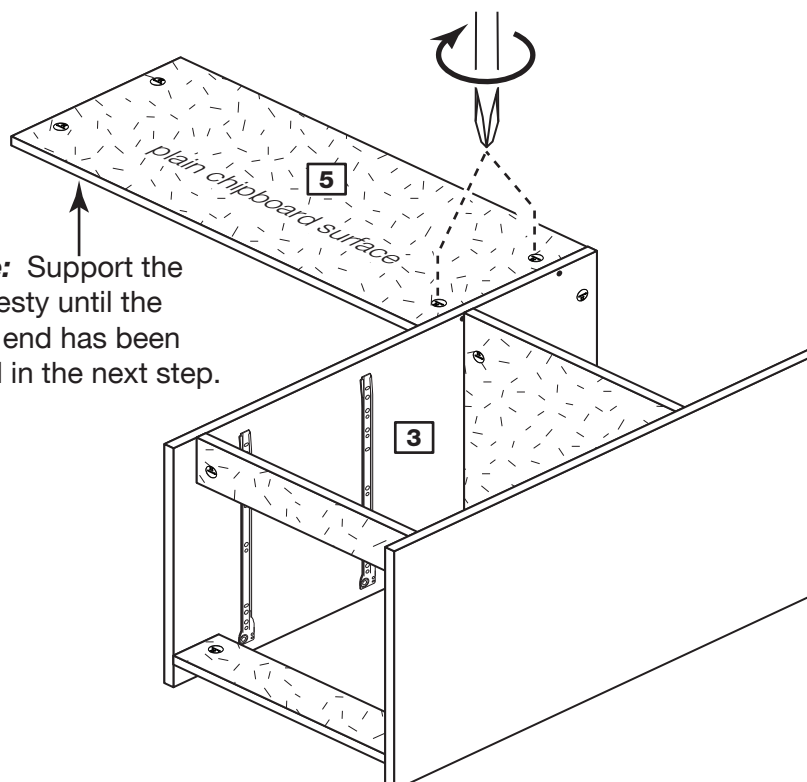

Assembly Instructions

Step 18

Fit the right end

Push the right end **2** onto the modesty **5**.

Use a screwdriver to tighten the 2 large locking nuts **C** fitted to the modesty **5**.

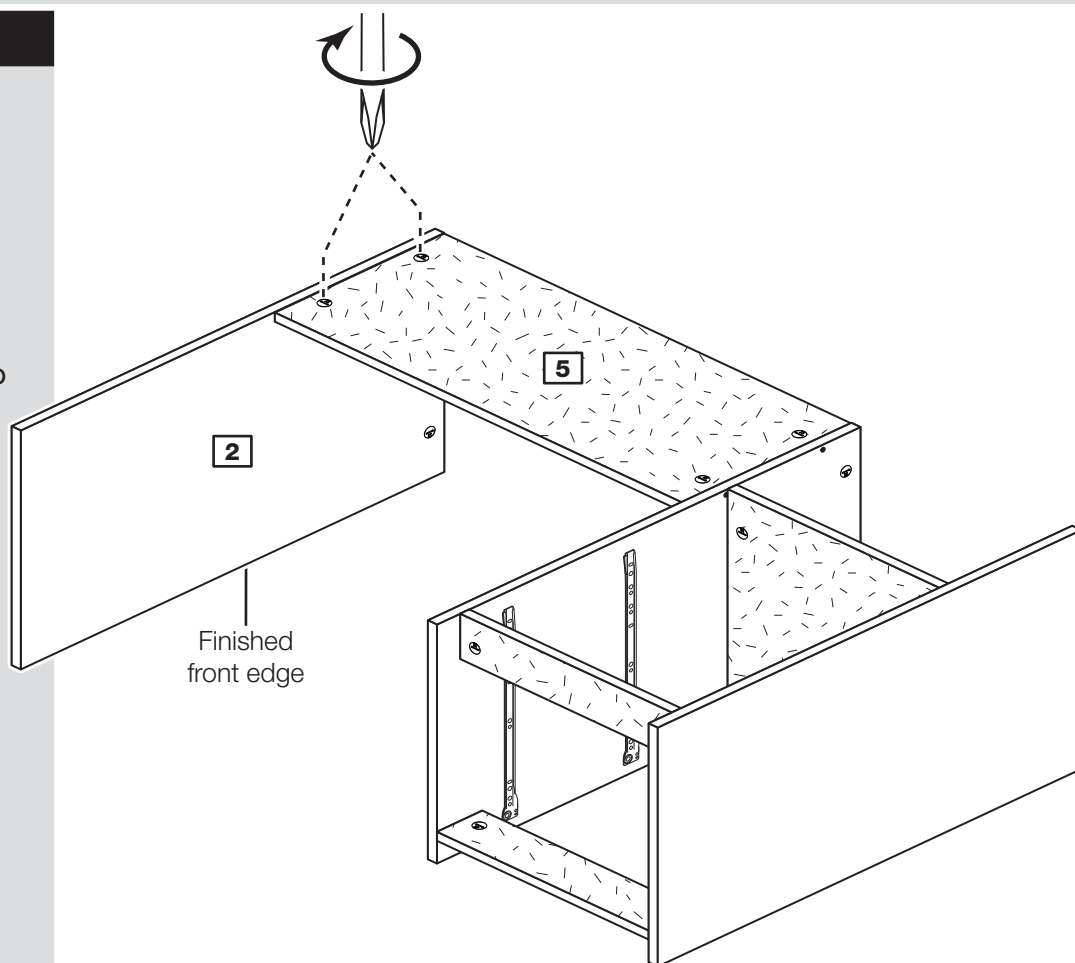

Step 19

Prepare the top

Screw 6 metal dowels **B** into the top **4**.

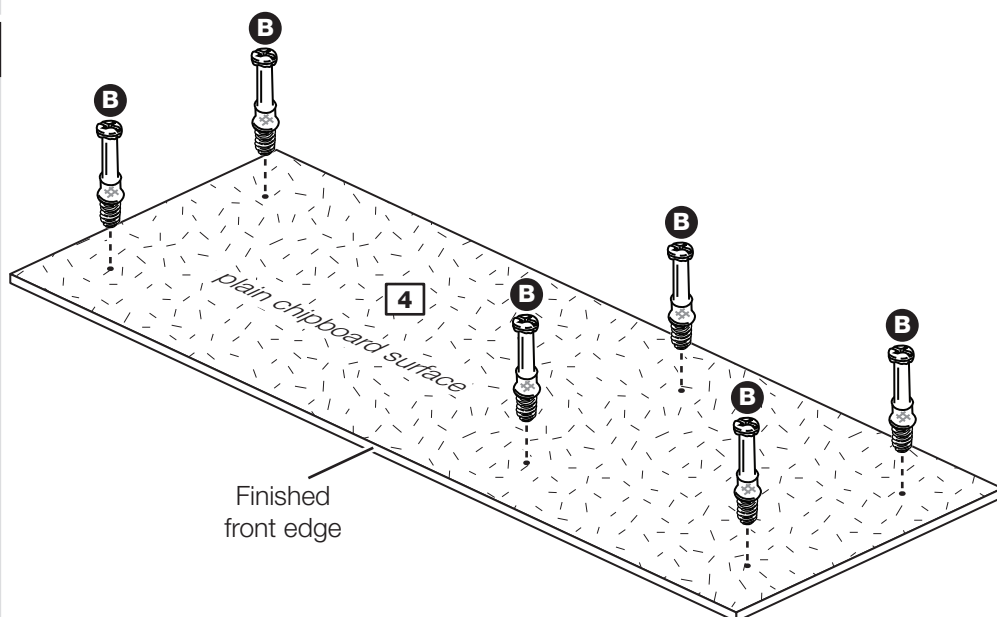

Assembly Instructions

Step 20

Fit the top

Carefully stand the unit up for this step.

Push the top **4** down onto the assembly.

Use a screwdriver to tighten the 6 large locking nuts **C** fitted to the left end **1**, the right end **2** and the upright **3**.



Warning: The unit is heavy. Lift with care.

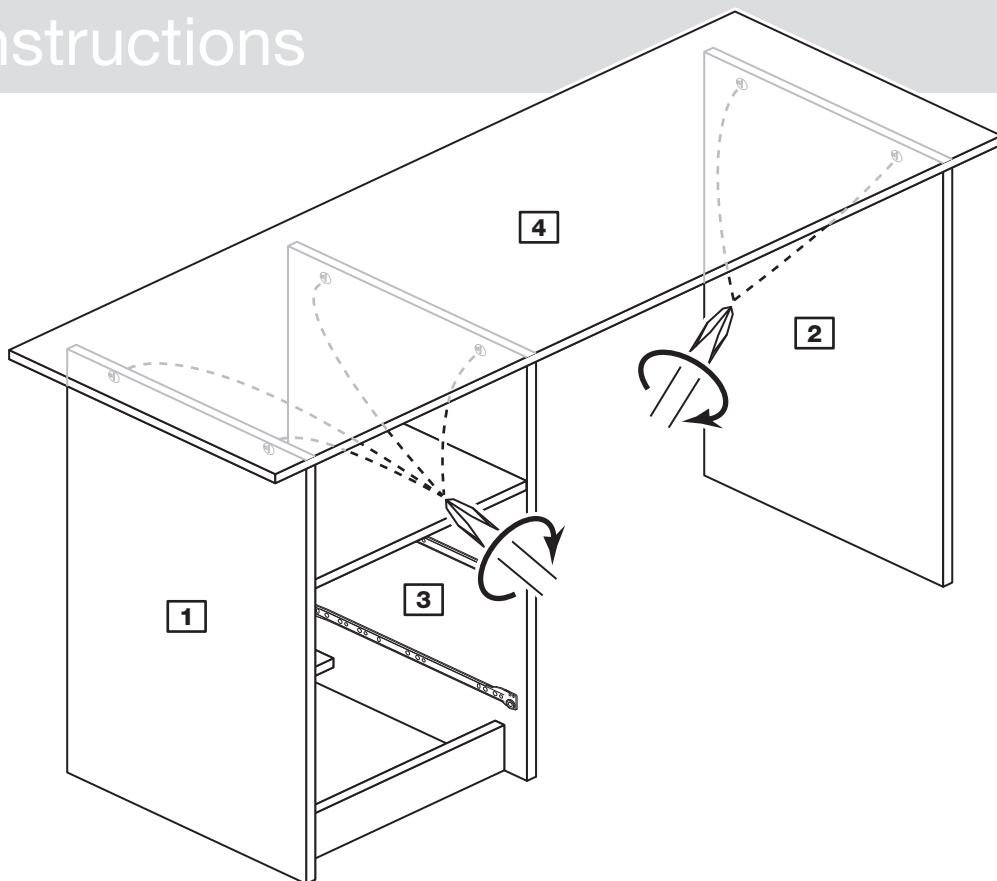

Step 21

Fit the back

Lay the unit back down for this step.

a: Square up the unit by making sure that measurement **x to x** equals **y to y**.

b: Place the back **13** onto the unit.

Nail **E** through the back **13** onto the edge of the left end **1**, upright **3** and shelf **6**.

Note: Nails should be evenly spaced out.

Stand the unit up for the next step.

a: The measurement from top corner X to bottom corner X must be equal to the measurement from top corner Y to bottom corner Y

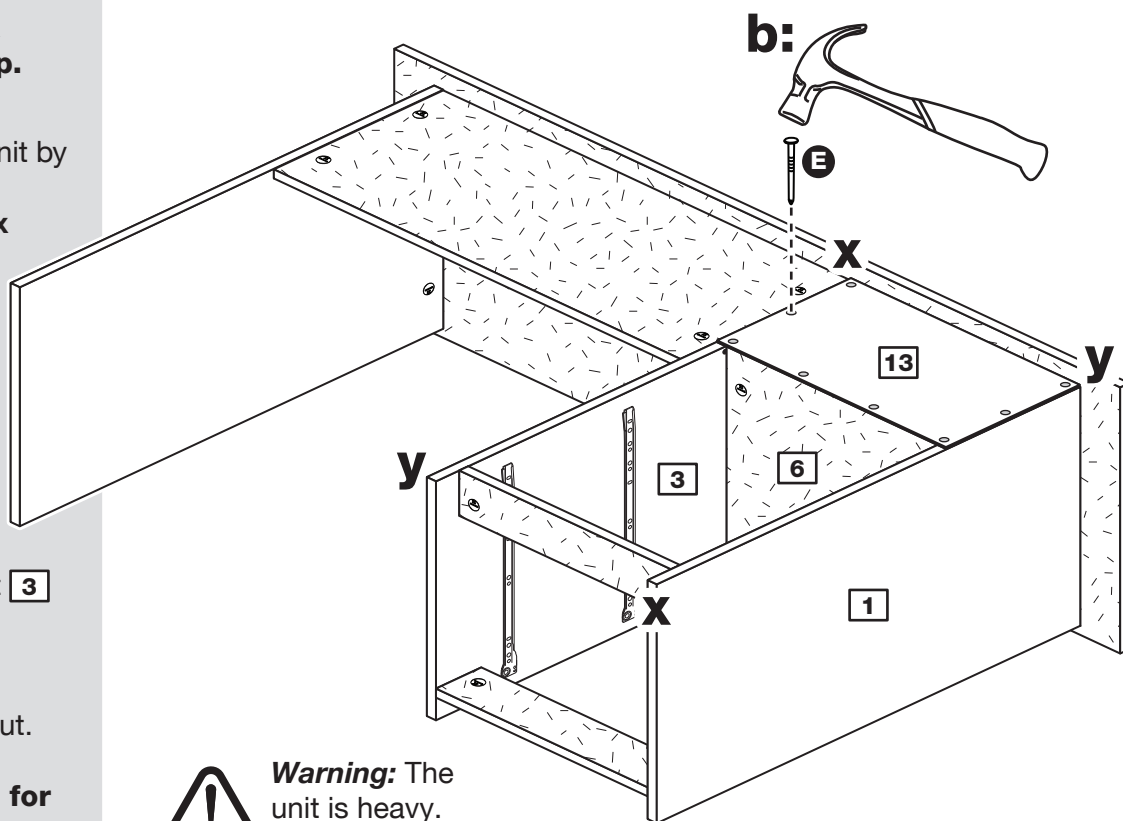

Warning: The unit is heavy. Lift with care.

Assembly Instructions

Step 22

Fit the drawers

Slide the wheels of the runners fitted to the drawers, over the wheels of the runners fitted to the side panels and push the drawers into position.

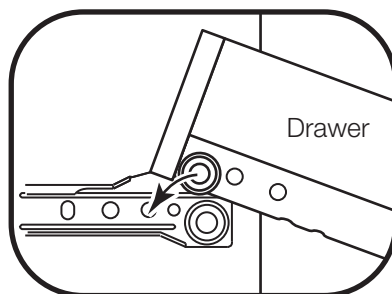
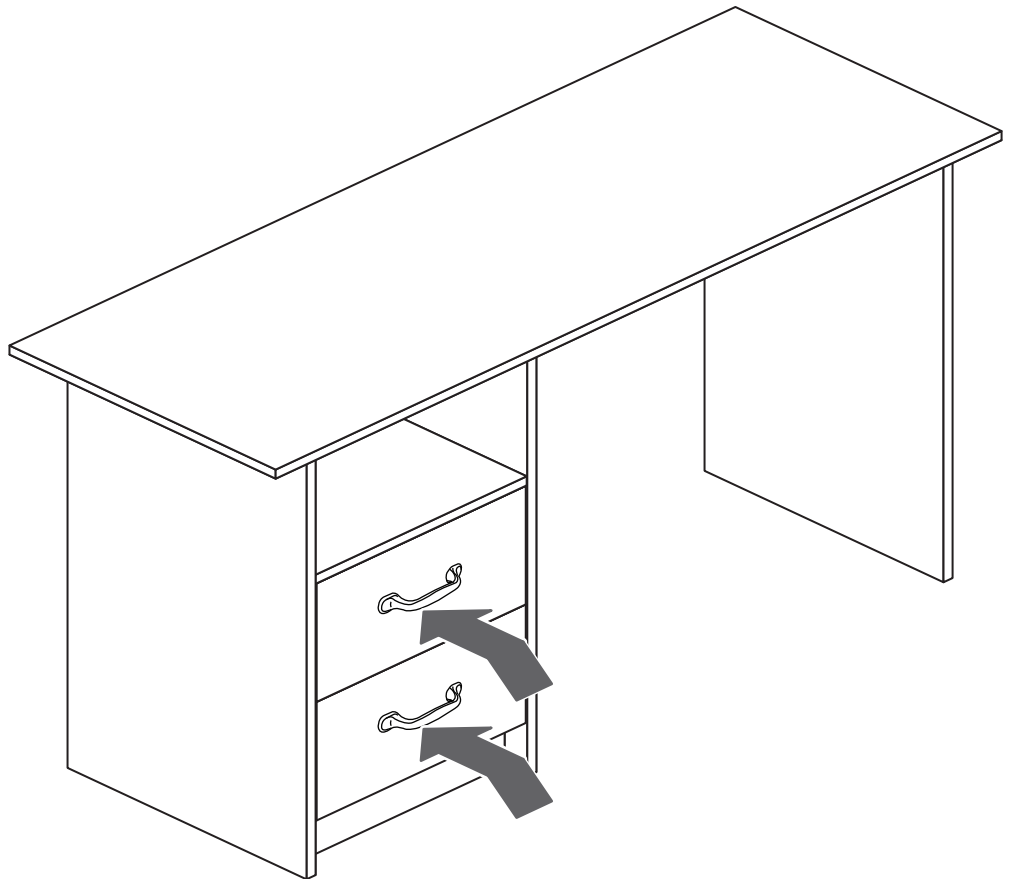

Assembly Instructions

Step 23

Fit the overbalance protector kit

To prevent possible overbalancing we recommend that this unit is secured to a suitable wall by fitting of the overbalance protector kit **1** to the unit, or an alternative fixing method of your choice.

Wall fixings are not supplied as they will need to suit the wall type.

Note: Take care when drilling the wall that you do not drill into any pipes, wires etc. If in doubt, consult an expert.

Assembly is complete



Warning: The unit is heavy. Lift with care.

Example

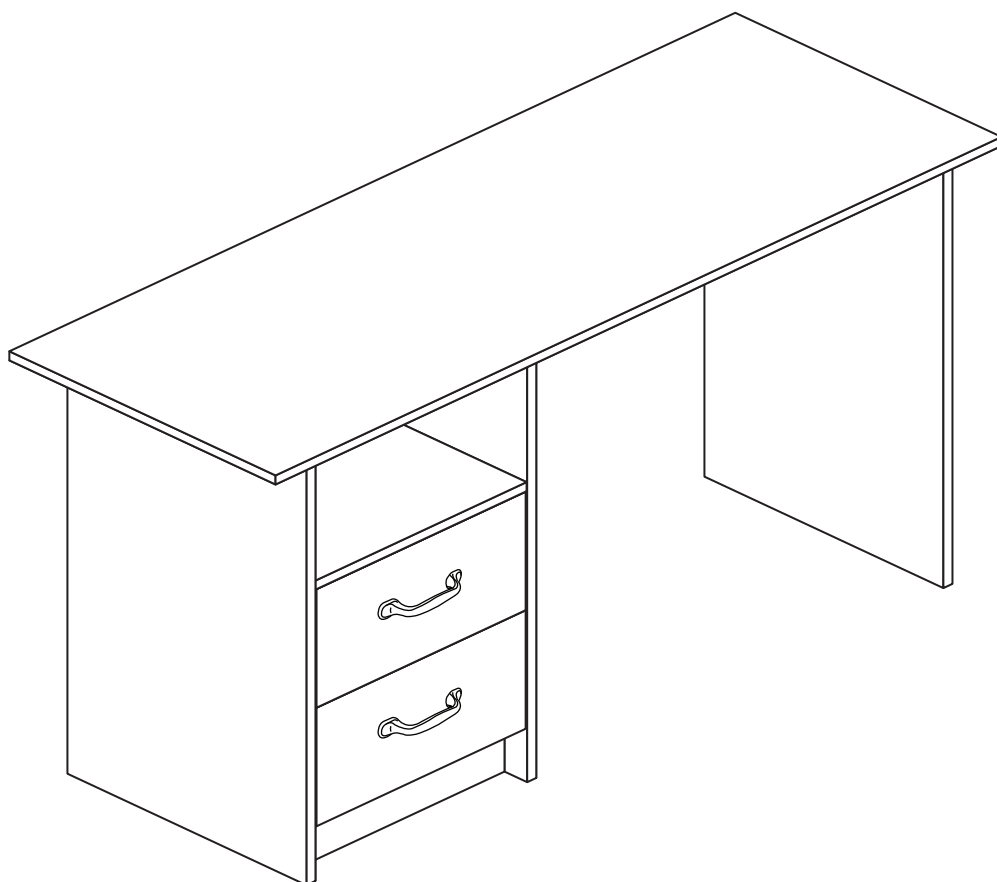
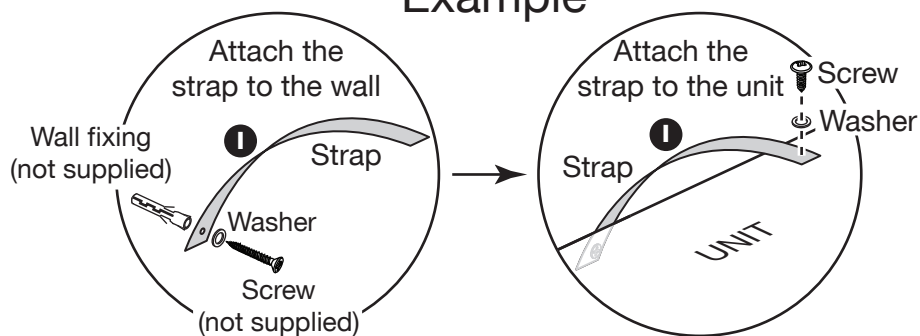

If you need help or have damaged or missing parts, call the **Customer Helpline: 08456 400800** and quote the reference numbers on the component pages.

Argos Ltd, 489-499 Avebury Boulevard, Central Milton Keynes, MK9 2NW

