

Cheval - Bedside

Assembly Instructions - Please keep for future reference

147/3100

152/8794

152/7939

146/1480

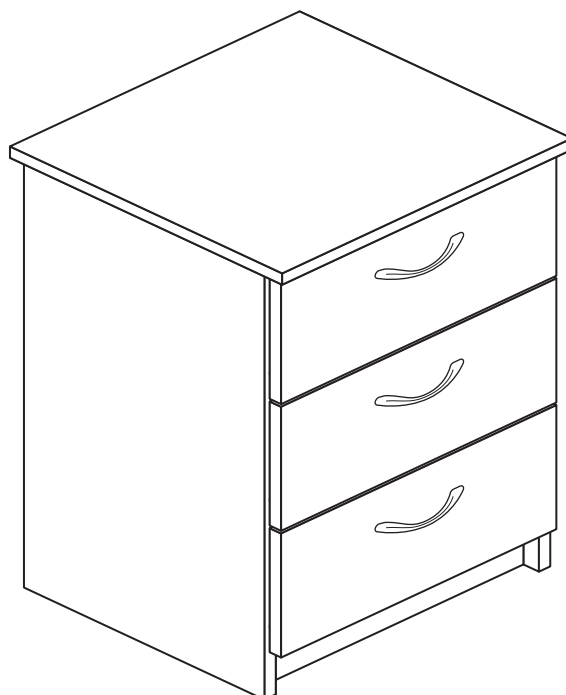

Dimensions

Width - 38.5cm

Depth - 36cm

Height - 58cm



**MADE IN
BRITAIN**

Important - Please read these instructions fully before starting assembly

If you need help or have damaged or missing parts, call the **Customer Helpline: 08456 400800**



Safety and Care Advice

Important - Please read these instructions fully before starting assembly

- **Warning:** This unit weighs approximately 12kgs. Please lift with care.

- Check you have all the components and tools listed on pages 2 and 3.

- Remove all fittings from the plastic bags and separate them into their groups.

- Keep children and animals away from the work area, small parts could choke if swallowed.

- Parts of the assembly will be easier with 2 people.

- Make sure you have enough space to layout the parts before starting.

- Do not stand or put weight on the product, this could cause damage.

- Assemble the item as close to its final position (in the same room) as possible.

- Assemble on a soft level surface to avoid damaging the unit or your floor (use opened out unit carton).



- We do not recommend the use of power drill/drivers **for inserting screws**, as this could damage the unit. Only use hand screwdrivers.

- **Safety note:** If there is any chance of this unit being pulled over by children etc. it is recommended that the unit is secured to a wall using suitable fixings (not supplied).

- Dispose of all packaging carefully and responsibly.

Care and maintenance

- Only clean using a damp cloth and mild detergent, do not use bleach or abrasive cleaners.

- From time to time check that there are no loose screws on this unit.

- This product should not be discarded with household waste. Take to your local authority waste disposal centre.

Note: If required the next page can be cut out and used as reference throughout the assembly. Keep this page with these instructions for future reference.

Components - Panels

If you have damaged or missing components, call the
Customer Helpline: 08456 400800 quoting the reference
numbers below

Please check you have all the panels listed below

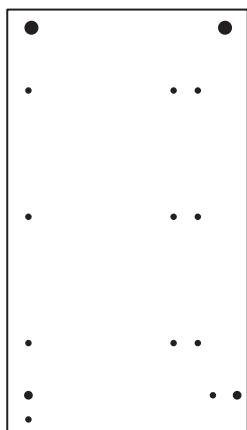

1 Left Side (D2736A)
(562 x 318mm)

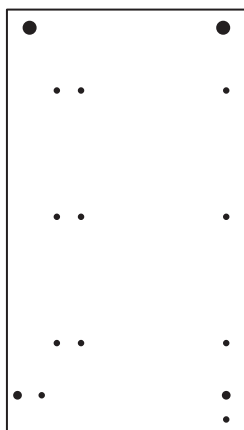

2 Right Side (D2735A)
(562 x 318mm)

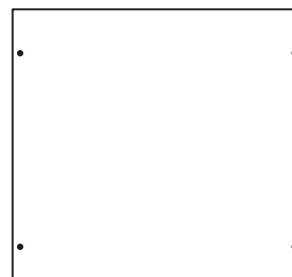

3 Top (D2734A)
(383 x 360mm)

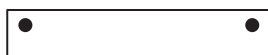

4 Rail (D2737A)
(348 x 66mm) x 2

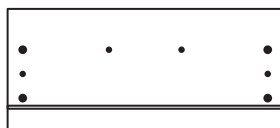

5 Drawer Front (D2738A)
(364 x 164mm) x 3



6 Drawer Back (W311-124)
(311 x 124mm) x 3

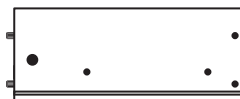

7 Left Drawer Side (W300-124LH)
(300 x 124mm) x 3

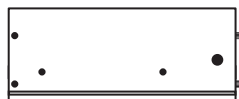

8 Right Drawer Side (W300-124RH)
(300 x 124mm) x 3

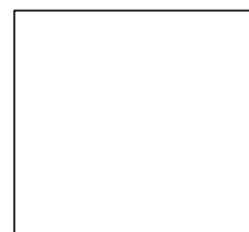

9 Drawer Base (T322-297)
(322 x 297mm) x 3

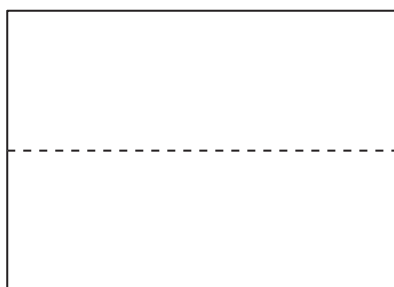

10 Back (X515-370)
(515 x 370mm)











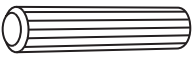
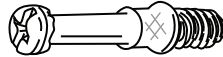
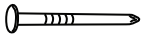

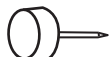
Components - Fittings

If you have damaged or missing components, call the **Customer Helpline: 08456 400800** quoting the reference numbers below

Please check you have all the fittings listed below

Note: The quantities below are the correct amount to complete the assembly. In some cases more fittings may be supplied than are required.

<p>A </p> <p>Wooden dowel (F22) x 4</p>	<p>B </p> <p>Metal dowel (F901) x 14</p>	<p>C </p> <p>Nail (F51) x 12</p>
<p>D </p> <p>Large locking nut (F900) x 8</p>	<p>E </p> <p>Small locking nut (F3) x 6</p>	<p>F </p> <p>Plastic Nail (F91) x 4</p>
<p>G </p> <p>19mm Screw (F461) x 6</p>	<p>H </p> <p>9mm Screw (F74) x 6</p>	<p>I </p> <p>9mm Screw (F73) x 12</p>
<p>J </p> <p>Drawer runner (F1004) x 6</p>		<p>K </p> <p>Knock-in Peg (F171) x 12</p>
<p>L </p> <p>Handle (F273) x 3</p>	<p>M </p> <p>Wedgefix (F639) x 6</p>	

Tools required

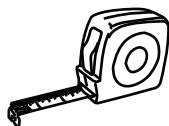

Rule



Cross-head screwdriver



Scissors



Hammer



Eye protection
(when using a hammer or drill)

Ruler - Use this ruler to help correctly identify the screws

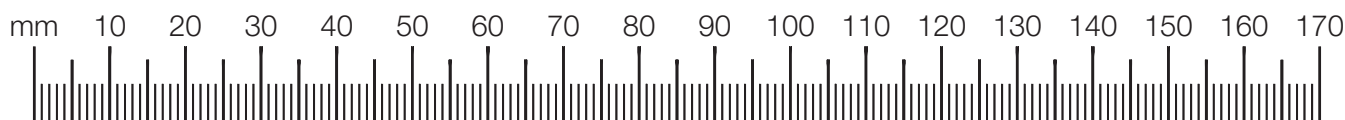

Assembly Instructions

If you have damaged or missing components, call the Customer Helpline: 08456 400800 quoting the reference numbers below

Step 1

Prepare the 3 drawer fronts

Screw 2 metal dowels **B** into each of the 3 drawer fronts **5**.

Note: Tighten the metal dowels up fully against the panels.

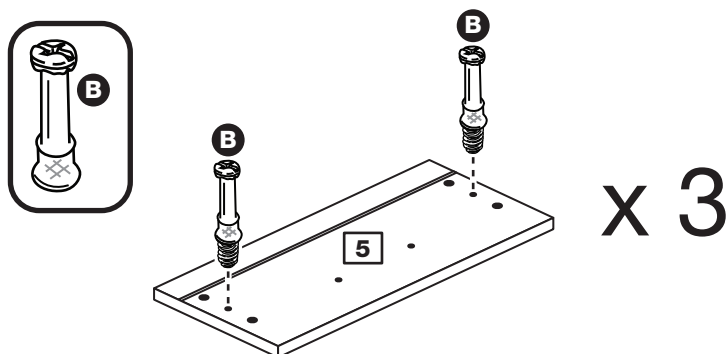

Step 2

Prepare the drawer sides

Insert a small locking nut **E** into the hole shown on the left drawer side **7** and the right drawer side **8**.

Note: The arrow on the locking nut **must** point towards the hole in the edge of the panel.

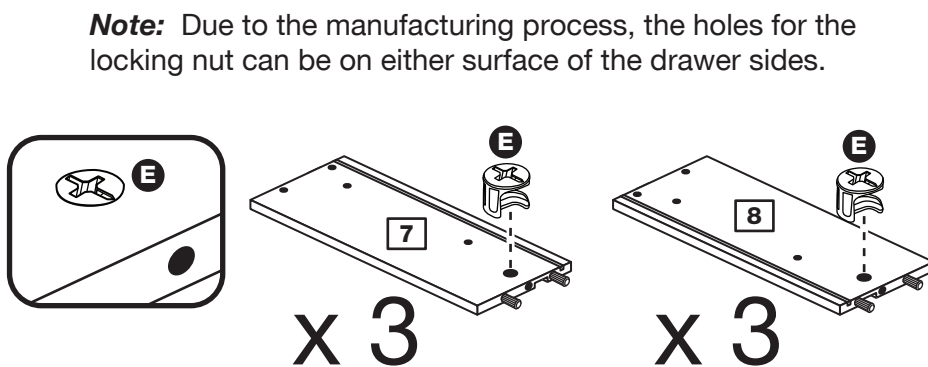

Step 3

Attach the drawer sides to the drawer front

Push the left drawer side **7** and right drawer side **8** onto the back of the drawer front **5**.

Turn the small locking nuts **E** on the left drawer side **7** and right drawer side **8**.

Note: Turn the locking nuts **E** clockwise to secure panels - more than 1/2 a turn.

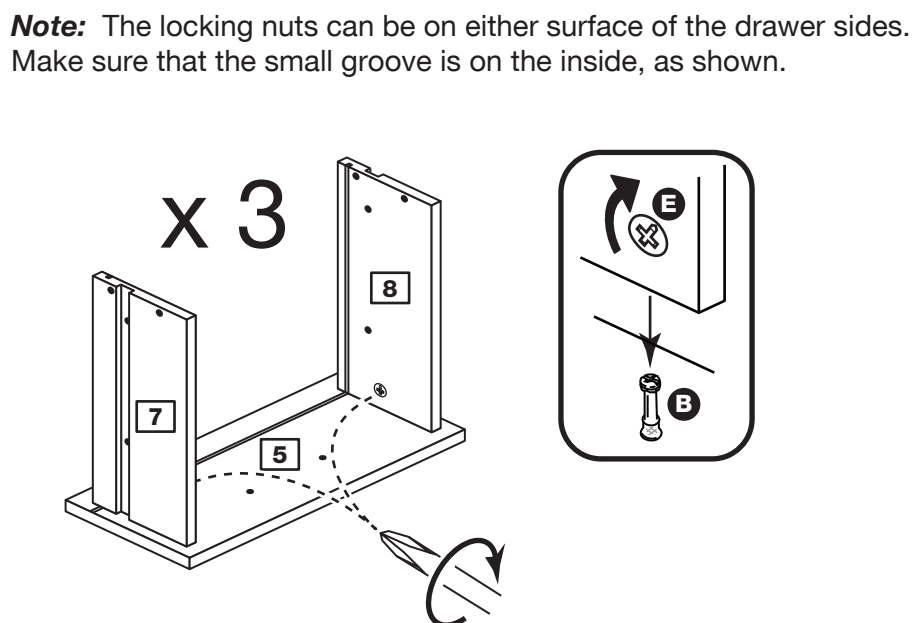

Assembly Instructions

Step 4

Fit the drawer base

Slide the drawer base **9** down the grooves in the drawer sides **7** and **8** and down into the groove in the drawer front **5**.

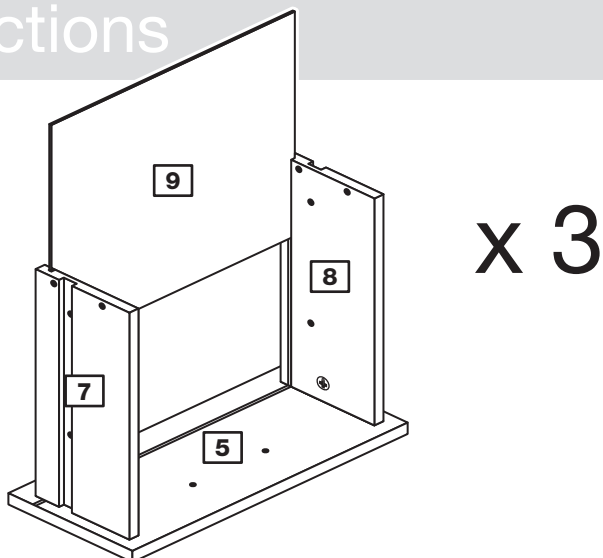

Step 5

Fit the drawer back

Fit the drawer back **6** between the drawer sides **7** and **8**.

Make sure that the drawer base **9** fits into the groove in the drawer back **6**.

Hold the drawer back **6** in position and tap the knock-in pegs **K** through the holes in the drawer sides **7** and **8**.

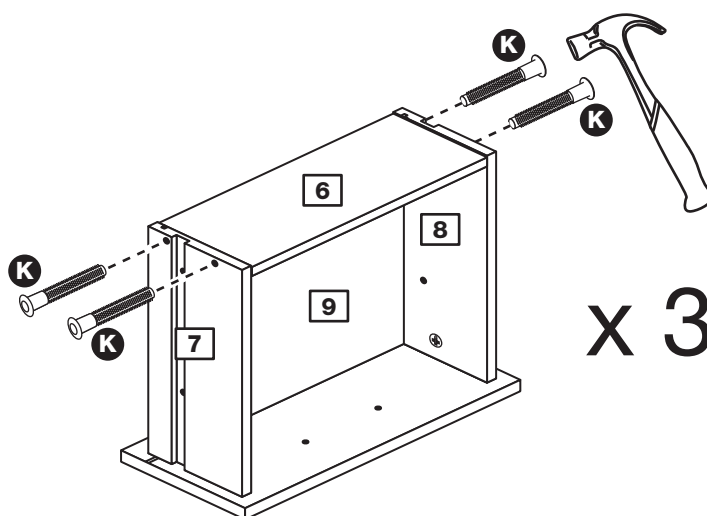

Step 6

Attach the handle

Attach a handle **L** to each drawer front **5** using 2 screws **G**.

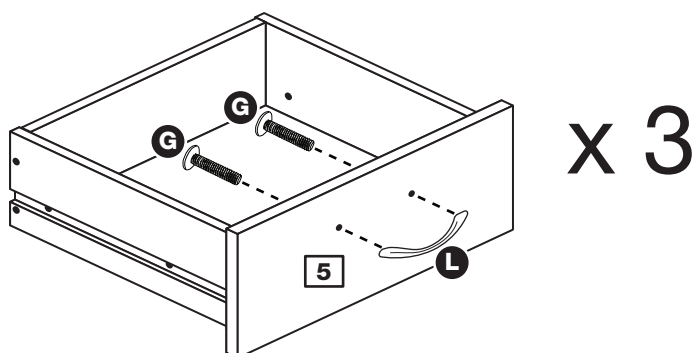

Step 7

Fit the wedgexes

Turn the drawer assemblies over and slide 2 wedgexes **M** into the front and back grooves, as shown, and tighten up the screws.

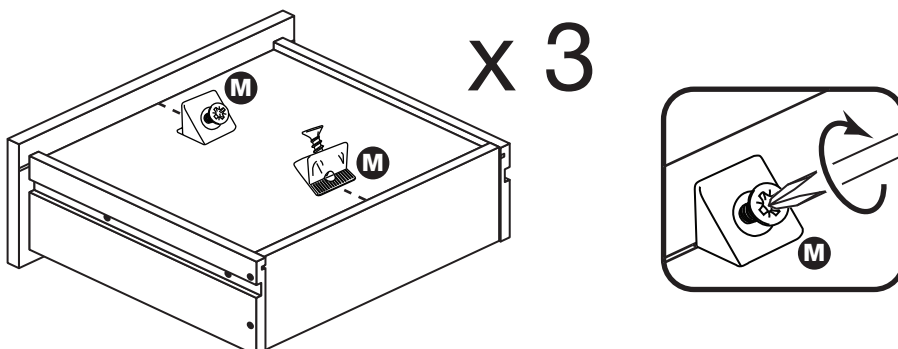

Assembly Instructions

Step 8

Prepare the left side

a: Place 3 runners **J** on the left side **1** as shown. Slide back the top of runner and use the 2nd hole from the front to fit the 1st screw **I**.

b: Slide the runner **J** back the other way and fit the 2nd screw **I** into the corresponding hole in the left side **1**.

c: Screw 2 metal dowels **B** into the left side **1**.

Insert 2 large locking nuts **D** into the left side **1**.

Note: The arrow on the locking nuts **must** point towards the hole in the edge of the panel.

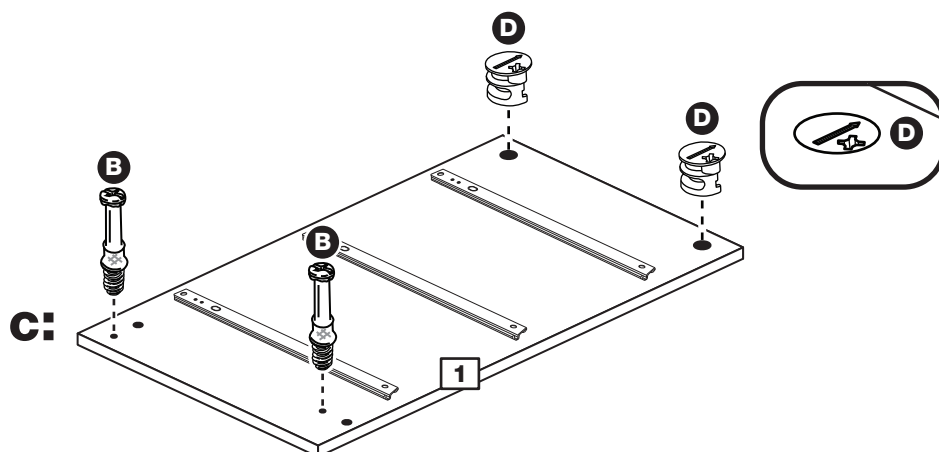
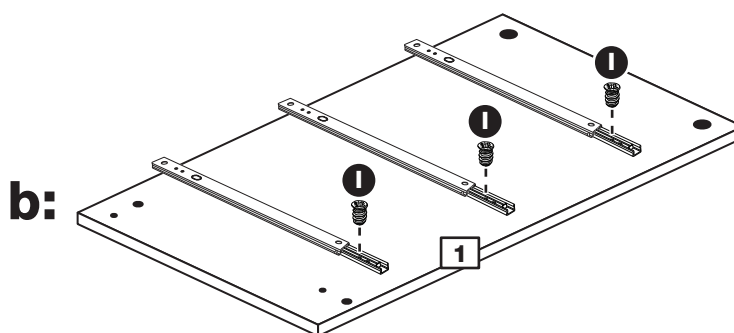
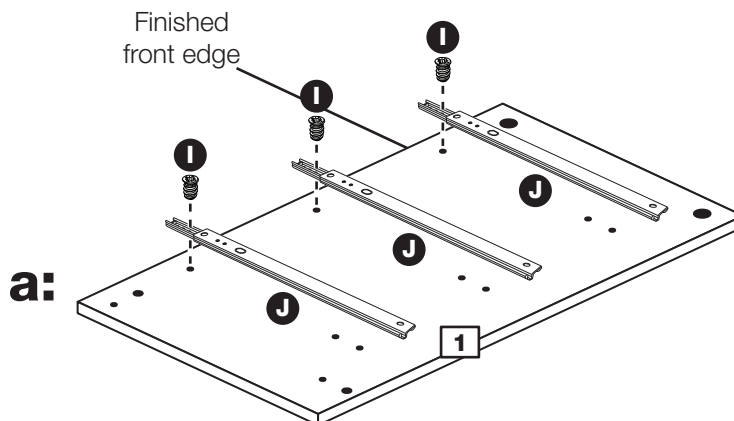
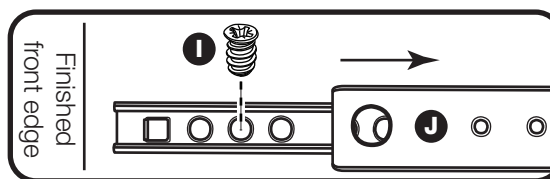

Assembly Instructions

Step 9

Prepare the right side

a: Place 3 runners **J** on the right side **2** as shown. Slide back the top of runner and use the 2nd hole from the front to fit the 1st screw **I**.

b: Slide the runner **J** back the other way and fit the 2nd screw **I** into the corresponding hole in the right side **2**.

c: Screw 2 metal dowels **B** into the right side **2**.

Insert 2 large locking nuts **D** into the right side **2**.

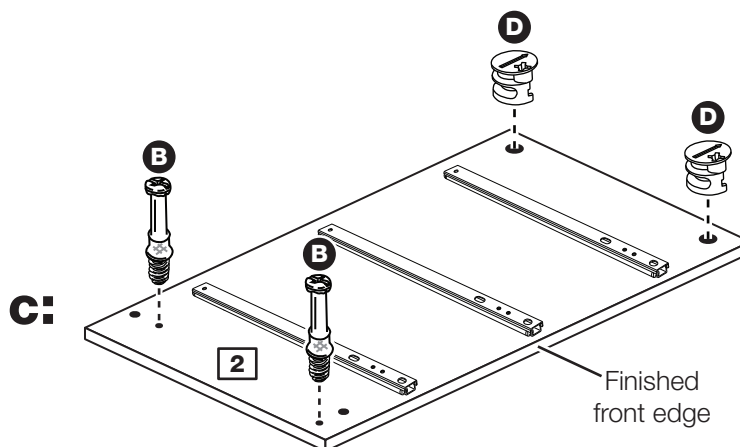
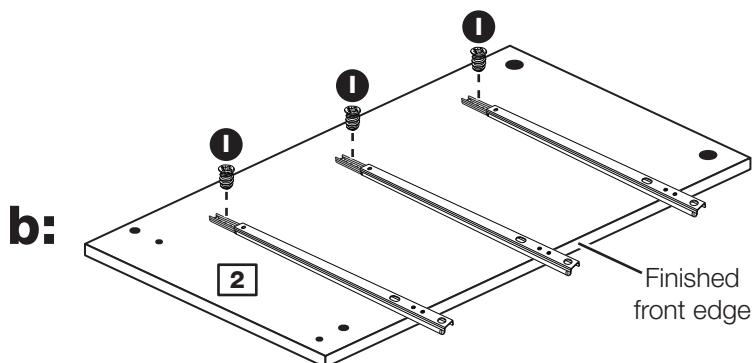
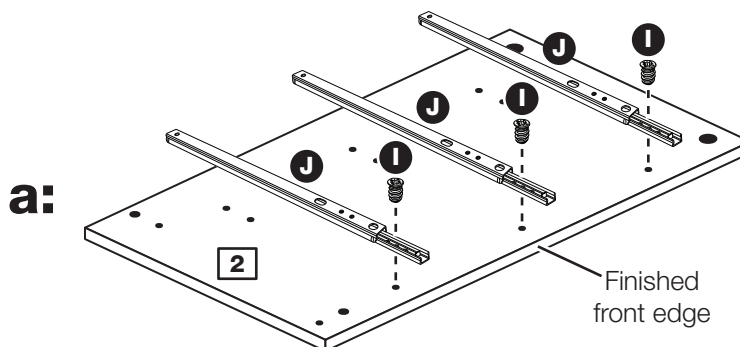
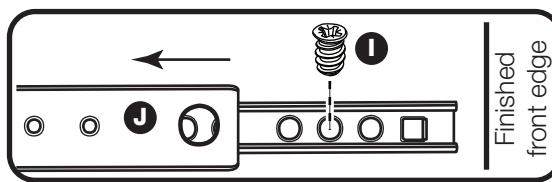

Assembly Instructions

Step 10

Prepare the 2 rails

Tap 2 wooden dowels **A** into each rail **4**.

Note: Wooden dowels **must not** stick out from the edge by more than 10mm or they may damage other panels.

Insert 2 large locking nuts **D** into each rail **4**.

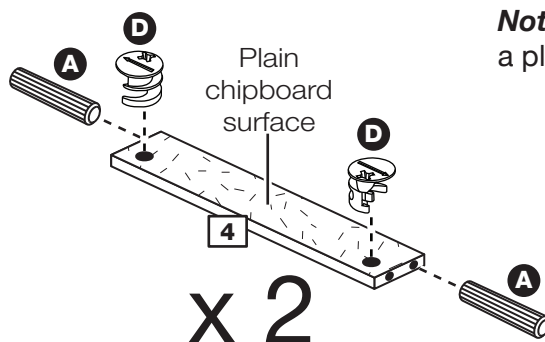

Note: The 2 rails can have a plain chipboard surface.

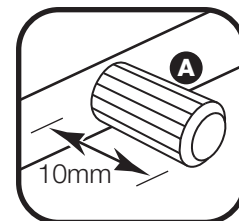

Step 11

Fit the 2 rails

Push the 2 rails **4** onto the right side **2**.

Use a screwdriver to tighten the large locking nut **D** fitted to each rail **4**.

Note: Turn the large locking nuts **D** as far as they will go - more than 1/2 a turn.

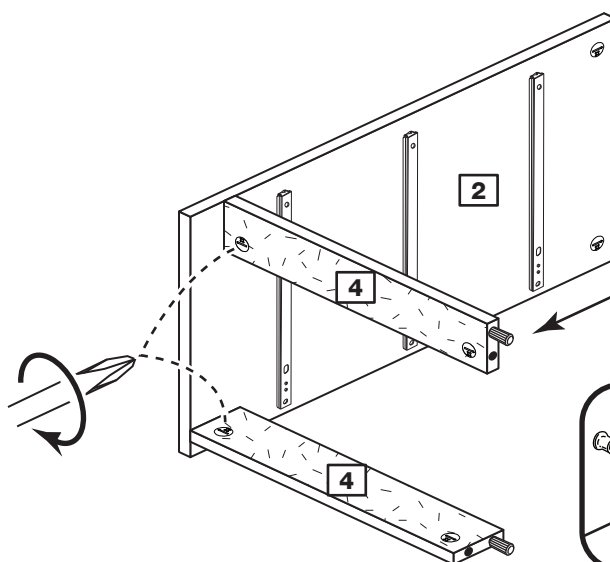

Note: Support this rail until the left side has been fitted in the next step.

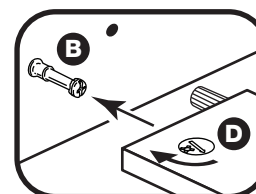

Step 12

Fit the left side

Push the left side **1** onto the 2 rails **4**.

Use a screwdriver to tighten the large locking nut **D** fitted to each rail **4**.

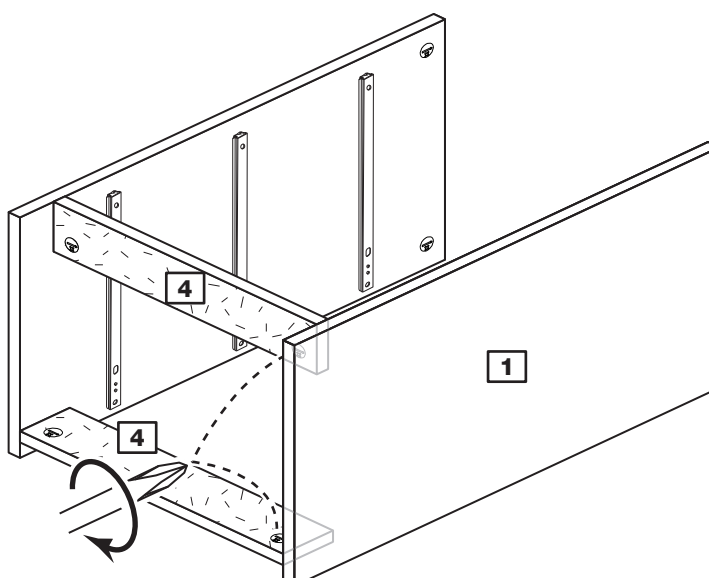

Assembly Instructions

Step 13

Prepare the top

Screw 4 metal dowels **B** into the top **3**.

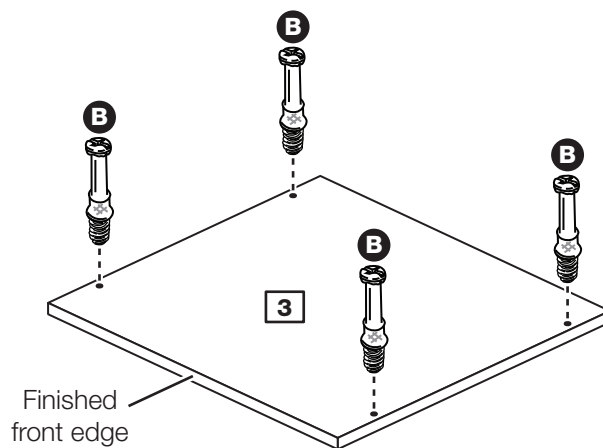

Step 14

Fit the top

Push the top **3** onto the sides **1** and **2**.

Use a screwdriver to tighten the 2 large locking nuts **D** fitted to each side **1** and **2**.

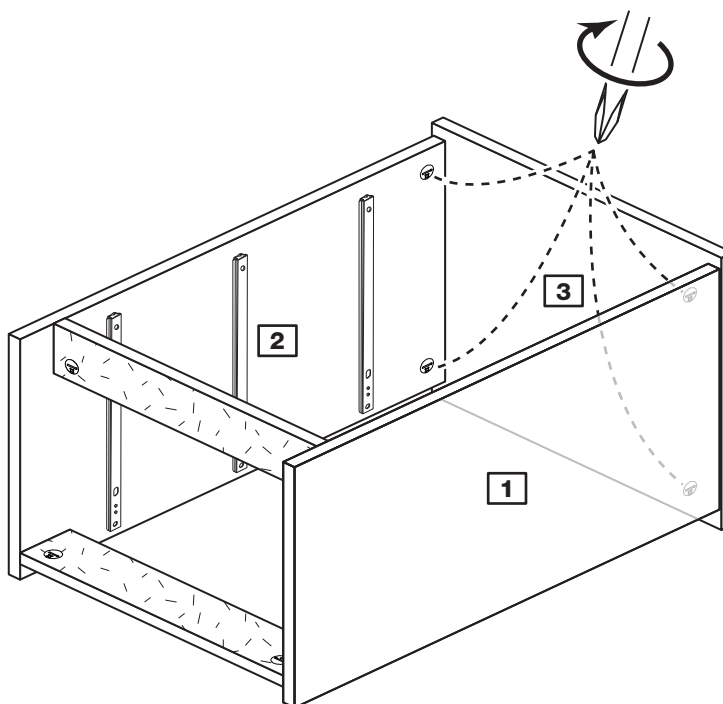

Assembly Instructions

Step 15

Fit the back

a: Square up the unit by making sure that measurement **x** to **x** equals **y** to **y**.

b: Place the back **10** onto the unit, making sure it is pushed up against the top **3**.

Nail **C** along the side edges and the bottom edge of the back **10**.

Note: Nails should be spaced out evenly.

a: The measurement from top corner X to bottom corner X must be equal to the measurement from top corner Y to bottom corner Y

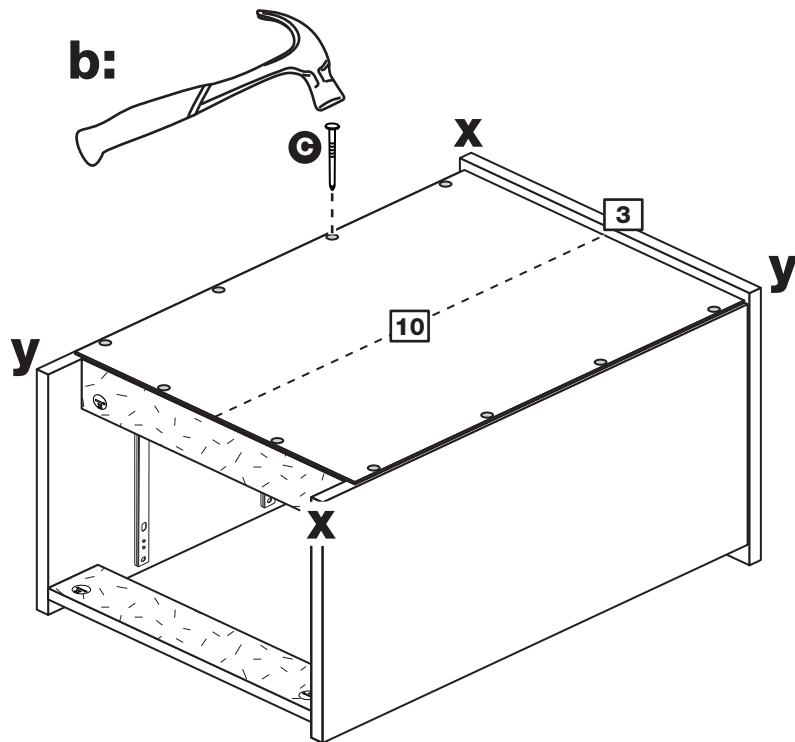

Step 16

Fit the plastic nails

Tap 2 plastic nails **F** into the bottom edge of each of the sides **1** and **2** as shown.

Carefully stand the unit up for the next step.

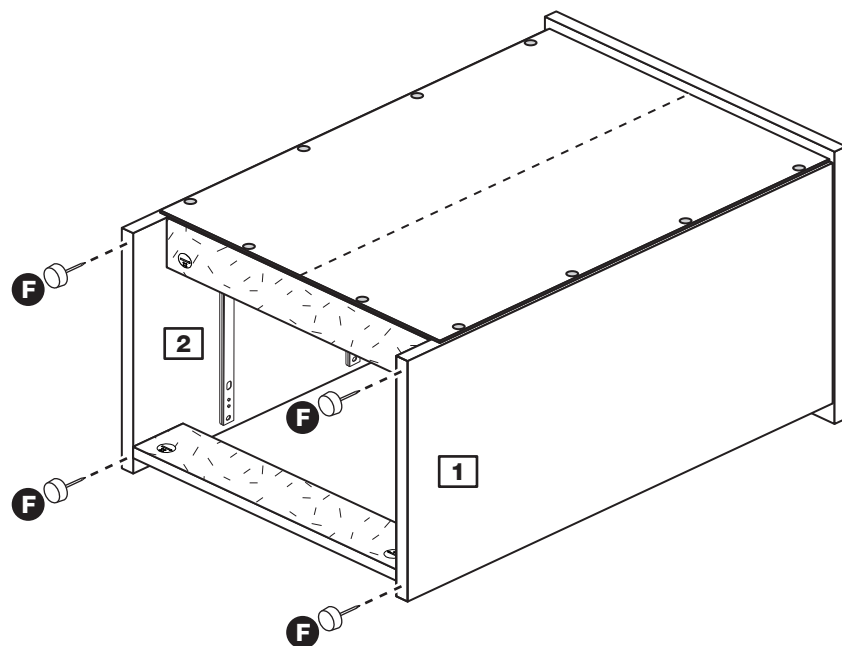

Assembly Instructions

Step 17

Fit the drawers

Starting with the bottom drawer, slide both the runners **J** forward and locate the drawer sides **7** and **8** between them, lining up the holes in the drawer wrap with the 2nd 'threaded' holes in the runners **H**.

Working from the inside of the drawer, insert 2 screws **H** through the drawer sides and out into the 2nd threaded hole in the runner.

Note: Do not overtighten the screws **H**. If they catch on the runner you may need to loosen them slightly.

Assembly is complete

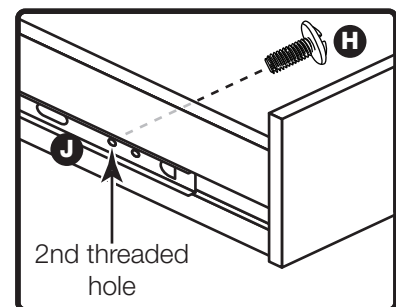
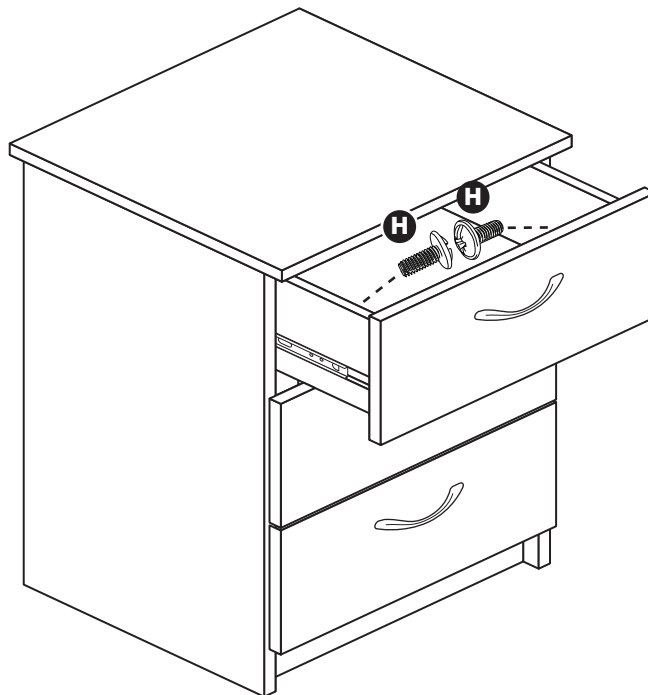

If you need help or have damaged or missing parts, call the Customer Helpline: 08456 400800 and quote the reference numbers on the component pages.

Argos Ltd, 489-499 Avebury Boulevard, Central Milton Keynes, MK9 2NW

Cheval - Bedside

Assembly Instructions - Please keep for future reference

147/3100

152/8794

152/7939

146/1480

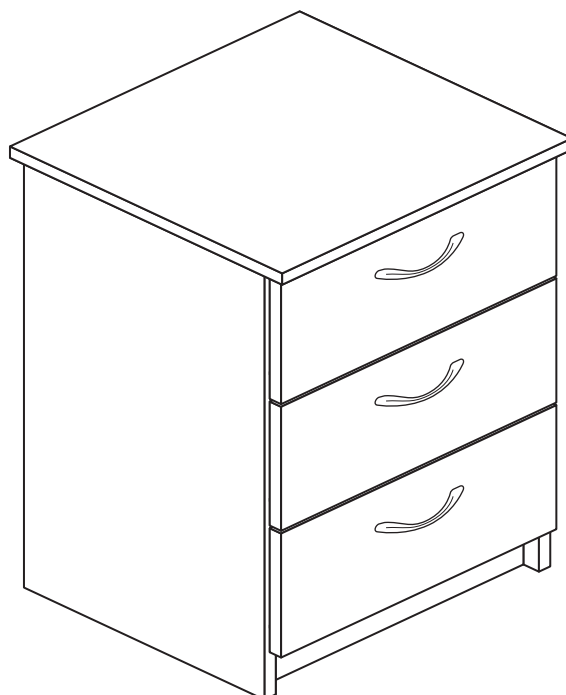

Dimensions

Width - 38.5cm

Depth - 36cm

Height - 58cm



**MADE IN
BRITAIN**

Important - Please read these instructions fully before starting assembly

If you need help or have damaged or missing parts, call the **Customer Helpline: 08456 400800**



Safety and Care Advice

Important - Please read these instructions fully before starting assembly

- **Warning:** This unit weighs approximately 12kgs. Please lift with care.

- Check you have all the components and tools listed on pages 2 and 3.

- Remove all fittings from the plastic bags and separate them into their groups.

- Keep children and animals away from the work area, small parts could choke if swallowed.

- Parts of the assembly will be easier with 2 people.

- Make sure you have enough space to layout the parts before starting.

- Do not stand or put weight on the product, this could cause damage.

- Assemble the item as close to its final position (in the same room) as possible.

- Assemble on a soft level surface to avoid damaging the unit or your floor (use opened out unit carton).



- We do not recommend the use of power drill/drivers **for inserting screws**, as this could damage the unit. Only use hand screwdrivers.

- **Safety note:** If there is any chance of this unit being pulled over by children etc. it is recommended that the unit is secured to a wall using suitable fixings (not supplied).

- Dispose of all packaging carefully and responsibly.

Care and maintenance

- Only clean using a damp cloth and mild detergent, do not use bleach or abrasive cleaners.

- From time to time check that there are no loose screws on this unit.

- This product should not be discarded with household waste. Take to your local authority waste disposal centre.

Note: If required the next page can be cut out and used as reference throughout the assembly. Keep this page with these instructions for future reference.

Components - Panels

If you have damaged or missing components, call the
Customer Helpline: 08456 400800 quoting the reference
numbers below

Please check you have all the panels listed below

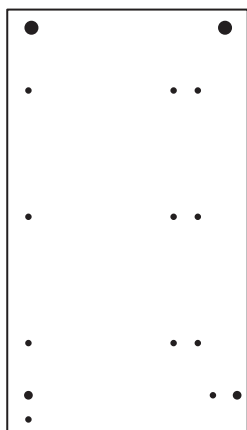

1 Left Side (D2736A)
(562 x 318mm)

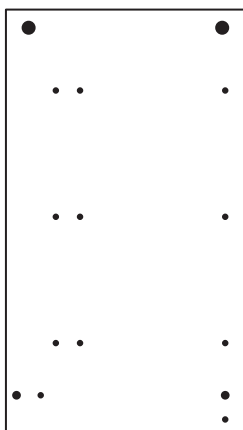

2 Right Side (D2735A)
(562 x 318mm)

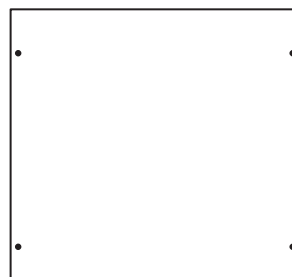

3 Top (D2734A)
(383 x 360mm)

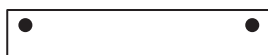

4 Rail (D2737A)
(348 x 66mm) x 2

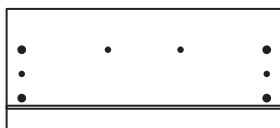

5 Drawer Front (D2738B)
(364 x 164mm) x 3



6 Drawer Back (W314-124)
(314 x 124mm) x 3

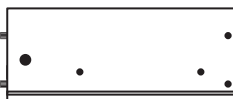

7 Left Drawer Side (W300-124LH)
(300 x 124mm) x 3

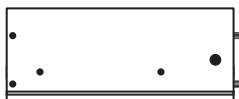

8 Right Drawer Side (W300-124RH)
(300 x 124mm) x 3

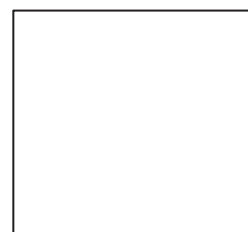

9 Drawer Base (T325-297)
(325 x 297mm) x 3

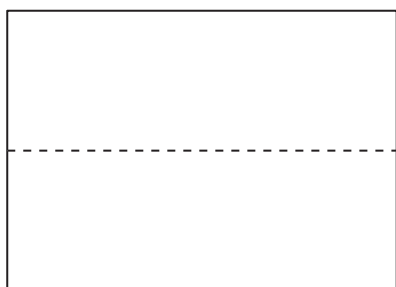

10 Back (X515-370)
(515 x 370mm)











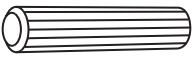
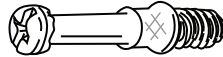
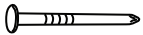

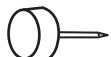
Components - Fittings

If you have damaged or missing components, call the **Customer Helpline: 08456 400800** quoting the reference numbers below

Please check you have all the fittings listed below

Note: The quantities below are the correct amount to complete the assembly. In some cases more fittings may be supplied than are required.

<p>A </p> <p>Wooden dowel (F22) x 4</p>	<p>B </p> <p>Metal dowel (F901) x 14</p>	<p>C </p> <p>Nail (F51) x 12</p>
<p>D </p> <p>Large locking nut (F900) x 8</p>	<p>E </p> <p>Small locking nut (F3) x 6</p>	<p>F </p> <p>Plastic Nail (F91) x 4</p>
<p>G </p> <p>19mm Screw (F461) x 6</p>	<p>H </p> <p>9mm Screw (F74) x 6</p>	<p>I </p> <p>9mm Screw (F73) x 12</p>
<p>J </p> <p>Drawer runner (F1004) x 6</p>		<p>K </p> <p>Knock-in Peg (F171) x 12</p>
<p>L </p> <p>Handle (F273) x 3</p>	<p>M </p> <p>Wedgefix (F639) x 6</p>	

Tools required

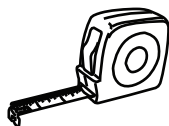

Rule



Cross-head screwdriver



Scissors



Hammer



Eye protection
(when using a hammer or drill)

Ruler - Use this ruler to help correctly identify the screws

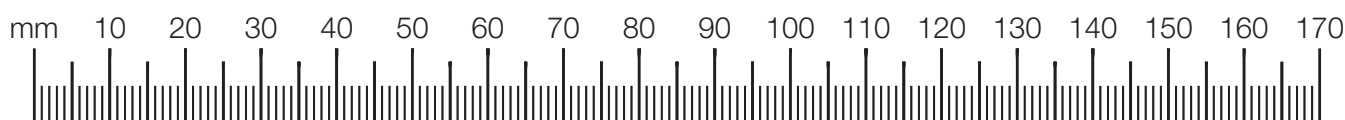

Assembly Instructions

If you have damaged or missing components, call the Customer Helpline: 08456 400800 quoting the reference numbers below

Step 1

Prepare the 3 drawer fronts

Screw 2 metal dowels **B** into each of the 3 drawer fronts **5**.

Note: Tighten the metal dowels up fully against the panels.

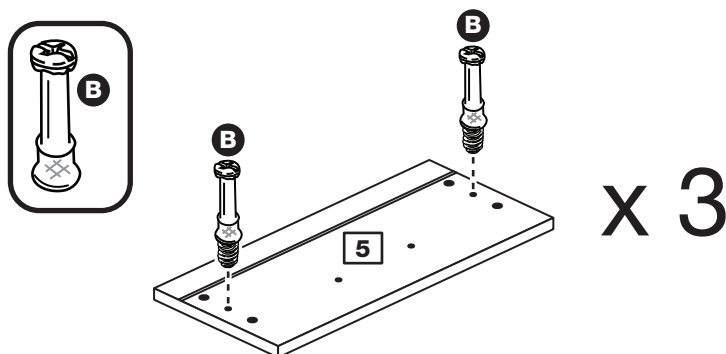

Step 2

Prepare the drawer sides

Insert a small locking nut **E** into the hole shown on the left drawer side **7** and the right drawer side **8**.

Note: The arrow on the locking nut **must** point towards the hole in the edge of the panel.

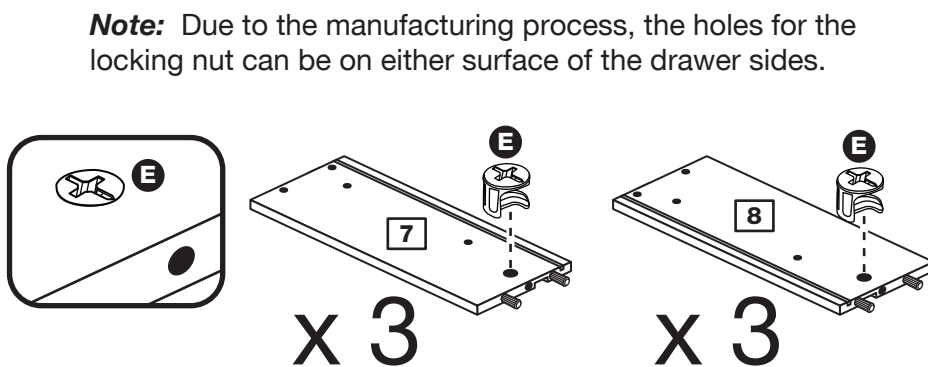

Step 3

Attach the drawer sides to the drawer front

Push the left drawer side **7** and right drawer side **8** onto the back of the drawer front **5**.

Turn the small locking nuts **E** on the left drawer side **7** and right drawer side **8**.

Note: Turn the locking nuts **E** clockwise to secure panels - more than 1/2 a turn.

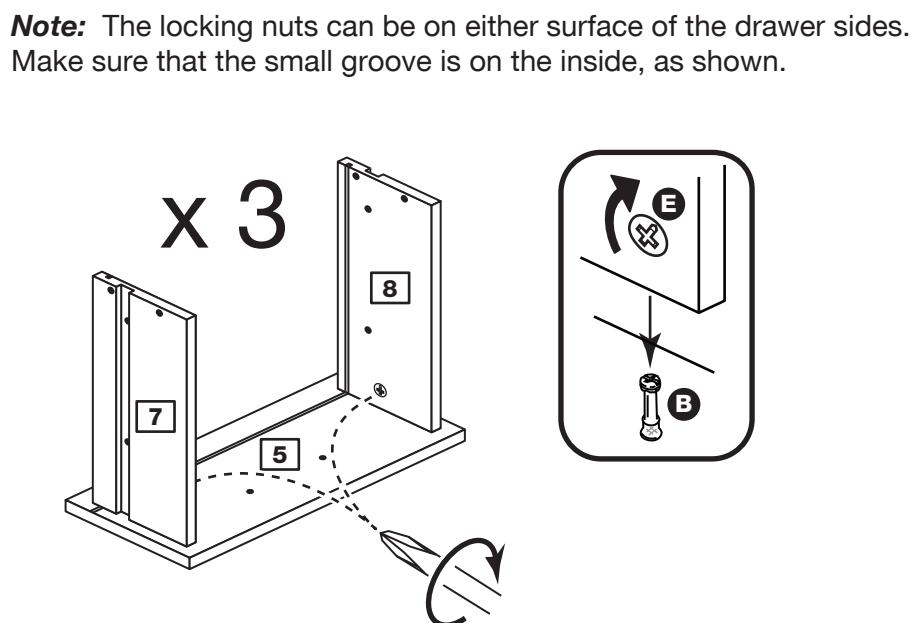

Assembly Instructions

Step 4

Fit the drawer base

Slide the drawer base **9** down the grooves in the drawer sides **7** and **8** and down into the groove in the drawer front **5**.

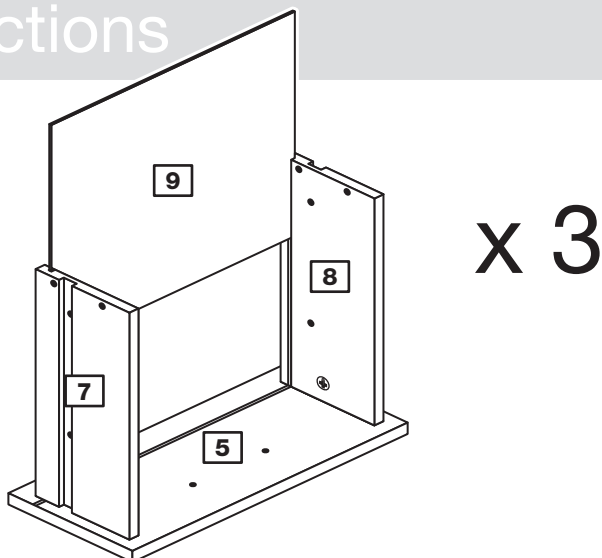

Step 5

Fit the drawer back

Fit the drawer back **6** between the drawer sides **7** and **8**.

Make sure that the drawer base **9** fits into the groove in the drawer back **6**.

Hold the drawer back **6** in position and tap the knock-in pegs **K** through the holes in the drawer sides **7** and **8**.

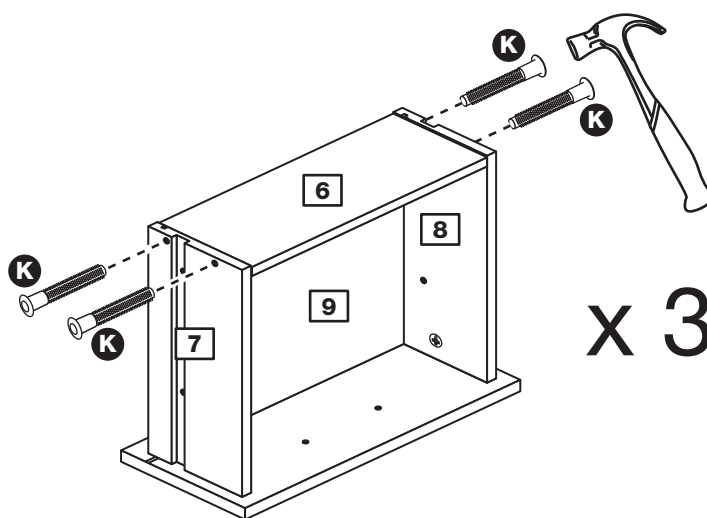

Step 6

Attach the handle

Attach a handle **L** to each drawer front **5** using 2 screws **G**.

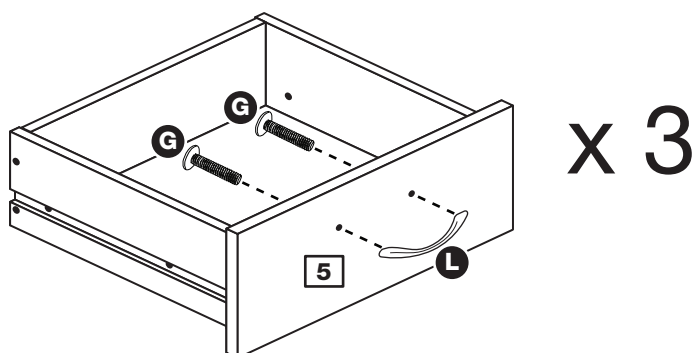

Step 7

Fit the wedgifixes

Turn the drawer assemblies over and slide 2 wedgifixes **M** into the front and back grooves, as shown, and tighten up the screws.

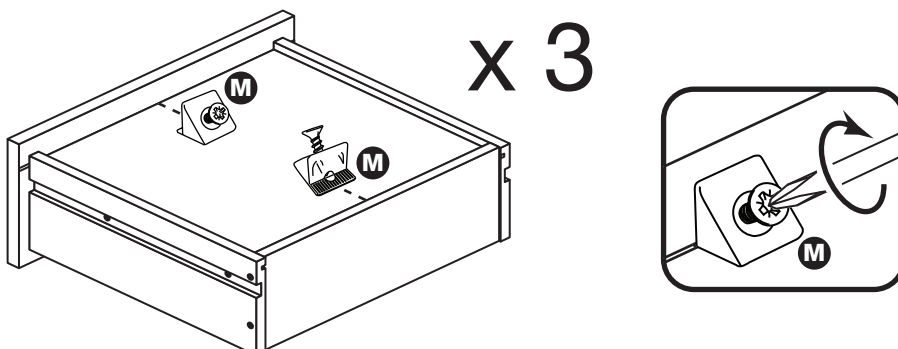

Assembly Instructions

Step 8

Prepare the left side

a: Place 3 runners **J** on the left side **1** as shown. Slide back the top of runner and use the 2nd hole from the front to fit the 1st screw **I**.

b: Slide the runner **J** back the other way and fit the 2nd screw **I** into the corresponding hole in the left side **1**.

c: Screw 2 metal dowels **B** into the left side **1**.

Insert 2 large locking nuts **D** into the left side **1**.

Note: The arrow on the locking nuts **must** point towards the hole in the edge of the panel.

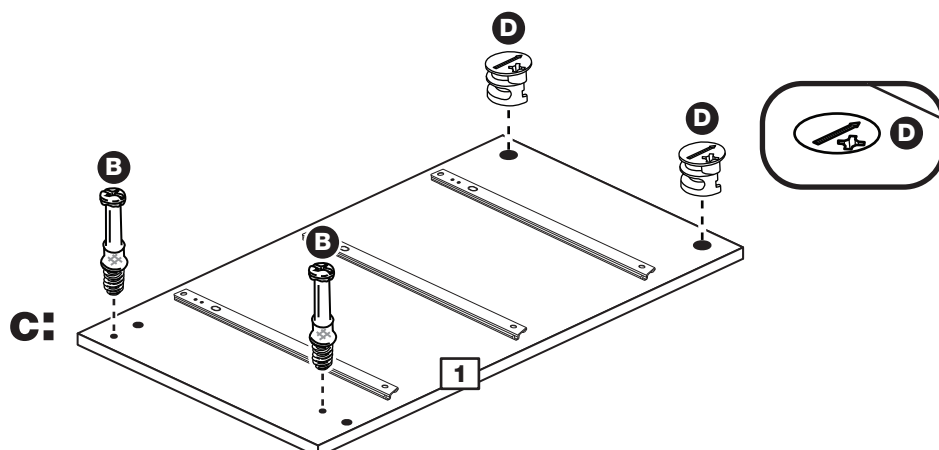
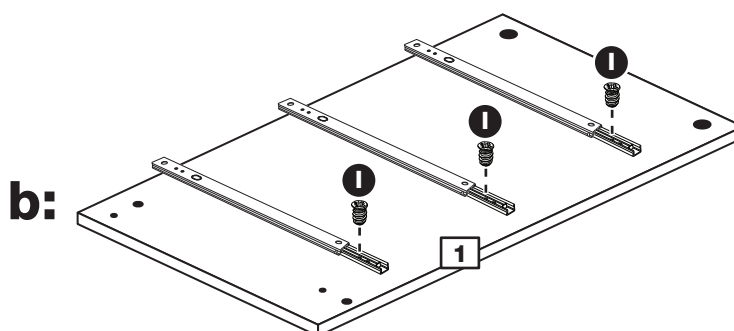
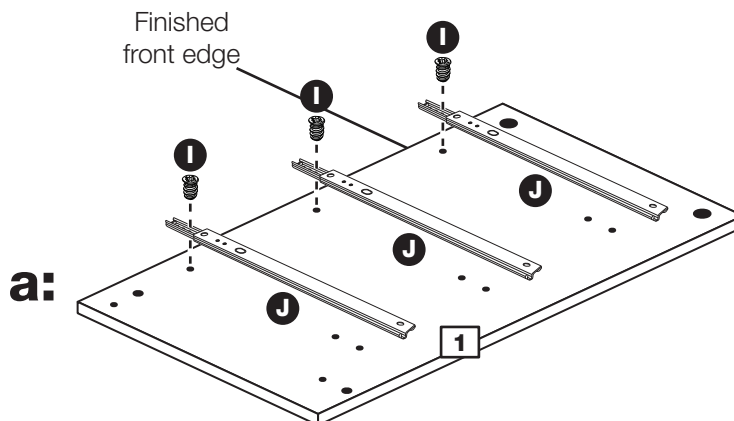
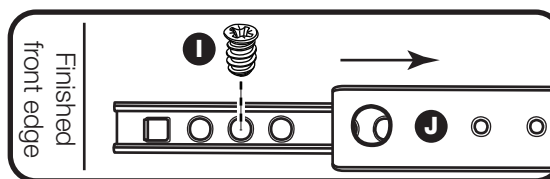

Assembly Instructions

Step 9

Prepare the right side

a: Place 3 runners **J** on the right side **2** as shown. Slide back the top of runner and use the 2nd hole from the front to fit the 1st screw **I**.

b: Slide the runner **J** back the other way and fit the 2nd screw **I** into the corresponding hole in the right side **2**.

c: Screw 2 metal dowels **B** into the right side **2**.

Insert 2 large locking nuts **D** into the right side **2**.

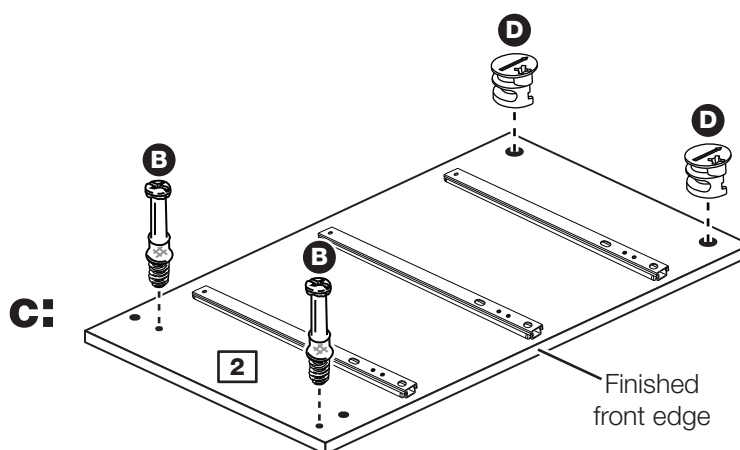
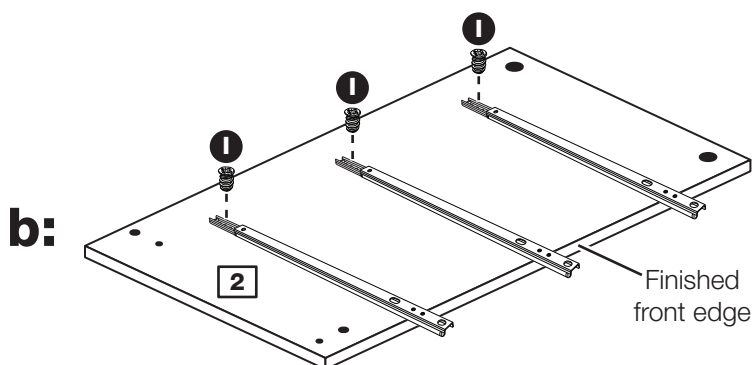
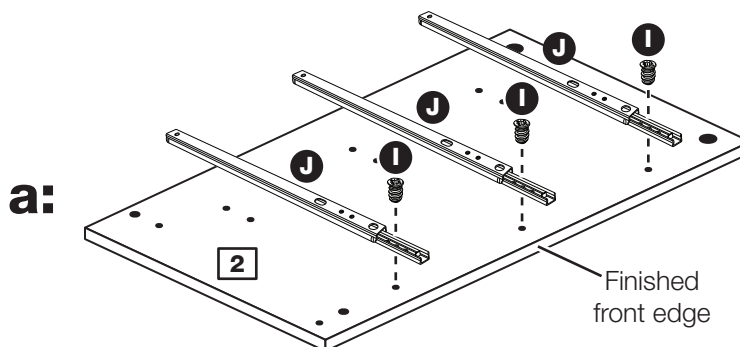
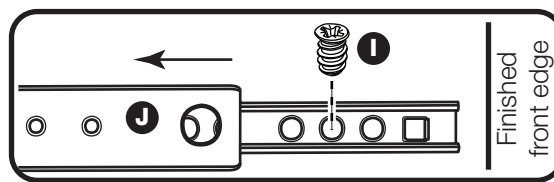

Assembly Instructions

Step 10

Prepare the 2 rails

Tap 2 wooden dowels **A** into each rail **4**.

Note: Wooden dowels **must not** stick out from the edge by more than 10mm or they may damage other panels.

Insert 2 large locking nuts **D** into each rail **4**.

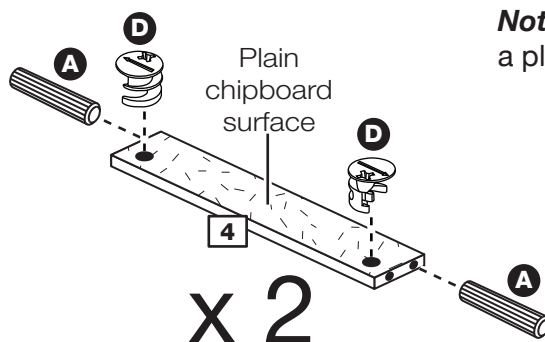

Note: The 2 rails can have a plain chipboard surface.

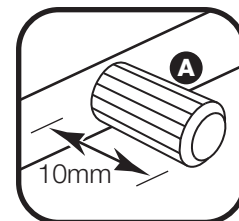

Step 11

Fit the 2 rails

Push the 2 rails **4** onto the right side **2**.

Use a screwdriver to tighten the large locking nut **D** fitted to each rail **4**.

Note: Turn the large locking nuts **D** as far as they will go - more than 1/2 a turn.

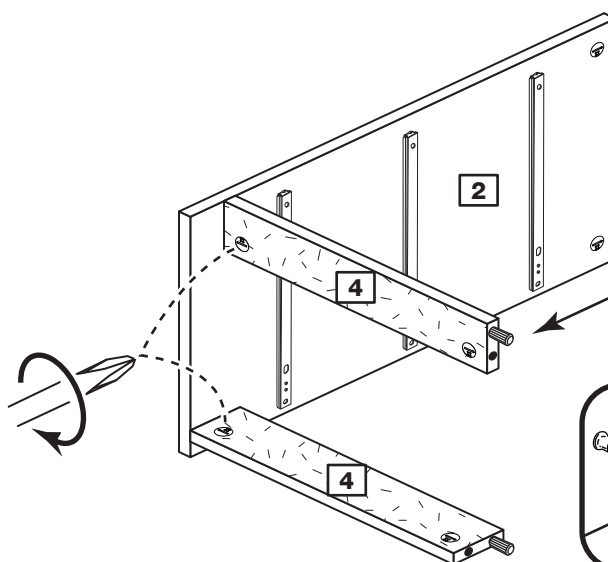

Note: Support this rail until the left side has been fitted in the next step.

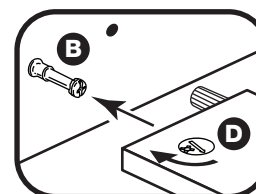

Step 12

Fit the left side

Push the left side **1** onto the 2 rails **4**.

Use a screwdriver to tighten the large locking nut **D** fitted to each rail **4**.

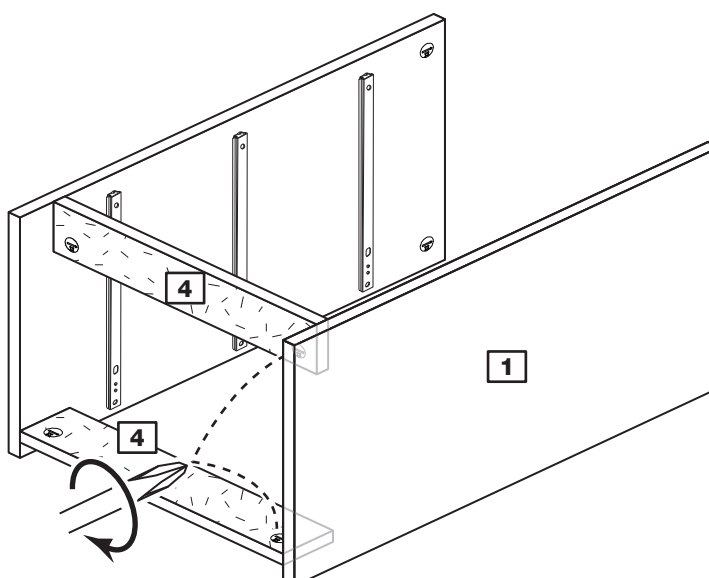

Assembly Instructions

Step 13

Prepare the top

Screw 4 metal dowels **B** into the top **3**.

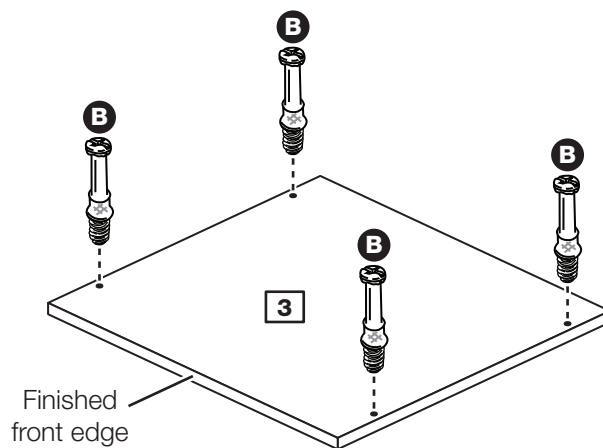

Step 14

Fit the top

Push the top **3** onto the sides **1** and **2**.

Use a screwdriver to tighten the 2 large locking nuts **D** fitted to each side **1** and **2**.

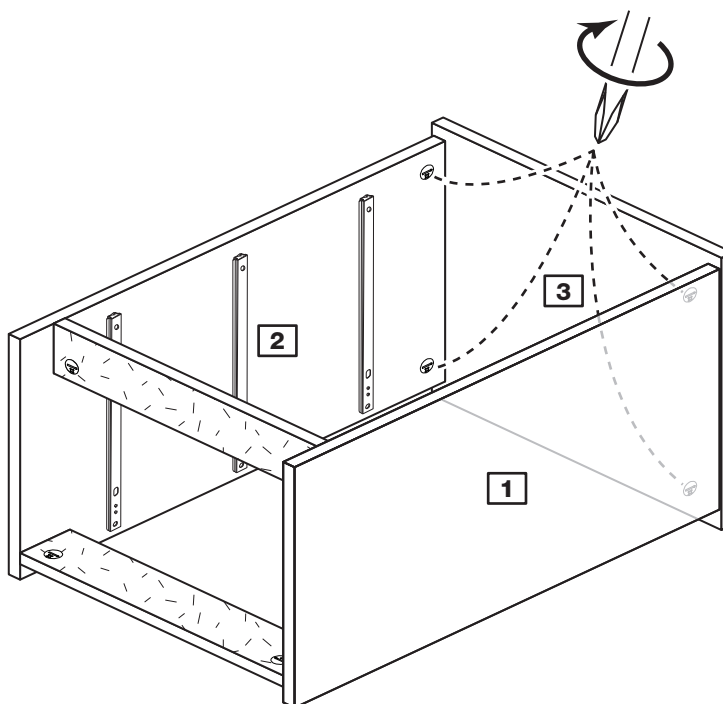

Assembly Instructions

Step 15

Fit the back

a: Square up the unit by making sure that measurement **x** to **x** equals **y** to **y**.

b: Place the back **10** onto the unit, making sure it is pushed up against the top **3**.

Nail **C** along the side edges and the bottom edge of the back **10**.

Note: Nails should be spaced out evenly.

a: The measurement from top corner X to bottom corner X must be equal to the measurement from top corner Y to bottom corner Y

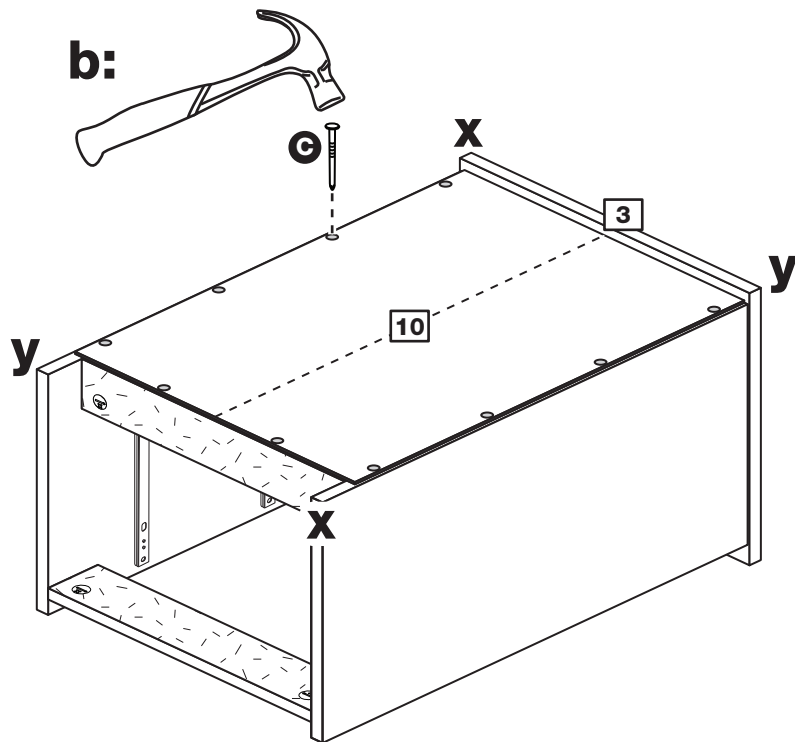

Step 16

Fit the plastic nails

Tap 2 plastic nails **F** into the bottom edge of each of the sides **1** and **2** as shown.

Carefully stand the unit up for the next step.

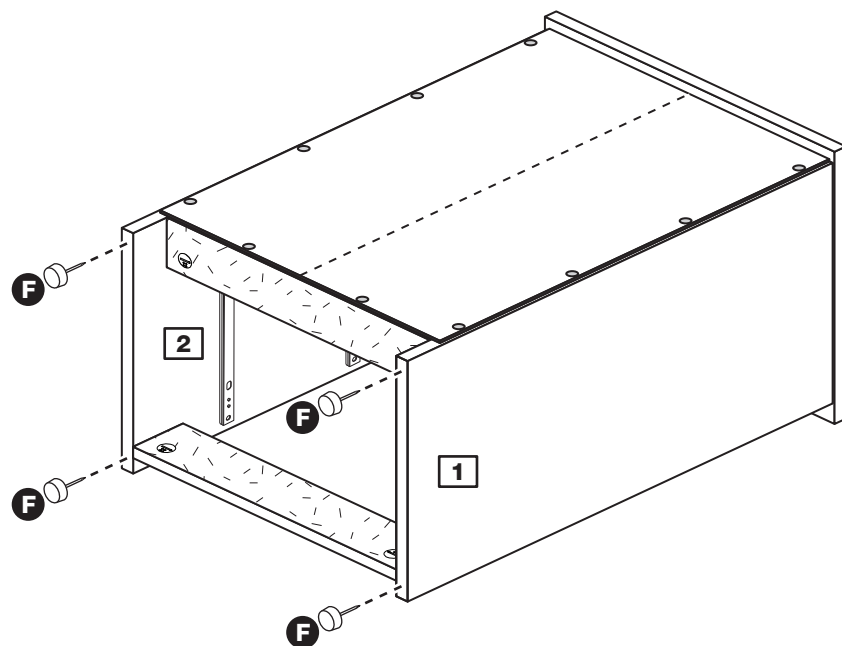

Assembly Instructions

Step 17

Fit the drawers

Starting with the bottom drawer, slide both the runners **J** forward and locate the drawer sides **7** and **8** between them, lining up the holes in the drawer wrap with the 2nd 'threaded' holes in the runners **H**.

Working from the inside of the drawer, insert 2 screws **H** through the drawer sides and out into the 2nd threaded hole in the runner.

Note: Do not overtighten the screws **H**. If they catch on the runner you may need to loosen them slightly.

Assembly is complete

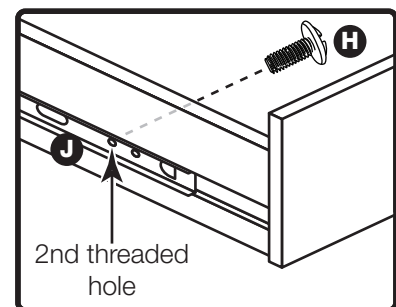
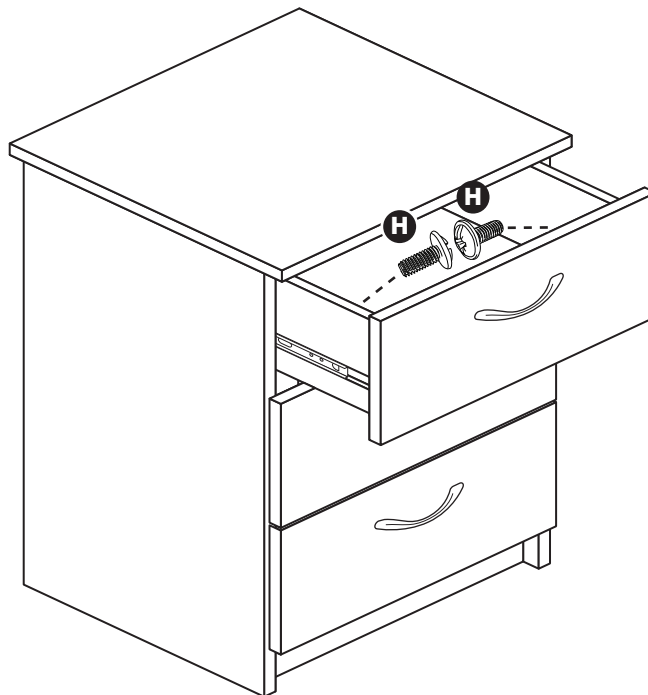

If you need help or have damaged or missing parts, call the Customer Helpline: 08456 400800 and quote the reference numbers on the component pages.

Argos Ltd, 489-499 Avebury Boulevard, Central Milton Keynes, MK9 2NW