

Hamlin - 2 Drawers Dresser

Assembly Instructions - Please keep for future reference

145/8390

152/5340

hygena

145/5726

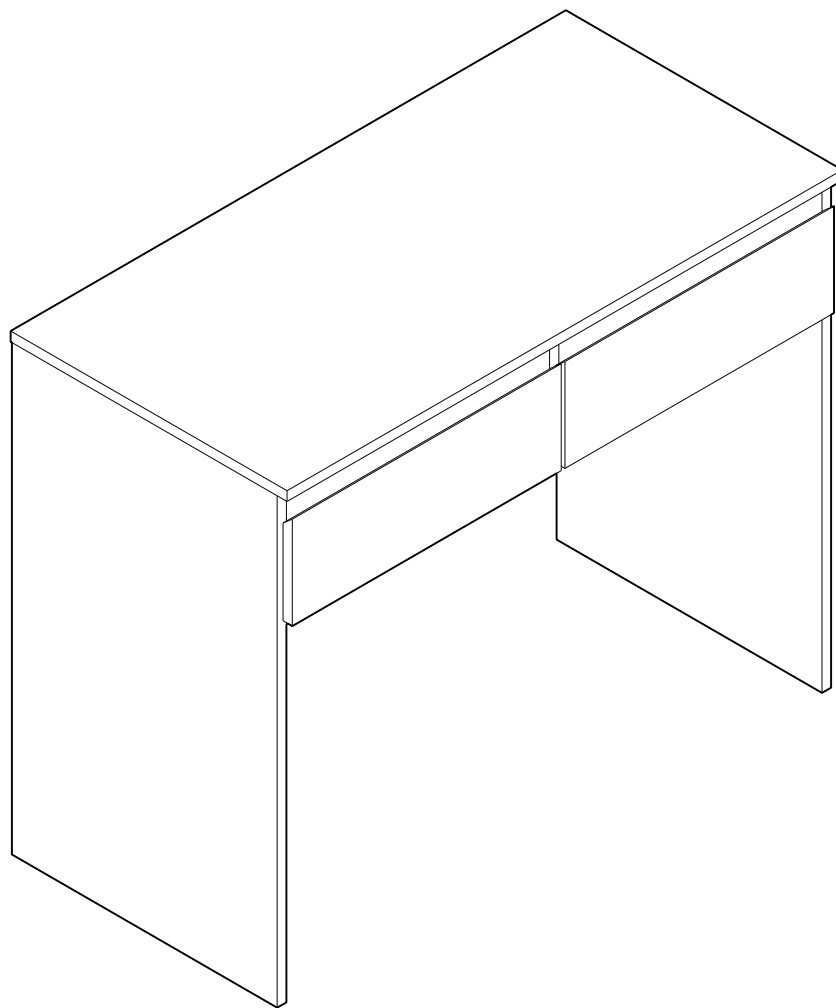

Dimensions

Width - 90cm

Depth - 44,8cm

Height - 74cm

Important – Please read these instructions fully before starting assembly

If you need help or have damaged or missing parts, call the **Customer Helpline: 08456 400 800**



Safety and Care Advice

Important – Please read these instructions fully before starting assembly

- Check you have all the components and tools listed on pages 2 and 3.
- Remove all fittings from the plastic bags and separate them into their groups.
- Keep children and animals away from the work area, small parts could choke if swallowed.
- Make sure you have enough space to layout the parts before starting.

- Do not stand or put weight on the product, this could cause damage.
- Assemble the item as close to its final position (in the same room) as possible.
- Assemble on a soft level surface to avoid damaging the unit or your floor.



- We do not recommend the use of power drill/drivers **for inserting screws**, as this could damage the unit. Only use hand screwdrivers.
- Parts of the assembly will be easier with 2 people.
- Dispose of all packaging carefully and responsibly.

Care and maintenance

- Avoid placing the furniture in direct sunlight as this will cause the timber to prematurely age.
- Use a dry cloth to clean the product, furniture polish is not recommended.
- From time to time check that there are no loose screws on this unit.
- This product should not be discarded with household waste. Take to your local authority waste disposal centre.

Note: If required the next page can be cut out and used as reference throughout the assembly. Keep this page with these instructions for future reference.

Components - Panels

Please check you have all the panels listed below



1 Top panel (90 x 44.8cm)



2 Right side panel (72 x 43cm)

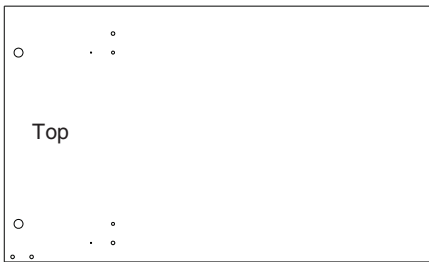

3 Left side panel (72 x 43cm)

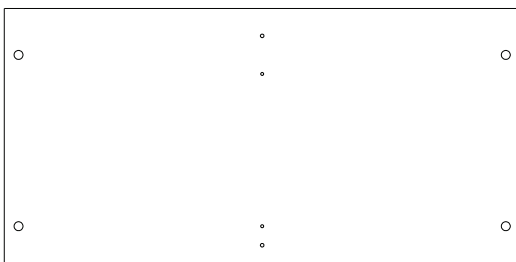

4 Base panel (86.8 x 43cm)



5 Back panel (88.8 x 19.5cm)

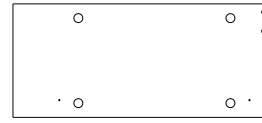

6 Middle wall panel (17.5 x 43cm)



7 Drawer front x 2 (43.6 x 15cm)



8 Drawer back x 2 (37.2 x 8cm)



9 Drawer right side x 2 (40 x 8cm)

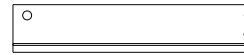

10 Drawer left side x 2 (40 x 8cm)



11 Top front frame x 2 (42.6 x 6cm)

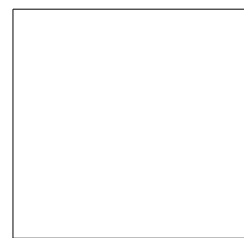

12 Drawer bottom x 2 (39.8 x 38.5cm)









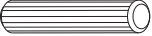
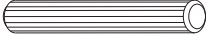
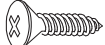
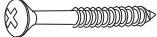

Components - Fittings

If you have damaged or missing components, call the **Customer Helpline: 08456 400 800**

Please check you have all the fittings listed below

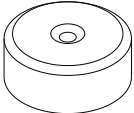
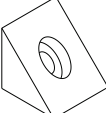
Note: The quantities below are the correct amount to complete the assembly. In some cases more fittings may be supplied than are required.

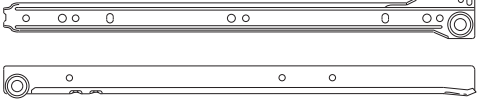
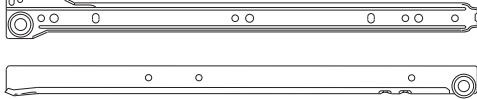
A  Ø 6X30 Wooden dowel x 24	B  Ø 6X50 Wooden dowel x 2	C  14mm Screw x 16
D  20mm Screw x 4	E  40mm Screw x 4	F  Metal dowel x 16
G  Locking nut x 16	H  Nail x 30	I  Nail x 4
J  Plastic feet x 4	K  Plastic bracket x 4	L  Plastic cap x 14
M  Right runner x 2 pair	N  Left runner x 2 pair	

Tools required

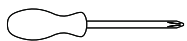

Phillips screwdriver
(small & medium)

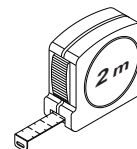

Ruler/tape
measure



Small
hammer

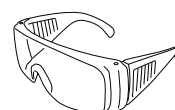

Eye protection
(when using a
hammer or glue)

Ruler - Use this ruler to help correctly identify the screws



Assembly Instructions

Step 1

Insert dowels **A** into the indicated parts.

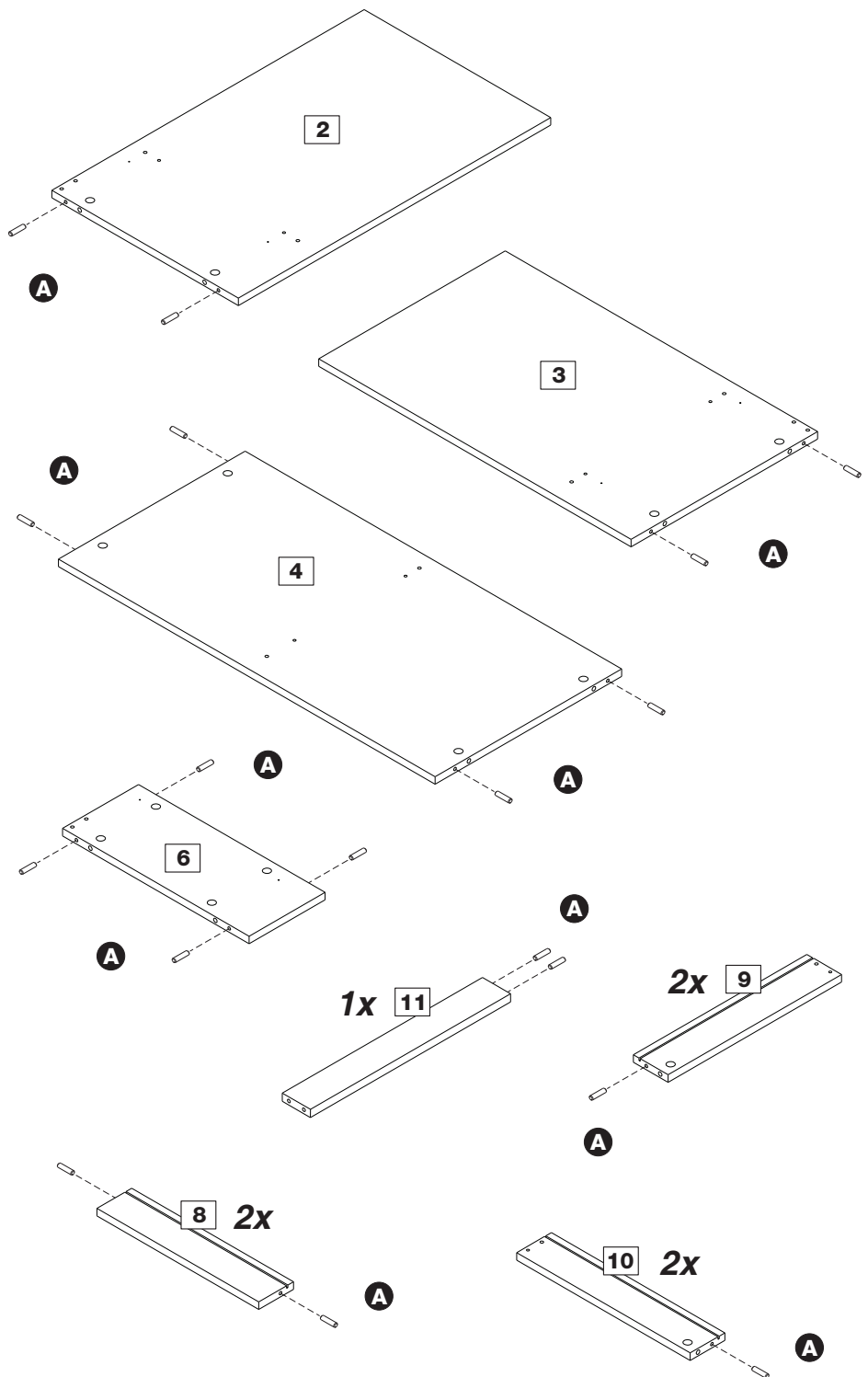

Step 2

Insert dowels **A** and **B** into the top front frame **11**, as shown.

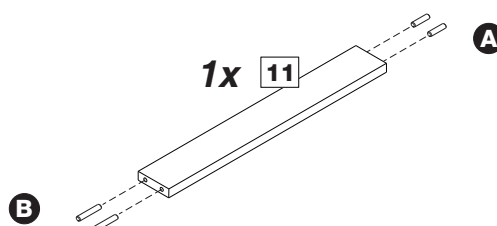

Assembly Instructions

Step 3

Fitting Metal dowels.

Screw metal dowels **F** into top panel **1**, base panel **4**, right side panel **2**, left side panel **3** and drawer fronts **7**.



Note: Insert metal dowels as far as shown.

Do not over tighten.

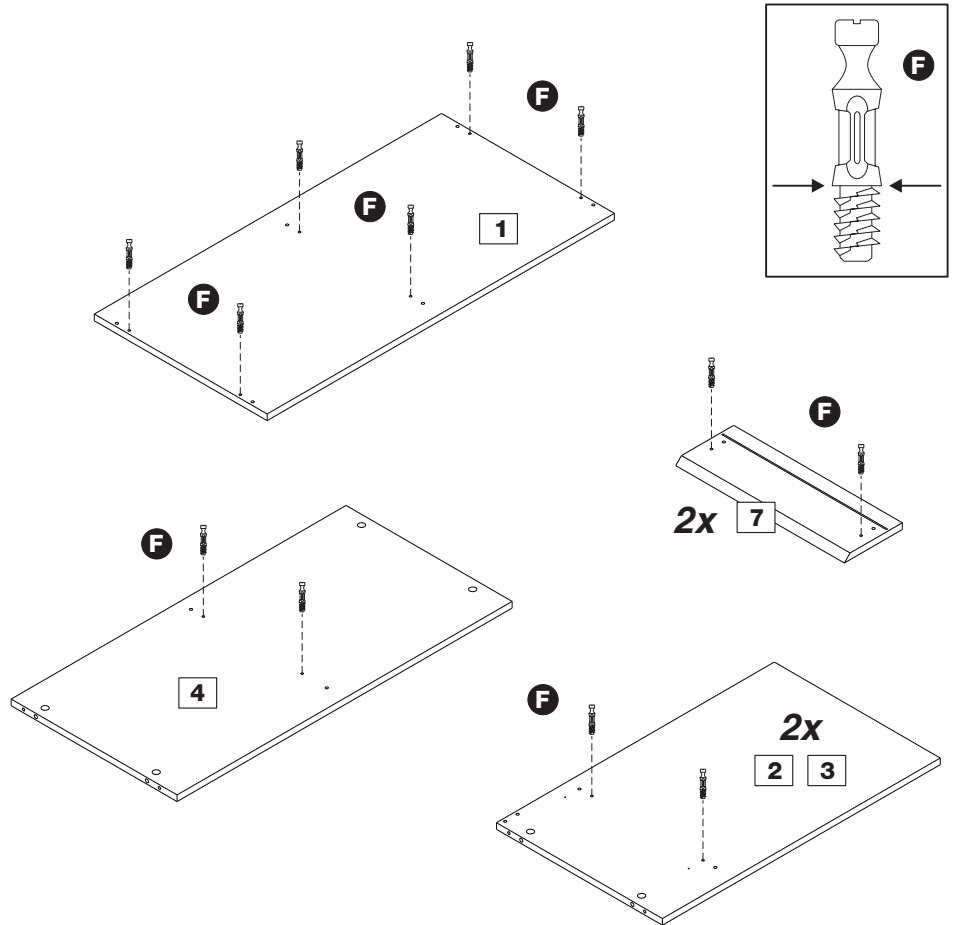

Step 4

Fixing middle wall panel.

With help, fit middle wall panel **6** to base panel **4**.

Insert 2 locking nuts **G** into middle wall panel where shown.

Use a screwdriver to turn locking nuts **G** clockwise to lock.

Do not over tighten.



Make sure finished edges of middle wall panel and base panel are facing down.

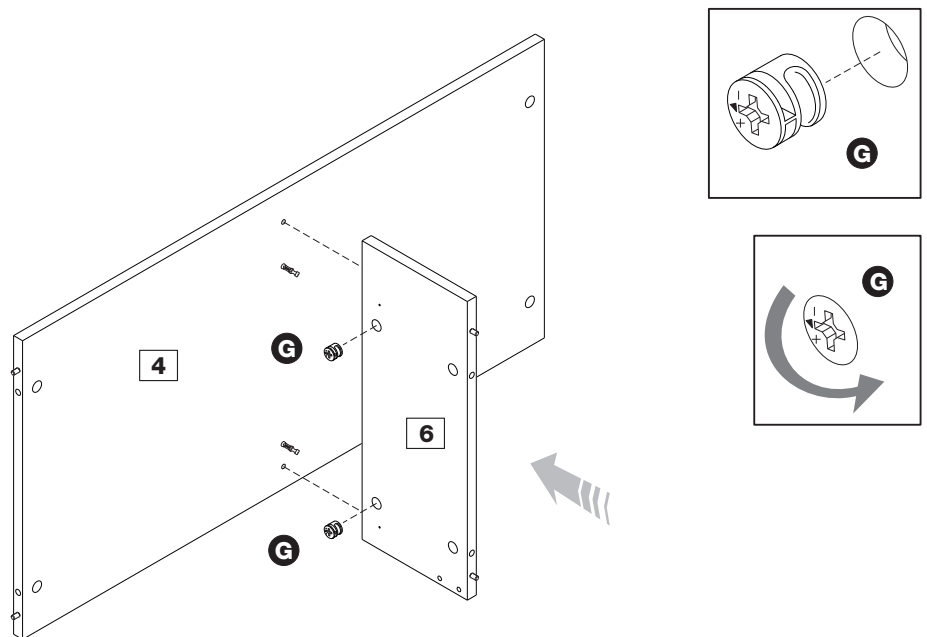

Painted edge to face down.

Assembly Instructions

Step 5

Fixing runners.

a: Attach right runner **M** to the pre drilled holes on the right side panel **2** using screws **B**.

a:

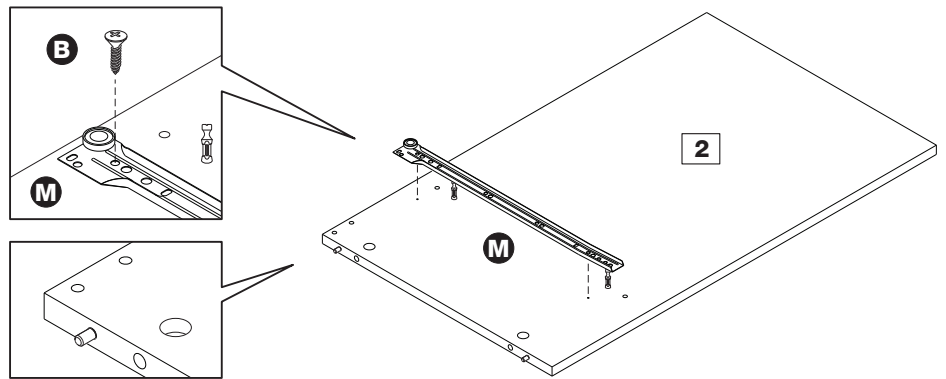

b: Attach left runner **N** to the pre drilled holes on the left side panel **3** using screws **B**.

b:

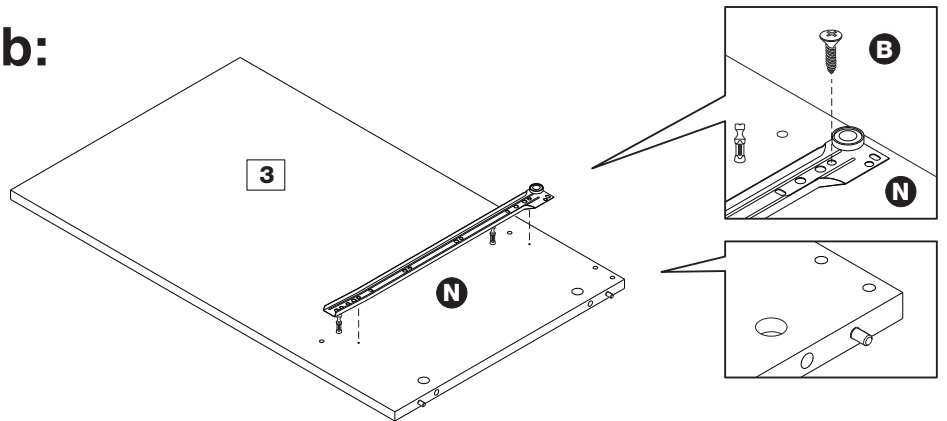

c: Attach right runner **M** to the pre drilled holes on the left side of middle wall panel **6** using screws **B**.

c:

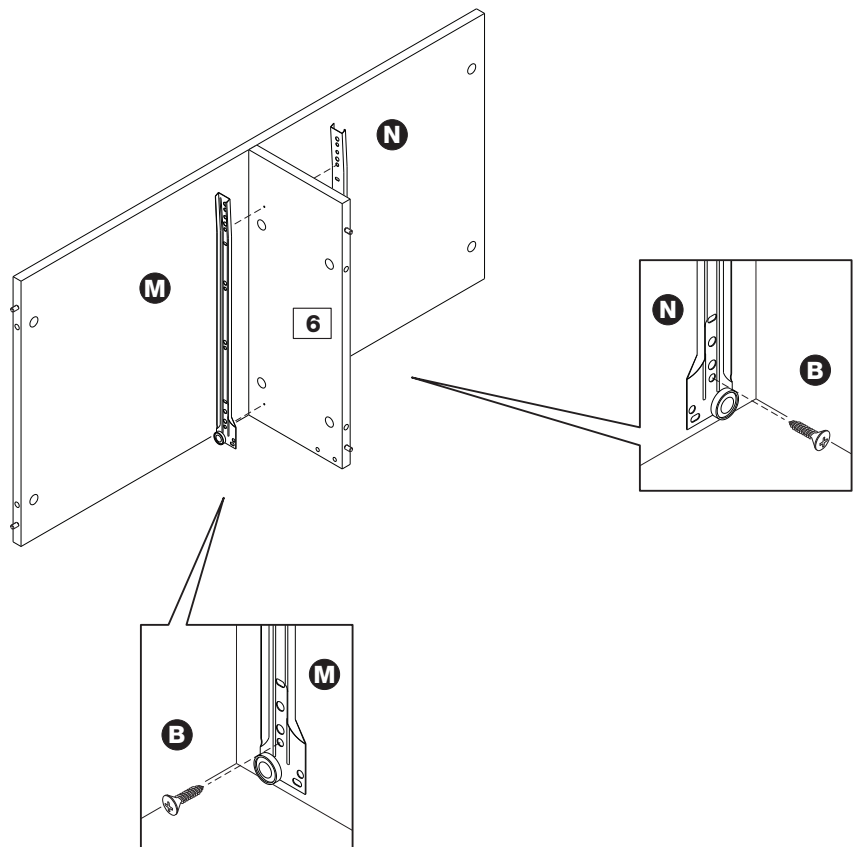

Attach left runner **N** to the pre drilled holes on the right side of middle wall panel **6** using screws **B**.

Assembly Instructions

Step 6

Fitting top front frames.

Fit top front frames **11** to middle wall.



Attention!

Top front frame with longer wooden dowel should be fitted first.

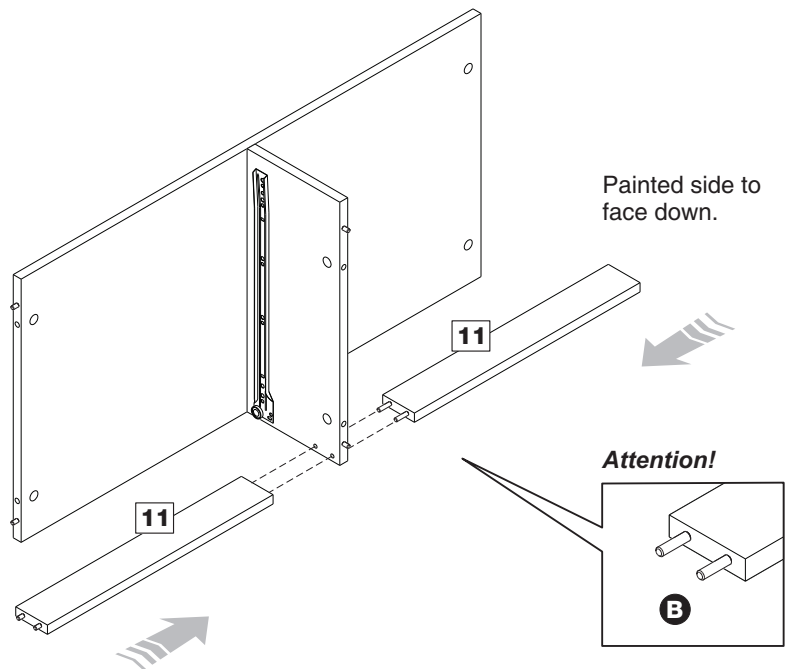

Step 7

Fixing side panels.

With help, fit right side panel **3** and left side panel **2** to base panel and top front frames.

Insert 4 locking nuts **G** into base panel where shown.

Use a screwdriver to turn locking nuts **G** clockwise to lock.

Do not over tighten.

After screwing locking nuts, insert plastic caps **L**.



Important:

After inserting plastic caps, with help, carefully stand the product upright.

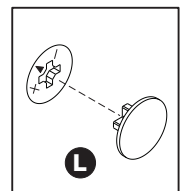
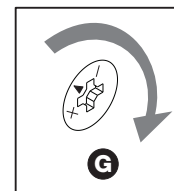
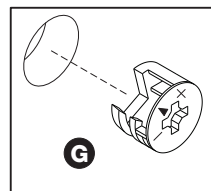
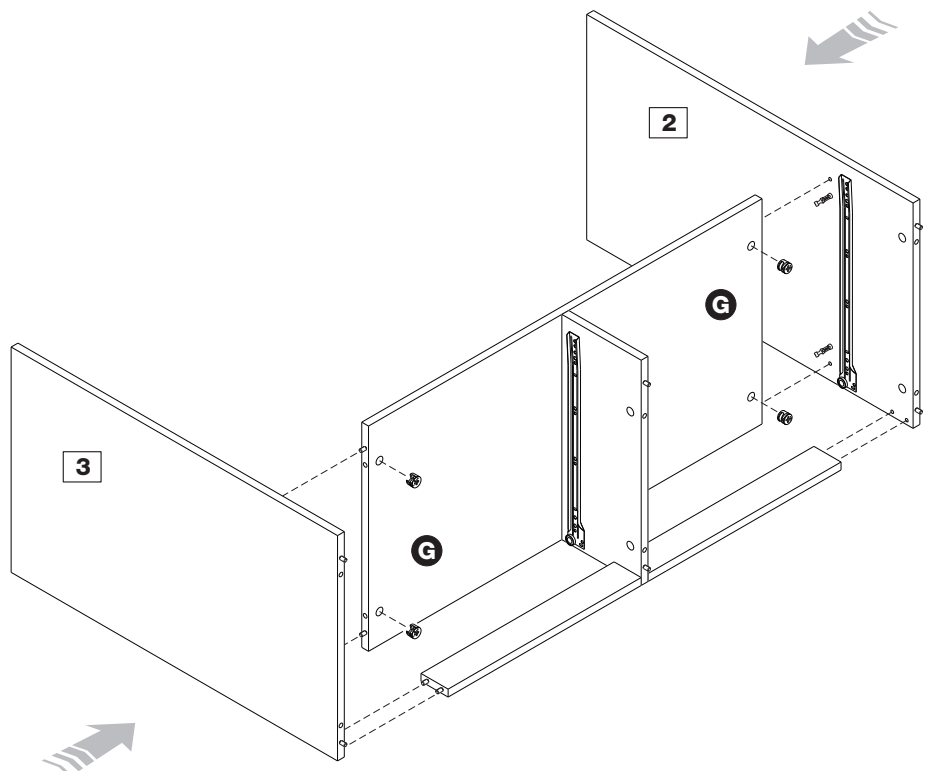

Assembly Instructions

Step 8

Fixing top panel.

With help, fit top panel **1** to the cabinet.

Insert 4 locking nuts **G** into side panels and 2 locking nuts **G** into middle wall panel where shown.

Use a screwdriver to turn locking nuts **G** clockwise to lock.

Do not over tighten.

After screwing locking nuts, insert plastic caps **L**.

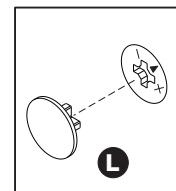
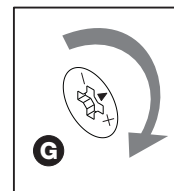
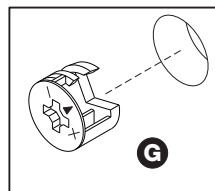
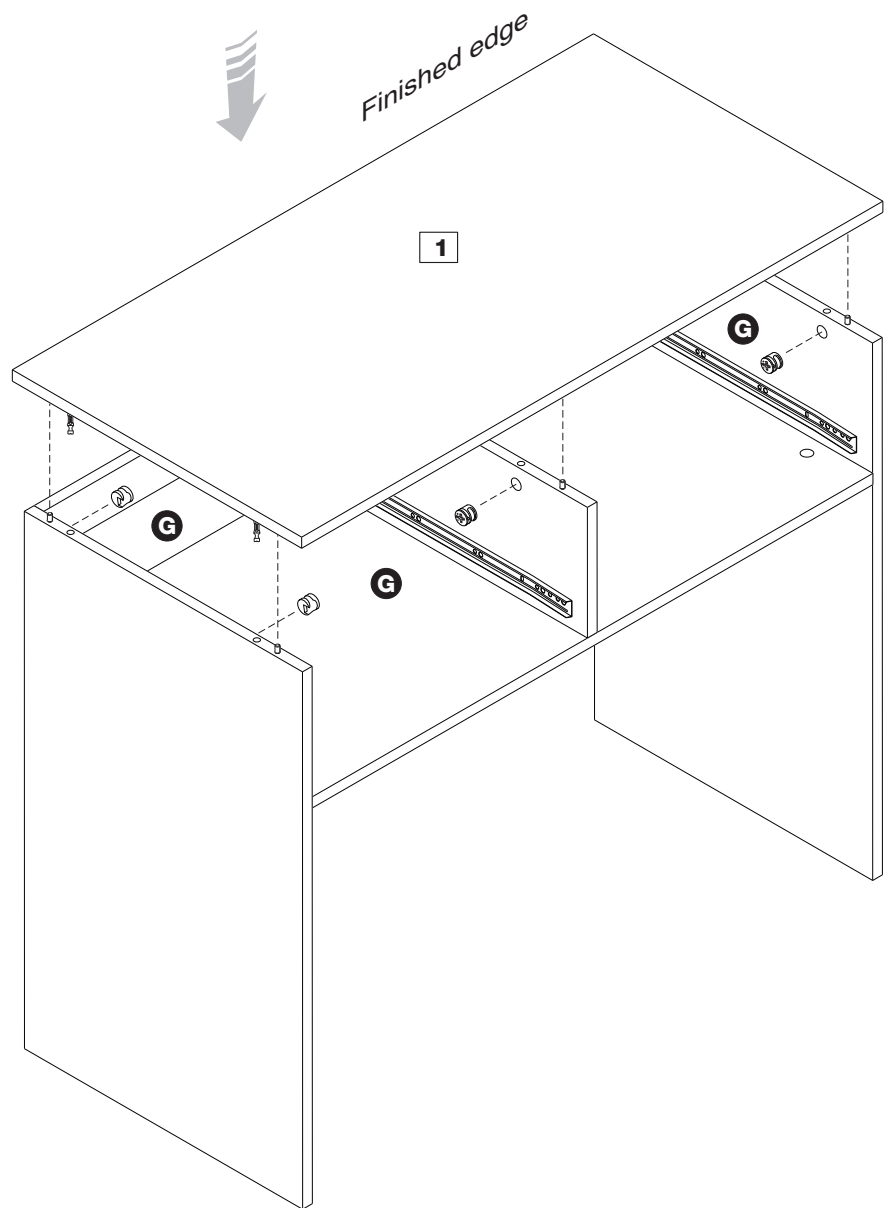

Assembly Instructions

Step 9

Fixing back panels.



Important:

Cabinet **MUST** be 'square' when back panel is attached.

Attach back panel **5** using nails **H**.

After attach back panel, with help, carefully lay down the product.

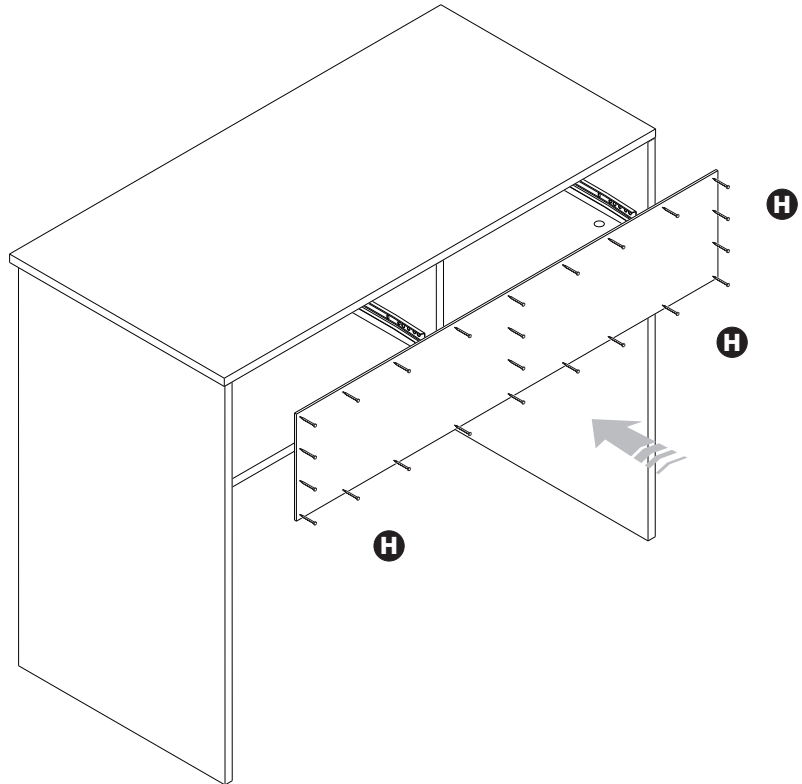
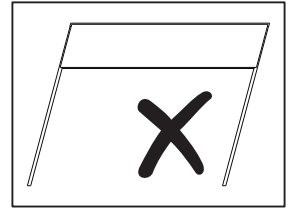
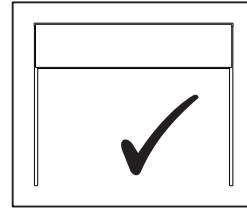

Step 10

Attach plastic feet.

Attach plastic feet **J** in the bottom edge of the right and left side panels using nails **I**.



Make sure nails are fully nailed.

After attach plastic feet, with help, carefully stand the product upright.

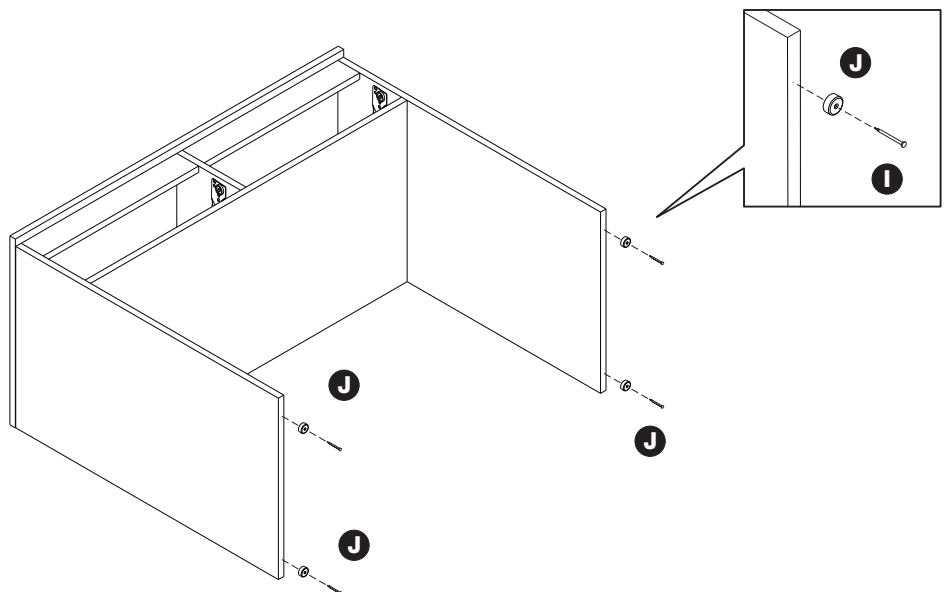

Assembly Instructions

Step 11

Drawer assembly.

a: Fix drawer sides **9** and **10** to the drawer back **8** using screws **E**.

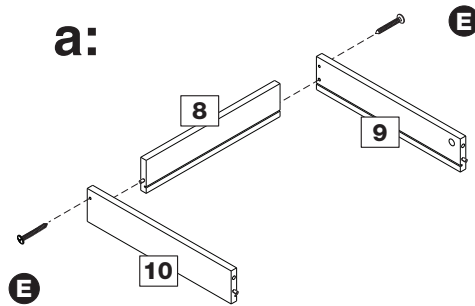

b: Slide drawer bottom **12** into slots on drawer sides.

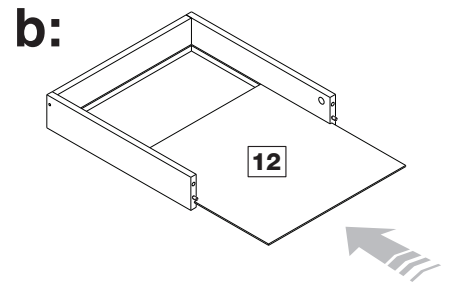

c: With help, fit drawer front **7** to the drawer sides.

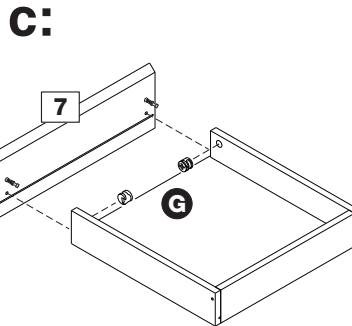

Insert 2 locking nuts **G** into drawer sides where shown.

Use a screwdriver to turn locking nuts **G** clockwise to lock.

Do not over tighten.

After screwing locking nuts, insert plastic caps **L**.

Repeat step 11 for the other drawer.

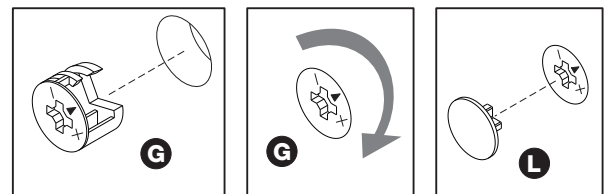

Step 12

Attach plastic bracket.

Attach plastic bracket **K** in the bottom of the drawers using screws **D**.

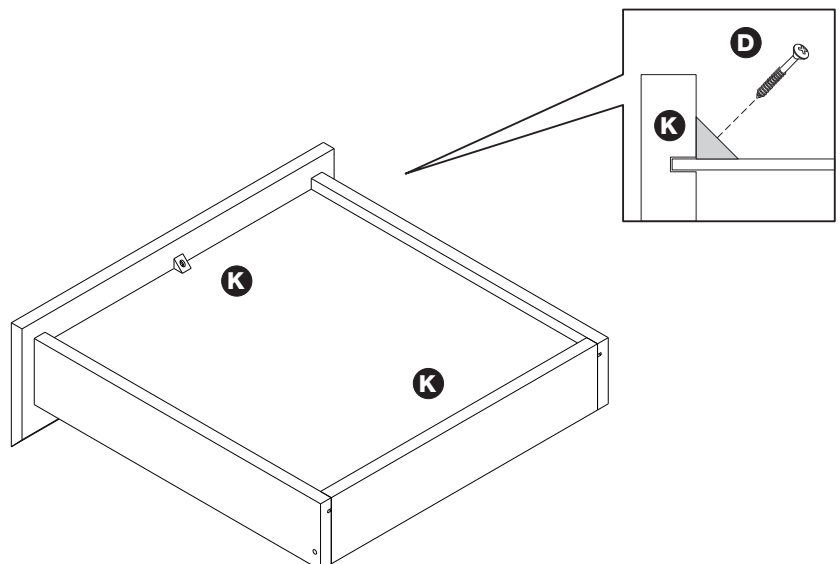

Assembly Instructions

Step 13

Fixing runners.

Attach right runners **M** and left runners **N** in the bottom edge of the drawers using screws **C**, as shown.



Make sure runners are correctly positioned according to the diagram prior to fixing.

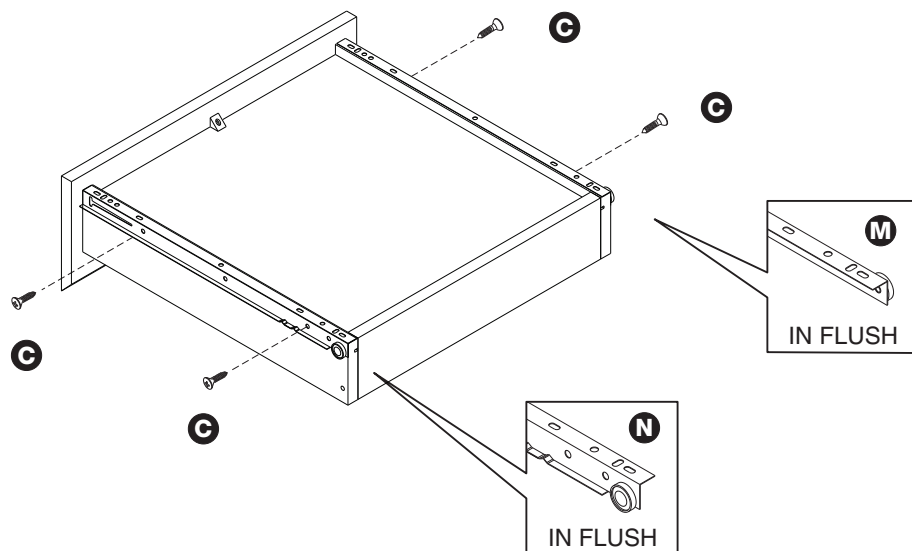
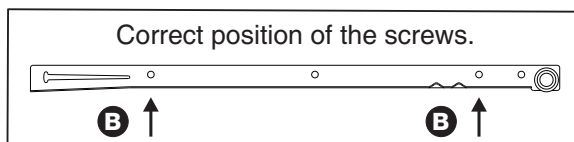

Step 14

Hook the wheels of the runner on the back of the drawers over the wheels of the runners on the left and right sides, then hold the drawers level and slide backwards into position.

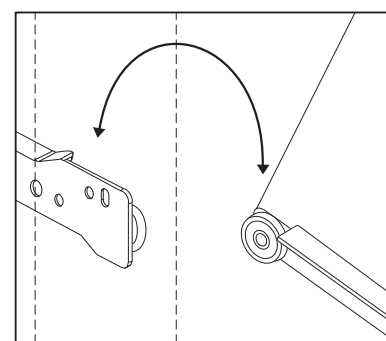
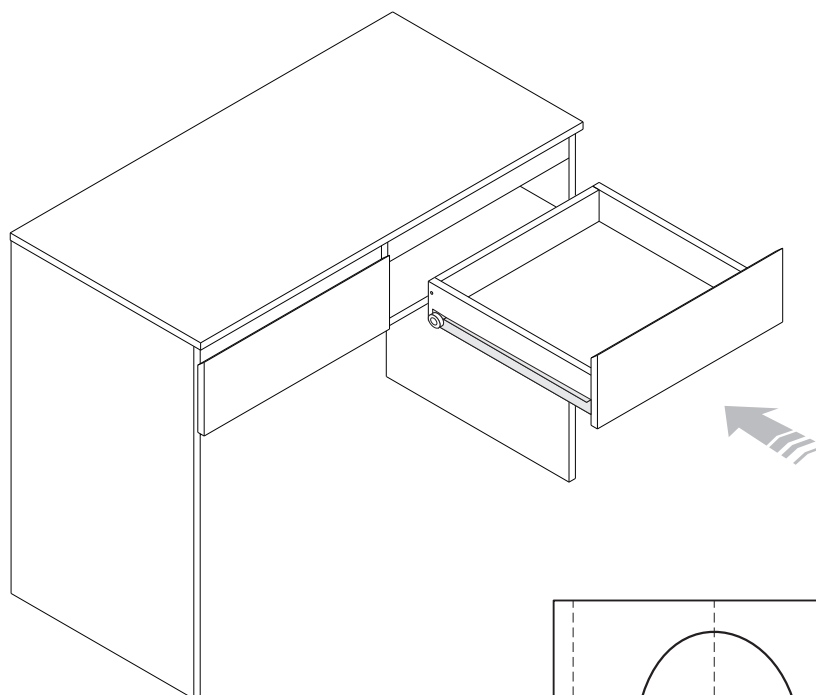

Assembly is complete.

If you need help or have damaged or missing parts, call the **Customer Helpline: 08456 400 800**