

Atlas - 4 Drawer Chest

Assembly Instructions - Please keep for future reference

181/6815

146/7233

171/5129

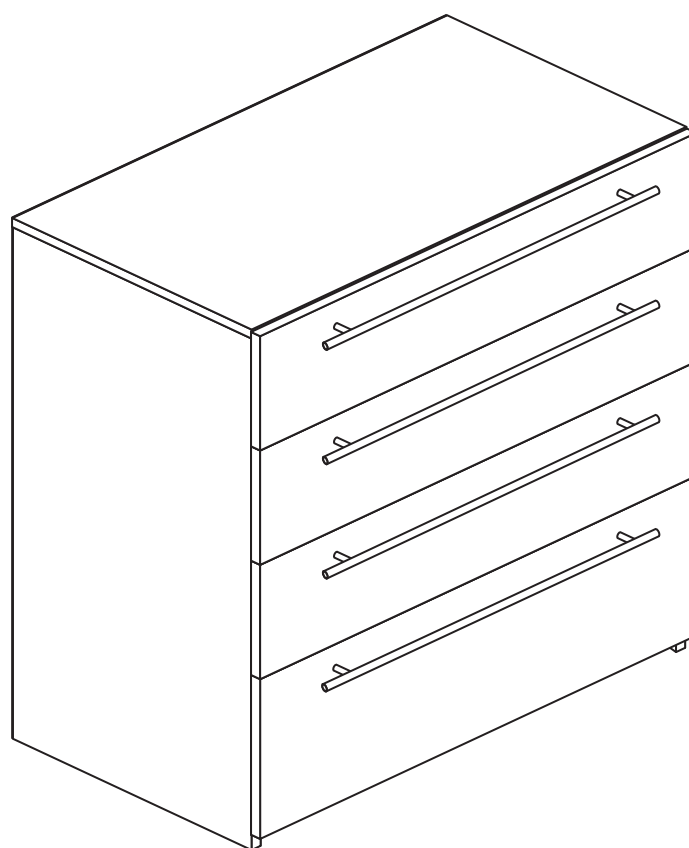

Dimensions

Width - 79.5cm

Depth - 41.5cm

Height - 86cm



**MADE IN
BRITAIN**

Important - Please read these instructions fully before starting assembly

If you need help or have damaged or missing parts, call the **Customer Helpline: 08456 400800**



Safety and Care Advice

Important - Please read these instructions fully before starting assembly

- **Warning:** This unit weighs approximately 31kgs. Please lift with care.

- Check you have all the components and tools listed on pages 2 and 3.

- Remove all fittings from the plastic bags and separate them into their groups.

- Keep children and animals away from the work area, small parts could choke if swallowed.

- Parts of the assembly will be easier with 2 people.

- Make sure you have enough space to layout the parts before starting.

- Do not stand or put weight on the product, this could cause damage.

- Assemble the item as close to its final position (in the same room) as possible.

- Assemble on a soft level surface to avoid damaging the unit or your floor (use opened out unit carton).



- We do not recommend the use of power drill/drivers **for inserting screws**, as this could damage the unit. Only use hand screwdrivers.

- **Safety note:** If there is any chance of this unit being pulled over by children etc. it is recommended that the unit is secured to a wall using suitable fixings (not supplied).

- Dispose of all packaging carefully and responsibly.

Care and maintenance

- Only clean using a damp cloth and mild detergent, do not use bleach or abrasive cleaners.

- From time to time check that there are no loose screws on this unit.

- This product should not be discarded with household waste. Take to your local authority waste disposal centre.

Note: If required the next page can be cut out and used as reference throughout the assembly. Keep this page with these instructions for future reference.

Components - Panels

If you have damaged or missing components, call the **Customer Helpline: 08456 400800** quoting the reference numbers below

Please check you have all the panels listed below

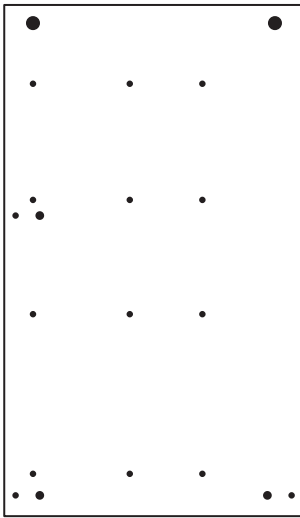

1 Left Side (D2390A)
(845 x 395mm)

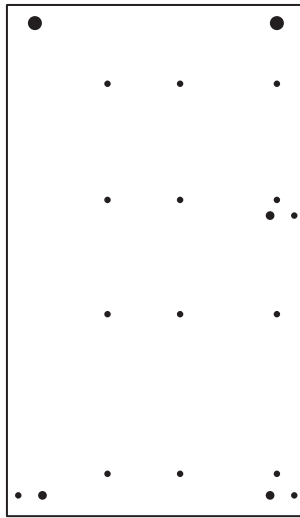

2 Right Side (D2391A)
(845 x 395mm)

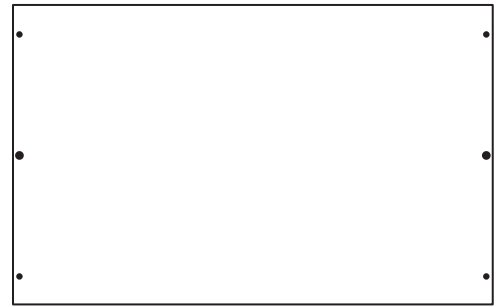

3 Top (D2389A)
(793 x 396mm)

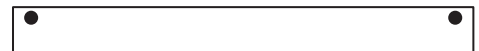

4 Rail (D2392A)
(761 x 60mm) x 3

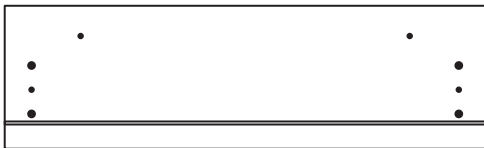

5 Small Drawer Front (D2393A)
(795 x 189mm) x 3

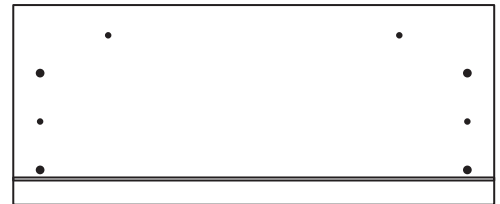

6 Large Drawer Front (D2394A)
(795 x 264mm)

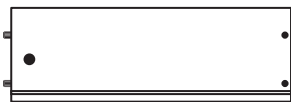

7 Small Left Drawer Side (W370-124LH)
(370 x 124mm) x 3

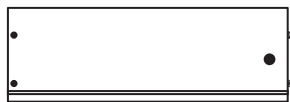

8 Small Right Drawer Side (W370-124RH)
(370 x 124mm) x 3

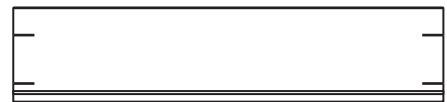

9 Small Wrap Back (W711-124)
(711 x 124mm) x 3

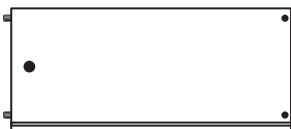

10 Large Left Drawer Side (W370-165LH)
(370 x 165mm)



11 Large Right Drawer Side (W370-165RH)
(370 x 165mm)



12 Large Wrap Back (W711-165)
(711 x 165mm)



13 Drawer Base (T722-367)
(722 x 367mm) x 4



14 Back (X836-787)
(836 x 787mm)











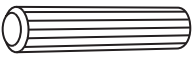
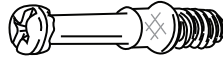

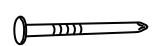

Components - Fittings

If you have damaged or missing components, call the **Customer Helpline: 08456 400800** quoting the reference numbers below

Please check you have all the fittings listed below

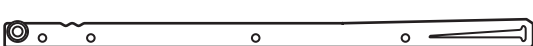
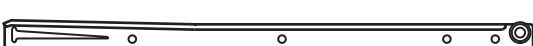
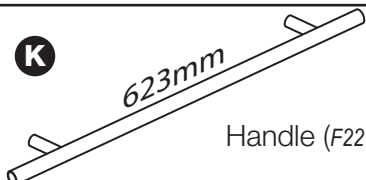
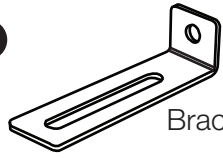
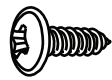
Note: The quantities below are the correct amount to complete the assembly. In some cases more fittings may be supplied than are required.

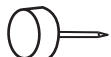
<p>A </p> <p>Wooden dowel (F22) x 8</p>	<p>B </p> <p>Metal dowel (F901) x 18</p>	<p>C </p> <p>Large locking nut (F900) x 10</p>
<p>D </p> <p>Small locking nut (F3) x 8</p>	<p>E </p> <p>19mm Screw (F461) x 8</p>	<p>F </p> <p>13mm Screw (F52) x 24</p>
<p>G </p> <p>13mm Screw (F63) x 24</p>	<p>H </p> <p>Nail (F51) x 22</p>	<p>I </p> <p>Knock-in Peg (F171) x 16</p>
<p>J a  L Runner (F159) x 4  350mm long</p> <p>J b  R Runner (F160) x 4</p> <p>J c  L Runner (F161) x 4</p> <p>J d  R Runner (F162) x 4</p>		<p>K  623mm Handle (F227) x 4</p> <p>L  Bracket (F327) x 1</p>
<p>M </p> <p>13mm Screw (F79) x 1</p>	<p>N </p> <p>Wedgefix (F639) x 16</p>	<p>O </p> <p>Plastic Nail (F91) x 4</p>

Tools required



Rule



Cross-head screwdriver



Scissors



Hammer



Eye protection (when using a hammer or drill)

Ruler - Use this ruler to help correctly identify the screws

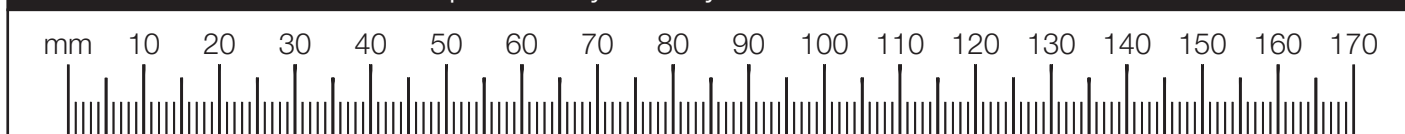

Assembly Instructions

If you have damaged or missing components, call the
Customer Helpline: 08456 400800 quoting the reference
numbers below

Step 1

Prepare the small drawer fronts

Screw 2 metal dowels **B** into the holes shown on the back of each small drawer front **5**.

Note: Tighten the metal dowels up fully against the panels.

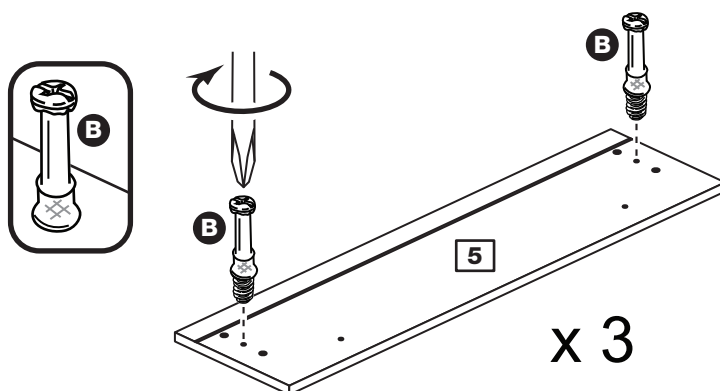

Step 2

Prepare the small drawer sides

Insert a small locking nut **D** into the hole shown on each small left drawer side **7** and small right drawer side **8**.

Note: The arrow on the locking nut **must** point towards the hole in the edge of the panel.

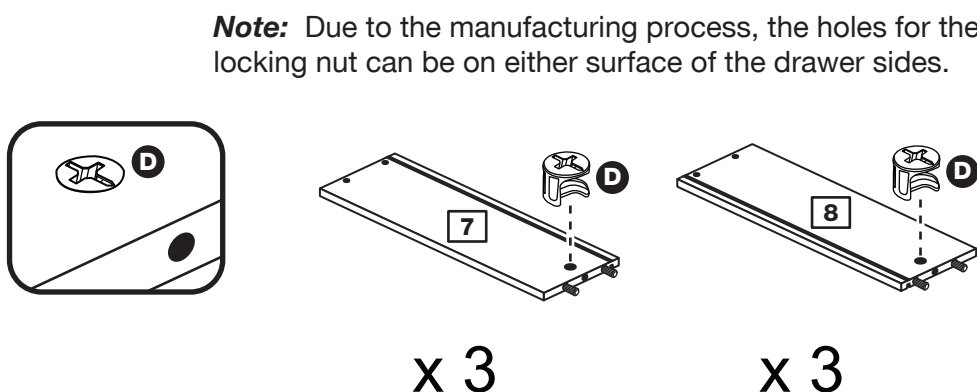

Step 3

Attach the drawer sides to the drawer fronts

Push the small left drawer sides **7** and small right drawer sides **8** onto the back of the small drawer fronts **5**.

Turn the small locking nuts **D** on the small left drawer sides **7** and small right drawer sides **8**.

Note: Turn the locking nuts **D** clockwise to secure panels - more than 1/2 a turn.

Note: The locking nuts can be on either surface of the drawer sides. Make sure that the groove is on the inside, as shown.

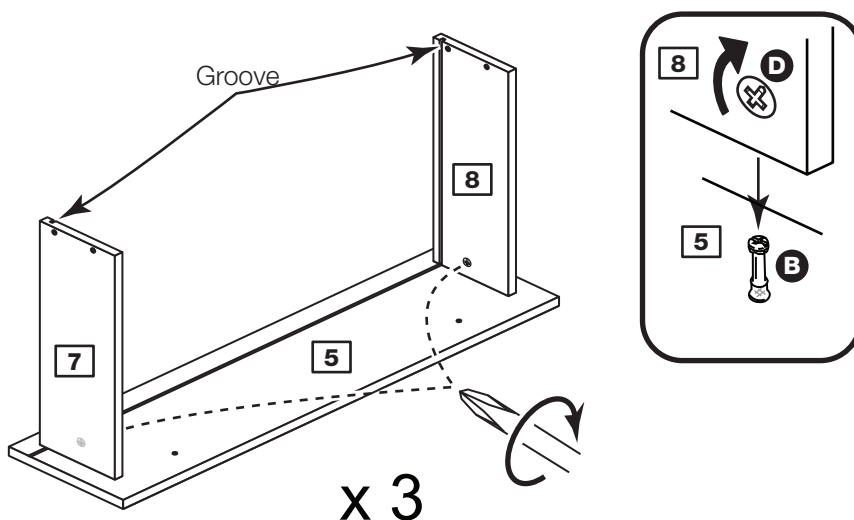

Step 4

Fit the drawer bases

Slide the drawer base **13** down the grooves in the small drawer sides **7** and **8** and down into the groove in the small drawer fronts **5**.

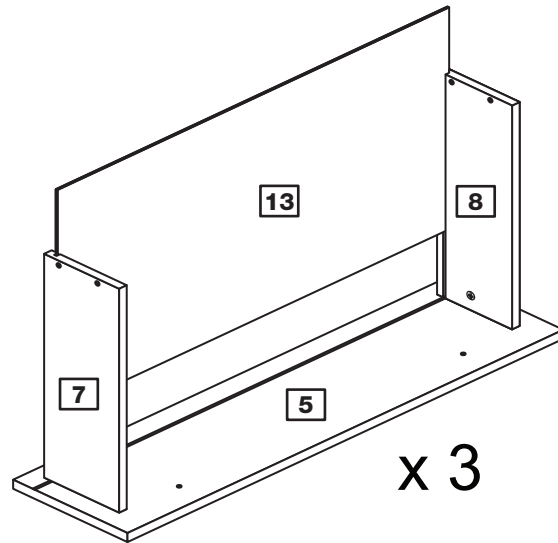

Step 5

Fit the small drawer backs

Fit the small drawer back **9** between the small drawer sides **7** and **8**.

Make sure that the drawer base **13** fits into the groove in the small drawer back **9**.

Hold the small drawer back **9** in position and tap the knock-in pegs **I** through the holes in the small drawer sides **7** and **8**.

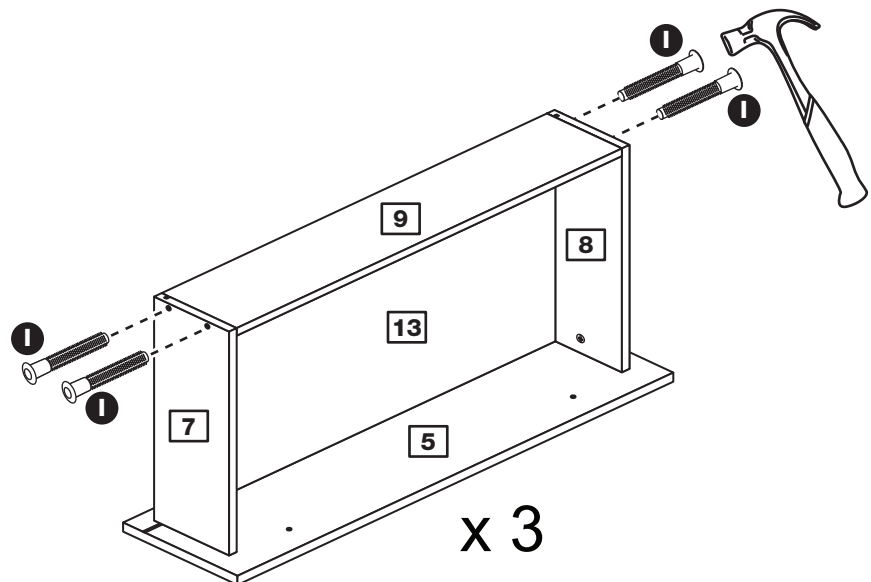

Step 6

Attach the handles

Attach handles **K** to the small drawer fronts **5** using 2 screws **E**.

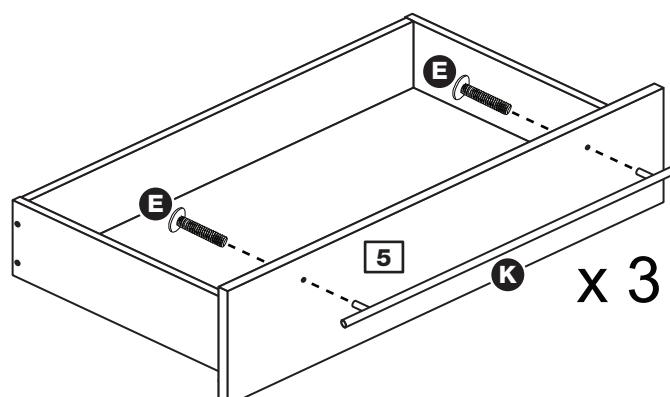

Assembly Instructions

Step 7

Fit runners to the small drawers

Turn the small drawer assemblies over.

Fit runner **Jd**, marked with 'R', to the bottom edge of the small right drawer side **8**, as shown, making sure that it is pushed up against the back of the small drawer front **5**. Use a bradawl to mark the fixing positions, then secure with 2 screws **G**.

Fit runner **Jc**, marked 'L', to the bottom edge of the small left drawer side **7** using the same method.

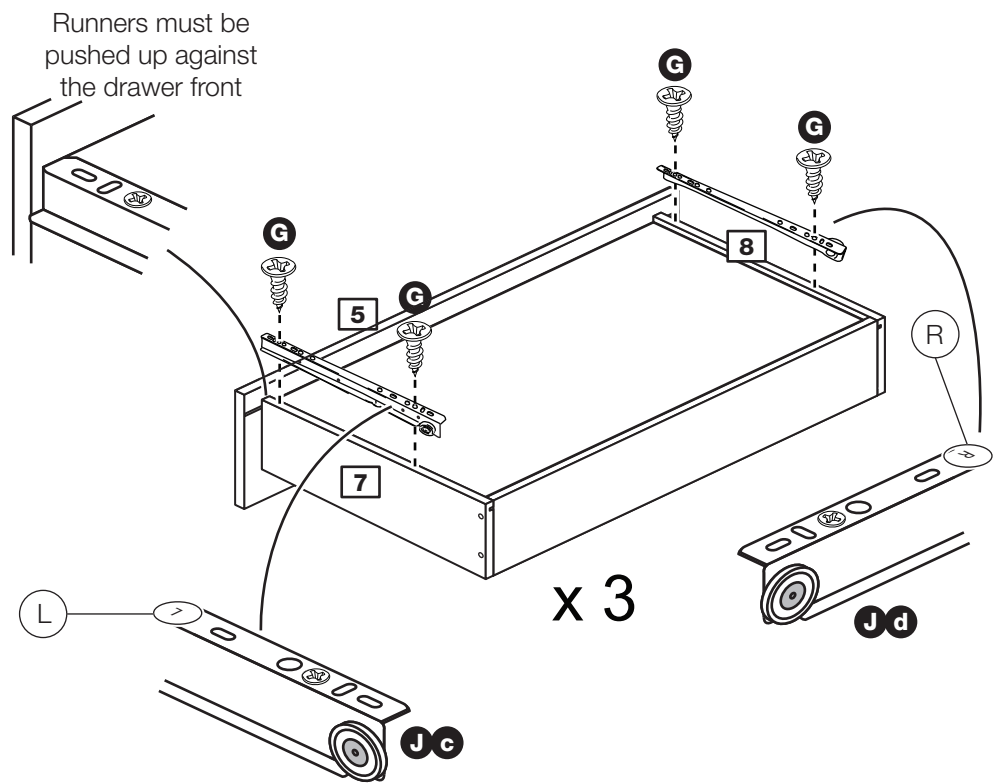

Step 8

Fit the wedgfixes

Slide 2 wedgfixes **N** into the small groove located on the back of the drawer front **5** and 2 into the small groove in the drawer back **9**.

Once in place, tighten up the screws in the wedgfixes **N**.

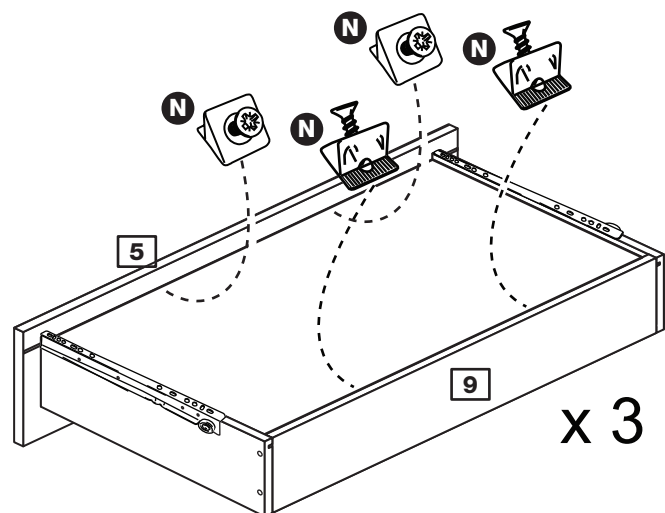

Step 9

Prepare the large drawer front

Screw 2 metal dowels **B** into the holes shown on the back of the large drawer front **6**.

Note: Tighten the metal dowels up fully against the panels.

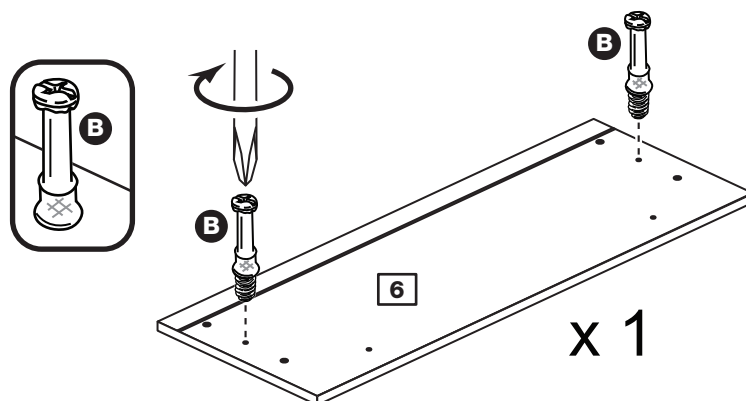

Assembly Instructions

Step 10

Prepare the large drawer sides

Insert a small locking nut **D** into the hole shown on the large left drawer side **10** and large right drawer side **11**.

Note: The arrow on the locking nut **must** point towards the hole in the edge of the panel.

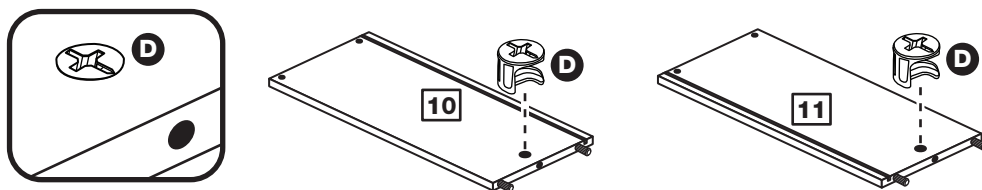

Step 11

Attach the drawer sides to the drawer front

Push the large left drawer side **10** and large right drawer side **11** onto the back of the large drawer front **6**.

Turn the small locking nuts **D** on the large left drawer side **10** and large right drawer side **11**.

Note: Turn the locking nuts **D** clockwise to secure panels - more than 1/2 a turn.

Note: The locking nuts can be on either surface of the drawer sides. Make sure that the groove is on the inside, as shown.

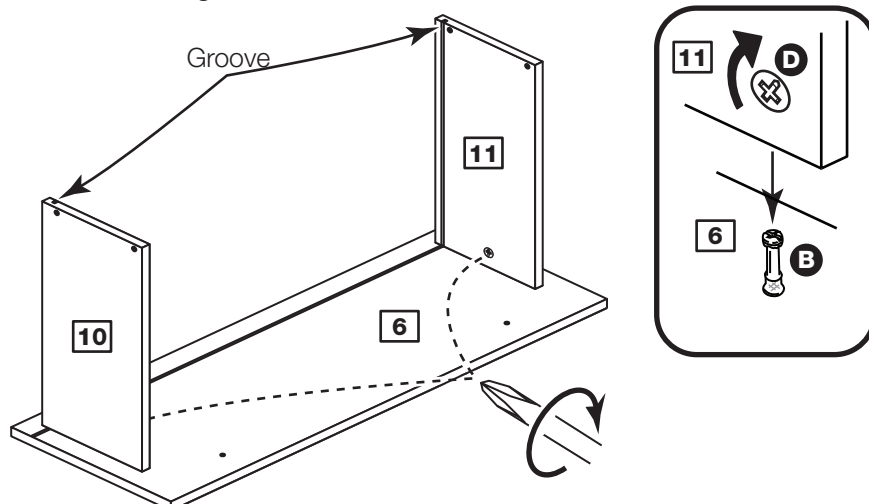

Step 12

Fit the drawer base

Slide the drawer base **13** down the grooves in the large drawer sides **10** and **11** and down into the groove in the large drawer front **6**.

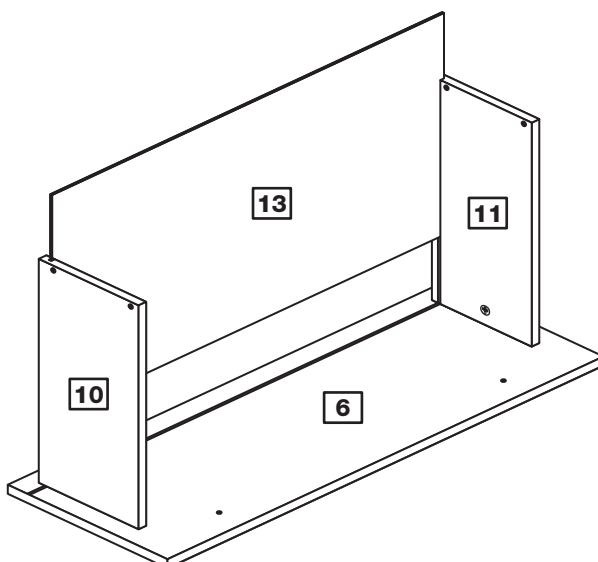

Assembly Instructions

Step 13

Fit the large drawer back

Fit the large drawer back **12** between the large drawer sides **10** and **11**.

Make sure that the drawer base **13** fits into the groove in the large drawer back **12**.

Hold the large drawer back **12** in position and tap the knock-in pegs **I** through the holes in the large drawer sides **10** and **11**.

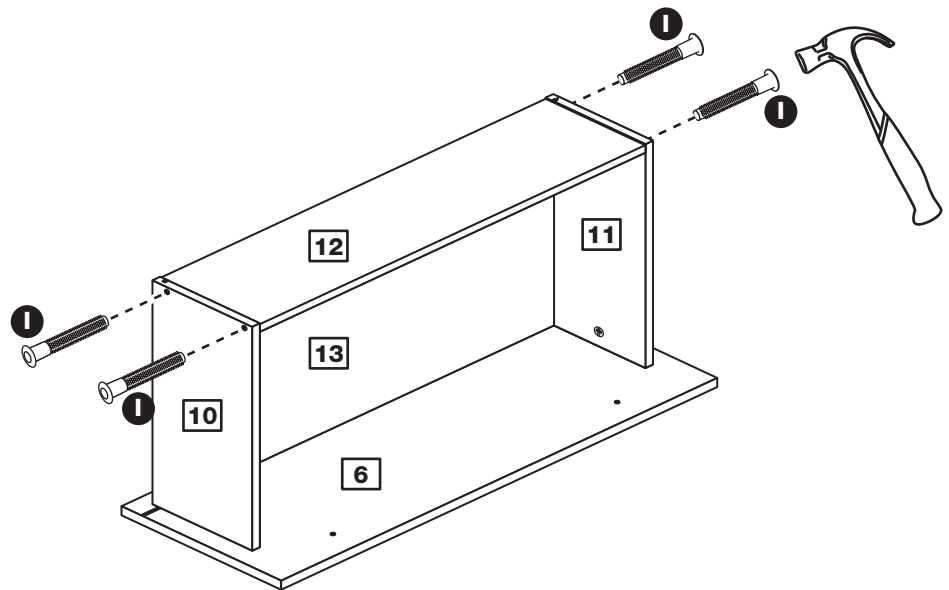

Step 14

Attach the handle

Attach a handle **K** to the large drawer front **6** using 2 screws **E**.

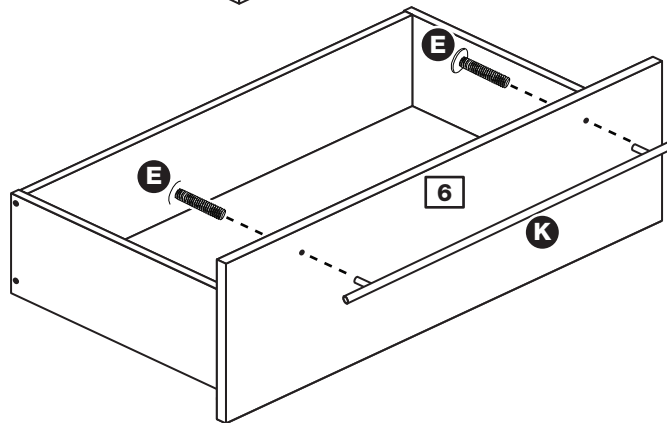

Step 15

Fit runners to the large drawer

Turn the large drawer assembly over.

Fit runner **Jd**, marked with 'R', to the bottom edge of the large right drawer side **11**, as shown, making sure that it is pushed up against the back of the large drawer front **6**. Use a bradawl to mark the fixing positions, then secure with 2 screws **G**.

Fit runner **Jc**, marked 'L', to the bottom edge of the large left drawer side **10** using the same method.

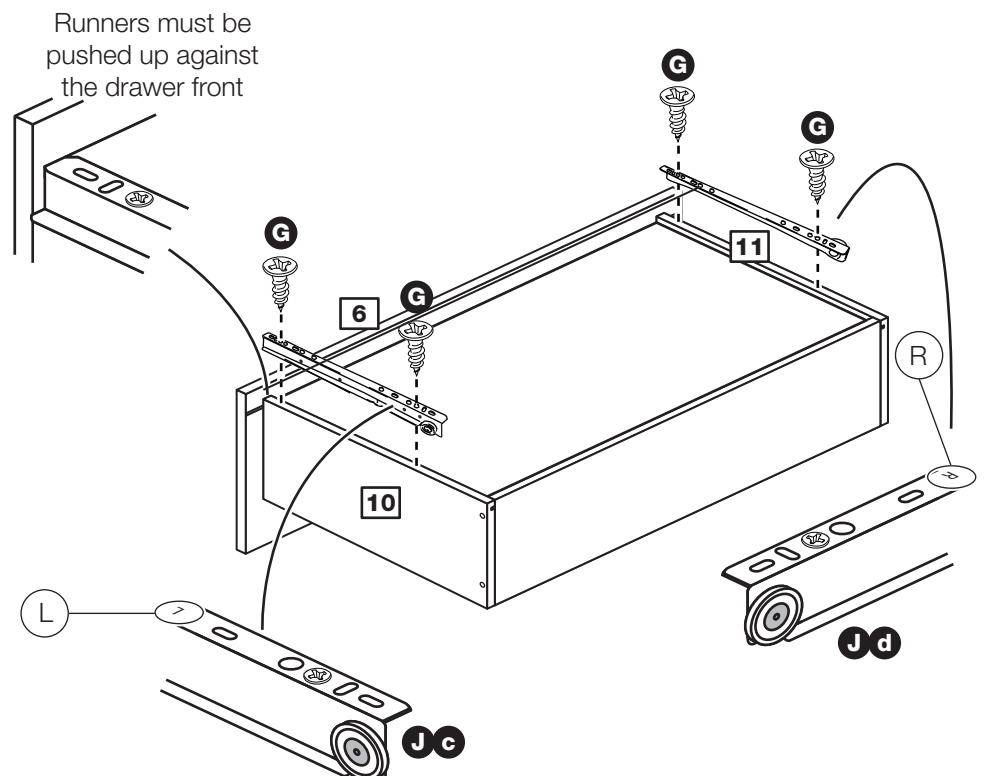

Assembly Instructions

Step 16

Fit the wedgfixes

Slide 2 wedgfixes **N** into the small groove located on the back of the drawer front **6** and 2 into the small groove in the drawer back **12**.

Once in place, tighten up the screws in the wedgfixes **N**.

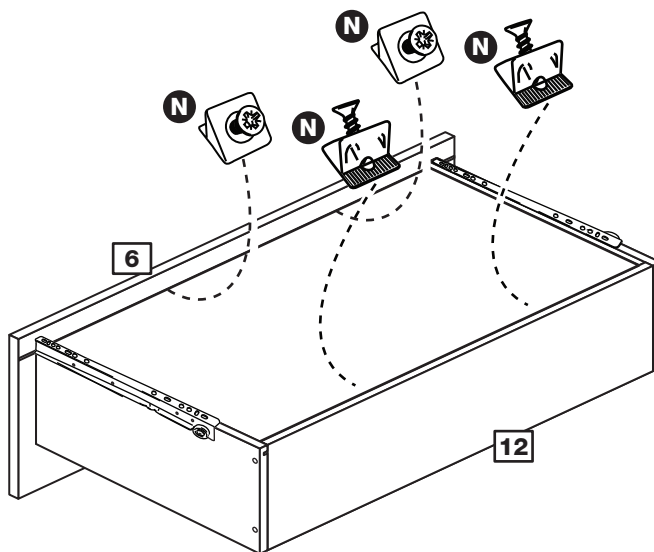

Step 17

Prepare the top

Screw 4 metal dowels **B** into the top **3**.

Fix a bracket **L** to the top **3**.

The bracket **L** must be flush against the back edge.

Secure the bracket **L** using screw **M**.

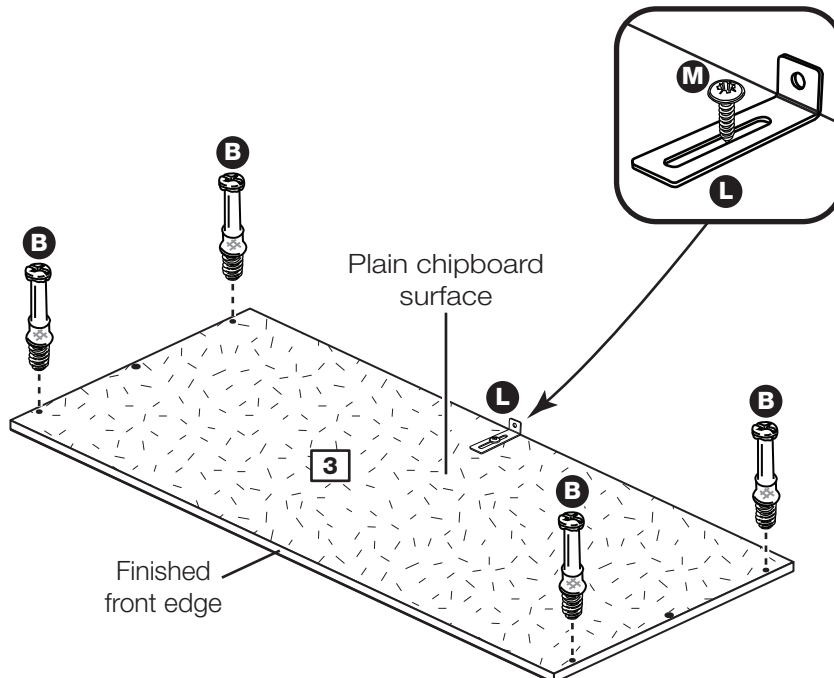

Assembly Instructions

Step 18

Prepare the left side

a: Fit runner **Ja** to the left side **1**.

The 1st screw **F** uses the 2nd hole in from the front of the runner.

The 2nd and 3rd screws **F** use the holes that line up with the other panel holes.

b: Fit a screw **G** into the 2nd hole in at the top of the runner **Ja**.

Screw 3 metal dowels **B** into the left side **1**.

Insert 2 large locking nuts **C** into the left side **1**.

Note: The arrow on the locking nut **must** point towards the hole in the edge of the panel.

Tap a wooden dowel **A** into the left side **1**.

Note: Wooden dowels **must not** stick out from the edge by more than 10mm or they may damage other panels.

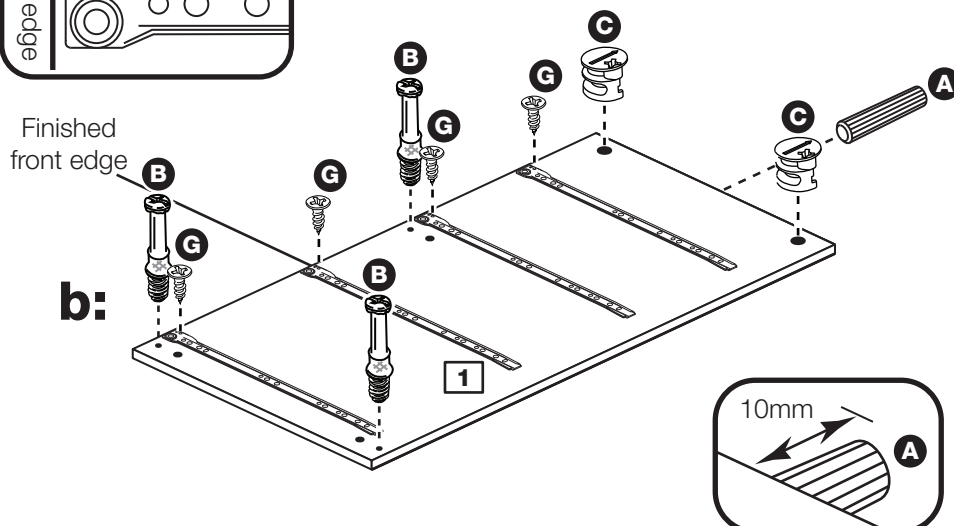
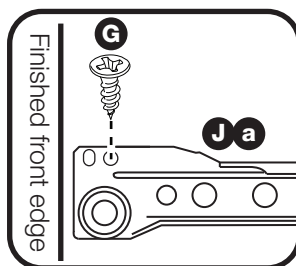
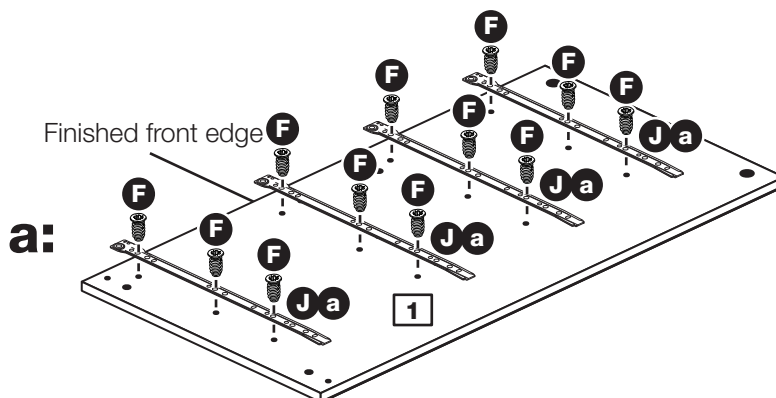
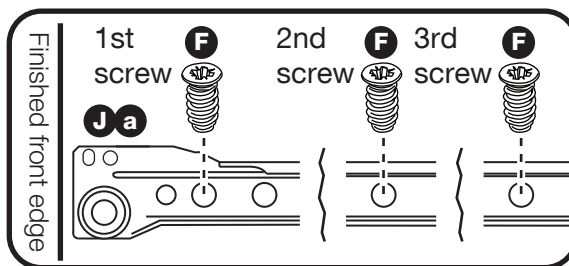

Assembly Instructions

Step 19

Prepare the right side

a: Fit runner **Jb** to the right side **2**.

The 1st screw **F** uses the 2nd hole in from the front of the runner.

The 2nd and 3rd screws **F** use the holes that line up with the other panel holes.

b: Fit a screw **G** into the 2nd hole in at the top of the runner **Jb**.

Screw 3 metal dowels **B** into the right side **2**.

Insert 2 large locking nuts **C** into the right side **2**.

Tap a wooden dowel **A** into the right side **2**.

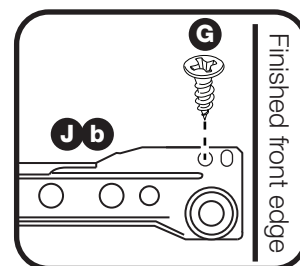
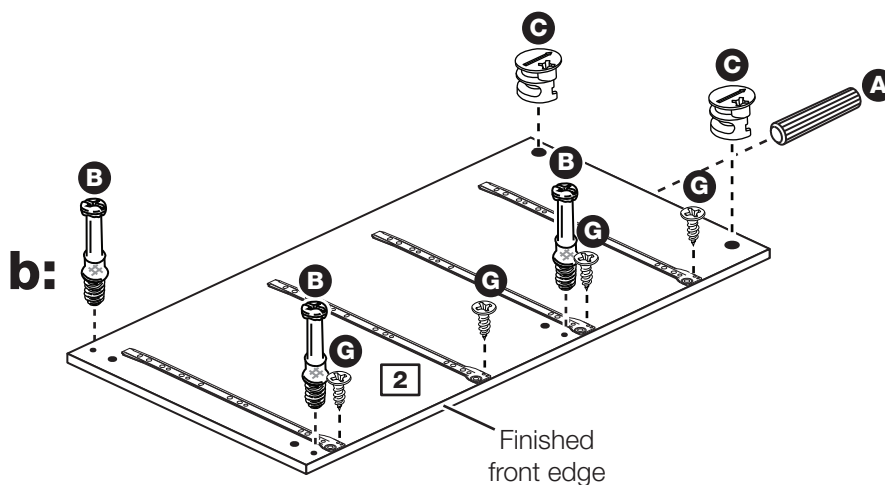
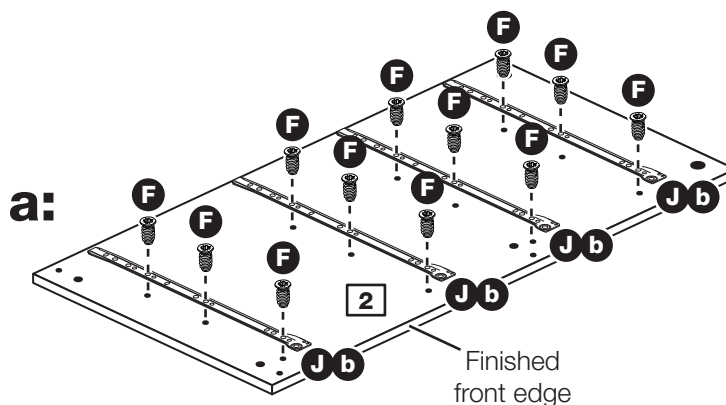
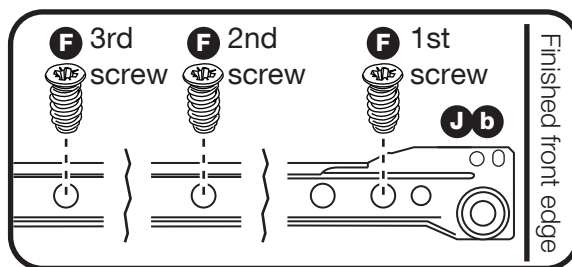

Assembly Instructions

Step 20

Fit the top

Push the top **3** onto the right side **2**.

Use a screwdriver to tighten the 2 large locking nuts **C** fitted to the right side **2**.

Note: Turn the large locking nuts **C** as far as they will go - more than 1/2 a turn.

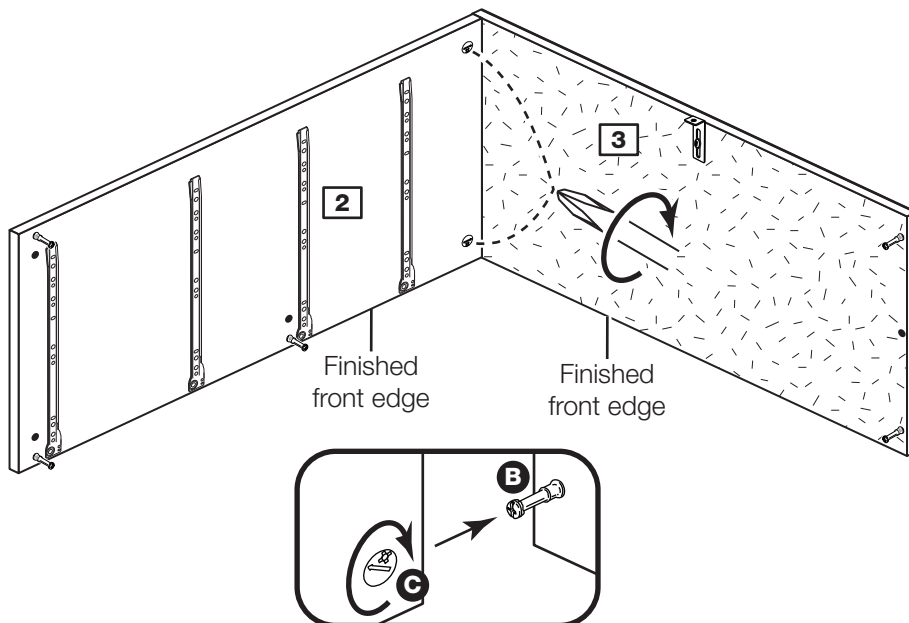

Step 21

Prepare the 3 rails

Tap 2 wooden dowels **A** into each of the 3 rails **4**.

Insert 2 large locking nuts **C** into each of the 3 rails **4**.

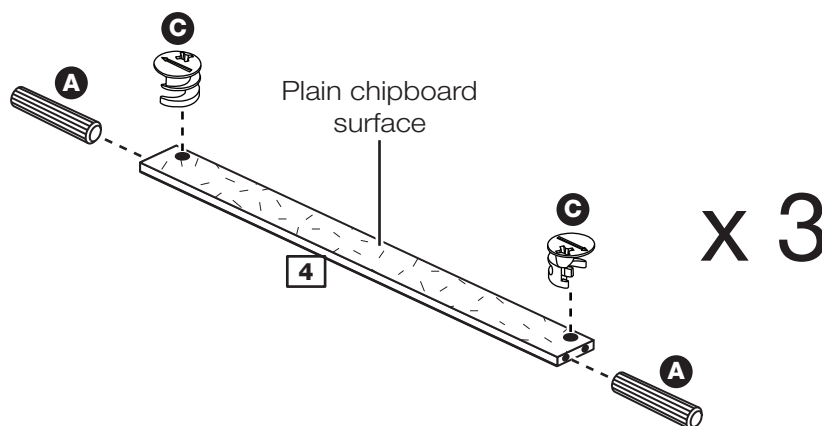

Step 22

Fit the 3 rails

Push the 3 rails **4** onto the right side **2**.

Use a screwdriver to tighten the 3 large locking nuts **C** fitted to the rails **4**.

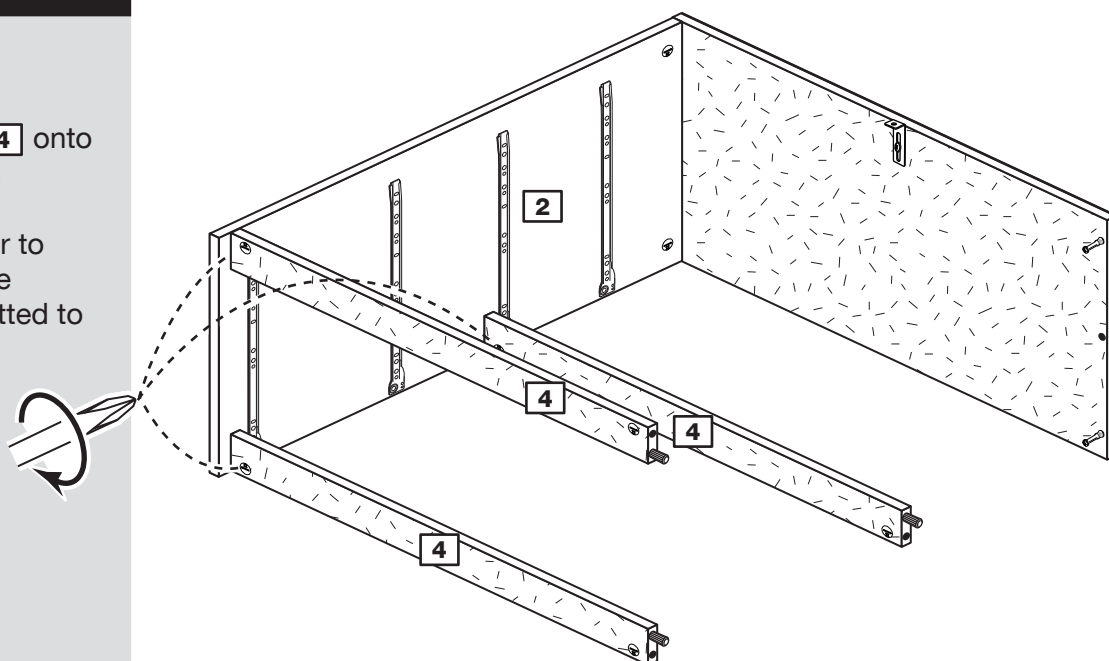

Assembly Instructions

Step 23

Fit the left side

Push the left side **1** onto the assembly.

Use a screwdriver to tighten the 5 large locking nuts **C** fitted to the left side **1** and the 3 rails **4**.

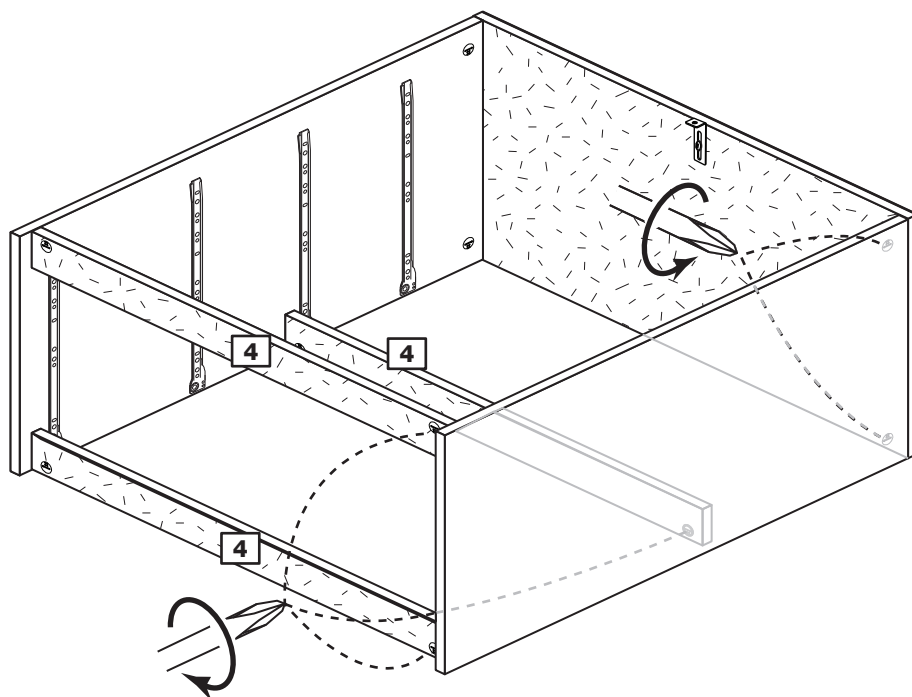

Step 24

Fit the back

a: Square up the unit by making sure that measurement **x to x** equals **y to y**.

b: Place the back **14** onto the unit.

Nail **H** around the outside edges of the back **14**.

Note: Nails should be spaced about 150mm apart.

Stand the unit up for the next step.

a: The measurement from top corner X to bottom corner X must be equal to the measurement from top corner Y to bottom corner Y

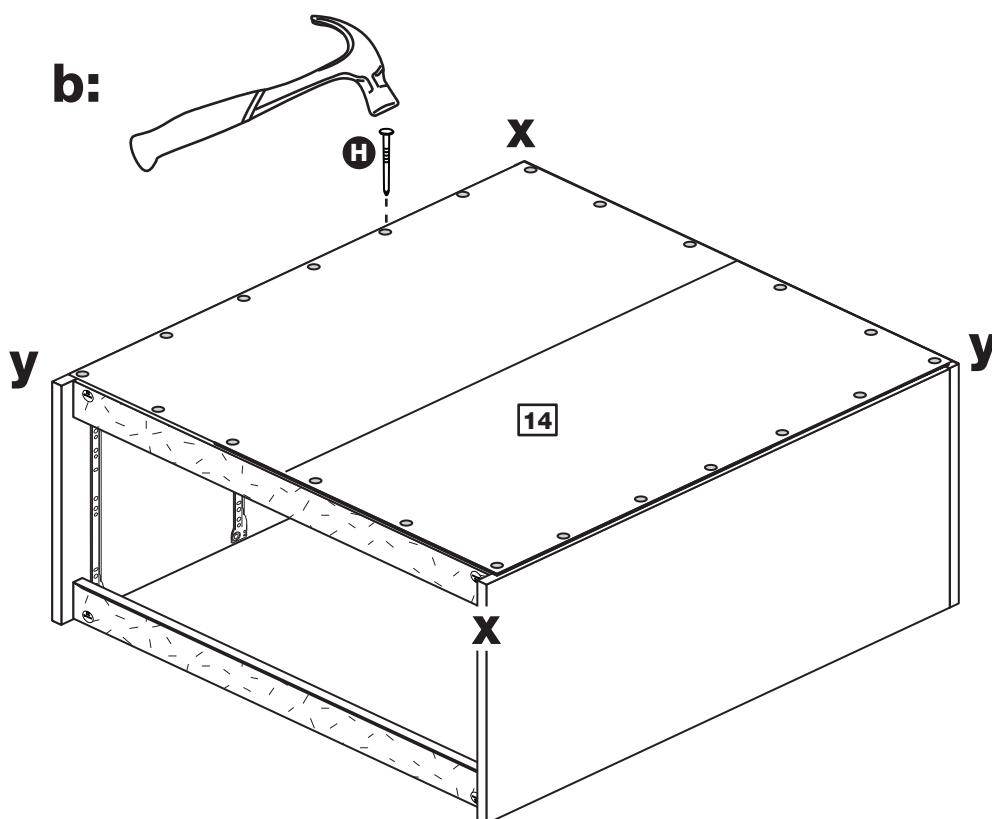

Assembly Instructions

Step 25

Fit the 4 plastic nails

Tap 2 plastic nails  into the bottom edge of each of the sides **1** and **2**.

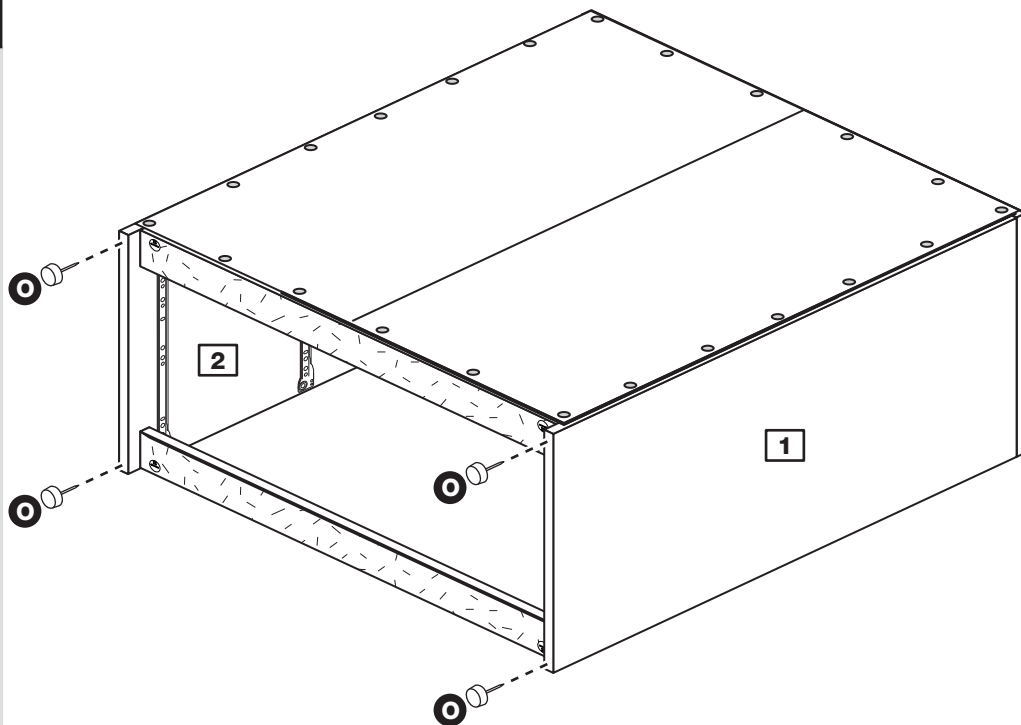

Step 26

Secure unit to a wall

To prevent possible overbalancing we recommend that this unit is secured to a suitable wall by use of the metal bracket **L** fitted under the top plinth.

Fixings are not supplied as they will need to suit the wall type, and the length of screw will depend on the distance of the back of the unit to the wall.



Warning: Take care when drilling the wall that you do not drill into any pipes, wires etc. If in doubt, consult an expert.

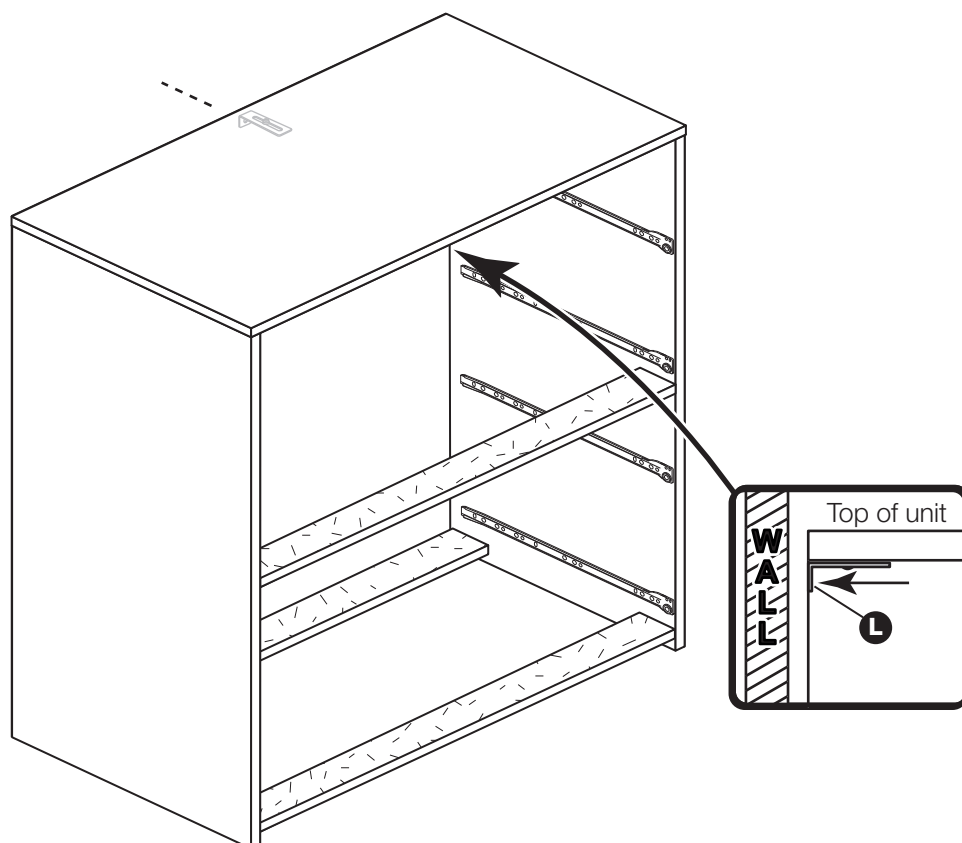

Assembly Instructions

Step 27

Fit the drawers

Slide the wheels of the runners fitted to the drawers, over the wheels of the runners fitted to the side panels and push the drawers into position.

Assembly is complete

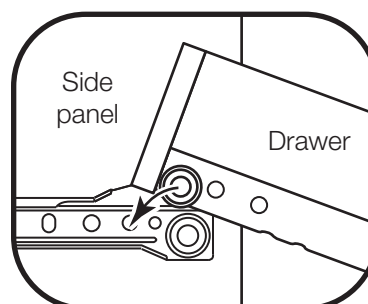
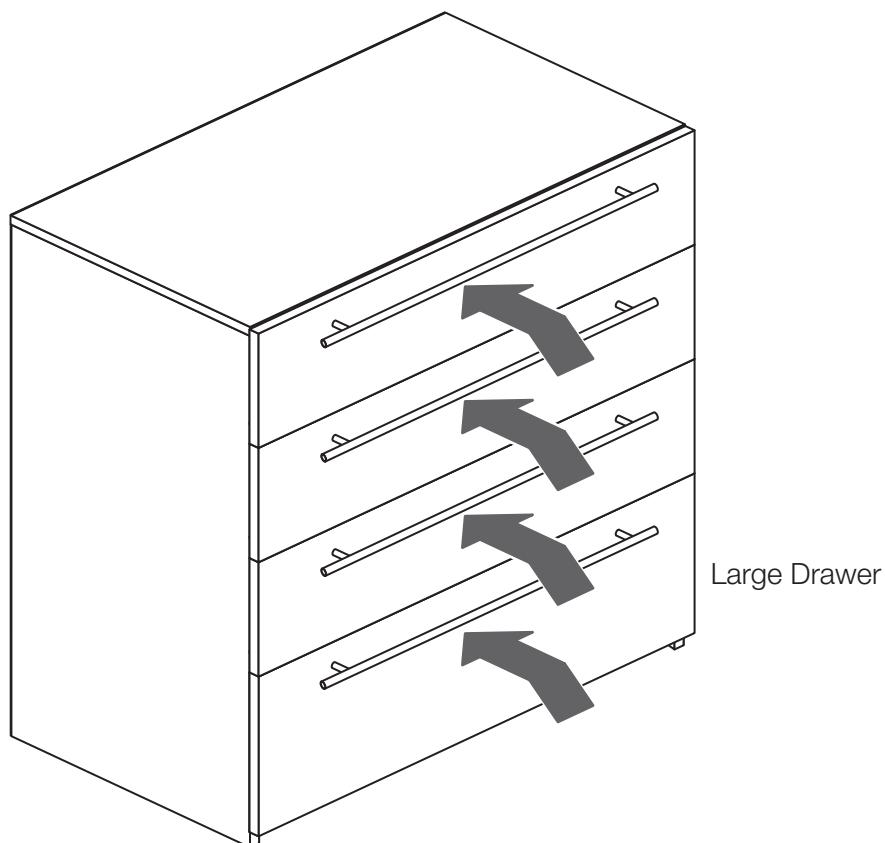

If you need help or have damaged or missing parts, call the **Customer Helpline: 08456 400800** and quote the reference numbers on the component pages.

Argos Ltd, 489-499 Avebury Boulevard, Central Milton Keynes, MK9 2NW