

# Ohio Ottoman Black Coffee Table

Assembly Instructions - Please keep for future reference

143/6563

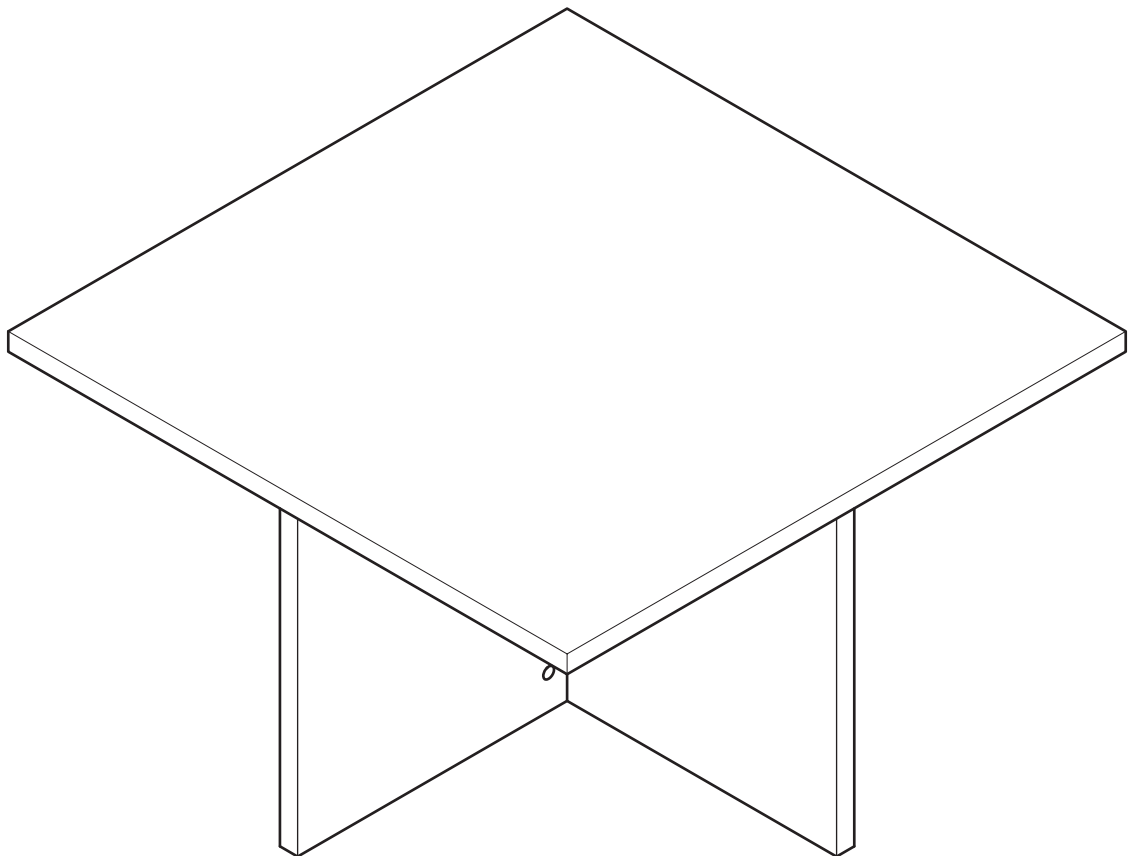

## Dimensions

Width - 79cm

Depth - 79cm

Height - 43.5cm

**Important** - Please read these instructions fully before starting assembly

If you need help or have damaged or missing parts, call the **Customer Helpline: 08456 400800**



# Safety and Care Advice

## Important - Please read these instructions fully before starting assembly

- Do not discard any of the packaging until you have checked that you have all the parts and the pack of fittings.
- Check you have all the components and tools listed on page 2.
- Remove all fittings from the plastic bags and separate them into their groups.
- Keep children and animals away from the work area, small parts could choke if swallowed.
- Make sure you have enough space to layout the parts before starting.

- Assemble the item as close to its final position (in the same room) as possible.
- Assemble on a soft level surface to avoid damaging the unit or your floor.
- Assemble this product on a flat surface.
- Assemble all parts loosely before tightening any bolts.
- Unit weight: 21.2kgs.
- At least 2 people are required to assemble this product.



- We do not recommend the use of power drill/drivers **for inserting screws**, as this could damage the unit. Only use hand screwdrivers.
- Discard all extra fittings and keep fittings out of reach of children.
- Dispose of all packaging carefully and responsibly.
- Retain Assembly Instructions for future reference.

## Warnings

- This product should only be used on firm, level ground.
- Make sure the legs remain in contact with the ground.
- Do not stand on the product.

## Care and maintenance

- Please clean this product using either damp (not wet) cloth and a mild domestic soap solution or by using an appropriate polish.
- Do not use any abrasive materials when cleaning.
- From time to time check that there are no loose bolts on this unit.
- This product should not be discarded with household waste. Take to your local authority waste disposal centre.

# Components - Parts

If you have damaged or missing components, call the **Customer Helpline: 08456 400800**

Please check you have all the parts listed below

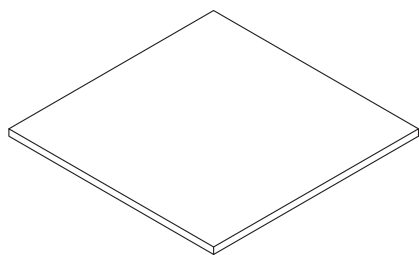

**1** Table Top  
(79 x 79 x 2.5cm)

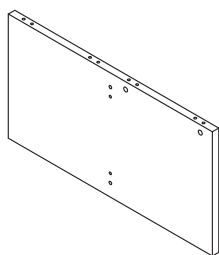

**2** Long Base Panel  
(78.5 x 40.5 X 2.5cm)

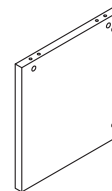





**3** Short Base Panel x 2  
(38 x 40.5 x 2.5cm)

# Components - Fittings

Please check you have all the fittings listed below

**Note:** The quantities below are the correct amount to complete the assembly. In some cases more fittings may be supplied than are required.

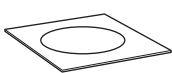
<p><b>A</b> </p> <p>Bolt x 12</p>	<p><b>B</b> </p> <p>Cam Lock x 12</p>	<p><b>C</b> </p> <p>Short Wooden Dowel x 8</p>
<p><b>D</b> </p> <p>Long Wooden Dowel x 2</p>	<p><b>E</b> </p> <p>Adhesive Pad x 12</p>	

## Tools required



Crosshead Screwdriver

**Ruler** - Use this ruler to help correctly identify the screws

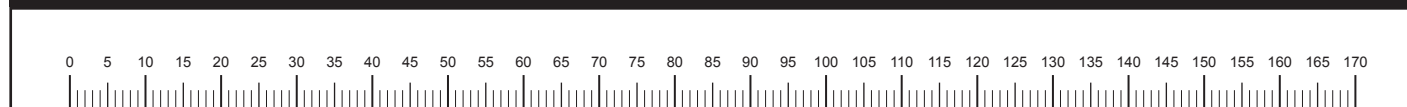

# Assembly Instructions

## Step 1

### Base panels assembly

**a:** Insert bolts **A** into holes on long base panel **2** as shown and tighten using a crosshead screwdriver.

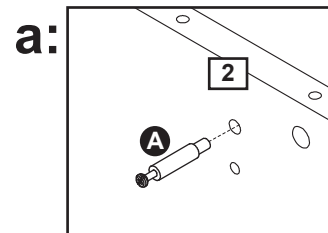
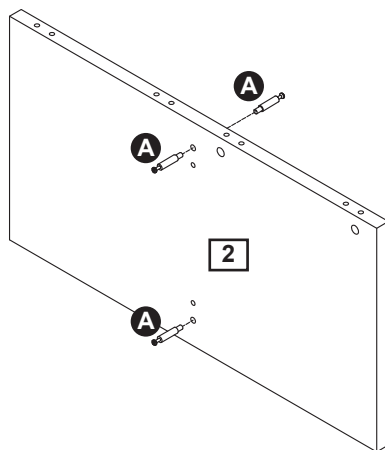

**b:** Insert long wooden dowels **D** into holes on short base panels **3**.

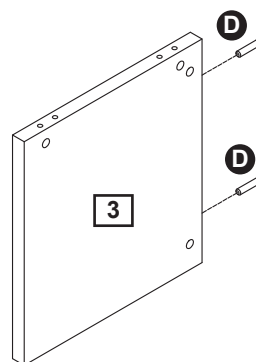
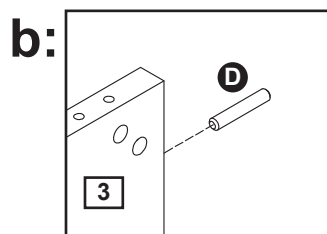

**c:** Insert cam locks **B** into holes on short base panels **3**.

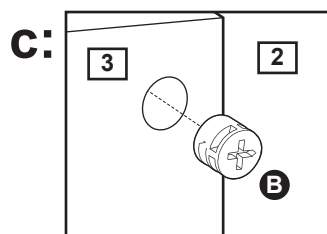

**d:** Attach the short base panels **3** to long base panel **2** aligning the dowels and bolts with the cam locks as shown.

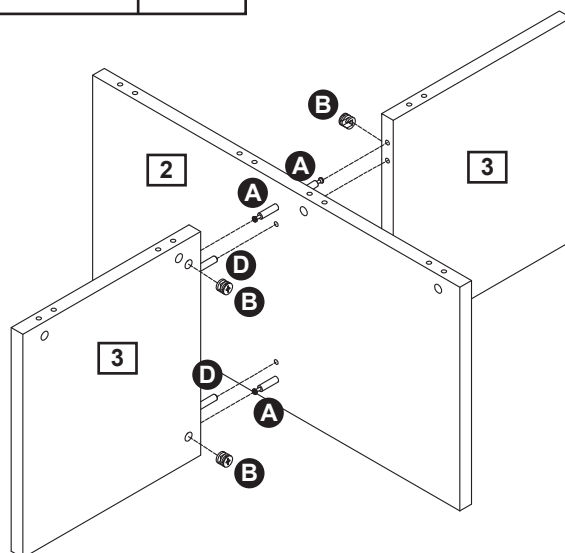

**d:**

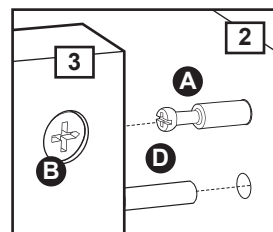

**e:** Then lock using a crosshead screwdriver by turning the cam locks **B** clockwise.

**e:**

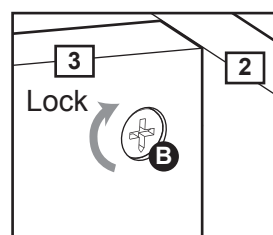

# Assembly Instructions

## Step 2

### Attaching the table top

**a:** Place the table top **1** upside down on a flat protected surface.

Insert bolts **A** into holes on the table top **1** as shown and tighten using a crosshead screwdriver.

**b:** Insert short wooden dowels **C** into holes on long & short base panels **2** & **3**.

**c:** Insert cam locks **B** into holes on long & short base panels **2** & **3**.

**d:** Attach the table top **1** onto the base panels aligning the dowels and bolts with the cam locks as shown.

**e:** Then lock using a crosshead screwdriver by turning the cam locks **B** clockwise.

**f:** Remove backing from adhesive pads **E** and paste it on the base panels **2** & **3** to cover the cam locks.

Carefully turn over the table and place on a flat surface.

**Assembly is complete.**

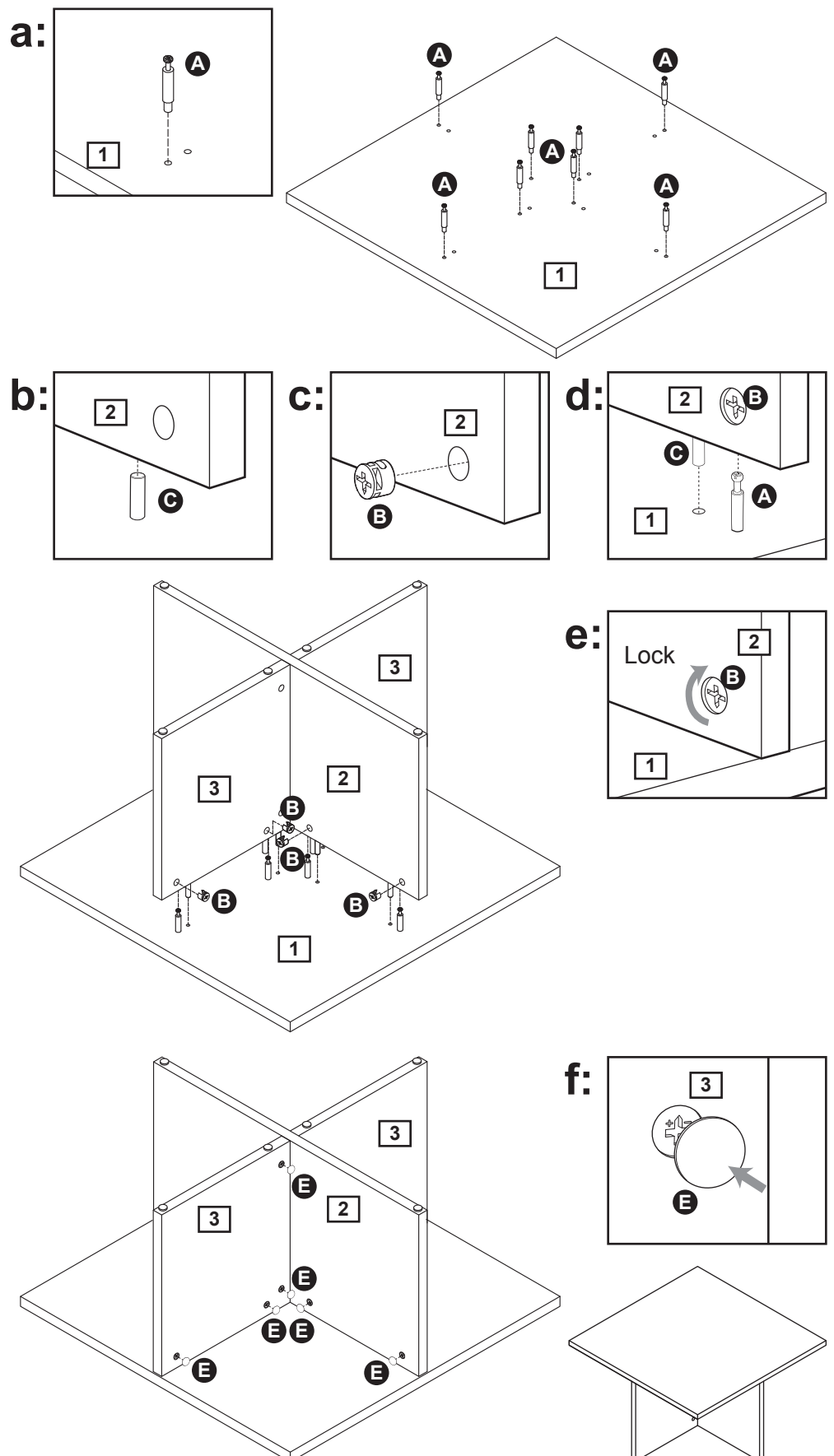

If you need help or have damaged or missing parts, call the **Customer Helpline: 08456 400800**

# Ohio Ottoman Coffee Table- Ottoman

Assembly Instructions - Please keep for future reference

143/6563

173/6029

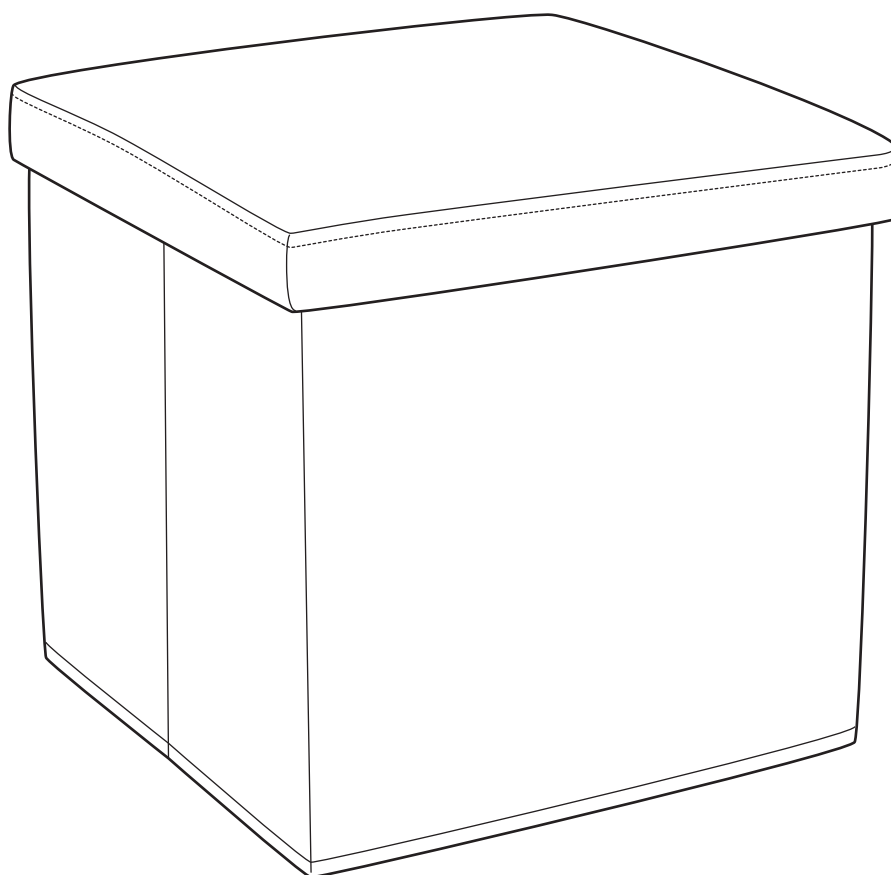

## Dimensions

Width - 39cm

Depth - 39cm

Height - 37.5cm

**Important - Please read these instructions fully before starting assembly**

If you need help or have damaged or missing parts, call the **Customer Helpline: 08456 400800**



# Safety and Care Advice

## Important - Please read these instructions fully before starting assembly

- Do not discard any of the packaging until you have checked that you have all the parts.
- Check you have all the components listed on page 2.
- Remove all components from the plastic bags and separate them into their groups.
- Keep children and animals away from the work area, small parts could choke if swallowed.
- Make sure you have enough space to layout the parts before starting.
- Assemble the item as close to its final position (in the same room) as possible.
- Assemble on a soft level surface to avoid damaging the unit or your floor.
- Assemble this product on a flat surface.
- Unit weight: 2.94kgs.
- Maximum safe weight of user: 110kgs.
- Dispose of all packaging carefully and responsibly.
- Retain Assembly Instructions for future reference.

## Warnings

- This product should only be used on firm, level ground.
- Make sure the base remain in contact with the ground.
- Do not stand on the product.

## Care and maintenance

- Please clean this product using either damp (not wet) cloth and a mild domestic soap solution or by using an appropriate polish.
- Do not use any abrasive materials when cleaning.
- This product should not be discarded with household waste. Take to your local authority waste disposal centre.

# Components - Parts

If you have damaged or missing components,  
call the **Customer Helpline: 08456 400800**

Please check you have all the parts listed below

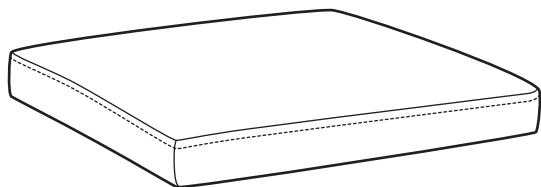

**1** Top cover  
(39 x 39 x 5cm)

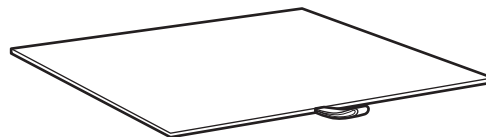

**2** Bottom panel  
(35.5 x 36cm)

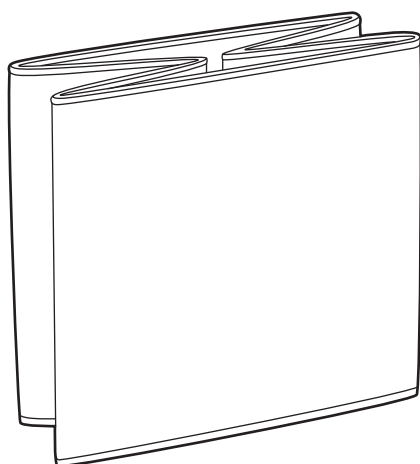

**3** Seat frame  
(36 x 36 x 36cm)



# Assembly Instructions

## Step 1

### Opening seat frame

Open the folded seat frame **3** by pulling from the side edge as shown.

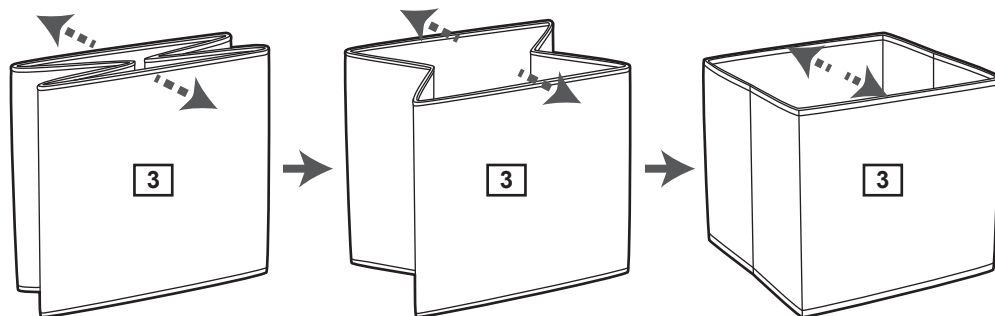

## Step 2

### Attaching bottom panel

Use the handle on the bottom panel **2** to hold it, then insert it inside the seat frame **3** and carefully push it down into the bottom as shown.

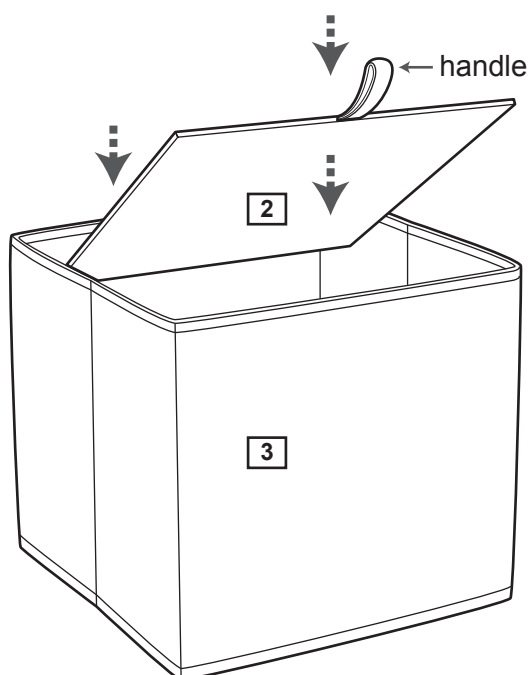

## Step 3

### Attaching top cover

Carefully fit top cover **1** on the seat frame **3** as shown.

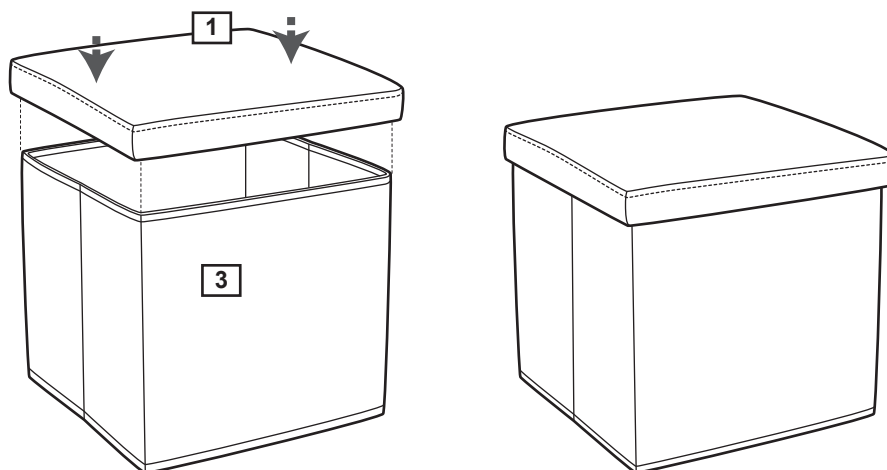

**Assembly is complete.**

If you need help or have damaged or missing parts, call the **Customer Helpline: 08456 400800**