

Constable Oak Extension Dining Table

Assembly Instructions - Please keep for future reference

176/0325

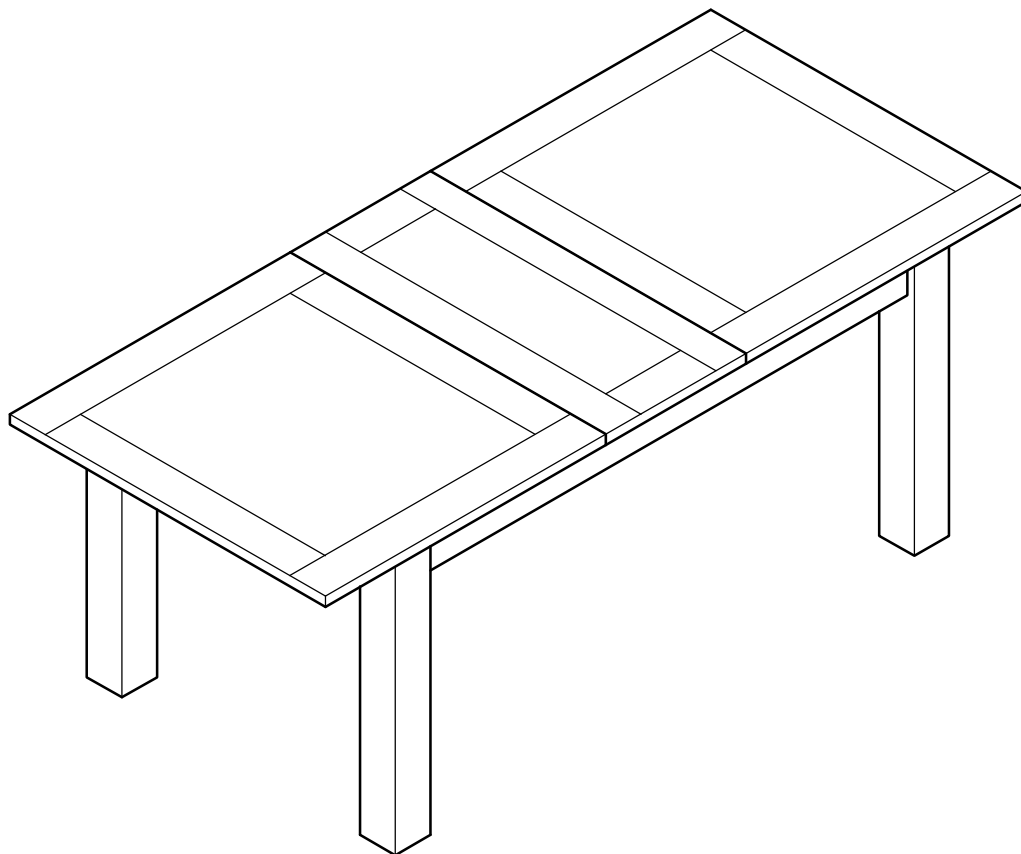

Dimensions

Width - 160/ 200cm

Depth - 90cm

Height - 75cm

Important - Please read these instructions fully before starting assembly.

If you need help or have damaged or missing parts, call the **Customer Helpline: 08456 400800**



Safety and Care Advice

Important - Please read these instructions fully before starting assembly.

- Check you have all the components and tools listed on page 2.

- Remove all fittings from the plastic bags and separate them into their groups.

- Keep children and animals away from the work area, small parts could choke if swallowed.

- Make sure you have enough space to layout the parts before starting.

- Do not stand or put weight on the product, this could cause damage.

- Assemble the item as close to its final position (in the same room) as possible.

- Assemble on a soft flat / firm surface to avoid damaging the unit or your floor.

- Parts of the assembly will be easier with 2 people.



- We do not recommend the use of power drill/ drivers **for inserting screws**, as this could damage the unit. Only use hand screwdrivers.

- Dispose of all packaging carefully and responsibly .

Care and maintenance

- Only clean using a damp cloth and mild detergent, do not use bleach or abrasive cleaners.

- From time to time check that there are no loose screws on this unit.

- This product should not be discarded with household waste. Take to your local authority waste disposal centre.

Components-Table tops & Legs

If you have damaged or missing components, call the **Customer Helpline: 08456 400800**

Please check you have all the panels listed below.



1 Legs x 4
(10 x 72.2cm)

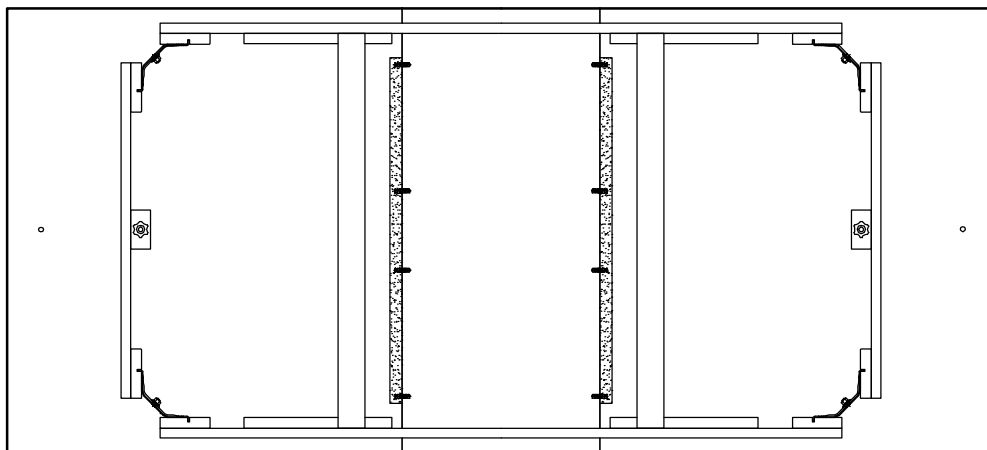

2 Table top (160/200 x 90cm)







3 Extension leaf (90 x 40cm)

Components - Fittings

Please check you have all the fittings listed below.

Note: The quantities below are the correct amount to complete the assembly. In some cases more fittings may be supplied than are required.

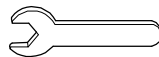
| | | |
|---|---|--|
| <p>A </p> <p>60mm Cross dowel x 4</p> | <p>B </p> <p>70mm Threaded bolt x 8</p> | <p>C </p> <p>Flat washer x 8</p> |
| <p>D </p> <p>Lock washer x 8</p> | <p>E </p> <p>Hex nut x 8</p> | <p>F </p> <p>Spanner x 1</p> |

Ruler - Use this ruler to help correctly identify the screws

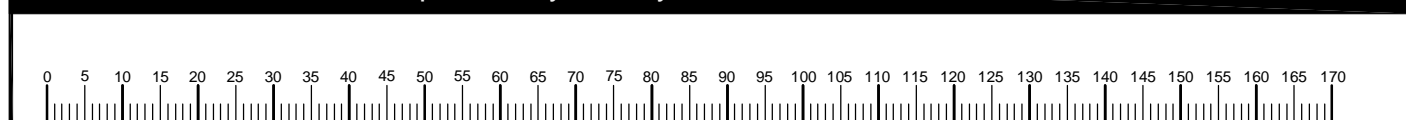

Assembly Instructions

Step 1

Fitting dowels

a: Insert cross dowels **A** into the holes on top of legs **1**.

Note: Ensure the horizontal marking on each cross dowel is facing out as shown.

a:

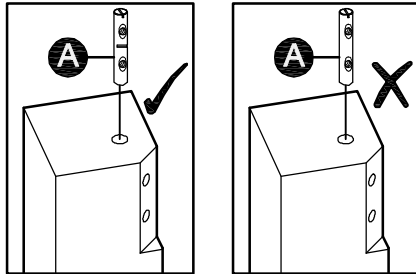

b: Insert 2 threaded bolts **B** into the two holes on all legs **1**.

Tighten threaded bolts **B** into the holes of cross dowels **A** that are already concealed in legs **1** as shown.

b:

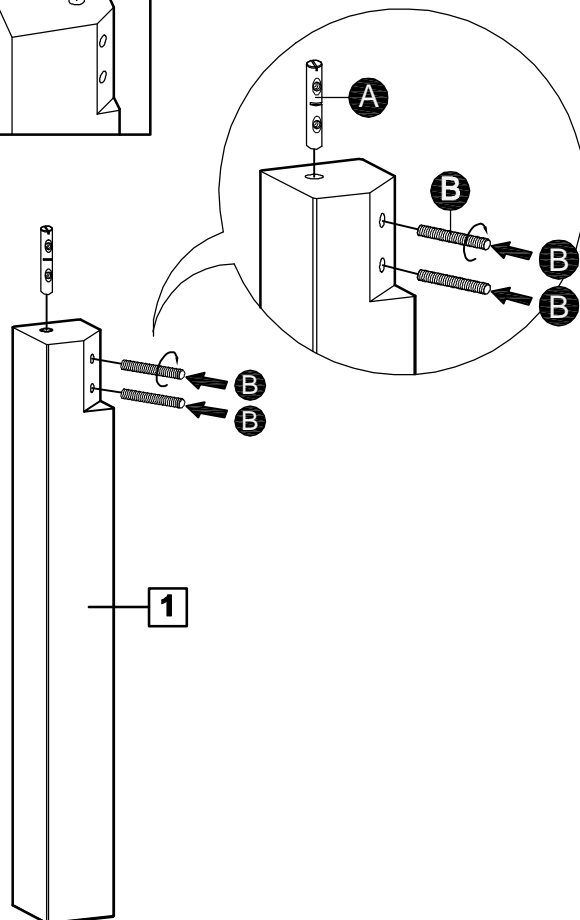

Step 2

Attaching legs

a: Lay table top **2** on a flat, stable, clean and soft surface.

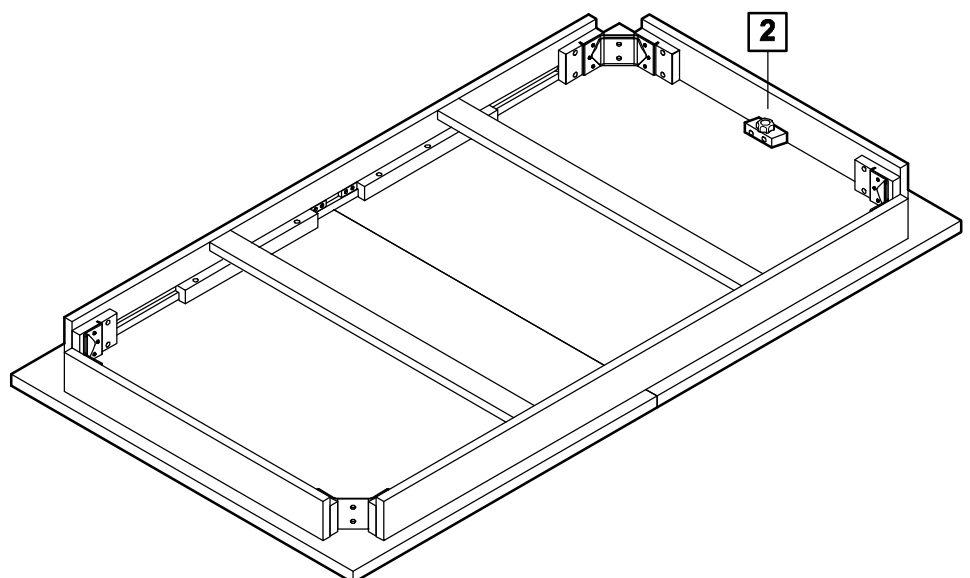

Continued on next page.

Assembly Instructions

Step 2 - continued

Attaching legs

b: Attach leg **1** onto table top **2** by inserting bolts **B** into the pre-drilled holes of metal corner bracket as shown.

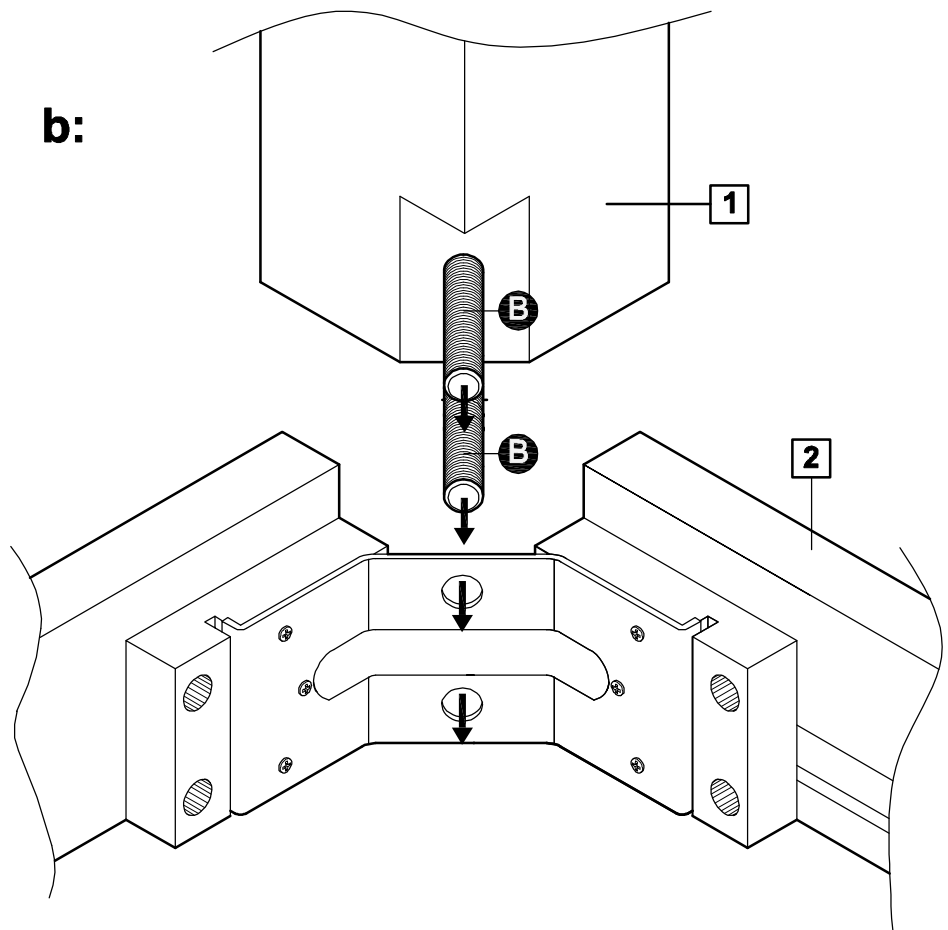

c: Insert flat washer **C**, lock washer **D** and hex nut **E** onto the two threaded bolts **B** on leg **1** and in order as shown.

C followed by **D**
D followed by **E**.

Tighten top hex nut **E** then tighten bottom hex nut **E** using spanner **F** as shown.

Note:
Do not over tighten.

Repeat steps **b:** and **c:** with the remaining 3 legs.

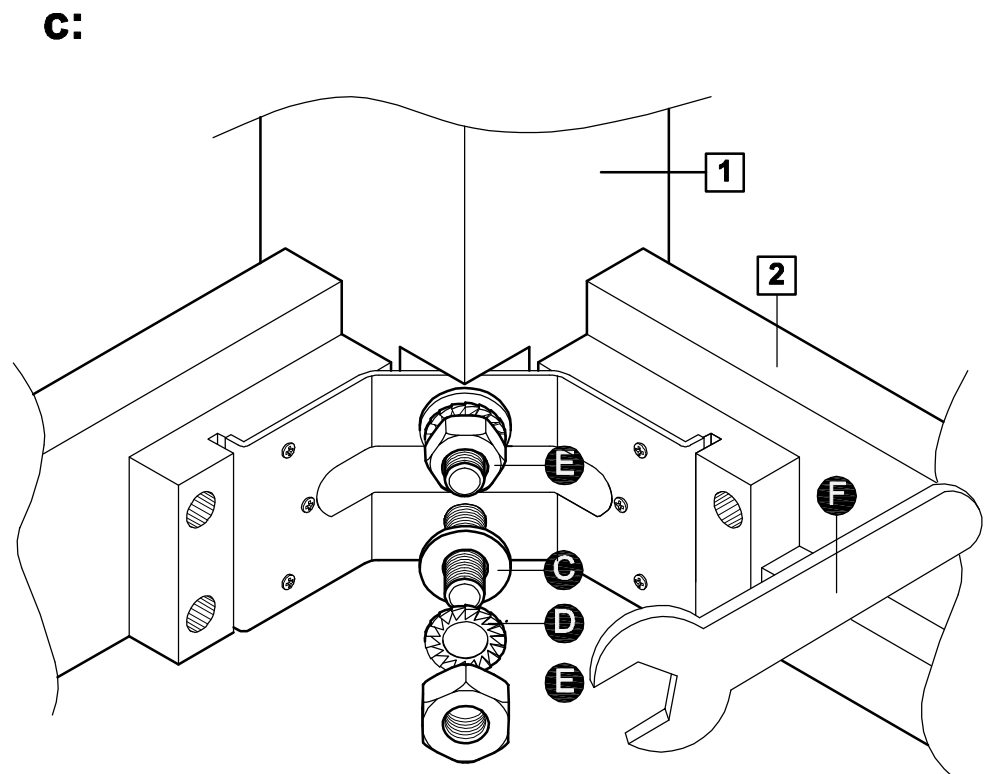

Assembly Instructions

Step 3

a: With help, carefully stand dining table upright.



Warning:

The dining table is heavy. Lift with care.

Locate thumbscrews under table ends and turn counterclockwise until clear of locking holes on underside of table top.

Extending table

b: Pull both table tops apart as shown.

c: Place extension leaf between table tops, then slide both table tops inwards until no gap is visible.

Note: Make sure metal dowels line up with holes on mating panel to avoid damage.

Turn thumbscrews on both ends of table clockwise to lock table top in place.

Continued on next page.

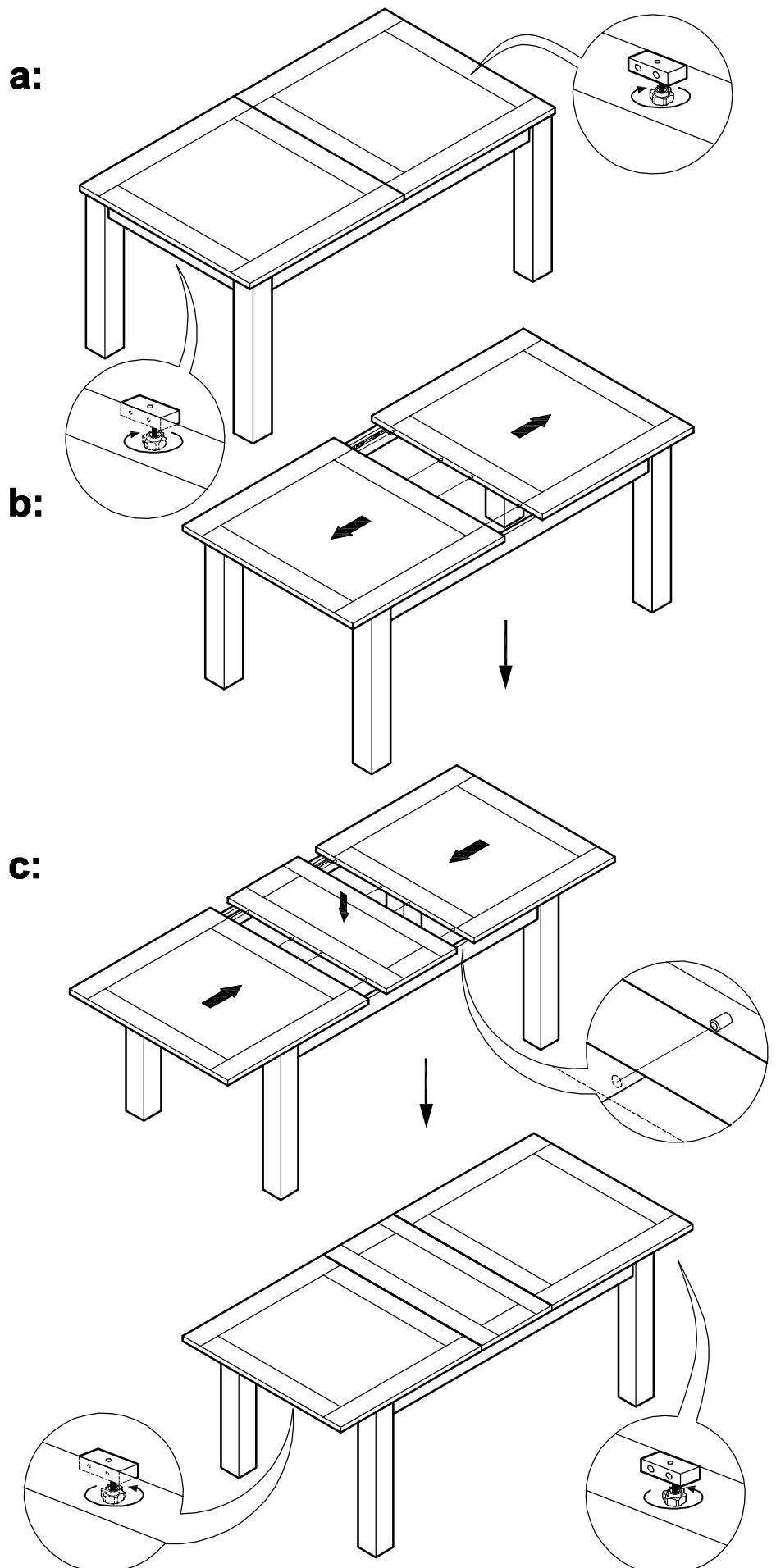

Assembly Instructions

Closing table

d: Locate and turn thumbscrews counterclockwise on both ends of the table until clear of locking holes on underside of table top.

Slide both table tops outwards, then lift the extension leaf up.

e: Carefully place the extension leaf onto wood supports under the table as shown.

f: Slide both table tops inwards until no gap is visible.

Note: Make sure metal dowels line up with holes on mating panel to avoid damage.

g: Turn thumbscrews clockwise to lock table top in place.

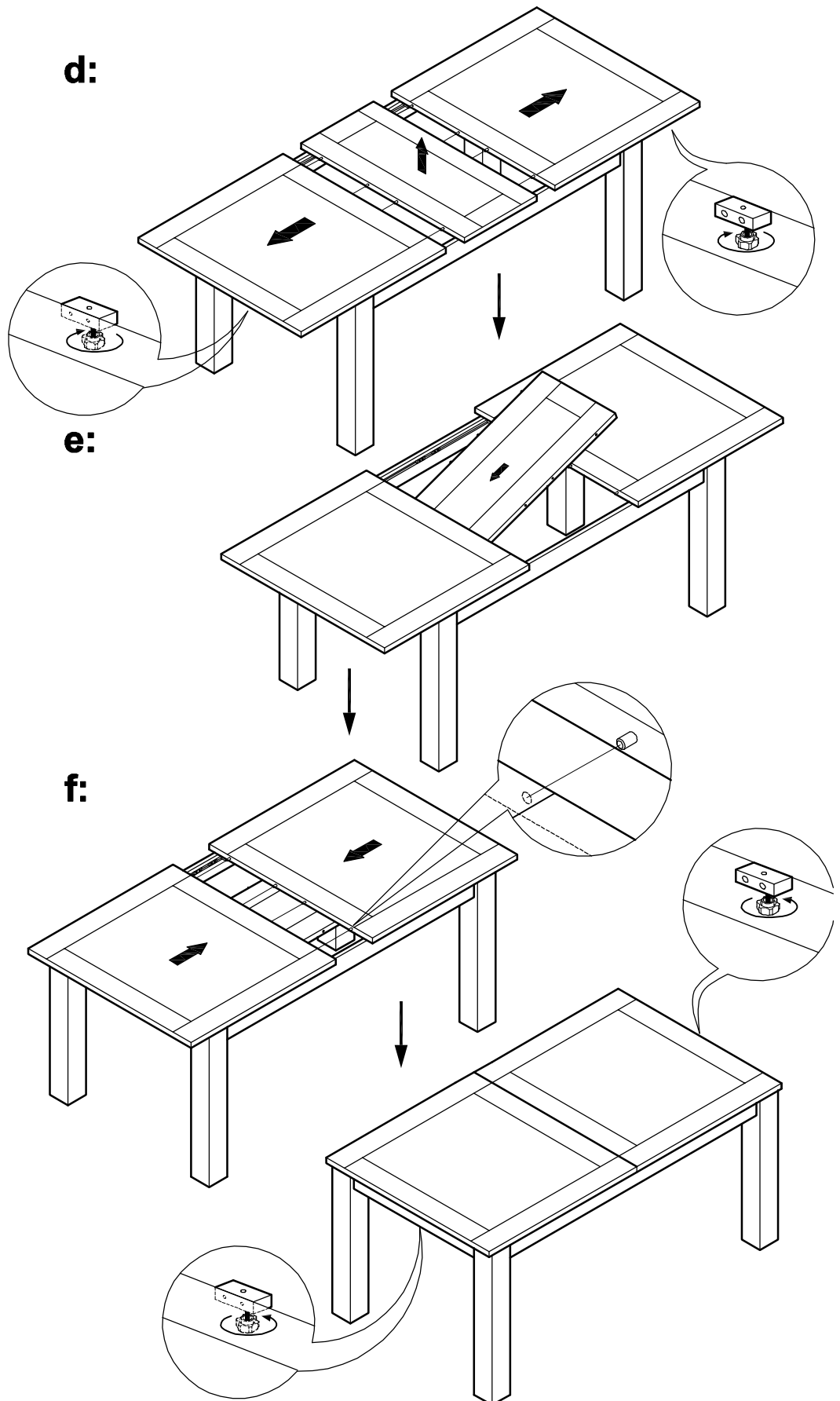

If you need help or have damaged or missing parts, call the **Customer Helpline: 08456 400800**

HAMPSHIRE PAIR OF DINING CHAIRS

Assembly Instructions - Please keep for future reference

186/4001

186/4018

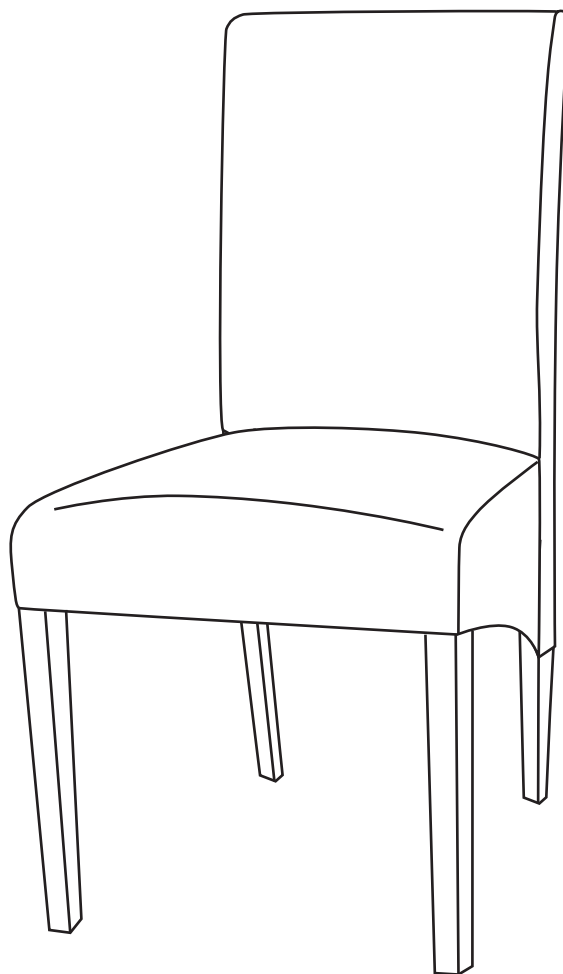

Dimensions

Width - 50cm

Depth - 67cm

Height - 106cm

Important – Please read these instructions fully before starting assembly

If you need help or have damaged or missing parts, call the Customer Helpline: 0845 640 0800



Safety and Care Advice

Important – Please read these instructions fully before starting assembly

- Check you have all the components and tools listed on pages 2 and 3.
- Remove all fittings from the plastic bags and separate them into their groups.
- Keep children and animals away from the work area, small parts could choke if swallowed.
- Make sure you have enough space to layout the parts before starting.

- Do not stand or put weight on the product during assembly, this could cause damage.
- Assemble the item as close to its final position (in the same room) as possible.
- Assemble on a soft level surface to avoid damaging the unit or your floor.
- Parts of the assembly will be easier with 2 people.



- We do not recommend the use of power drill/drivers for inserting screws as this could damage the unit. Only use hand screwdrivers.
- Dispose of all packaging carefully and responsibly.

Care and maintenance

- Only clean using a damp cloth and mild detergent, do not use bleach or abrasive cleaners.
- From time to time check that there are no loose screws on this unit.
- This product should not be discarded with household waste. Take to your local authority waste disposal centre.

Components - Panels

If you have damaged or missing components, call the **Customer Helpline: 0845 640 0800**

Please check you have all the panels listed below

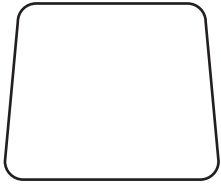

1 Seat (50 x 48cm)

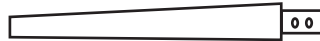

2 Leg x 2 (40 x 4.5cm)

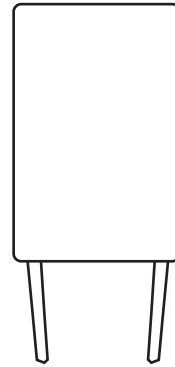



3 Back Frame (106 x 43cm)

Components - Fittings

Please check you have all the fittings listed below

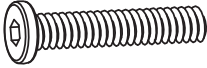
Note: The quantities below are the correct amount to complete the assembly. In some cases more fittings may be supplied than are required.

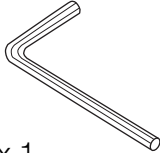
| | | |
|---|---|--|
| <p>A </p> <p>Bolt x 4 (M8 x 90mm)</p> | <p>B </p> <p>Bolt x 5 (M8 x 50mm)</p> | <p>C </p> <p>Flat washer x 9</p> |
| <p>D </p> <p>Spring washer x 9</p> | <p>E </p> <p>Hex key x 1</p> | |

Tools required

Ruler - Use this ruler to help correctly identify the screws



Assembly Instructions

Step 1

Attaching the seat to the back

Place the back **3** on a covered table top.

Remove the dust cover from seat **1**.

Place the seat on back **3** and fasten it to the back with bolts **A** and washers **B** and spring washers **D**. Please make sure **C** and **D** are assembled as shown.

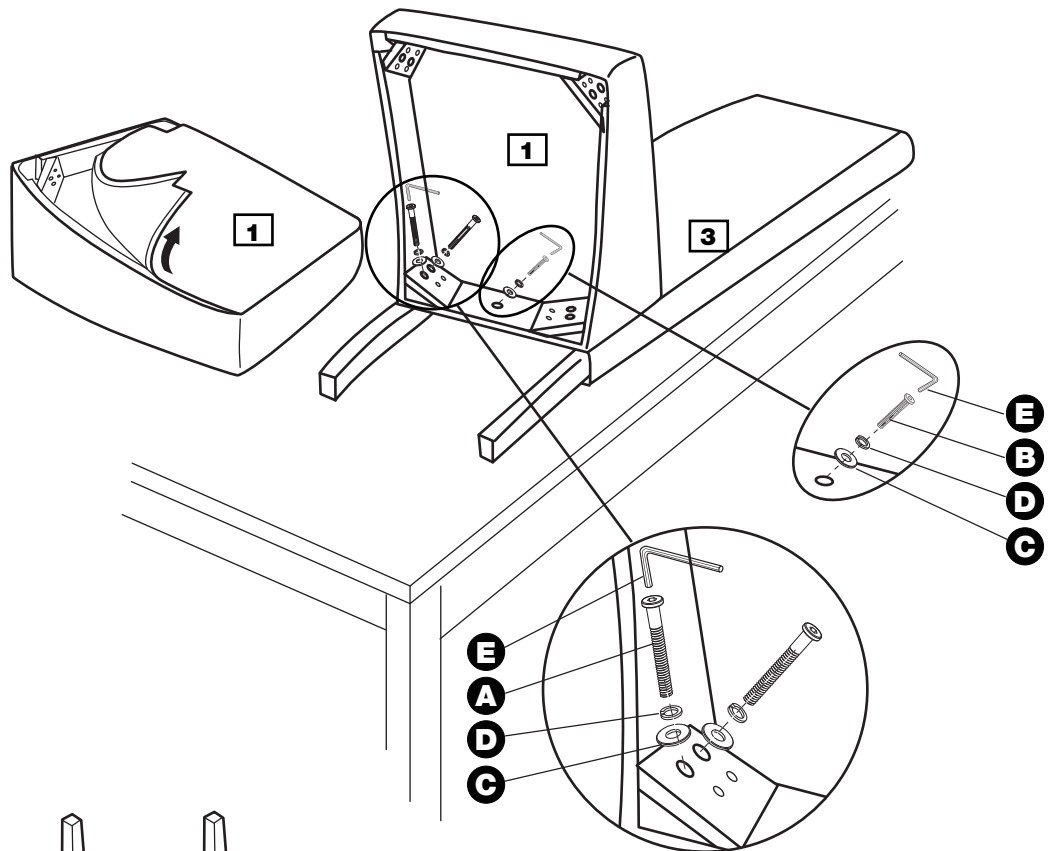

Step 2

Attaching the front legs

Insert legs **2** to the front of seat **1**.

Fasten legs **2** to seat **1** with bolts **B**, washers **C** and spring washers **D**.

Please make sure **C** and **D** are assembled as shown.

Replace the dust cover.

Carefully turn the chair over and place it on the floor.

Assembly is complete

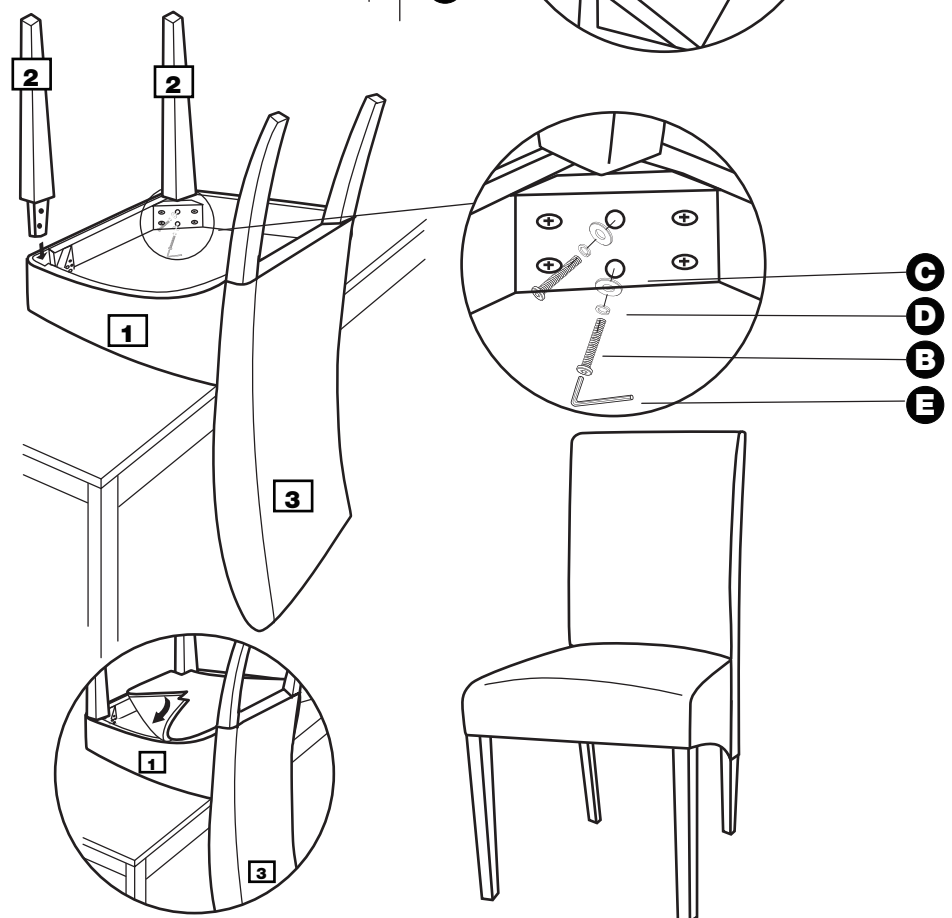

If you need help or have damaged or missing parts, call the Customer Helpline: 0845 640 0800
Argos Ltd MK9 2NW