

Emmett - Extending Dining Table

Assembly Instructions - Please keep for future reference

149/2765

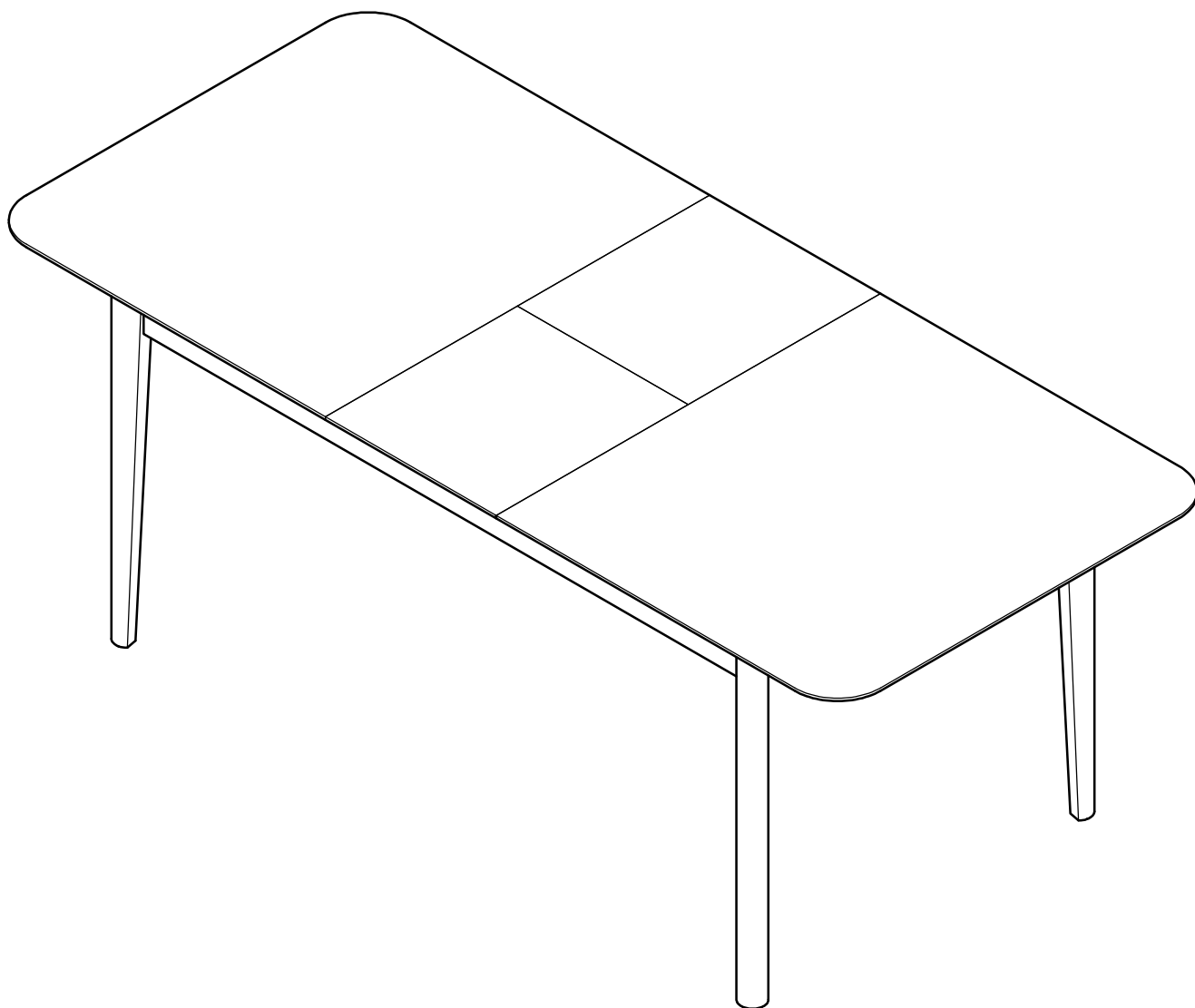

Dimensions

Width - 200cm

Depth - 90cm

Height - 75cm

Important - Please read these instructions fully before starting assembly.

If you need help or have damaged or missing parts, call the **Customer Helpline: 08456 400800**



Safety and Care Advice

Important - Please read these instructions fully before starting assembly.

- Check you have all the components and tools listed on page 2.
- Remove all fittings from the plastic bags and separate them into their groups.
- Keep children and animals away from the work area, small parts could choke if swallowed.
- Make sure you have enough space to layout the parts before starting.

- Do not stand or put weight on the product, this could cause damage.
- Assemble the item as close to its final position (in the same room) as possible.
- Assemble on a soft flat / firm surface to avoid damaging the unit or your floor.
- Parts of the assembly will be easier with 2 people.



- We do not recommend the use of power drill/ drivers **for inserting screws**, as this could damage the unit. Only use hand screwdrivers.
- Dispose of all packaging carefully and responsibly .

Care and maintenance

- Only clean using a damp cloth and mild detergent, do not use bleach or abrasive cleaners.
- From time to time check that there are no loose screws on this unit.
- This product should not be discarded with household waste. Take to your local authority waste disposal centre.

Components - Panels

If you have damaged or missing components, call the **Customer Helpline: 08456 400800**

Please check you have all the panels listed below



1 Leg x 4
(7 x 72.2cm)

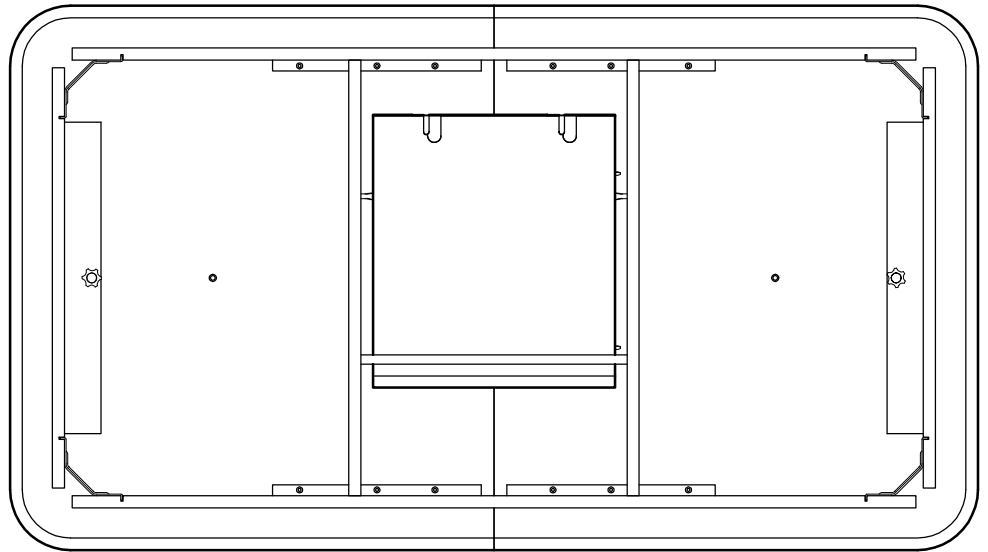





2 Top table
(160/200 x 90cm)

Components - Fittings

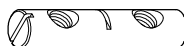
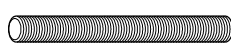
Please check you have all the fittings listed below

Note: The quantities below are the correct amount to complete the assembly. In some cases more fittings may be supplied than are required.

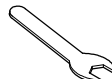
<p>A </p> <p>60mm Cross dowel x 4</p>	<p>B </p> <p>80mm Threaded bolt x 8</p>	<p>C </p> <p>Flat washer x 8</p>
<p>D </p> <p>Lock washer x 8</p>	<p>E </p> <p>Hex nut x 8</p>	<p>F </p> <p>Spanner x 1</p>

Ruler - Use this ruler to help correctly identify the screws

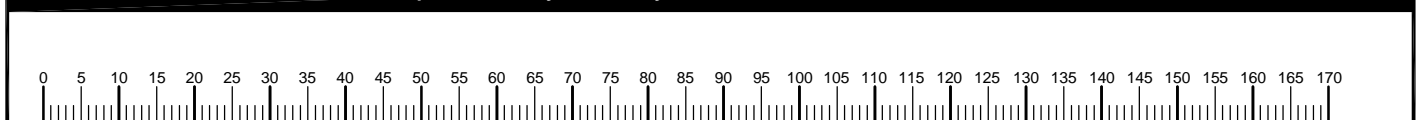

Assembly Instructions

Step 1

Fitting dowels

a: Insert cross dowel **A** into the hole on top of each leg **1**.

Note: Ensure the horizontal marking on each cross dowel is facing out as shown.

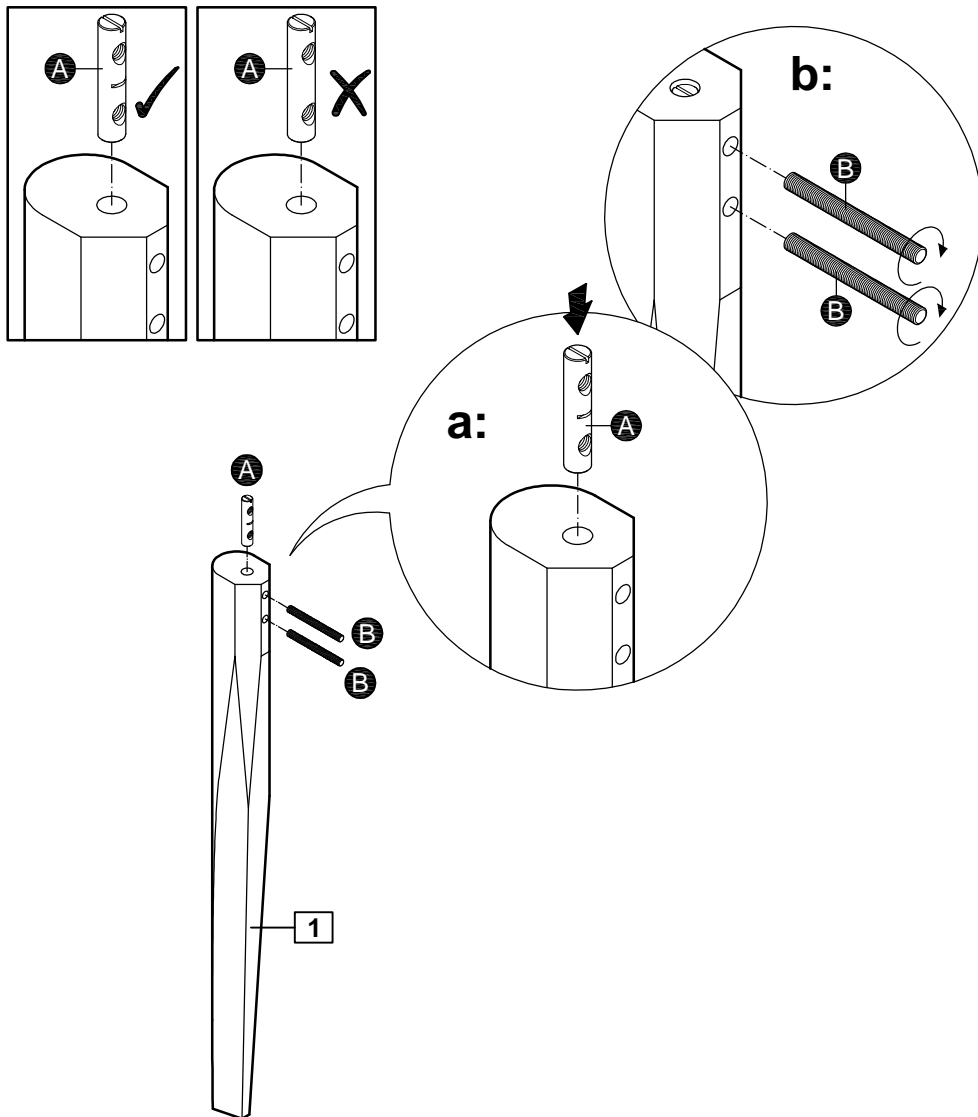

b: Insert threaded bolt **B** into the hole on each leg **1**.

Tighten threaded bolt **B** into the hole of cross dowel **A** that are already concealed in each leg **1** as shown.

Step 2

Attaching legs

a: Lay table top **2** on a flat, stable, clean and soft surface.

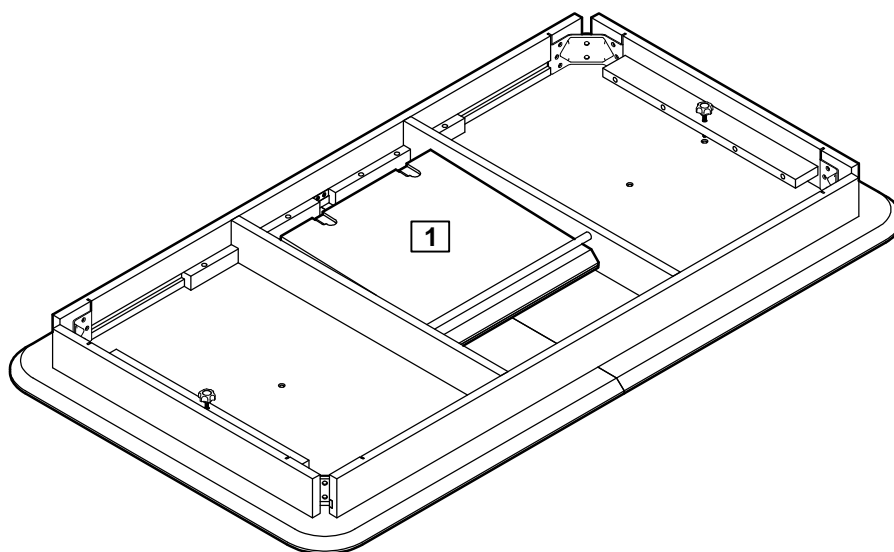

Continued on next page.

Assembly Instructions

Step 2 - continued

b: Attach leg **1** onto table top **2** by inserting bolts **B** into the pre-drilled holes of metal corner bracket as shown.

b: Insert flat washer **C**, lock washer **D** and hex nut **E** onto the two threaded bolts **B** on leg **1** and in order as shown.

C followed by **D**.
D followed by **E**.

Tighten top hex nut **E** then tighten bottom hex nut **E** using spanner **F** as shown.

Note: Do not over tighten.

Repeat Step **b** and **c** with the remaining 3 legs.

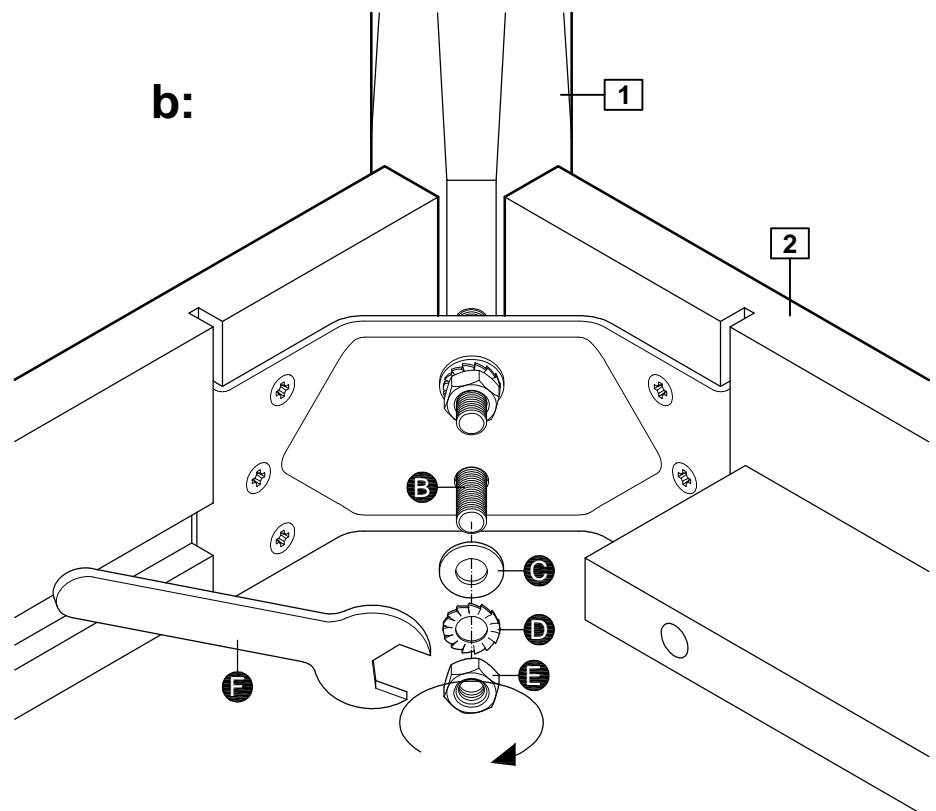
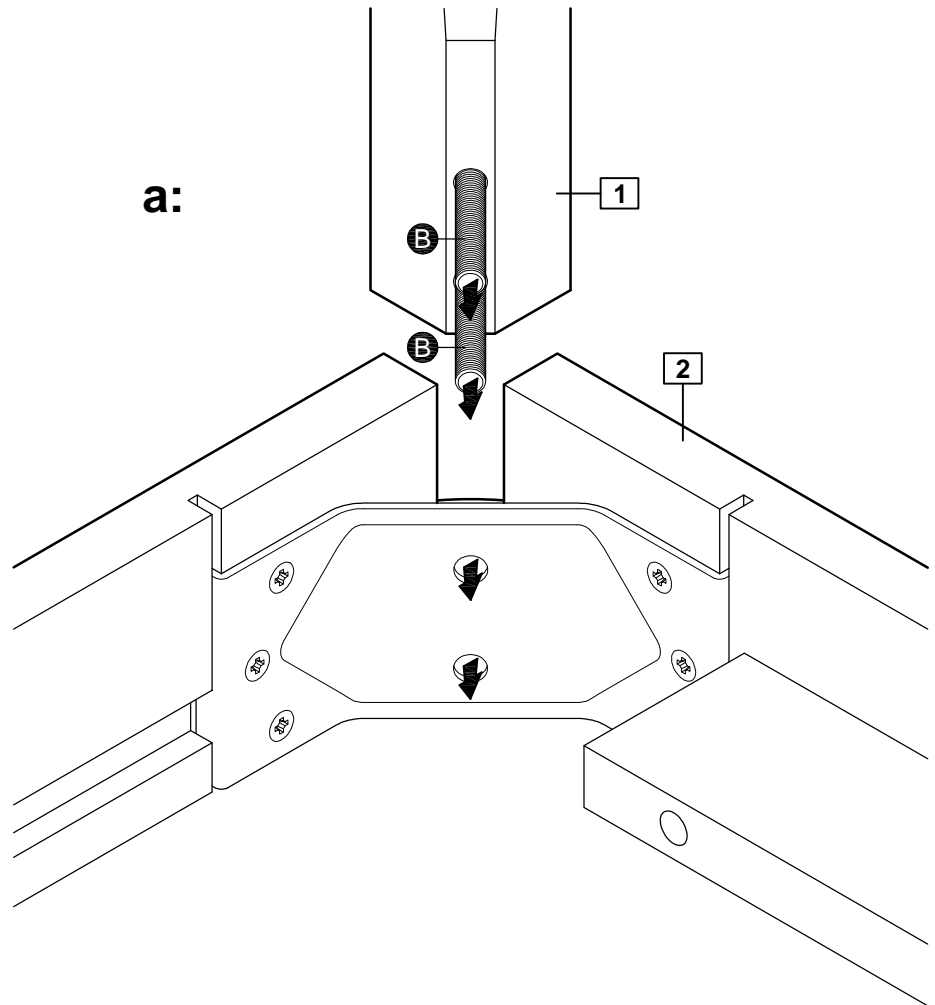

Assembly Instructions

Step 3

Stand the table upright

Turn thumbscrews clockwise to lock table top in place.

With help, carefully stand dining table upright.



Important:

LOCK table top before righting the table.



Warning:

The dining table is heavy.
Lift with care.

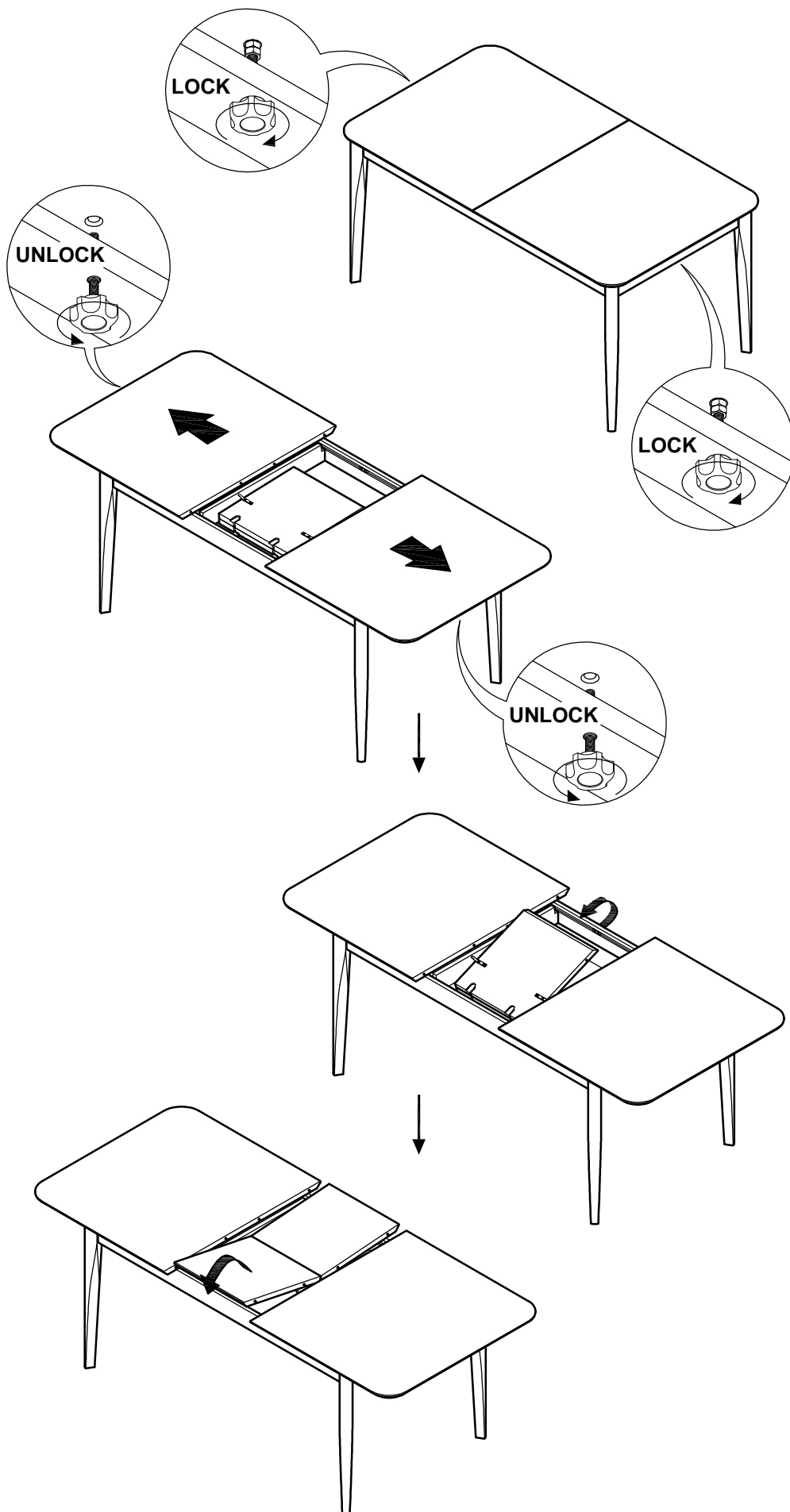

Step 4

Extending table

a: Locate thumbscrews under table ends and turn counterclockwise until clear of locking holes on underside of table top.

Pull table top apart as shown, until butterfly leaf is clearly visible underneath.



Important:

UNLOCK table top before extending the table.

Pull top piece of butterfly leaf up and lay flat as shown.

Continued on next page.

Assembly Instructions

Step 4 - continued

b: Push ends of table inwards until no gap is visible.

Note: Make sure dowels line up with holes on mating panel to avoid damage.

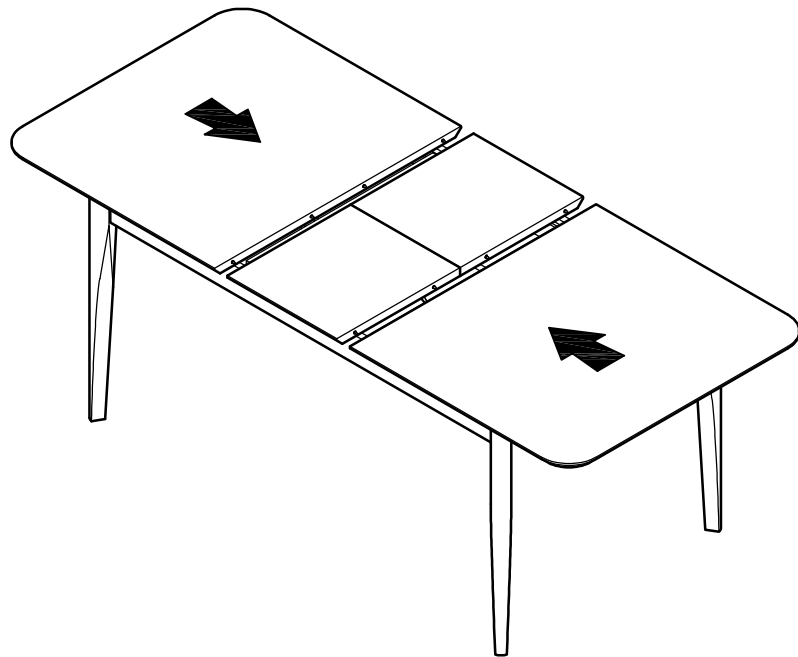

c: Turn thumbscrews clockwise to lock table top in place.

Note: To close table, reverse the procedure.

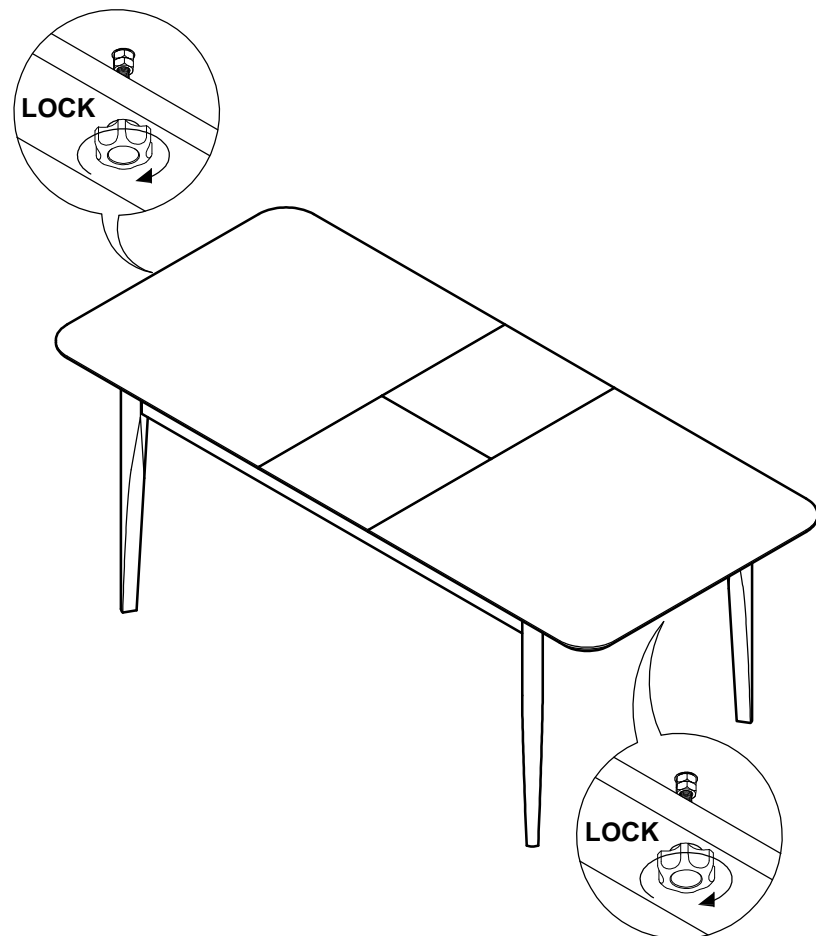

If you need help or have damaged or missing parts, call **the customer Helpline: 08456 400800**

Emmett - Pair of Upholstered Chairs

Assembly Instructions - Please keep for future reference

149/2772

149/2789

Step 3

Attaching under cloth

Place under cloth back onto seat frame **1** by lining up velcro strips and pushing firmly to fix back in place.

Stand the chair upright.

Repeat the complete process for second chair.

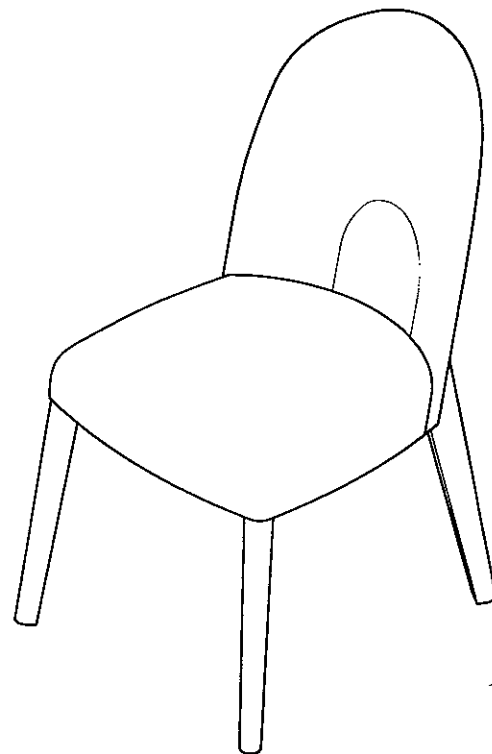
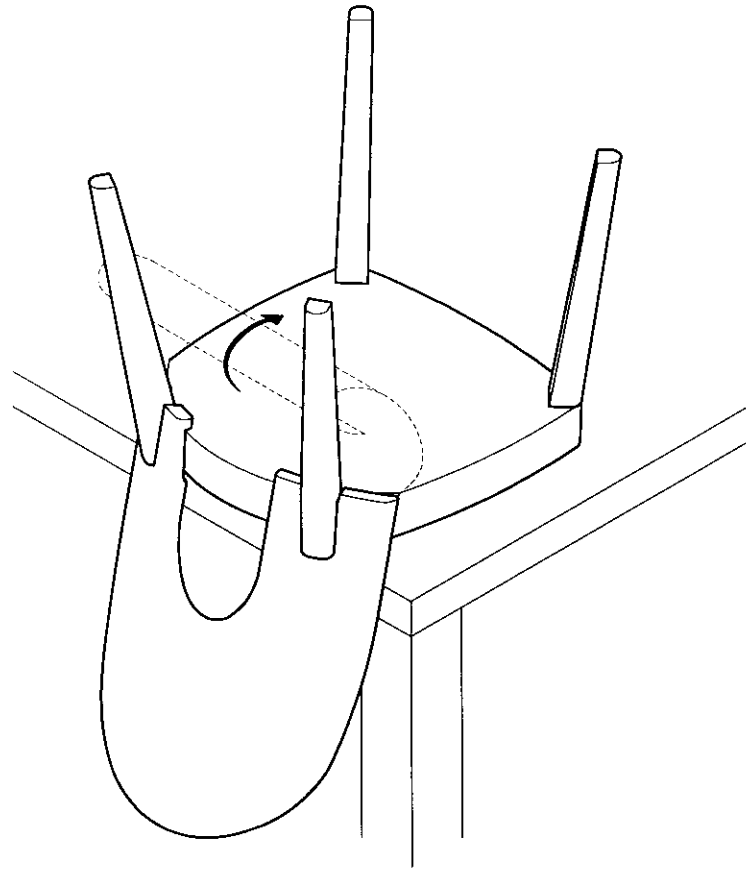

ECR # IW/4542/4546

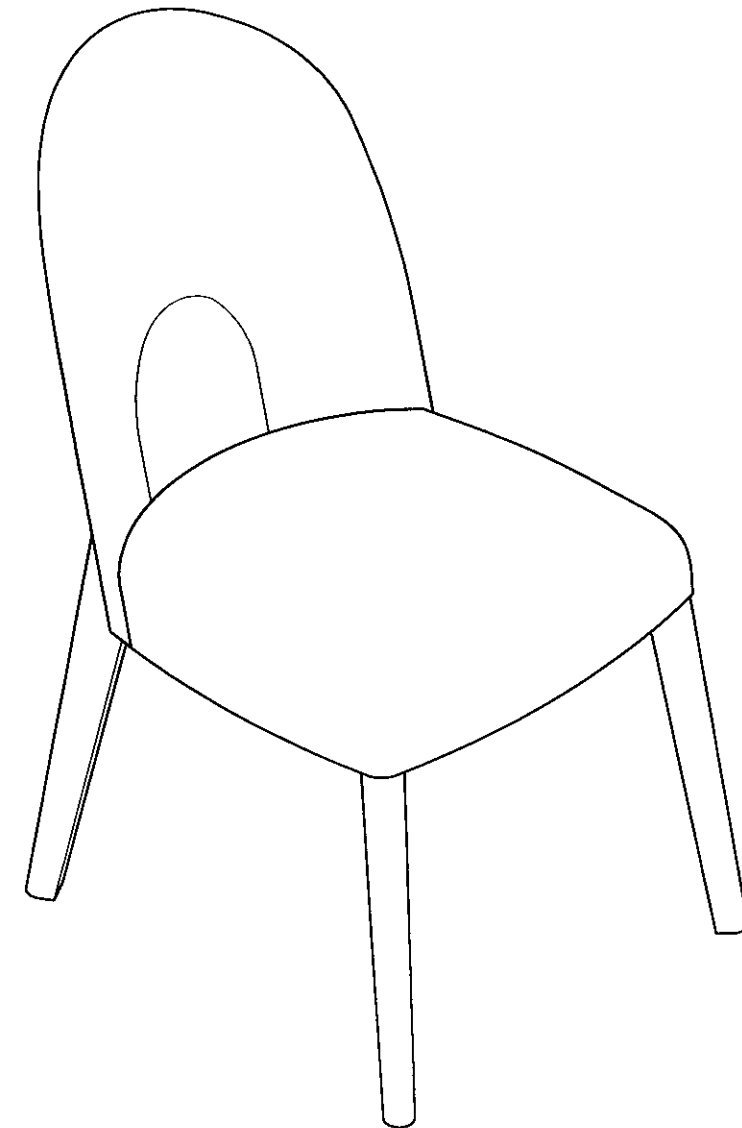

Dimensions

Width - 48cm

Depth - 62cm

Height - 87.3cm

Important - Please read these instructions fully before starting assembly.

If you need help or have damaged or missing parts, call the **Customer Helpline: 08456 400800**

Assembly is complete.

If you need help or have damaged or missing parts, call the **Customer Helpline: 08456 400800**

R
13/11/12
NB
14/11/12

⚠ Safety and Care Advice

Important - Please read these instructions fully before starting assembly.

- Check you have all the components and tools listed on page 2 and 3.

- Remove all fittings from the plastic bags and separate them into their groups.

- Keep children and animals away from the work area, small parts could choke if swallowed.

- Make sure you have enough space to layout the parts before starting.

- Do not stand or put weight on the product, this could cause damage.

- Assemble the item as close to its final position (in the same room) as possible.

- Assemble on a soft flat / firm surface to avoid damaging the unit or your floor.

- Parts of the assembly will be easier with 2 people.



- We do not recommend the use of power drill/ drivers **for inserting screws**, as this could damage the unit. Only use hand screwdrivers.

- Dispose of all packaging carefully and responsibly.

Care and maintenance

- Only clean using a damp cloth and mild detergent, do not use bleach or abrasive cleaners.

- From time to time check that there are no loose screws on this unit.

- This product should not be discarded with household waste. Take to your local authority waste disposal centre.

Note: if required the next page can be cut out and used as reference throughout the assembly. Keep this page with these instructions for future reference.

Step 2 - continued

c: Insert threaded bolts **D** through the pre-drilled hole of metal corner brackets into front legs **2** as shown.

Note: Ensure bolts **D** are aligned correctly with the fittings inside front legs **2** to avoid damage.

Screw threaded bolts **D** into the fittings **H** that are already concealed in front legs **2** as shown.

d: Insert flat washers **E**, lock washers **F** and hex nut **G** onto threaded bolts **D** on front legs and in order as shown. **E** followed by **F**, **F** followed by **G**.

Tighten hex nut **G** using spanner **C** as shown.



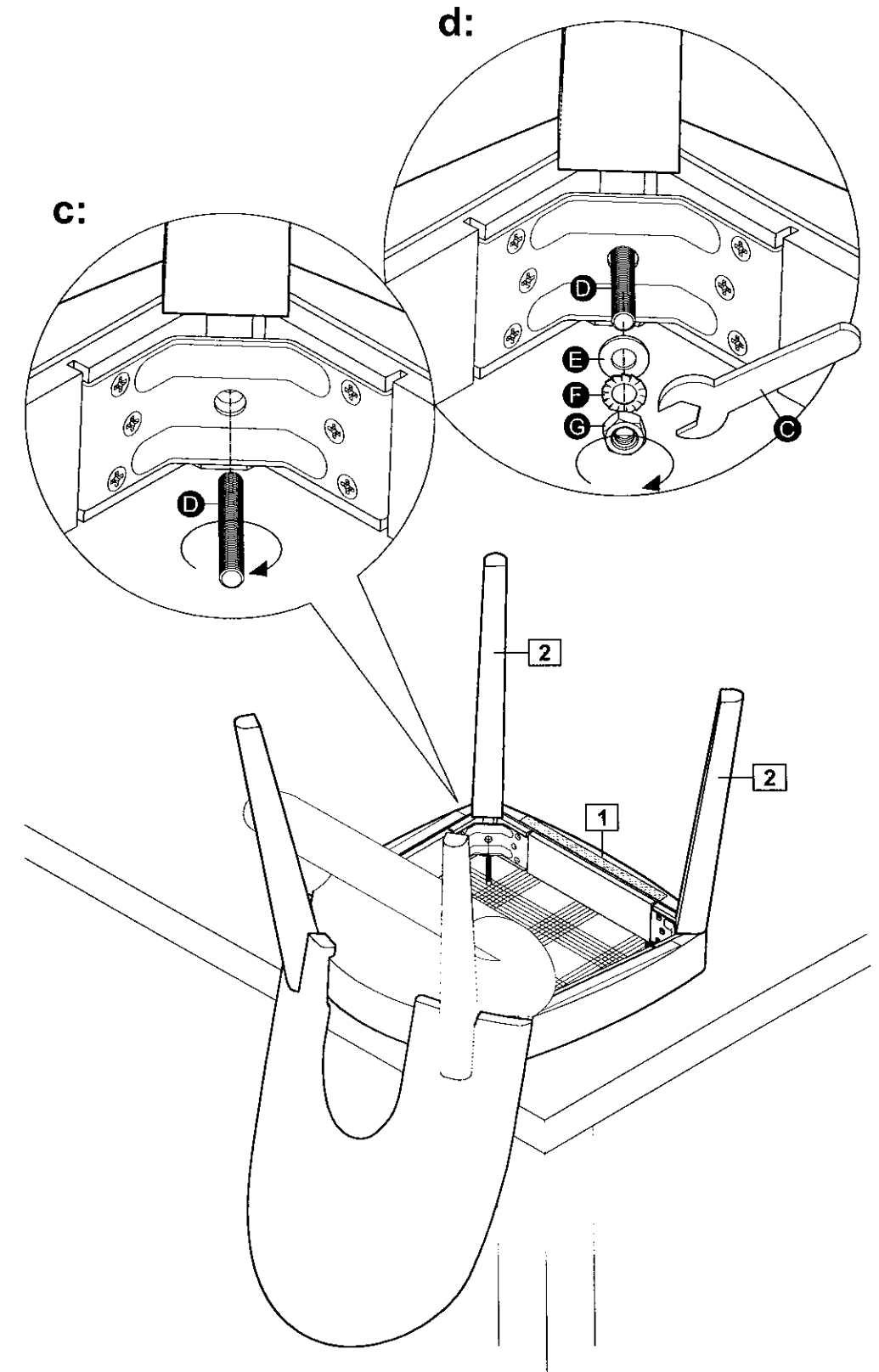





Do not over tighten.

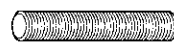

Components - Fittings

Please check you have all the fittings listed below

Note: The quantities below are the correct amount to complete the assembly. In some cases more fittings may be supplied than are required.

A  Allen key x 1	B  65mm Hex head bolt x 8	C  Spanner x 1
D  50mm Threaded bolt x 4	E  Flat washer x 12	F  Lock washer x 12
G  Hex nut x 4	H  Cross dowel x 4	J  Trim cap plastic x 4

Assembly Instructions

Step 1

Attaching back legs

a: Place chair upside down onto a flat, stable, clean and soft surface as shown.

Lift under cloth up and lay back as shown.

b: Insert lock washer **F** and flat washer **E** onto each bolt **B** as shown.

Insert bolts **B** with lock washers **F** and flat washers **E** through the pre-drilled holes of seat frame **1** into back legs **3** and **4** as shown.

Note: Ensure bolts **B** are aligned correctly with the fittings inside legs **3** and **4** before attaching.

Tighten bolts **B** into the fittings inside back legs **3** and **4** as shown.

Use allen key **A** to turn fittings **B** clockwise to fix.

Do not over tighten.

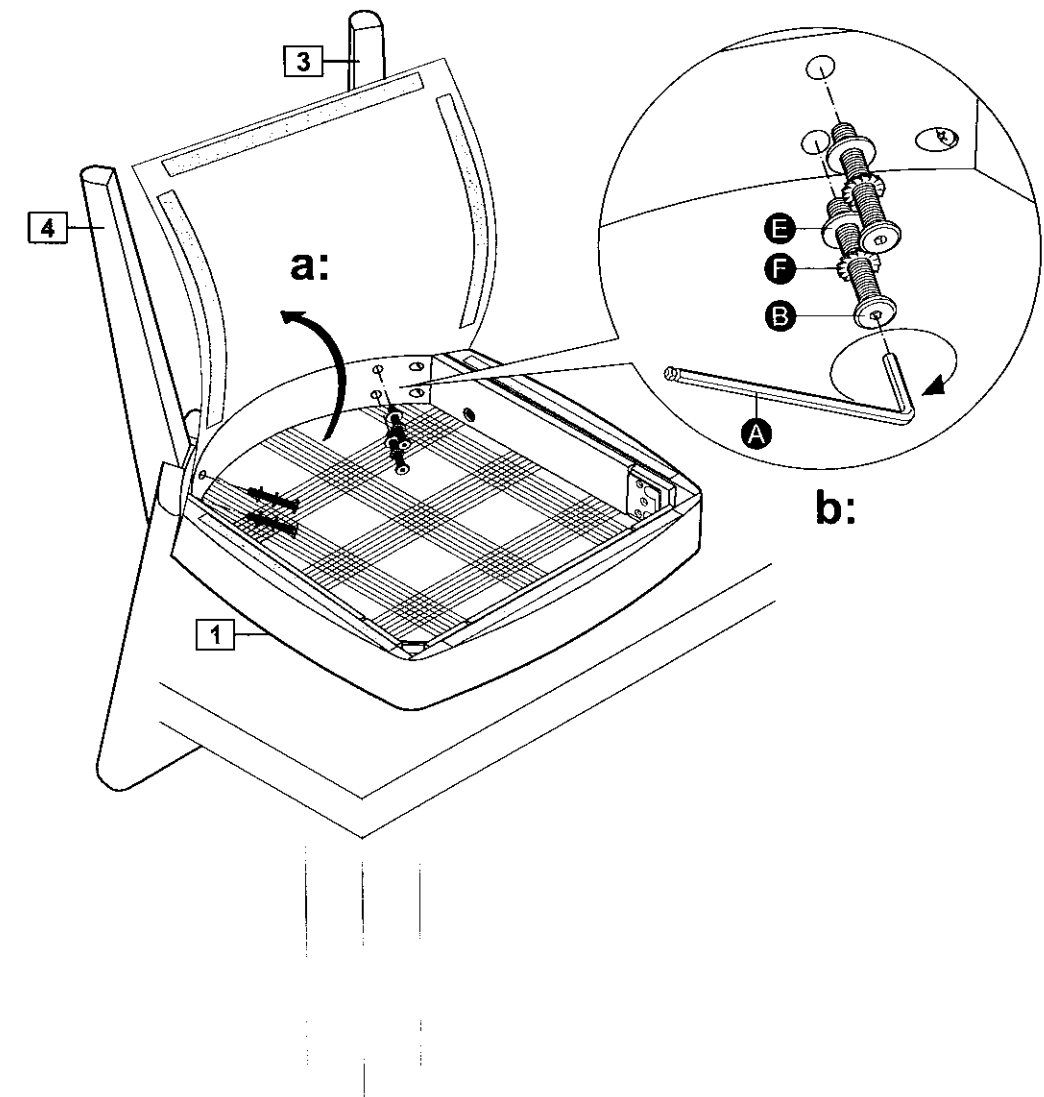
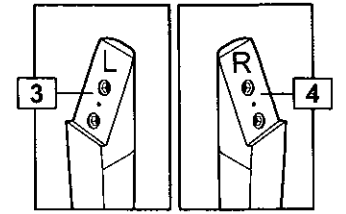

Ruler - Use this ruler to help correctly identify the screws

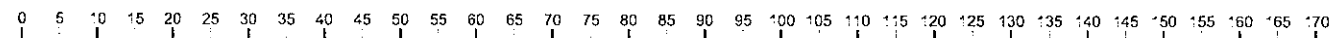

Step 2

Attaching front legs

a: Insert cross dowels **H** into the holes on top of front legs **2** as shown, then attach trim caps **J** onto the holes on top of front legs **2** as shown.

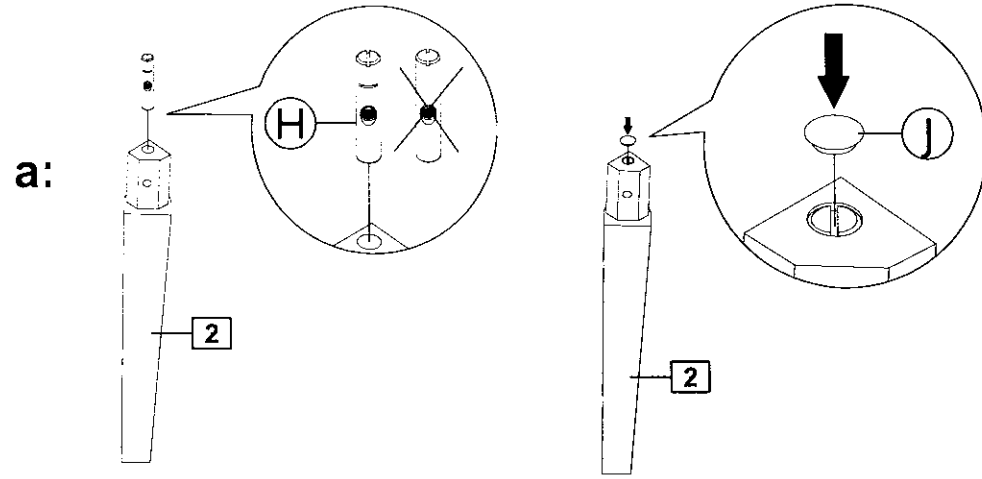

b: Position front legs **2** onto the seat frame **1** as shown.

Note: Ensure the front legs **2** are aligned correctly with seat frame **1** to avoid damage.

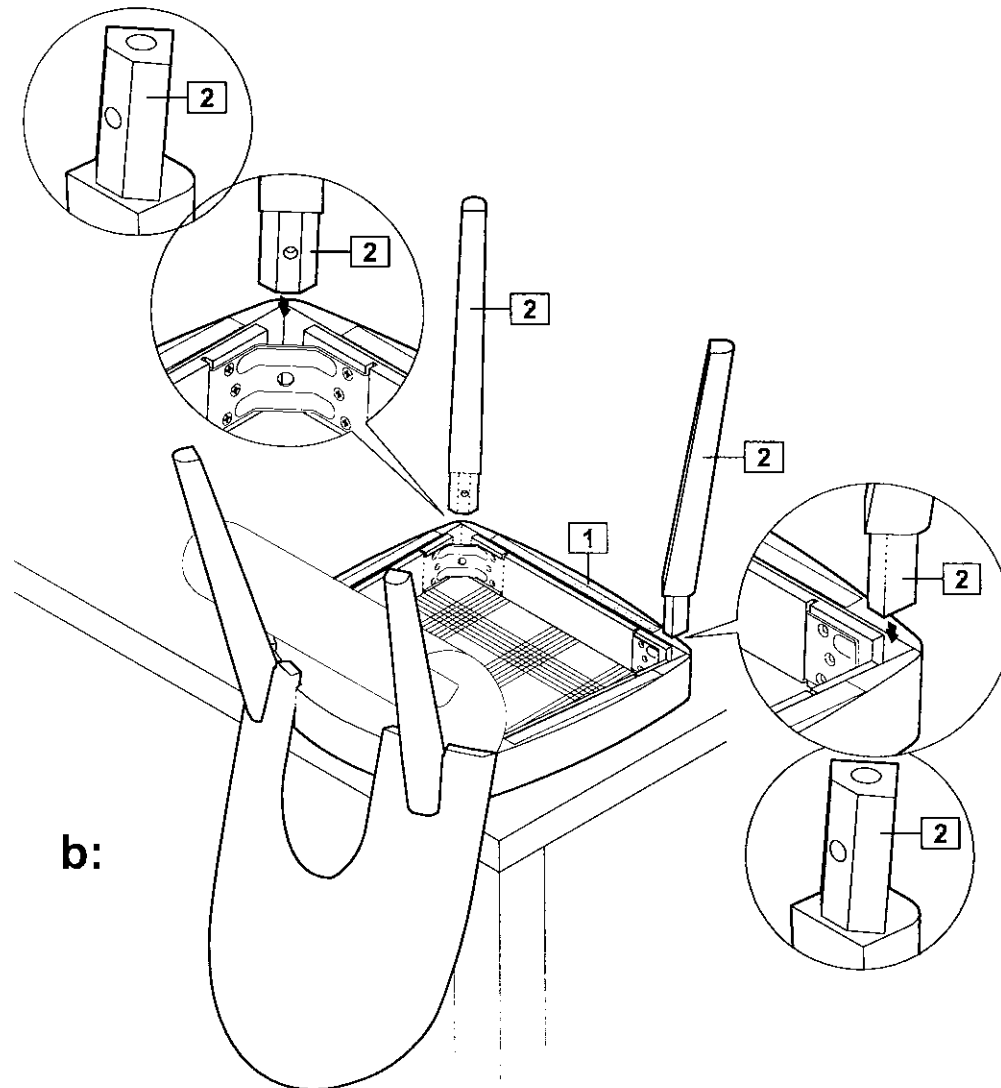

Components - Panels

If you have damaged or missing components, call the Customer Helpline: 08456 400800

Please check you have all the panels listed below

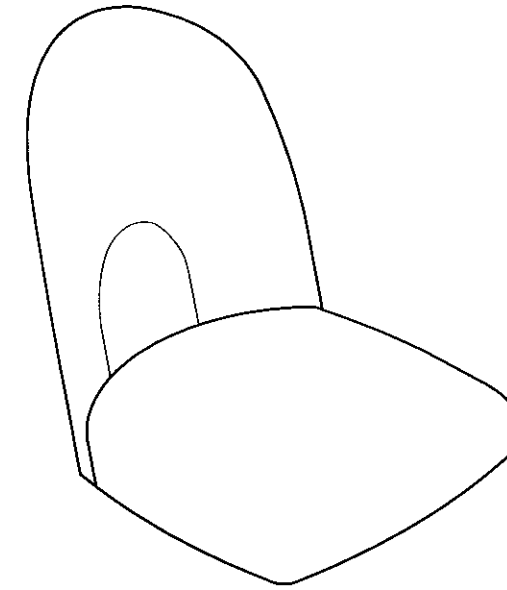

1 Seat frame x 2
(46.0 x 55.0cm)



2 Front legs x 4
(4.1 x 44.4cm)



3 Left back legs x 2
(5.1 x 44.4cm)



4 Right back legs x 2
(5.1 x 44.4cm)



Continued on next page.

Assembly Instructions

Step 4

Attaching under cloth

Place under cloth back onto seat frame **1** by lining up velcro strips and pushing firmly to fix back in place.

Stand the chair upright.

Repeat the complete process for second chair.

Assembly is complete.

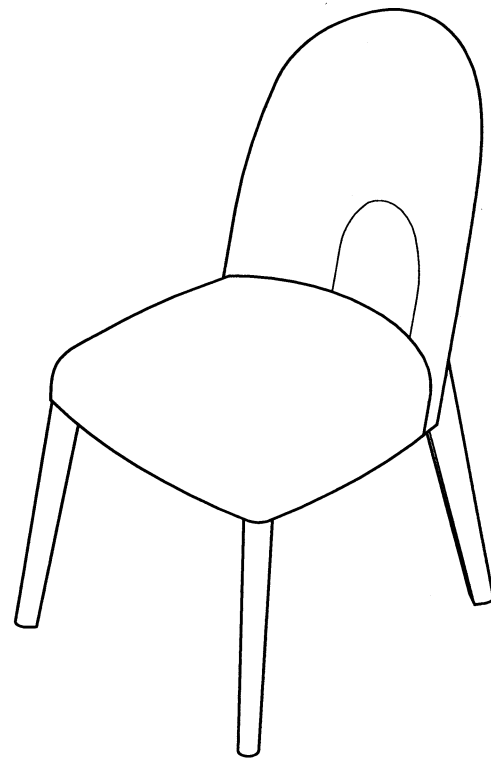
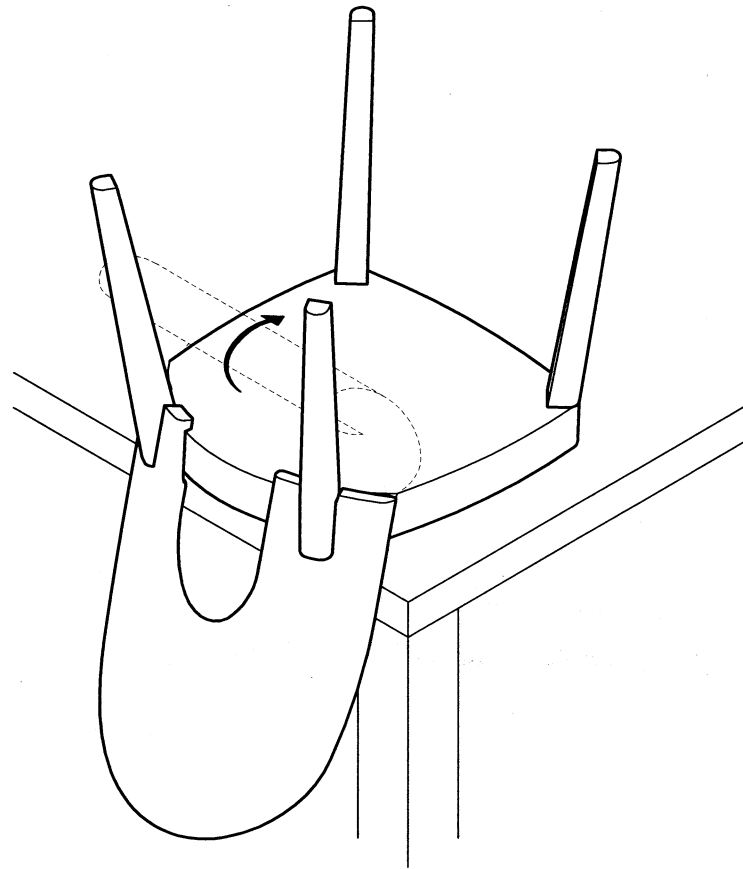

ECR # IW 5909

[Signature]
16/9/13

[Signature]
10/9/13

Emmett - Pair of Upholstered Chairs

Assembly Instructions - Please keep for future reference

149/2772

149/2789

133/0456

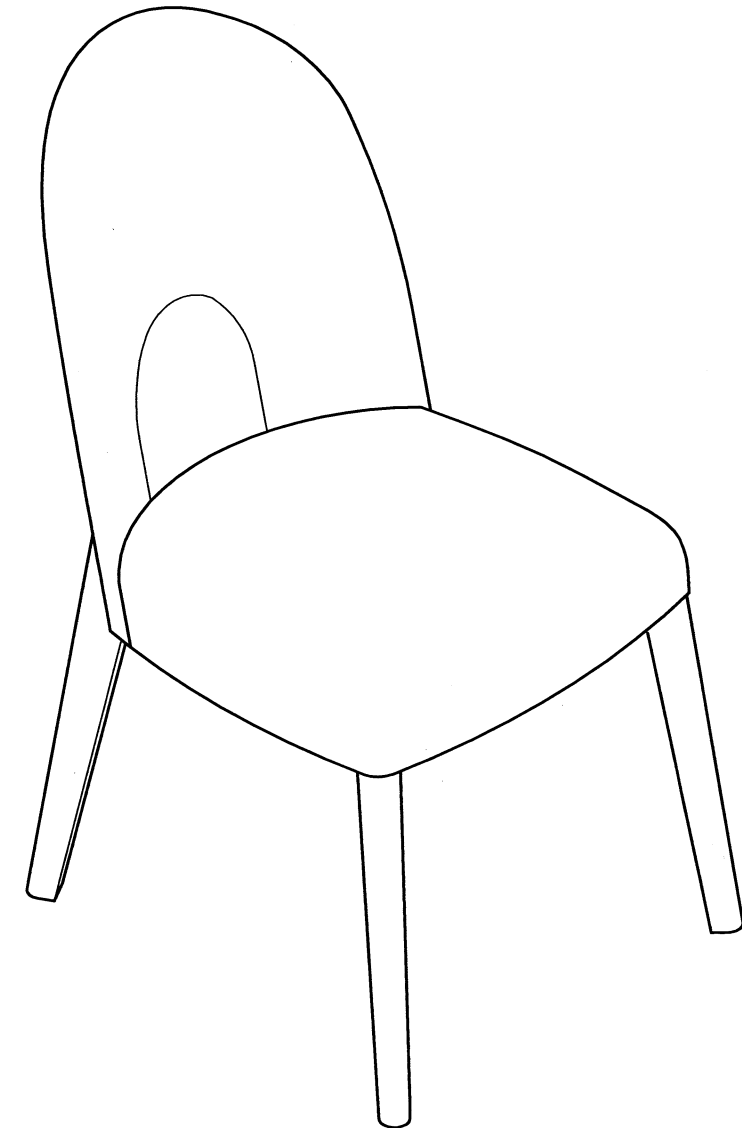

Dimensions

Width - 48cm

Depth - 62cm

Height - 86.5cm

Important - Please read these instructions fully before starting assembly.

If you need help or have damaged or missing parts, call the **Customer Helpline: 08456 400800**



Safety and Care Advice

Important - Please read these instructions fully before starting assembly.

• Check you have all the components and tools listed on page 2 and 3.

• Remove all fittings from the plastic bags and separate them into their groups.

• Keep children and animals away from the work area, small parts could choke if swallowed.

• Make sure you have enough space to layout the parts before starting.

• Do not stand or put weight on the product, this could cause damage.

• Assemble the item as close to its final position (in the same room) as possible.

• Assemble on a soft flat / firm surface to avoid damaging the unit or your floor.

• Parts of the assembly will be easier with 2 people.

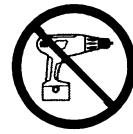

• We do not recommend the use of power drill/ drivers **for inserting screws**,

as this could damage the unit. Only use hand screwdrivers.

• Dispose of all packaging carefully and responsibly .

Care and maintenance

• Only clean using a damp cloth and mild detergent, do no use bleach or abrasive cleaners.

• From time to time check that there are no loose screws on this unit.

• This product should not be discarded with household waste. Take to your local authority waste disposal centre.

Note: if required the next page can be cut out and used as reference throughout the assembly. Keep this page with these instructions for future reference.

Assembly Instructions

Step 3 - continued

C: Insert threaded bolts **D** through the pre-drilled hole of metal corner brackets into front legs **2** as shown.

Note: Ensure bolts **D** are aligned correctly with the fittings inside front legs **2** to avoid damage.

Screw threaded bolts **D** into the fittings **H** that are already concealed in front legs **2** as shown.

d: Insert flat washers **E**, lock washers **F** and hex nut **G** onto threaded bolts **D** on front legs and in order as shown. **E** followed by **F**, **F** followed by **G**.

Tighten hex nut **G** using spanner **C** as shown.

Do not over tighten.

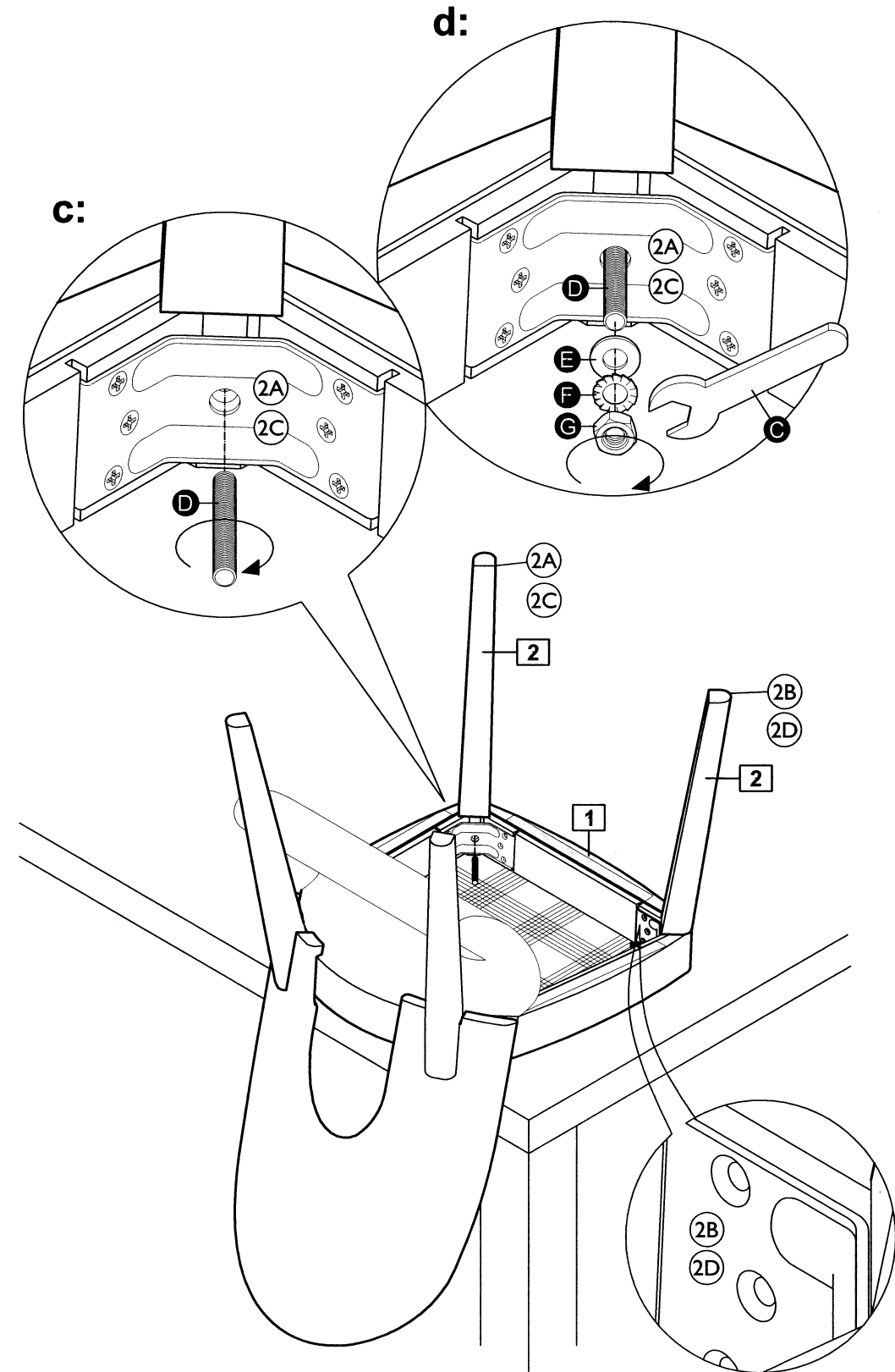

Assembly Instructions

Step 3

Attaching front legs

a: Insert cross dowels **H** into the holes on top of front legs **2** as shown, then attach trim caps **B** onto the holes on top of front legs **2** as shown.

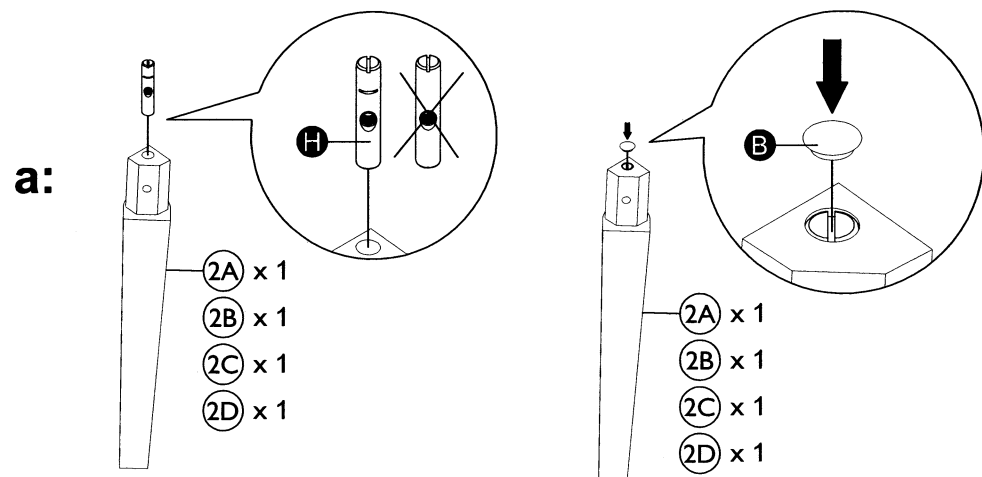

b: Position front legs **2** onto the seat frame **1** as shown.

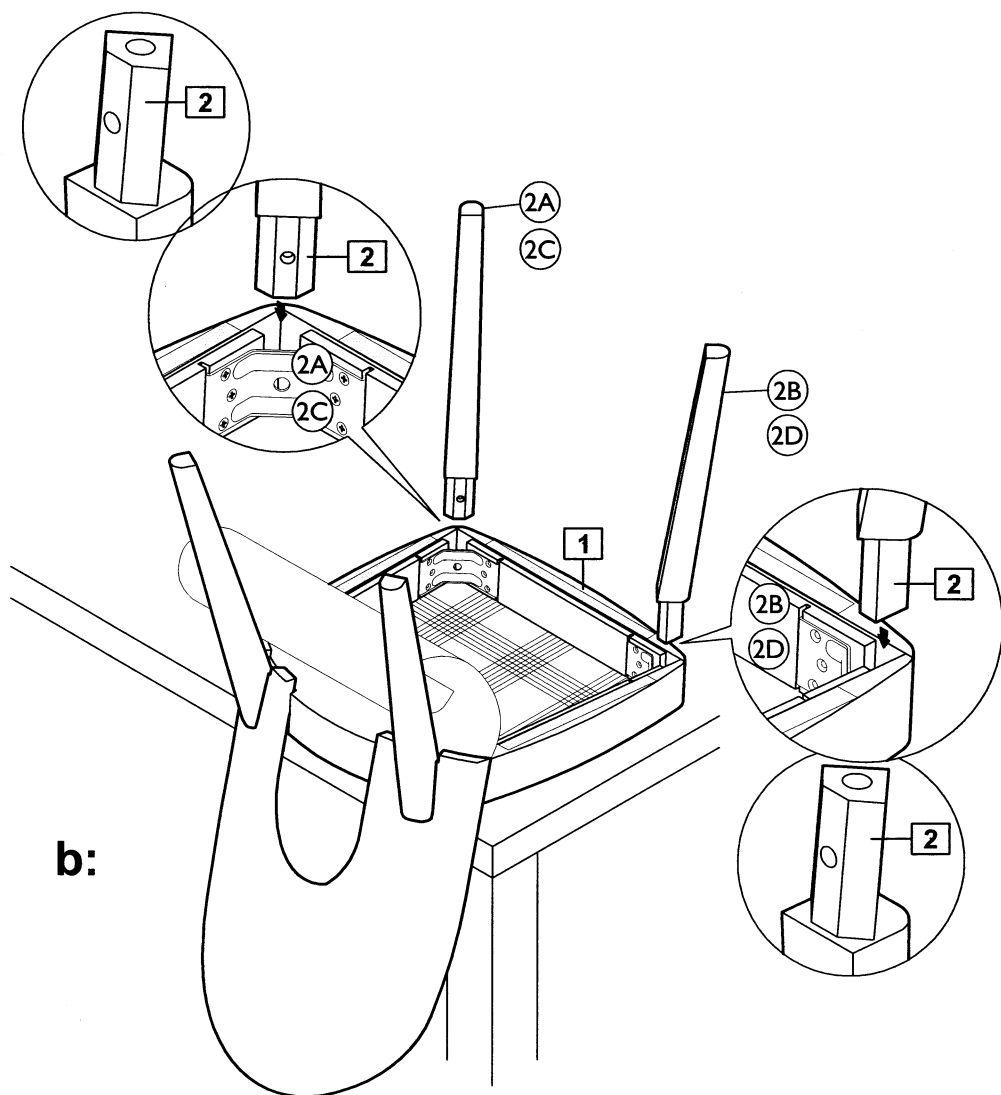

Note: Ensure the front legs **2** are aligned correctly with seat frame **1** to avoid damage.

Continued on next page.

Components - Panels

If you have damaged or missing components, call the Customer Helpline: 08456 400800

Please check you have all the panels listed below

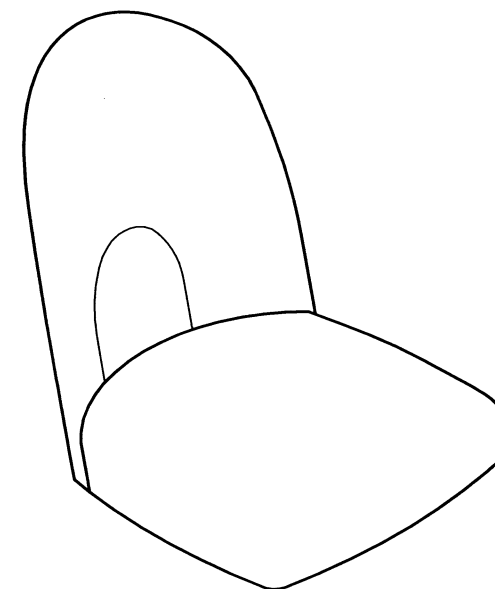

1 Seat frame x 2
(46.0 x 55.0cm)

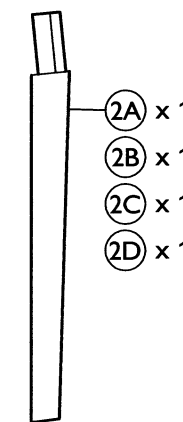

2 Front leg x 4
(4.1 x 44.4cm)

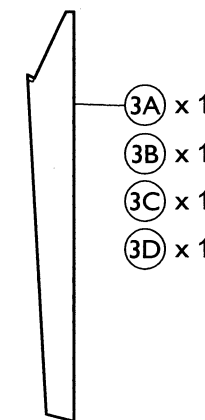







3 Back leg x 4
(5.1 x 44.4cm)

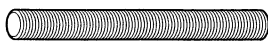

Components - Fittings

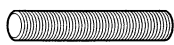
Please check you have all the fittings listed below

Note: The quantities below are the correct amount to complete the assembly. In some cases more fittings may be supplied than are required.

A  90mm Threaded bolt x 8	B  Trim cap plastic x 4	C  Spanner x 1
D  50mm Threaded bolt x 4	E  Flat washer x 12	F  Lock washer x 12
G  Hex nut x 12	H  Cross dowel x 4	

Assembly Instructions

Step 1

Fitting dowels

Insert threaded bolts **A** into the hole on back legs **3**.

Tighten threaded bolts **A** into the holes of back legs **3** as shown.

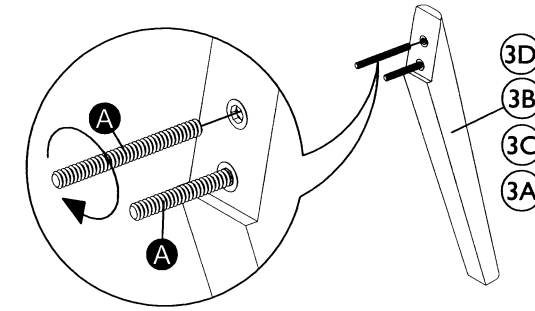

Step 2

Attaching back legs

a: Attach back leg **3** onto seat frame **1** by inserting bolt **A** into the pre-drilled holes of seat frame **1** as shown.

b: Insert flat washer **E**, lock washer **F** and hex nut **G** onto threaded bolts **A** on back leg **3** and in order as shown.

E followed by **F**.
F followed by **G**.

Tighten hex nut **G** using spanner **C** as shown.

Note: Do not over tighten.

Repeat Step 2 with the remaining back leg.

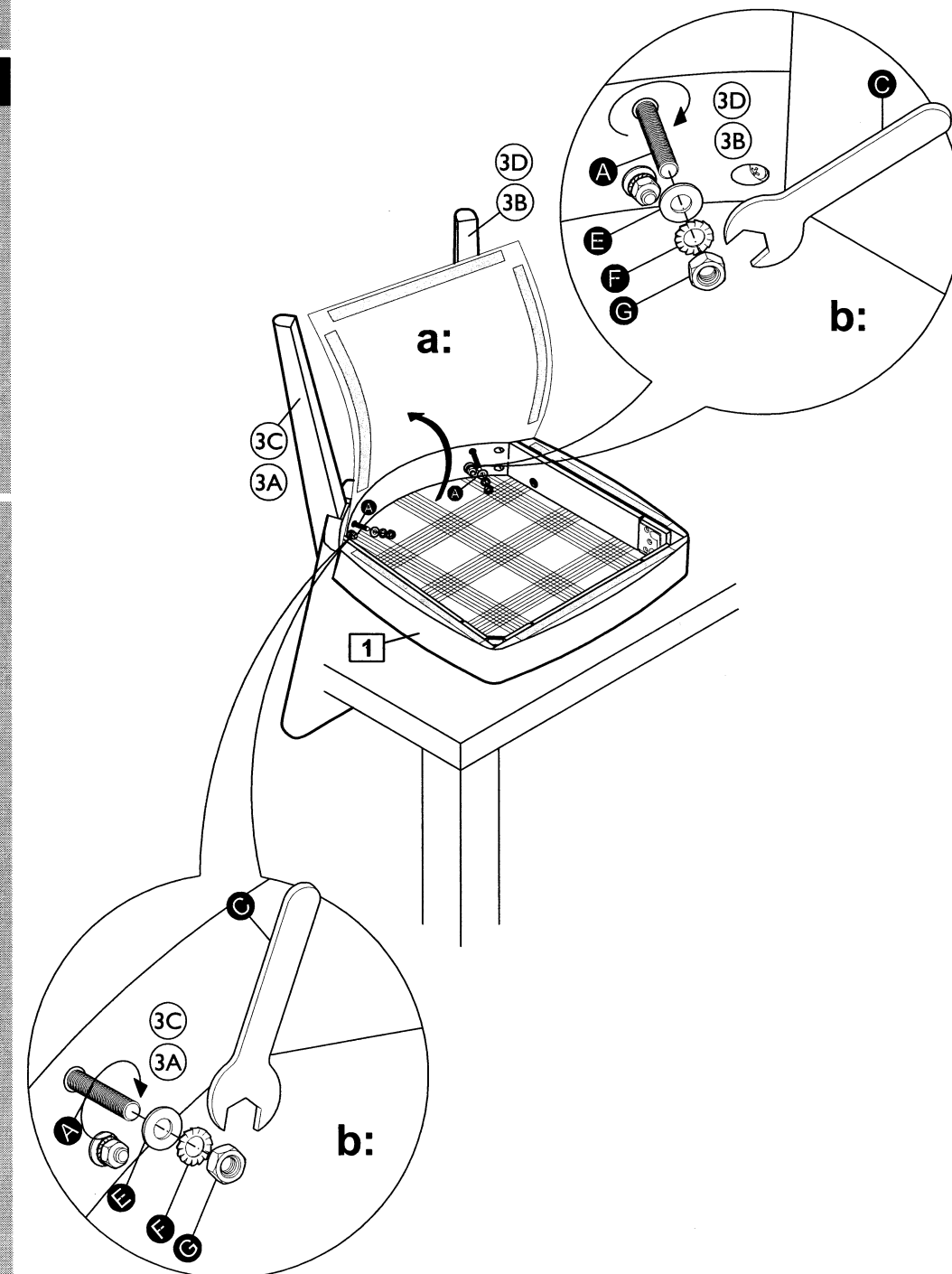

Ruler - Use this ruler to help correctly identify the screws

