

Cucina Walnut Dining Table

ECR # IW 4750

Assembly Instructions - Please keep for future reference

603/0713

AR
8/1/13

AR
8/1/13

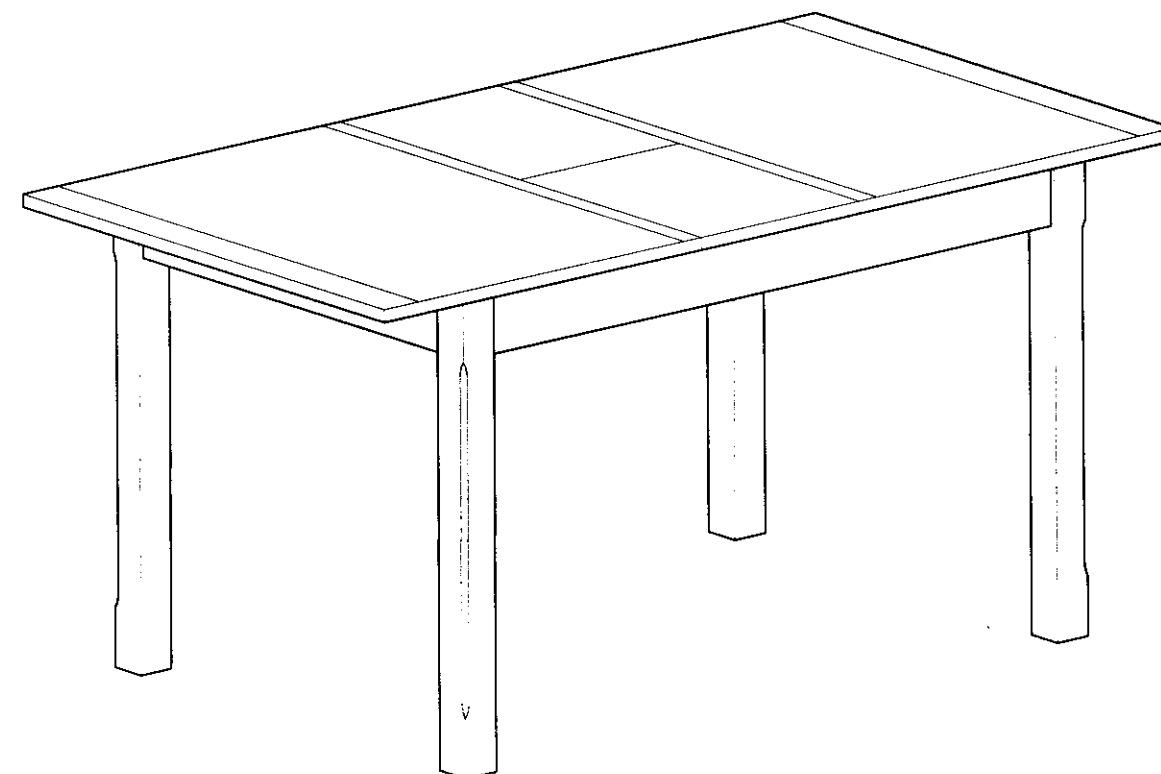

Dimensions

Width - 120/ 150cm
Depth - 80cm
Height - 73.5cm

Important - Please read these instructions fully before starting assembly.

If you need help or have damaged or missing parts, call the **Customer Helpline: 08456 400800**

Assembly Instructions

Step 1

Fitting dowels

a: Insert cross dowels **A** into the holes on top of legs **1**.

Note: Ensure the horizontal marking on each cross dowel is facing out as shown.

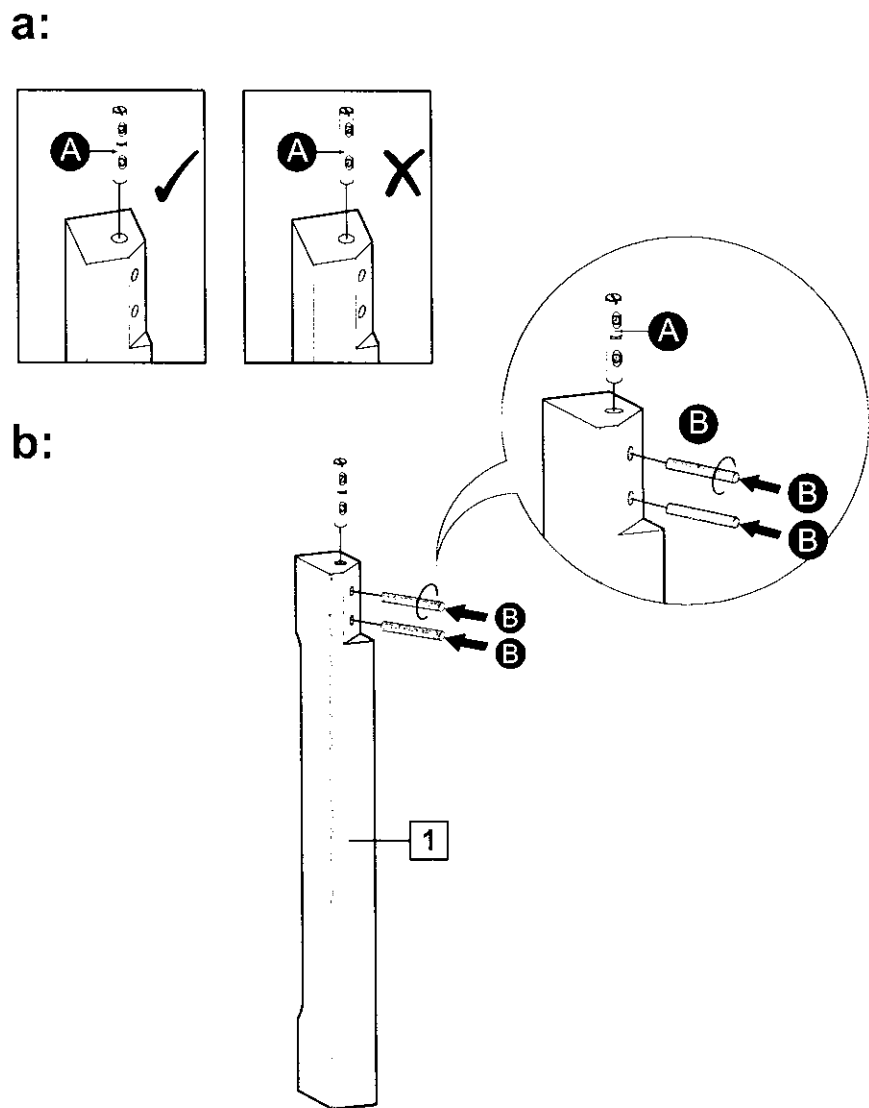

b: Insert 2 threaded bolts **B** into the two holes on all legs **1**.

Screw threaded bolts **B** into the holes of cross dowels **A** that are already concealed in all legs **1** as shown.

Step 2

Attaching legs

a: Lay table top **2** on a flat, stable, clean and soft surface.

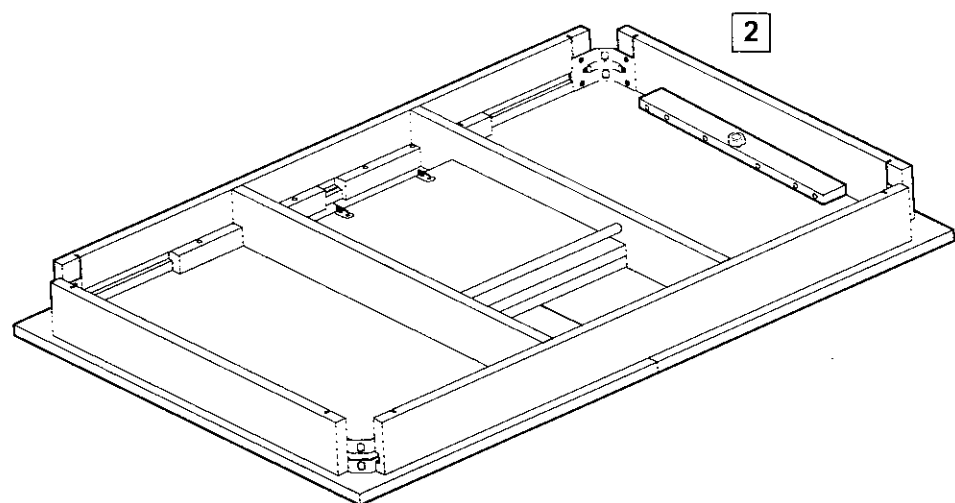

Step 2 - continued

Attaching legs

b: Attach leg **1** onto table top **2** by inserting bolts **B** into the pre-drilled holes of metal corner bracket as shown.

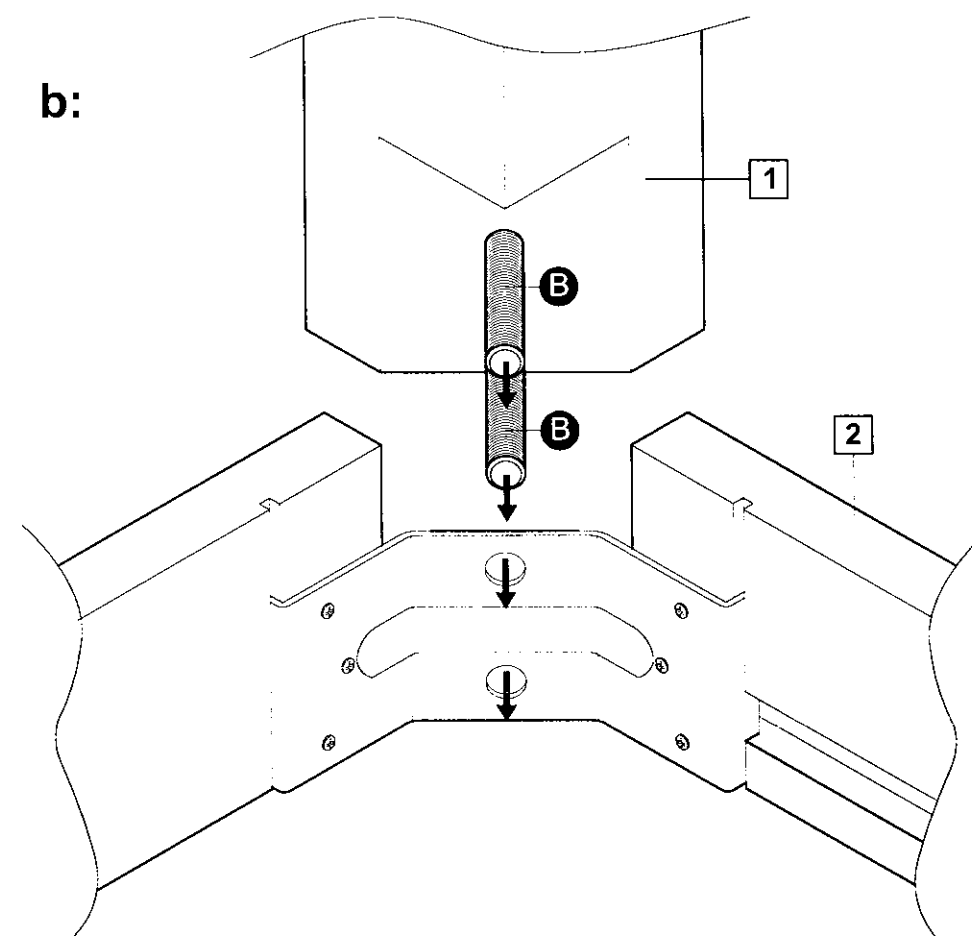

c: Insert flat washer **C**, lock washer **D** and hex nut **E** onto the two threaded bolts **B** on leg **1** and in order as shown.

C followed by **D**
D followed by **E**.

Tighten hex nut **E** using spanner **F** as shown.

Note:
Do not over tighten.

c: Repeat steps **b:** and **c:** with the remaining 3 legs.

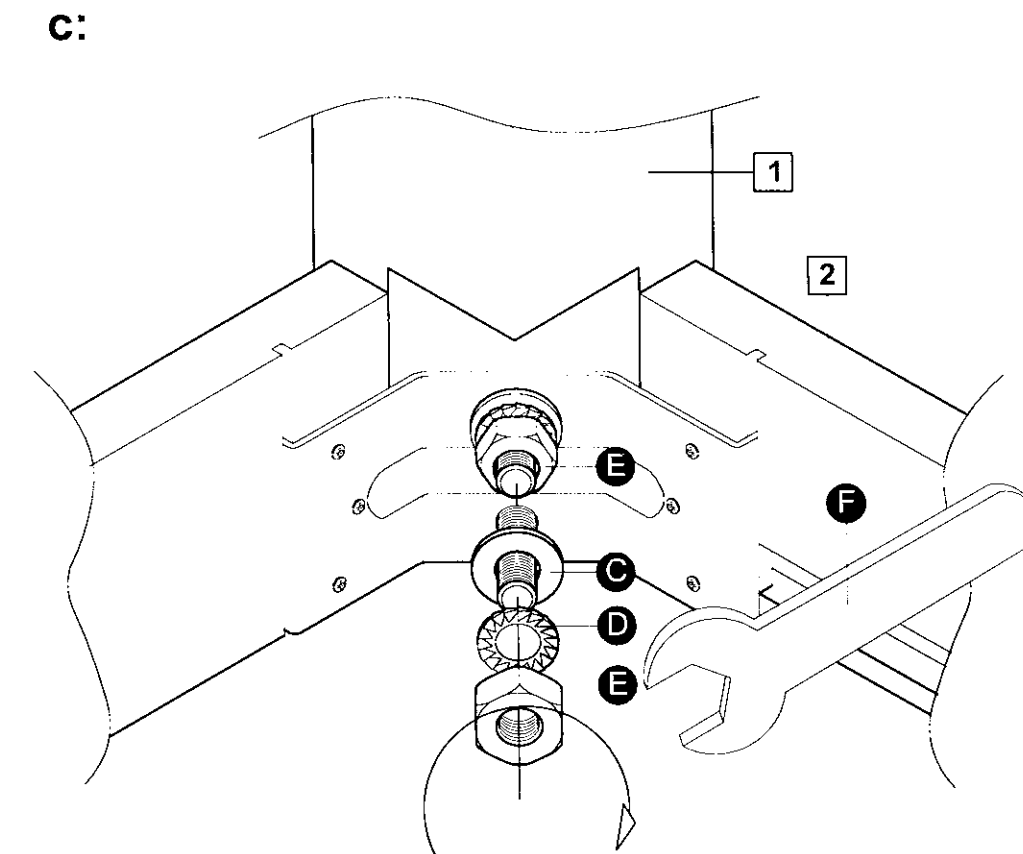

Continued on next page.

Safety and Care Advice

Important - Please read these instructions fully before starting assembly.

- Check you have all the components and tools listed on page 2.
- Remove all fittings from the plastic bags and separate them into their groups.
- Keep children and animals away from the work area, small parts could choke if swallowed.
- Make sure you have enough space to layout the parts before starting.
- Do not stand or put weight on the product, this could cause damage.
- Assemble the item as close to its final position (in the same room) as possible.
- Assemble on a soft flat / firm surface to avoid damaging the unit or your floor.
- Parts of the assembly will be easier with 2 people.



- We do not recommend the use of power drill/ drivers **for inserting screws**, as this could damage the unit. Only use hand screwdrivers.

- Dispose of all packaging carefully and responsibly.

Care and maintenance

- Only clean using a damp cloth and mild detergent, do not use bleach or abrasive cleaners.
- From time to time check that there are no loose screws on this unit.
- This product should not be discarded with household waste. Take to your local authority waste disposal centre.

Step 4 - continued

Extending table continued

- b:** Push ends of table inwards until no gap is visible.

Note: Make sure dowels line up with holes on mating panel to avoid damage.

b:

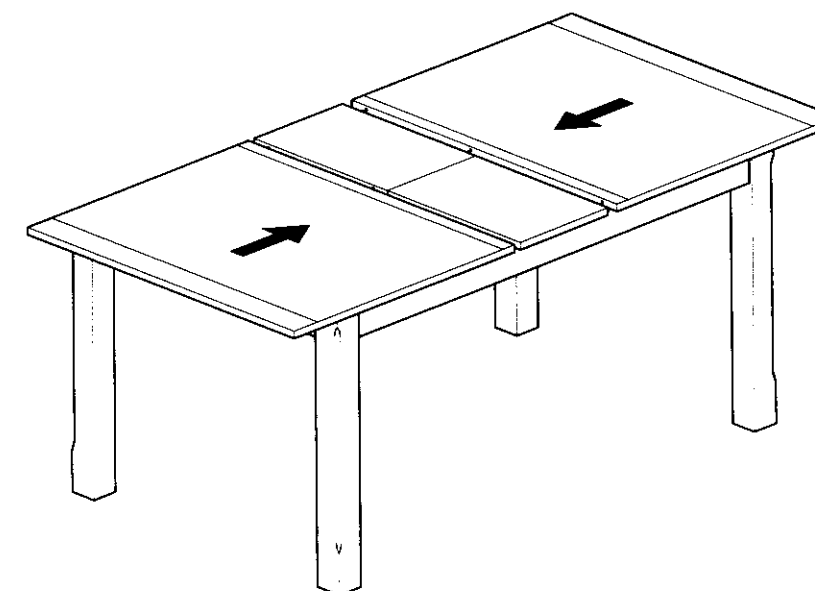

c:

- c:** Turn thumbscrews clockwise to lock table top in place.

Note: To close table, reverse the procedure.

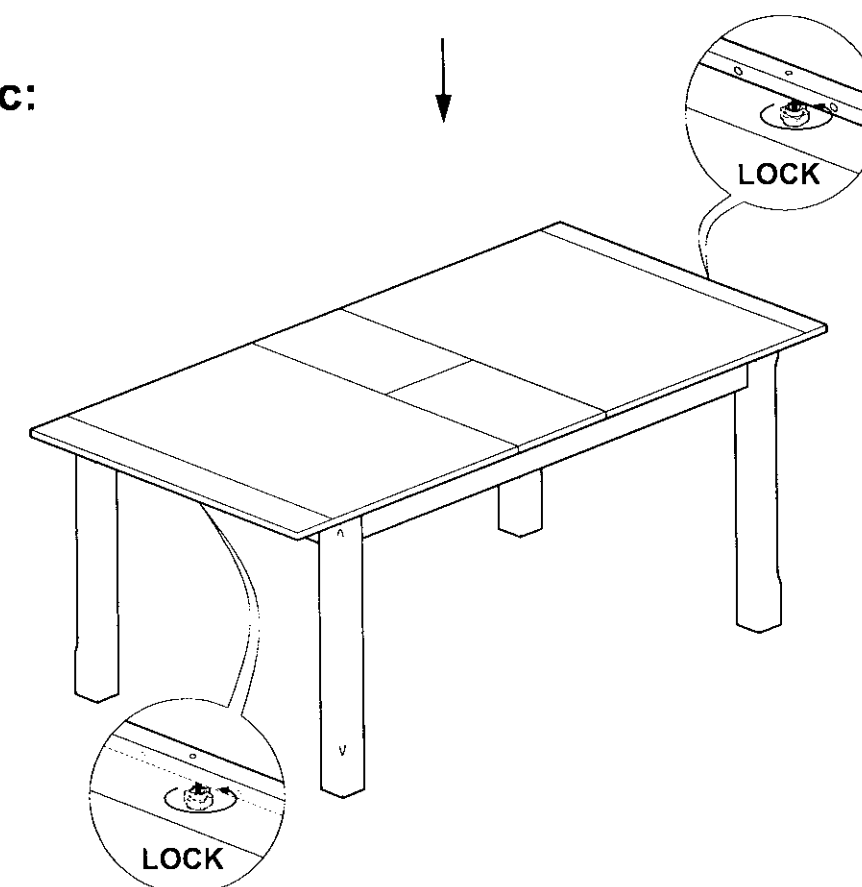

If you need help or have damaged or missing parts, call the **Customer Helpline: 08456 400800**

Step 3

Stand the table upright

Turn thumbscrews clockwise to lock table top in place.

With help, carefully stand dining table upright.

Important: LOCK table top before righting the table.

Warning: The dining table is heavy. Lift with care.

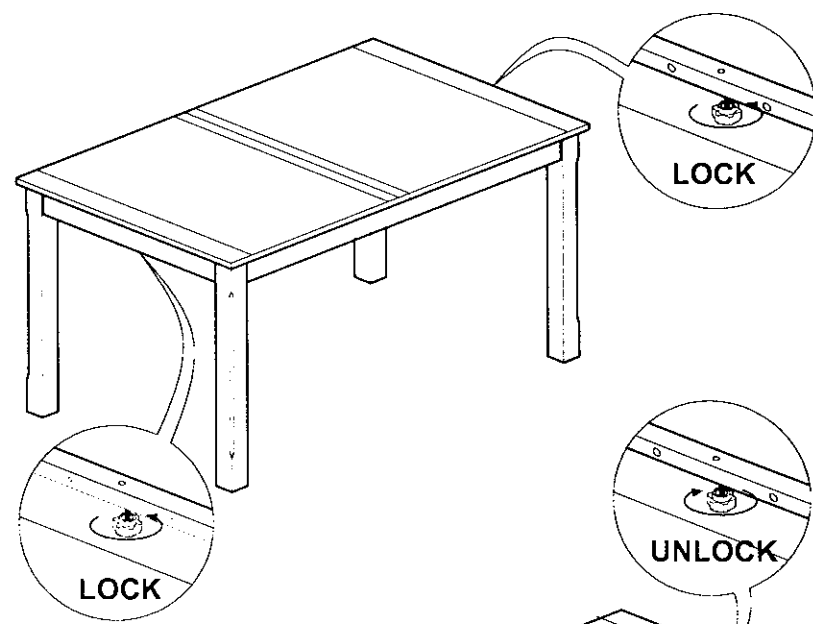

Step 4

Extending table

a: Locate thumbscrews under table ends and turn counterclockwise until clear of locking holes on underside of table top.

Pull table top apart as shown, until butterfly leaf is clearly visible underneath.

Important: UNLOCK table top before extending the table.

Pull top piece of butterfly leaf up and lay flat as shown.

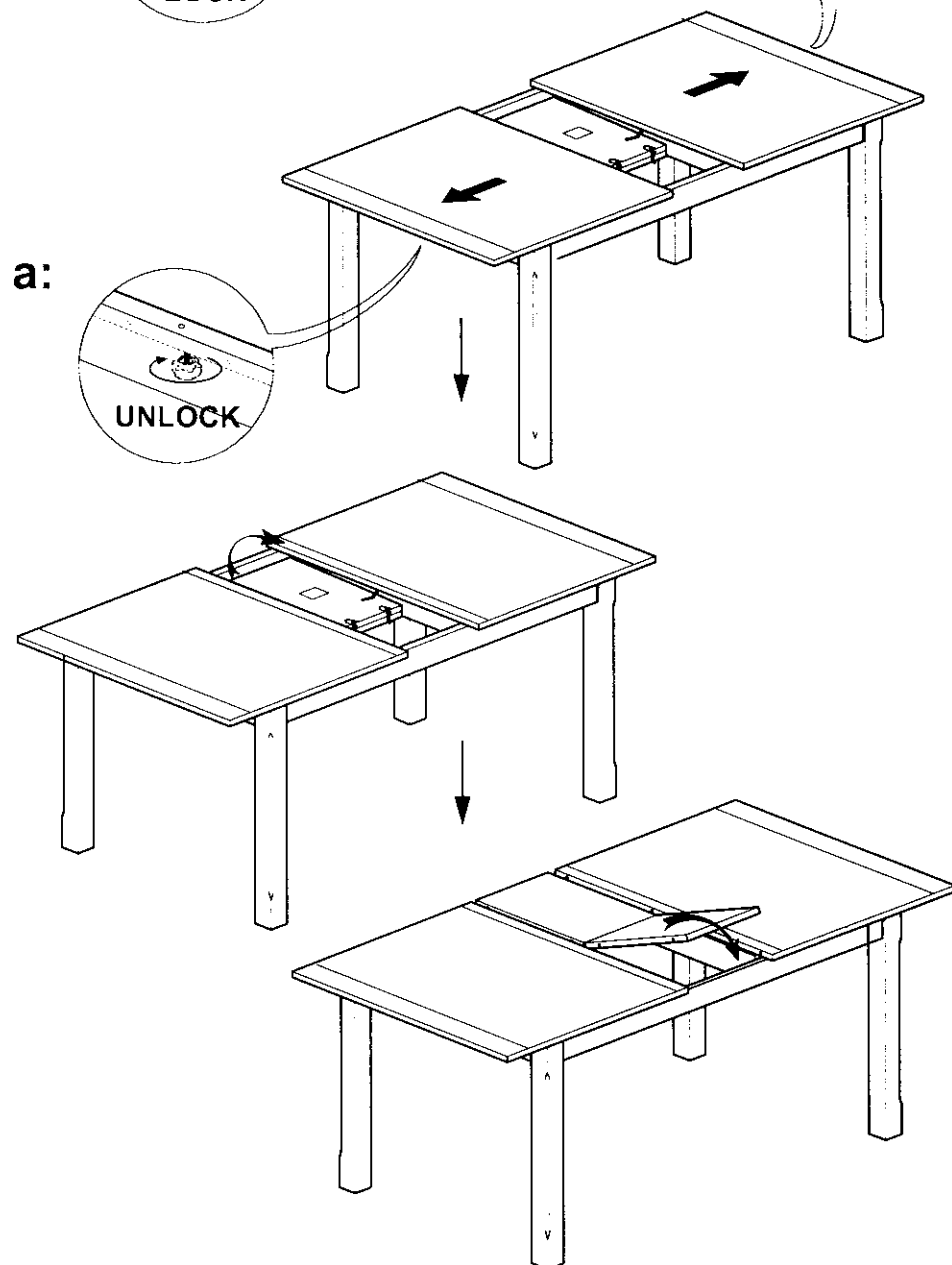

Continued on next page.

Components-Table tops & Legs

If you have damaged or missing components, call the **Customer Helpline: 08456 400800**

Please check you have all the panels listed below.

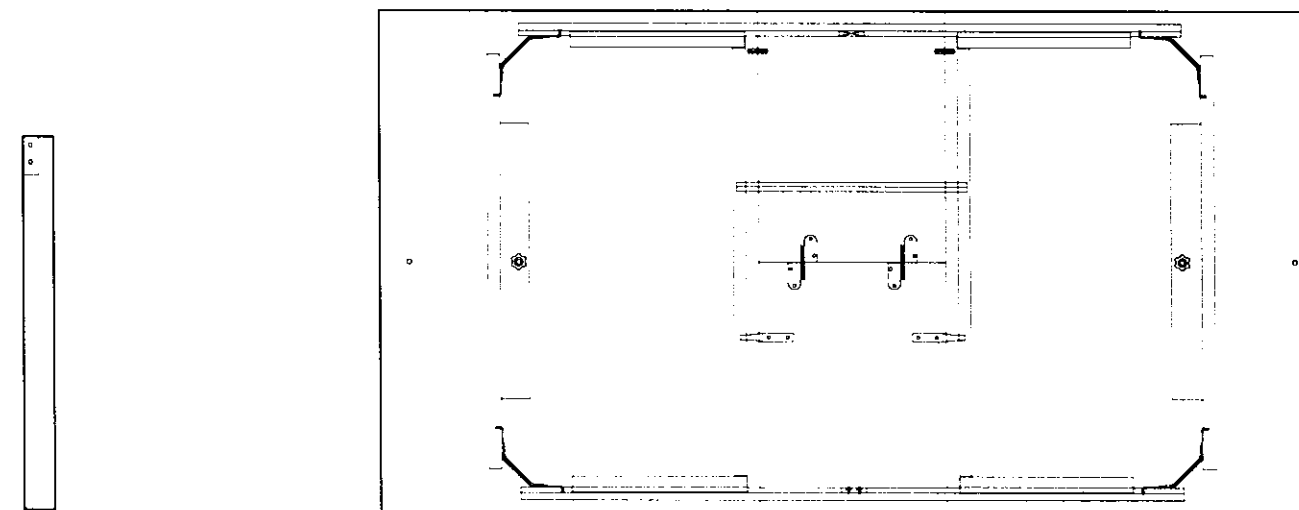







1 Legs x 4
(5.9 x 71.4cm)

2 Table top (120/150 x 80cm)

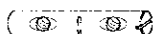
Components - Fittings

Please check you have all the fittings listed below.

Note: The quantities below are the correct amount to complete the assembly. In some cases more fittings may be supplied than are required.

A 	B 	C 
60mm Cross dowel x 4	70mm Threaded bolt x 8	Flat washer x 8
D 	E 	F 
Lock washer x 8	Hex nut x 8	Spanner x 1

Ruler - Use this ruler to help correctly identify the screws

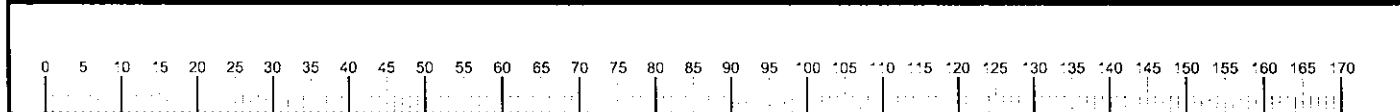

Cucina Walnut - Pair of Chairs

Assembly Instructions - Please keep for future reference

603/0720

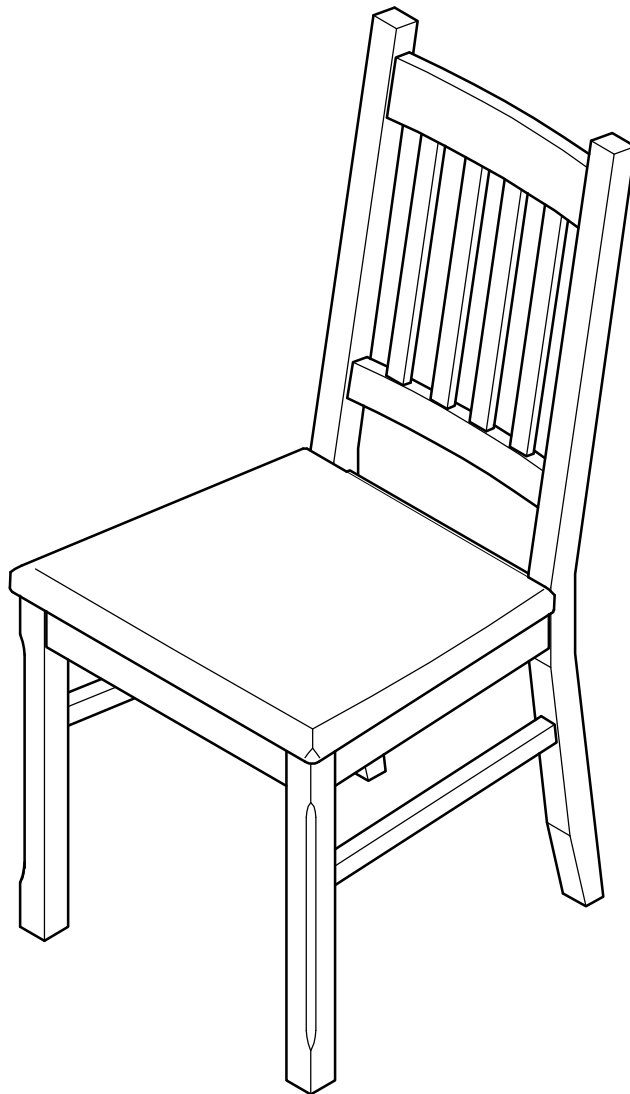

Dimensions

Width - 44cm

Depth - 51.6cm

Height - 92cm

Important - Please read these instructions fully before starting assembly.

If you need help or have damaged or missing parts, call the **Customer Helpline: 08456 400800**



Safety and Care Advice

Important - Please read these instructions fully before starting assembly.

- Check you have all the components and tools listed on page 2.

- Remove all fittings from the plastic bags and separate them into their groups.

- Keep children and animals away from the work area, small parts could choke if swallowed.

- Make sure you have enough space to layout the parts before starting.

- Do not stand or put weight on the product, this could cause damage.

- Assemble the item as close to its final position (in the same room) as possible.

- Assemble on a soft flat / firm surface to avoid damaging the unit or your floor.

- Parts of the assembly will be easier with 2 people.



- We do not recommend the use of power drill/ drivers **for inserting screws**, as this could damage the unit. Only use hand screwdrivers.

- Dispose of all packaging carefully and responsibly.

- The maximum safe weight of user: 110Kg.

Care and maintenance

- Only clean using a damp cloth and mild detergent, do no use bleach or abrasive cleaners.

- From time to time check that there are no loose screws on this unit.

- This product should not be discarded with household waste. Take to your local authority waste disposal centre.

Components - Panels

If you have damaged or missing components, call the **Customer Helpline: 08456 400800**

Please check you have all the panels listed below.

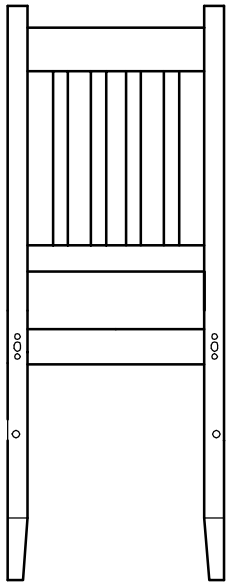

1 Back leg frame
(35 x 92cm)



2 Left apron
(37 x 5.5cm)

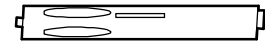

3 Right apron
(37 x 5.5cm)

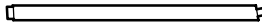

4 Left stretcher
(38.1 x 2.4cm)

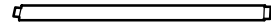

5 Right stretcher
(38.1 x 2.4cm)

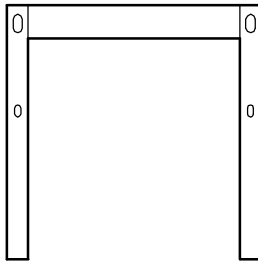

6 Front leg frame
(42 x 42cm)

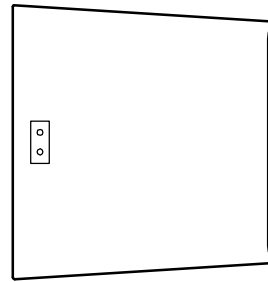





7 Seat pad
(41.5 x 44.2cm)

Components - Fittings

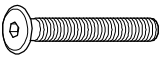
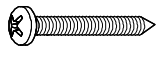
Please check you have all the fittings listed below.

Note: The quantities below are the correct amount to complete the assembly. In some cases more fittings may be supplied than are required.

<p>A </p> <p>60mm Hex head bolt x 6</p>	<p>B </p> <p>50mm Round head screw x 4</p>	<p>C </p> <p>15mm Hex head bolt x 2</p>
<p>D </p> <p>Seat bracket x 2</p>	<p>E </p> <p>Allen key</p>	

Tools required

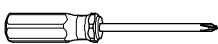

Phillips screwdriver
(medium & large)

Ruler - Use this ruler to help correctly identify the screws

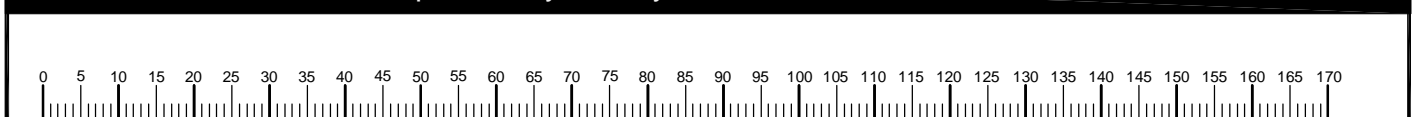

Assembly Instructions

Step 1

Attaching aprons and stretchers.

a: Position left apron **2**, and right apron **3** onto back leg frame **1**

Insert 4 hex head bolts **A** into left apron **2** and right apron **3**.

Use allen key **E** to turn hex head bolts **A** clockwise to fix.

Note: Please ensure slot on left apron **2** is in the position indicated.

b: Position left stretcher **4** and right stretcher **5** onto back leg frame **1**

Insert 2 round head screw **B** into left stretcher **4** and right stretcher **5**.

Use screwdriver to turn round head screws **B** clockwise to fix.

Note: Back leg frame **1** has different sized holes for left and right stretchers **4** & **5**.

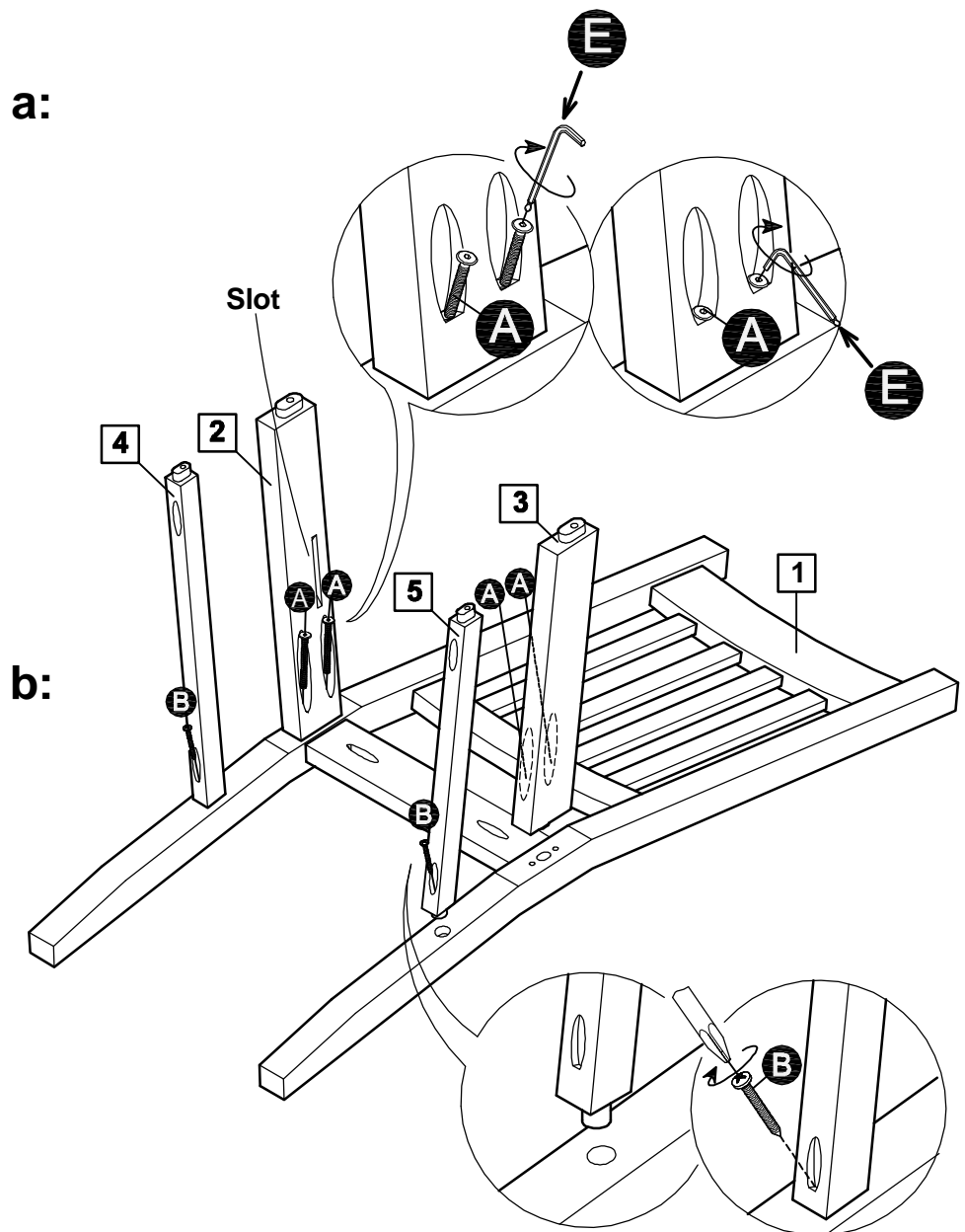

Assembly Instructions

Step 2

Attaching front leg frame.

Position front leg frame **6** onto left apron **2**, right apron **3** and both left & right stretchers **4** & **5**.

Note: Ensure the dowels are aligned correctly with mating front leg frame to avoid damage.

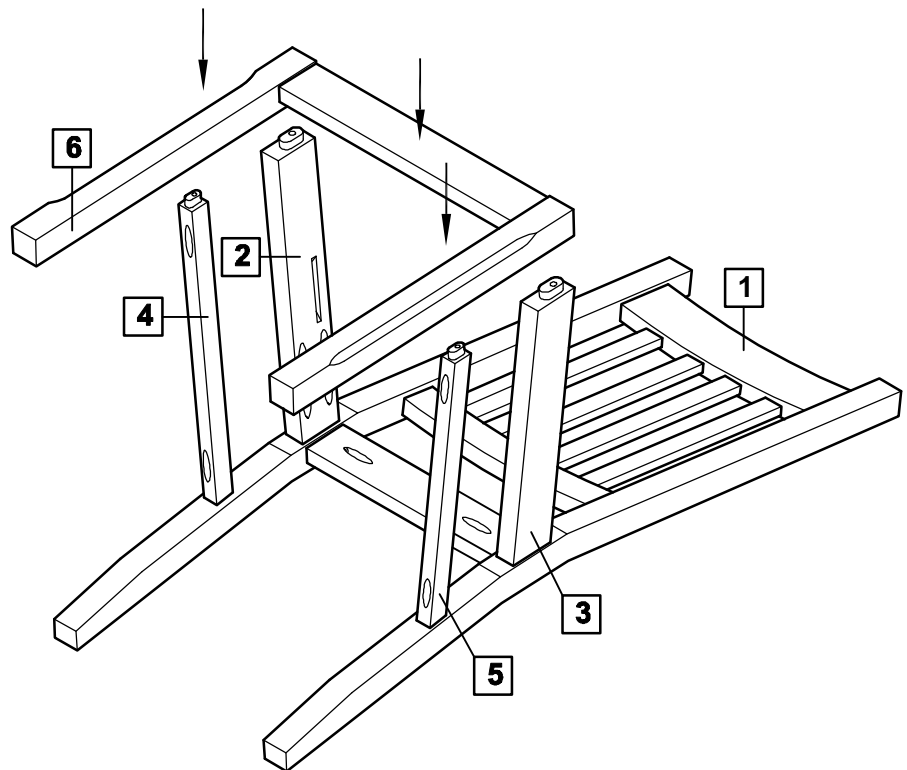

Assembly Instructions

Step 3

Fixing front leg frame.

Carefully stand chair upright.

Insert 2 hex head bolt **A** into the predrilled holes on left apron **2** and right apron **3**.

Use allen key **E** to turn hex head bolts **A** clockwise to fix.

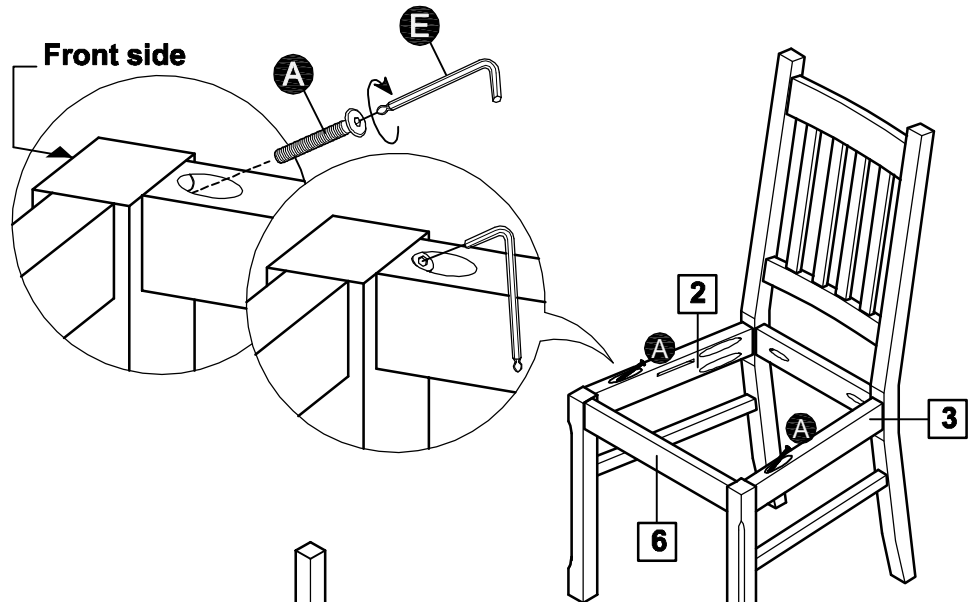

Step 4

Fixing stretchers.

Place chair frame upside down onto a flat, stable, clean and soft surface as shown.

Insert 2 round head screws **B** into the predrilled holes on left stretcher **4** and right stretcher **5**.

Use screw driver to turn round head screws **B** clockwise to fix.

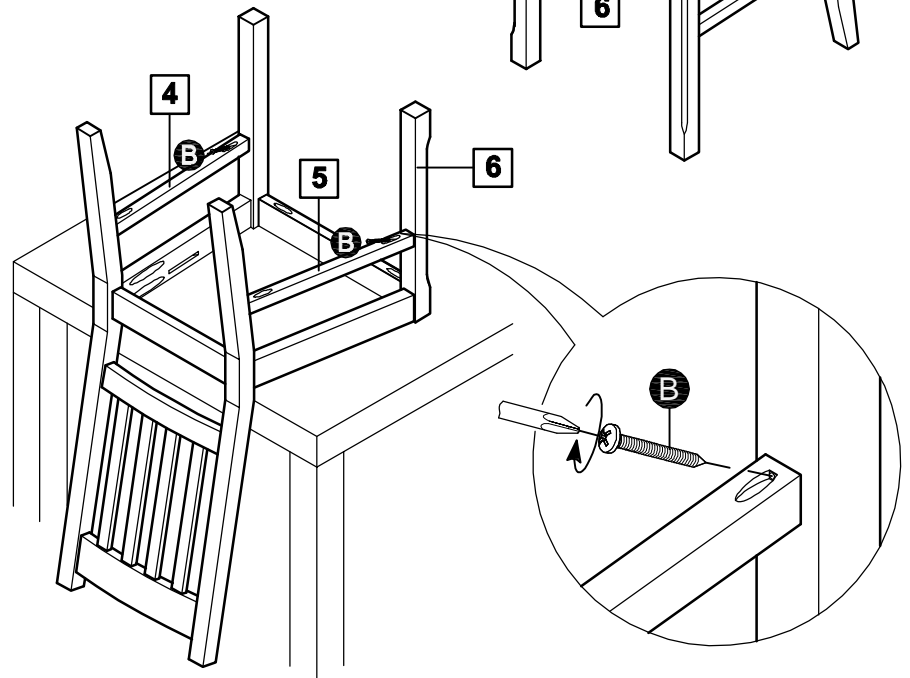

Step 5

Placing seat pad.

a: Lift chair frame up and place seat pad **7** below the chair with wooden locator block positioned as shown.

b: Lower chair frame onto seat pad **7**,
Ensure wooden locator block is inside front leg frame **6** as shown.

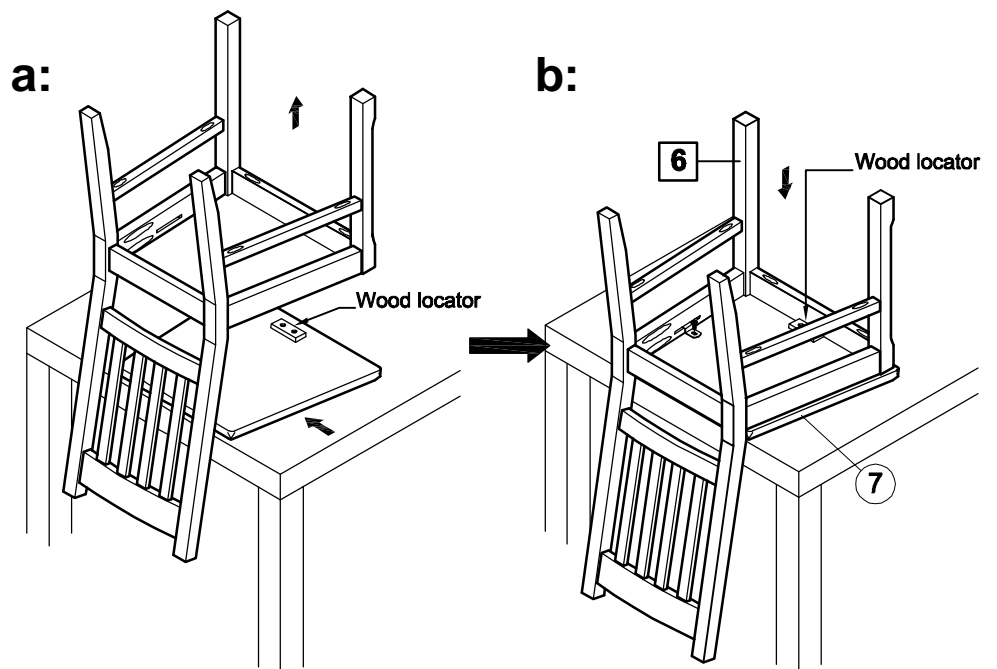

Assembly Instructions

Step 6

Fixing seat pad.

a: Insert 2 seat brackets **D** into the slots on left apron **2** and right apron **3**.

Note: Align holes on seat brackets **D** with holes on seat pad **7**.

b: Insert 2 hex head bolts **G** into the holes of seat brackets **D** and the holes of mating seat pad **7**.

Use allen key **E** to turn hex head bolts **G** clockwise to lock.

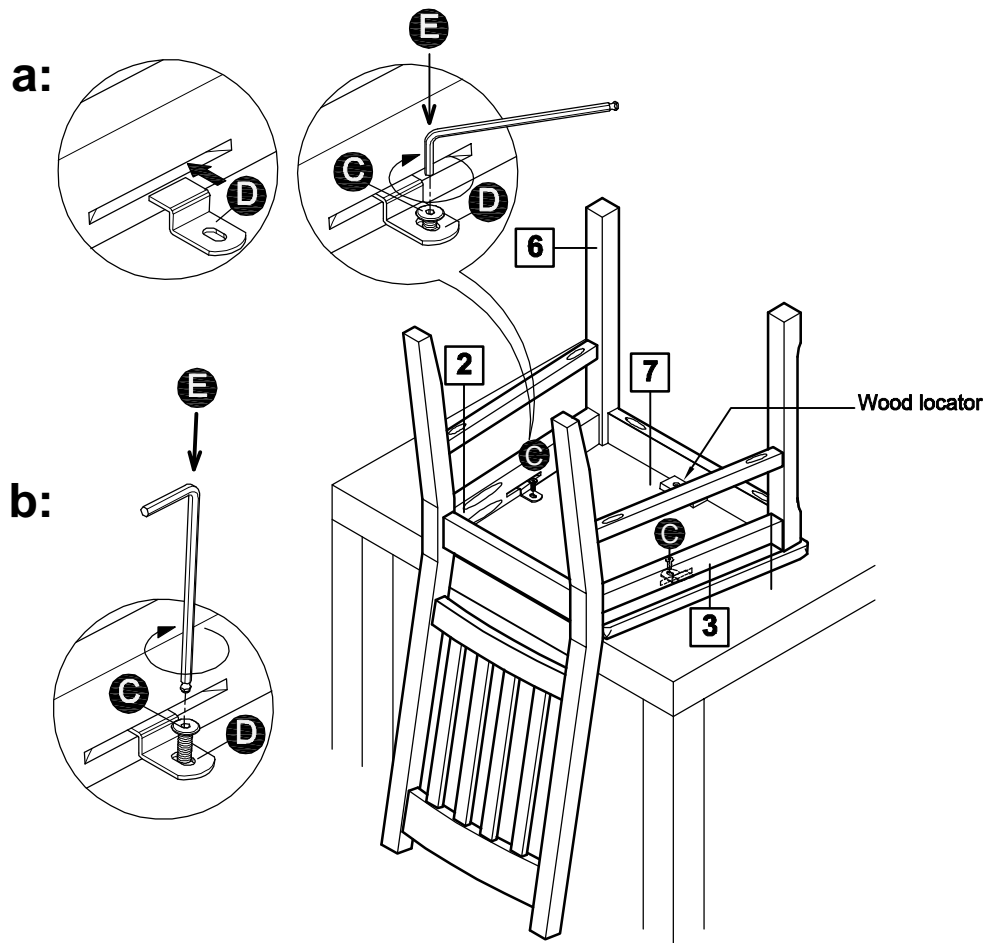

Repeat complete process for second chair.

Assembly is complete.

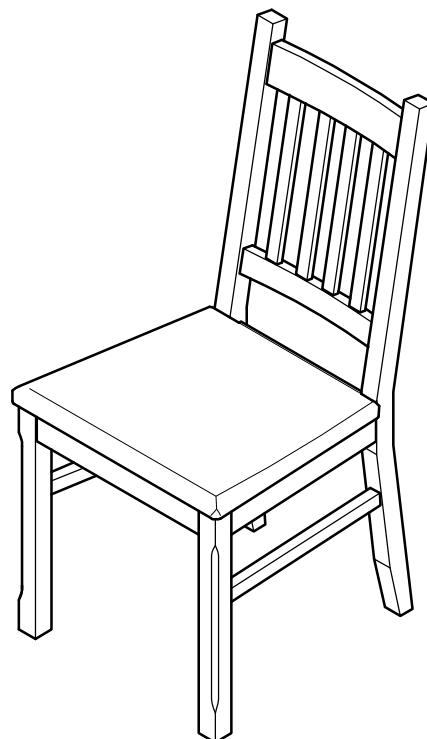

If you need help or have damaged or missing parts, call the **Customer Helpline: 08456 400800**

Assembly Instructions

Step 6

Fixing seat pad.

a: Insert 2 seat brackets **D** into the slots on aprons **2**, **3** as shown.

Note: Align holes on seat brackets **D** with holes on seat pad **7**.

b: Insert 2 hex head bolts **C** into the holes of seat brackets **D** and the holes of mating seat pad **7** as shown.

Use allen key **E** to turn hex head bolts **C** clockwise to fix.

Repeat complete process for second chair.

Assembly is complete.

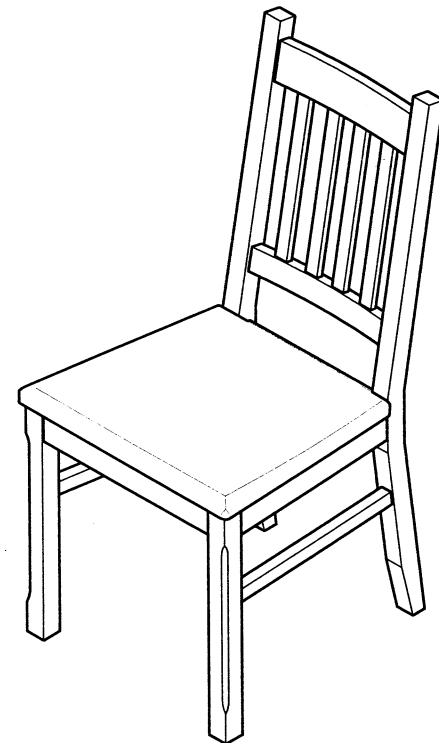
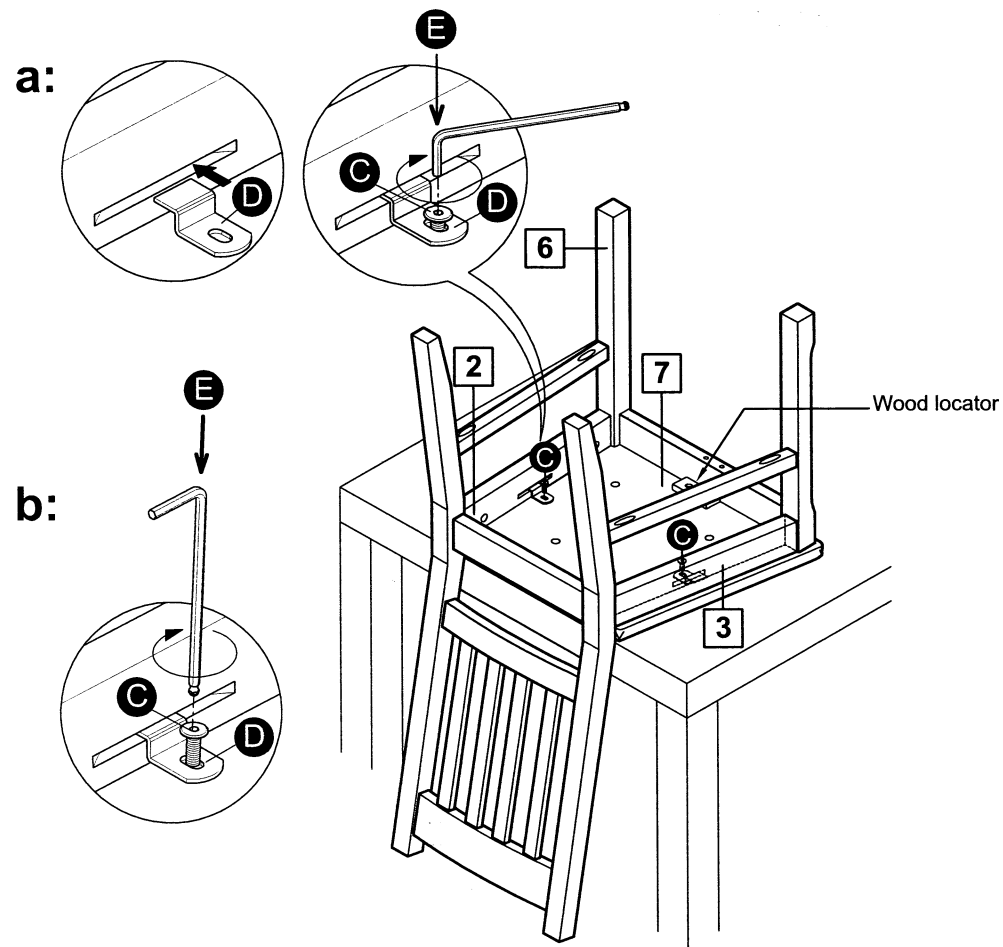

R
12/19/13

MB
18/9/13

Cucina Walnut - Pair of Chairs

Assembly Instructions - Please keep for future reference

603/0720

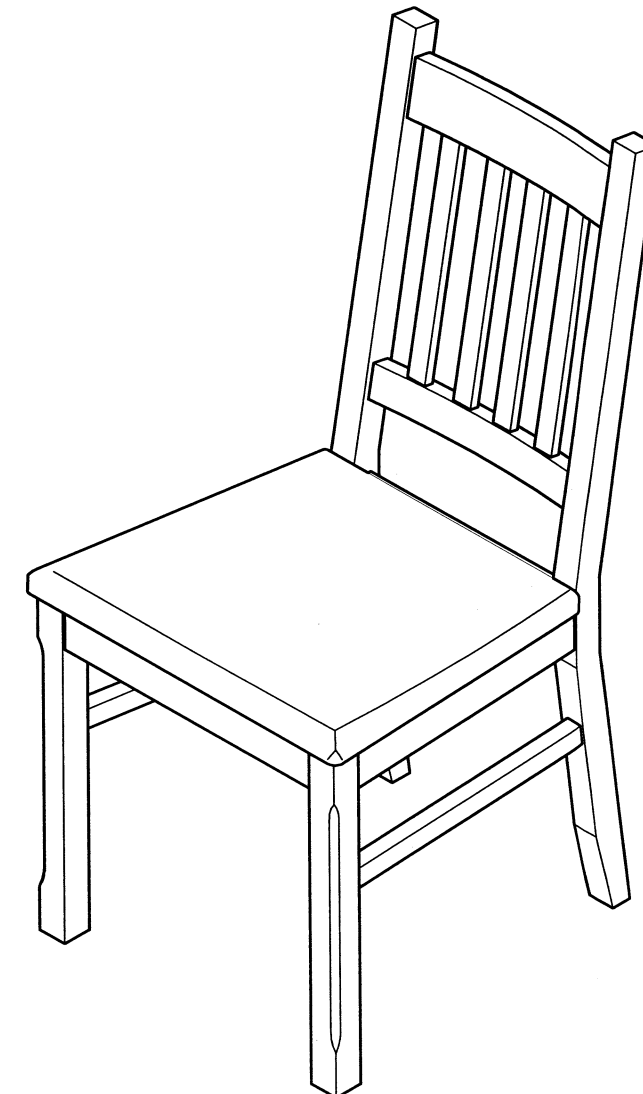

Dimensions

Width - 44cm

Depth - 51.6cm

Height - 92cm

Important - Please read these instructions fully before starting assembly.

If you need help or have damaged or missing parts, call the **Customer Helpline: 08456 400800**

If you need help or have damaged or missing parts, call the **Customer Helpline: 08456 400800**

! Safety and Care Advice

Important - Please read these instructions fully before starting assembly.

- Check you have all the components and tools listed on page 2.

- Remove all fittings from the plastic bags and separate them into their groups.

- Keep children and animals away from the work area, small parts could choke if swallowed.

- Make sure you have enough space to layout the parts before starting.

- Do not stand or put weight on the product, this could cause damage.

- Assemble the item as close to its final position (in the same room) as possible.

- Assemble on a soft flat / firm surface to avoid damaging the unit or your floor.

- Parts of the assembly will be easier with 2 people.

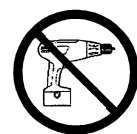

- We do not recommend the use of power drill/ drivers **for inserting screws**,

as this could damage the unit. Only use hand screwdrivers.

- Dispose of all packaging carefully and responsibly.

- The maximum safe weight of user: 110Kg.

Care and maintenance

- Only clean using a damp cloth and mild detergent, do not use bleach or abrasive cleaners.

- From time to time check that there are no loose screws on this unit.

- This product should not be discarded with household waste. Take to your local authority waste disposal centre.

Assembly Instructions

Step 4

Fixing stretchers.

Place chair frame upside down onto a flat, stable, clean and soft surface as shown.

Insert 2 round head screws **B** into pre-drilled holes on stretchers **4**, **5** as shown.

Use a screwdriver to turn round head screws **B** clockwise to fix.

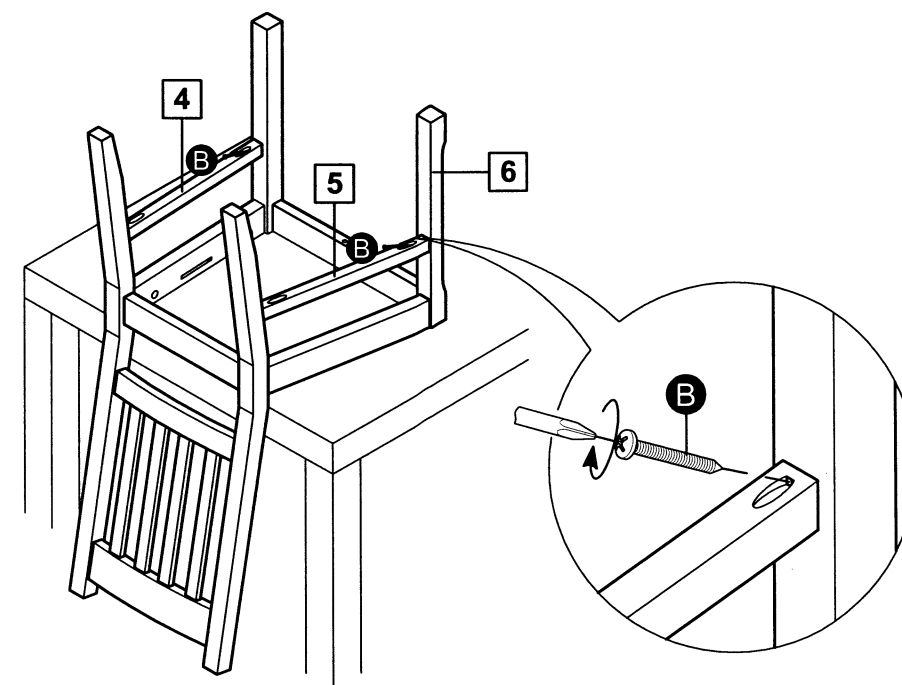

Step 5

Placing seat pad.

a: Lift chair frame up and place seat pad **7** below the chair with wooden locator block positioned as shown.

b: Lower chair frame onto seat pad **7**.

Note: Ensure wooden locator block is inside front leg frame **6** as shown.

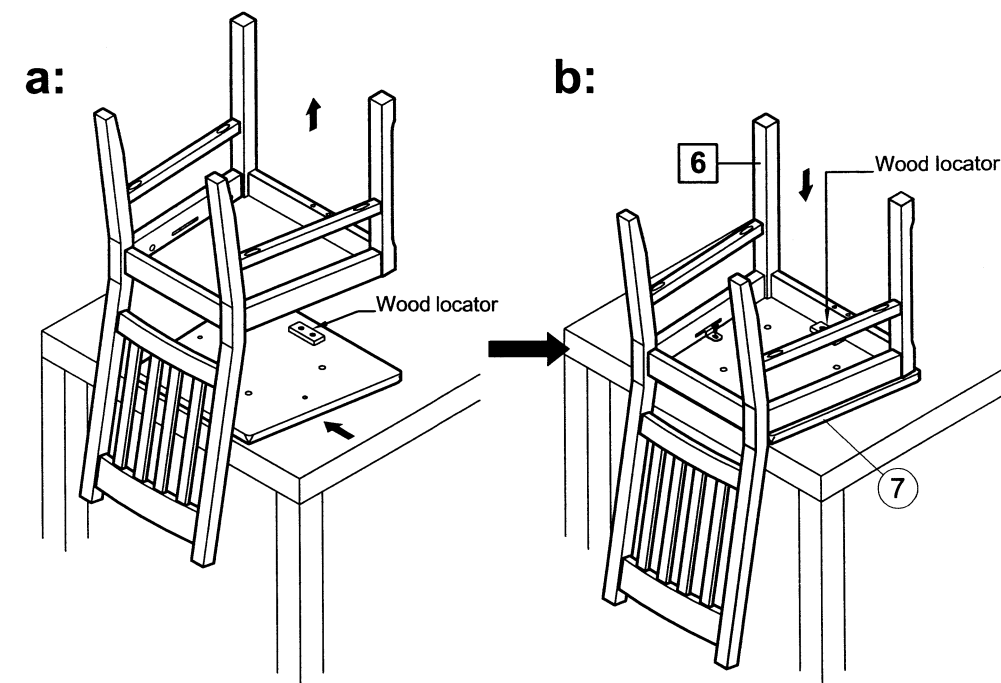

Assembly Instructions

Step 3

Attaching front leg frame.

a: Attach front leg frame **6** onto left & right aprons **2** and **3** as shown.

Note: Ensure steel dowels **A** and wooden dowels are aligned correctly with the mating holes to avoid damage.

Ensure end of aprons **2**, **3** and stretchers **4**, **5** are flush with front leg frame **6**.

b: Secure front leg frame **6** to left & right aprons **2** and **3** using 2 grub screws **F** as shown.

Use large allen key **G** to turn fittings **F** clockwise to fix.

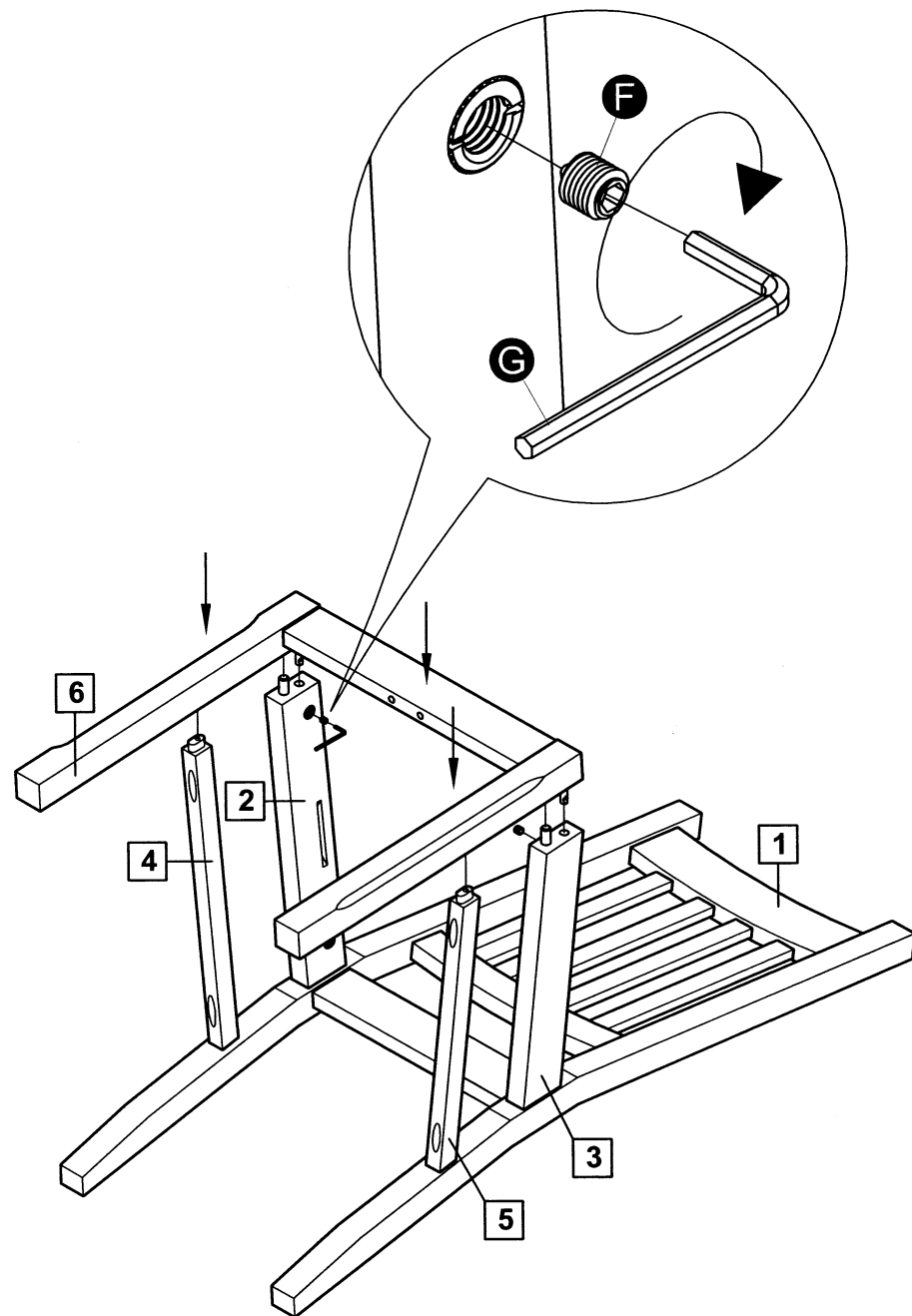

Components - Panels

If you have damaged or missing components, call the Customer Helpline: 08456 400800

Please check you have all the panels listed below.

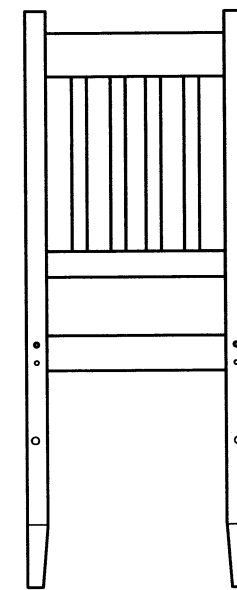

1 Back leg frame x 2
(34.68 x 92cm)

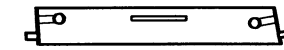

2 Left apron x 2
(37.12 x 5.5cm)

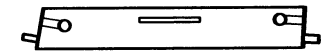

3 Right apron x 2
(37.12 x 5.5cm)

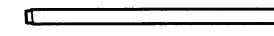

4 Left stretcher x 2
(38.1 x 2.4cm)



5 Right stretcher x 2
(38.1 x 2.4cm)

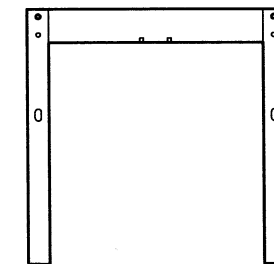

6 Front leg frame x 2
(42 x 42cm)

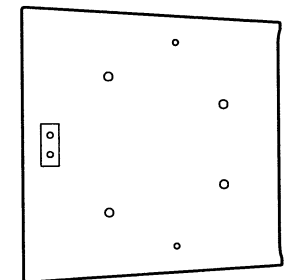





7 Seat pad x 2
(41.5 x 44.2cm)

Components - Fittings

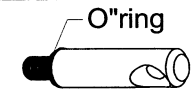
Please check you have all the fittings listed below.

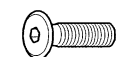
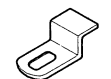
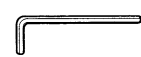
Note: The quantities below are the correct amount to complete the assembly. In some cases more fittings may be supplied than are required.

A  48.5mm Steel dowel x 8	B  50mm Round head screw x 8	C  15mm Hex head bolt x 4	D  Seat bracket x 4
E  Small allen key x 1	F  Grub screw x 8	G  Large allen key x 1	

Tools required

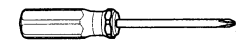
 Phillips screwdriver
(medium & large)

Ruler - Use this ruler to help correctly identify the screws



Assembly Instructions

Step 1

Fitting dowels.

a: Screw 2 steel dowels **A** into back leg frame **1** by screwing fittings **A** into the inset fittings that are located on back leg frame **1** as shown.

Note: Ensure the direction of the holes on fittings **A** are facing correctly as per diagram.

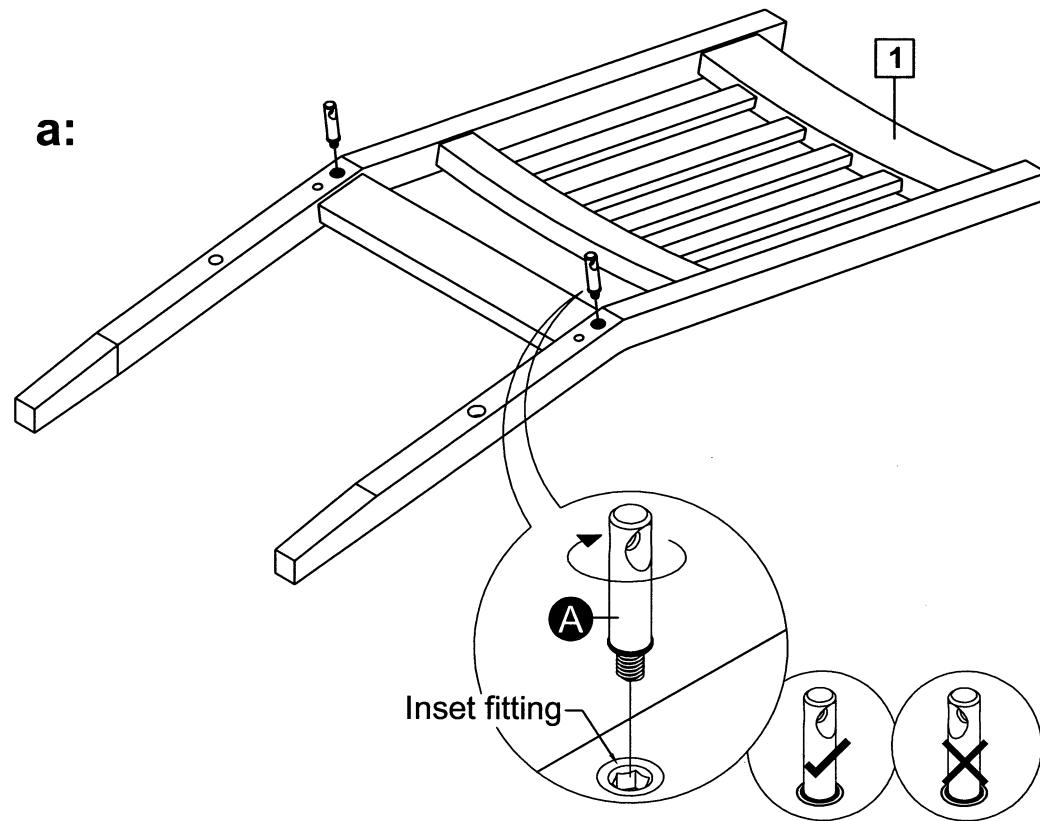

b:

b: Screw 2 steel dowels **A** into front leg frame **6** by screwing fittings **A** into the inset fittings that are located on front leg frame **6** as shown.

Note: Ensure the direction of the holes on fittings **A** are facing correctly as per diagram.

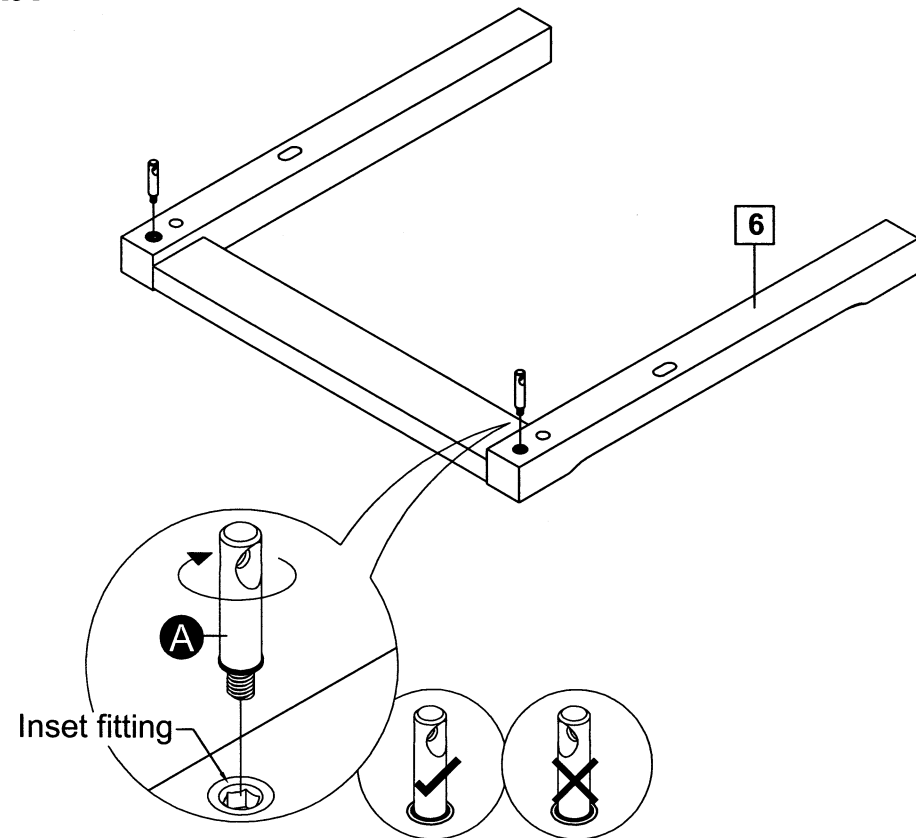

Assembly Instructions

Step 2

Attaching aprons and stretchers

Attach left & right aprons **2** and **3** onto back leg frame **1** as shown.

Note: Ensure steel dowels **A** and wooden dowels are aligned correctly with the mating holes to avoid damage.

Ensure end of aprons **2**, **3** are flush with back leg frame **1**.

Secure aprons **2** and **3** to back leg frame **1** using 2 grub screws **F** as shown.

Use large allen key **G** to turn fittings **F** clockwise to fix.

b: Position left and right stretchers **4**, **5** onto back leg frame **1** as shown.

Ensure end of stretchers are flush with back frame.

Insert 2 round head screws **B** into stretchers **4**, **5** as shown.

Use a screwdriver to turn round head screws **B** clockwise to fix.

Note: Back leg frame **1** has different sized holes for stretchers **4** & **5**.

