

# ALITE

## ACTIVE ASSEMBLY GUIDE

Please read these instructions carefully. Each bike comes with an Owners' Manual that contains a great deal of information and tips, including a comprehensive guide to care and maintenance that we recommend you read carefully.

Our bikes are fully adjusted and checked over at the factory. The handlebars may be removed or assembled in the bike and turned through 90 degrees. The pedals removed and in some cases the front wheel will have been removed too. It is a relatively simple operation to re-assemble these parts, however if you do not feel competent to do this you should ask someone who is, as it is important that these simple tasks are done correctly for the integral safety of the bike.

Please remove all packaging very carefully, especially if using a knife or sharp blade. Take care not to scratch any of the parts of the bike or slash the tyres. We suggest that you keep hold of the carton in case you need to return the bike.

### **Getting Started**

Open the carton from the top and carefully remove the bicycle. Take care not to scratch any of the parts of the bike or cut the tyres. Remove the straps and protective wrapping from the bicycle. Inspect the bicycle, all accessories and parts for possible shortages.

We strongly recommend that the threads and all moving parts in the parts package be lubricated prior to installation. Do not discard packing materials until assembly is complete to ensure that no required parts are accidentally discarded.

## Saddle

Using the supplied flat spanner loosen the seat clamp bolt and insert the seatpost into the seat tube.

Adjust the saddle height to suit the comfort of the rider but ensure the minimum insertion mark on the seat post remains completely within the seat tube.

Tighten the seat clamp bolt to lock the seat in place.

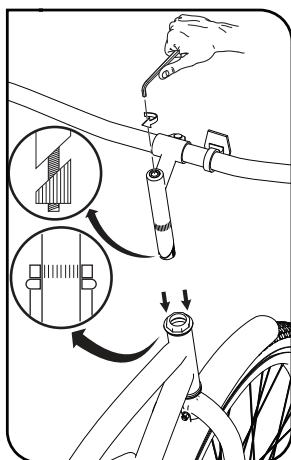
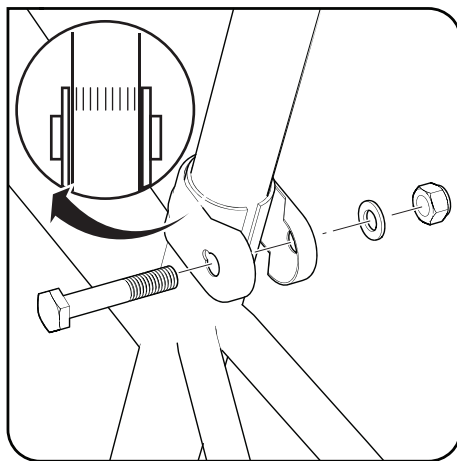

## Handlebars and stem

Rotate the bicycle forks so that the brakes are to the fore.

Remove the protective plastic cap from the end of the handle bar stem.

Insert the end of the stem into the front forks with the stem pointing forwards.

Use the provided hex wrench to tighten the stem bolt just enough to hold the stem in position.

Align the handlebars with the fork legs, ensure the minimum insertion mark is completely within the head tube and then fully tighten the stem bolt.

## Front wheel installation

Squeeze the brake arms (A) together.

Lift the brake cable guide (B) out of the guide bracket (C) to release the brake arms.

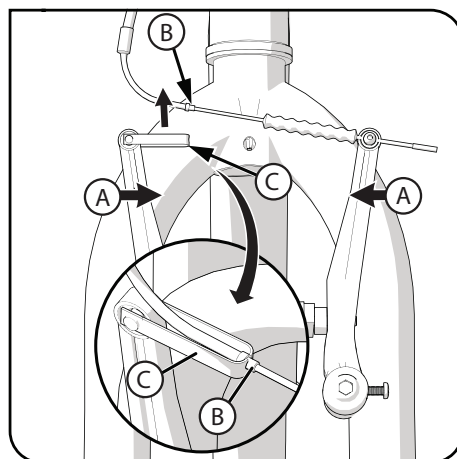

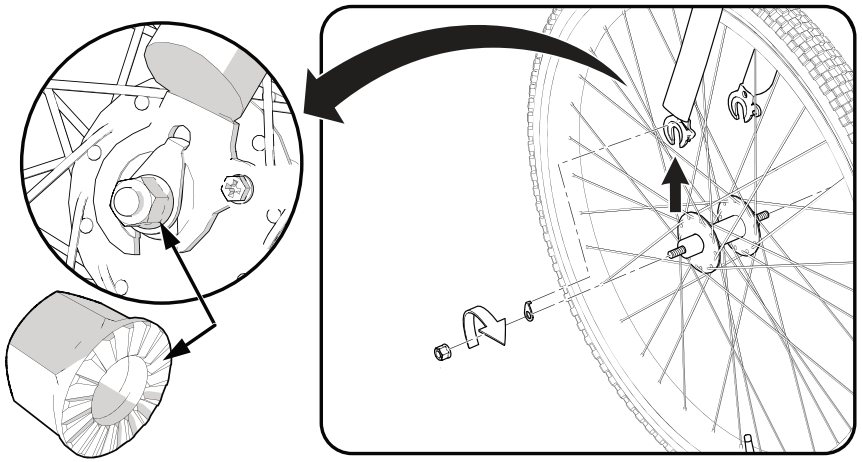

Take the front wheel and loosen the wheel nuts off each end of the axle. Remove the retaining washers from the axle. Note the direction arrow on the tyre side wall and ensuring it points forwards drop the front forks onto the axle. Slide the retaining washers onto the axle and ensure they lock into the forks. Attach and fully tighten the wheel nuts. Lift the front wheel off the ground and give it a spin to ensure it rotates without hinderance and is 'true'.

Squeeze the brake arms (A) together. Drop the brake cable guide (B) into the guide bracket (C) ato engage the brake arms. **Ensure the brake cable guide is securely seated in the guide bracket.**

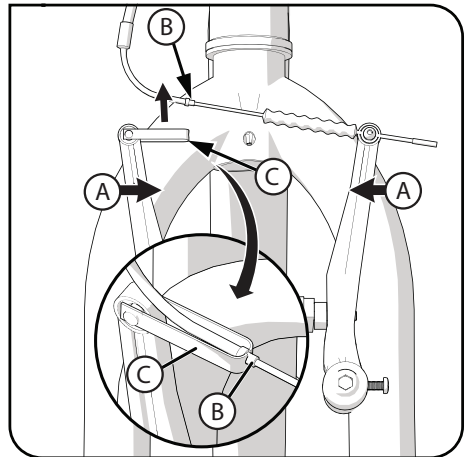

## Pedals

The final step is to attach the pedals.

Your pedals and cranks are specially designed so that they do not unscrew as you pedal.

It is very important that you follow these directions for correct attachment.

Failure to do so can strip the threads from your cranks. This may cause the rider to lose control of the bicycle and fall. Incorrect installation will invalidate your warranty.

The spindle of each pedal is marked with an 'R' or 'L' corresponding to right and left respectively:

Imagine you are seated on the bicycle facing forward: the left pedal should go on the same side as your left foot, similarly for your right pedal and foot.

When attaching the pedals, be aware of the thread direction:

Always attach a pedal by rotating it towards the front wheel. Start by threading the pedal on with your hands. Once it is finger tight, tighten fully with a spanner.

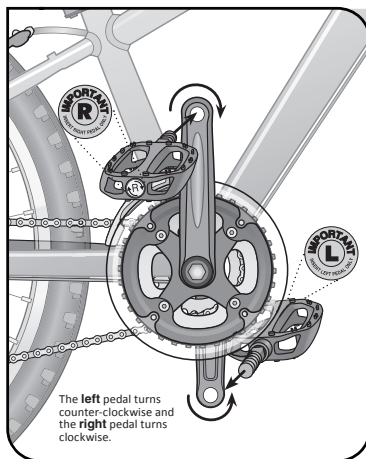

Exclusively distributed throughout the UK by Moore Large & Co. LTD. For assistance, please contact our customer service professionals:



Grampian Buildings, Sinfin Lane Industrial Estate,  
Sinfin Lane, Derby DE24 9GL



01332 274200



[customer.service@moorelarge.co.uk](mailto:customer.service@moorelarge.co.uk)



moorelarge

FLO42T / FLO43T