

Kentucky Chairs

Assembly Instructions - Please keep for future reference

107/8110

121/1173

138/1230

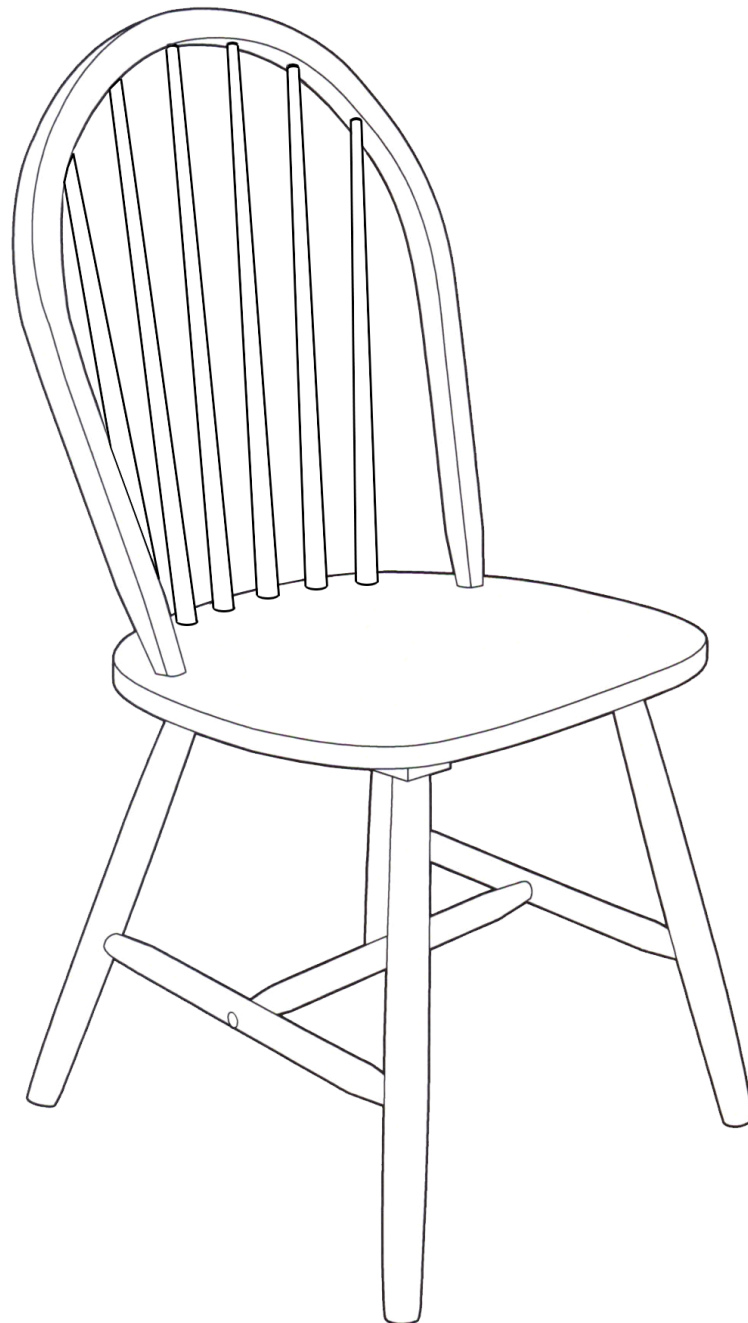

Dimensions

Width - 46cm

Depth - 53.5cm

Height - 93cm

Important - Please read these instructions fully before starting assembly

If you need help or have damaged or missing parts, call the **Customer Helpline: 08456 400800**



Safety and Care Advice

Important – Please read these instructions fully before starting assembly

- Keep these instructions for future use.
- Check you have all the components and tools listed on page 2 and 3.
- Do not stand or put excessive weight on the product, this could cause damage.
- Parts of the assembly will be easier with 2 people.
- Do not use this item if any components are missing or damaged.
- During assembly children should be kept away from the product due to possible risk of injury.
- Remove all fittings from the plastic bags and separate them into their groups.
- Dispose of all packaging carefully and responsibly.
- To ensure an easier assembly, we strongly advise that all fittings are only finger tightened during initial assembly. Only upon completion of the assembly should all fixing points be fully tightened.

Solid wood / Real wood veneers

- This product has been finished using natural materials. As a living material, you may notice some variation in the grain and colour shade between the different components.
- Unlike a synthetic or man-made material which has a uniform finish, a feature of natural wood is its variation in grain and colour. We wish to reassure you that this is quite normal and is not the result of any manufacturing fault.
- Where sheets of wood are joined together, a line may be detected. Again, this is normal and is not an imperfection.
- The natural finish should be cared for by the periodic application of a good quality 'wax' based domestic furniture polish (Not silicone!!). Occasional / small spills should be removed immediately using a damp cloth.
- Do not allow hot articles to come into contact with the surface, as damage will occur!

Care and maintenance

- Clean using a damp cloth or a proprietary domestic furniture polish. Do not use abrasive cleaners.
- This product should not be discarded with household waste. Take to your local authority waste disposal only.
- From time to time check that there are no loose screws on this unit.

Components - Parts

If you have damaged or missing components,
call the **Customer Helpline: 08456 400800**

Please check you have all the parts listed below

Note: Component parts listed below are required for one chair only.

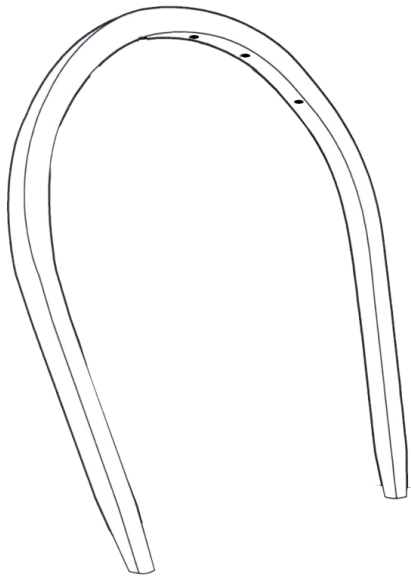

1 Chair Back (45.5 x 53 x 2.5cm)



2 Spindle x 2 (1.7 x 50.3cm)



3 Spindle x 2 (1.7 x 48.5cm)



4 Spindle x 2 (1.7 x 44cm)

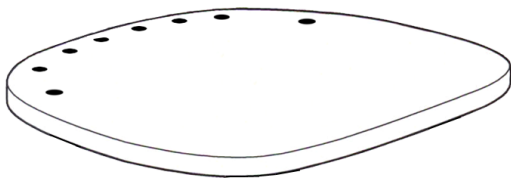

5 Chair Seat (44 x 43 x 2cm)



6 Cross bar(2.8 x 36cm)

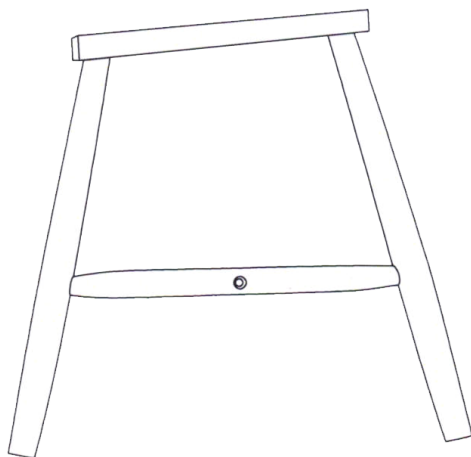

7 Left side frame (44 x 42cm)

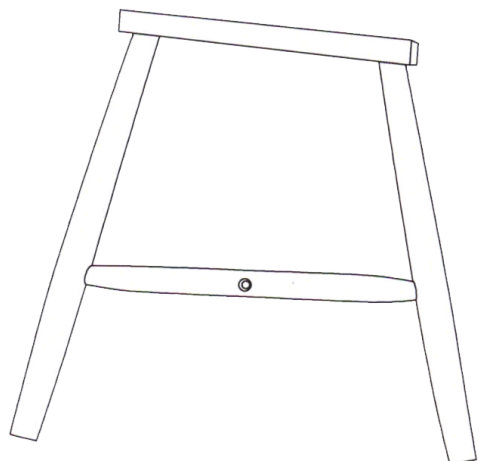







8 Right side frame (44 x 42cm)

Components - Fittings

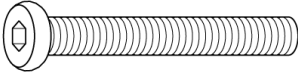
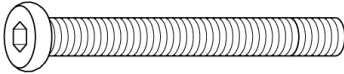
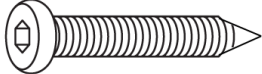
If you have damaged or missing components, call the **Customer Helpline: 08456 400800**

Please check you have all the fittings listed below

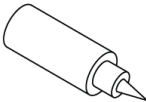
Note: The quantities below are the correct amount to complete the assembly. In some cases more fittings may be supplied than are required.

| | | |
|---|---|---|
| <p>A</p>  <p>50mm Allen screw x 2</p> | <p>B</p>  <p>70mm Allen screw x 2</p> | <p>C</p>  <p>35mm Allen Screw x 6</p> |
| <p>D</p>  <p>Barrel Nut x 4</p> | <p>E</p>  <p>Wood plugs x 2</p> | <p>F</p>  <p>Metal Washer x 2</p> |
| <p>G</p>  <p>Glue x 1</p> | <p>H</p>  <p>Allen key x 1</p> | |

Tools required



Ruler/tape measure

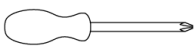

Phillips screwdriver (medium & large)

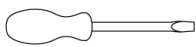

Flatblade screwdriver (medium)

Ruler - Use this ruler to help correctly identify the screws

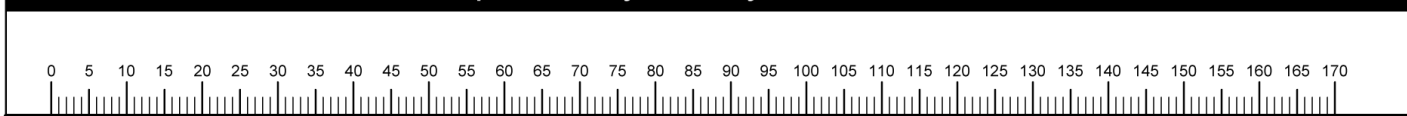

Assembly Instructions

Step 1

Fitting the Side Frames

a: Insert Barrel nuts **D** into Cross bar **6**.

Use screws **A** to fix Cross bars **6** onto the Left side frame **7**.

Note: Insert Barrel nuts into the Cross bar taking care to align the screw holes.

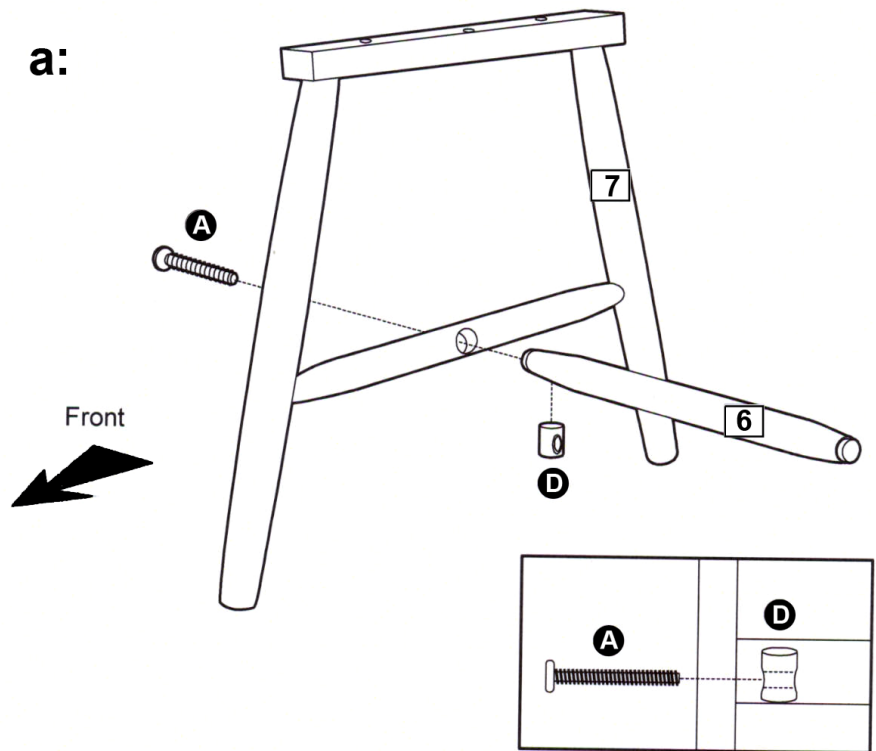

b: Insert Barrel nuts **D** into Cross bar **6**.

Use screws **A** to fix Right side frame **8** onto the unit.

Note: Insert Barrel nuts into the Cross bar taking care to align the screw holes.

Note: Do not fully tighten the screws at this moment.

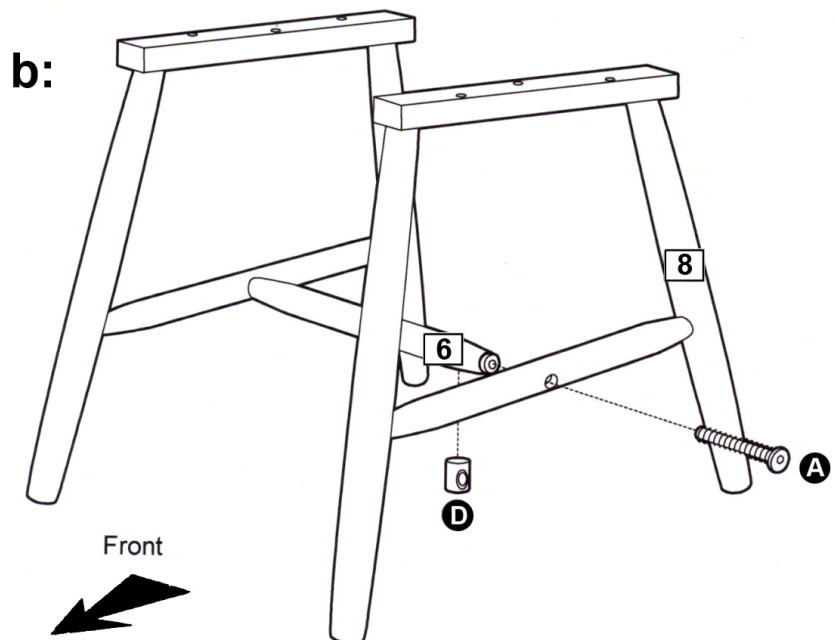

Assembly Instructions

Step 2

Assembling the Back and Seat

a: Liberally apply glue **G** to spindle holes in seatpad **5**.

Locate spindles **2**, **3** and **4** into spindle holes in seatpad **5** as shown.

Note: ensure the widest end of the spindles are located in the holes in seatpad **5**.

Note: wipe away excess surface glue before it dries.

b: Liberally apply glue to holes in chair back **1** and in seatpad **5**.

Carefully locate chair back **1** onto spindles **2**, **3** and **4** and into holes in seatpad **5** as shown.

Note: wipe away excess surface glue before it dries.

c: Holding everything in place, carefully turn the seat assembly upside down onto a clean flat surface.

Insert barrel nuts **D** into chair back **1**.

Note: Insert barrel nuts taking care to align the screw holes.

Use screws **B** and washers **F** to fix chair back **1** to seatpad **5**.

Note: fully tighten screws and wipe away excess glue before it dries.

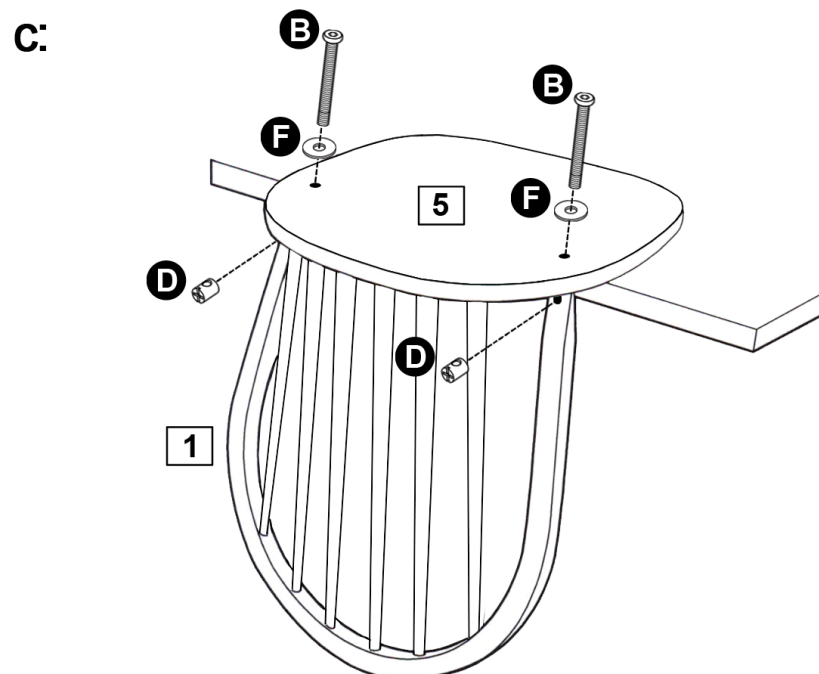
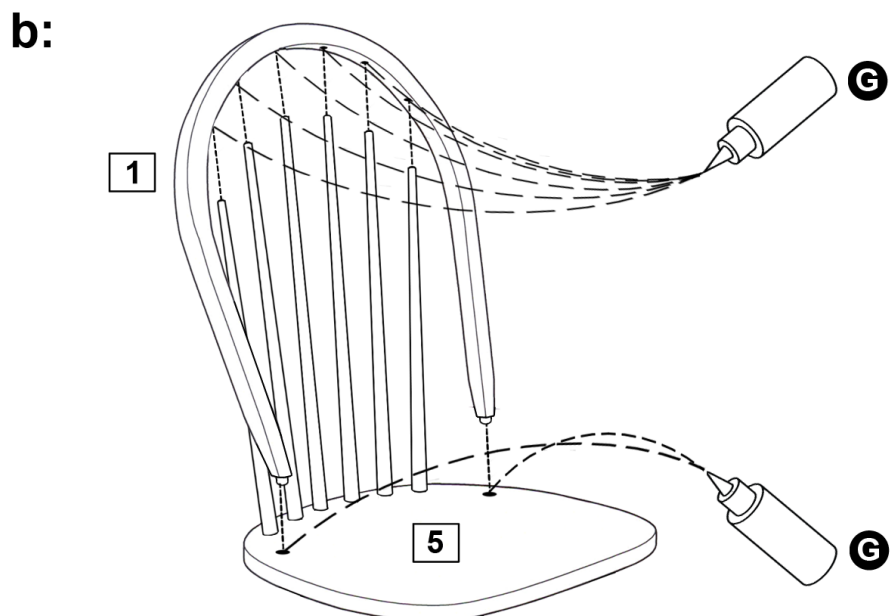
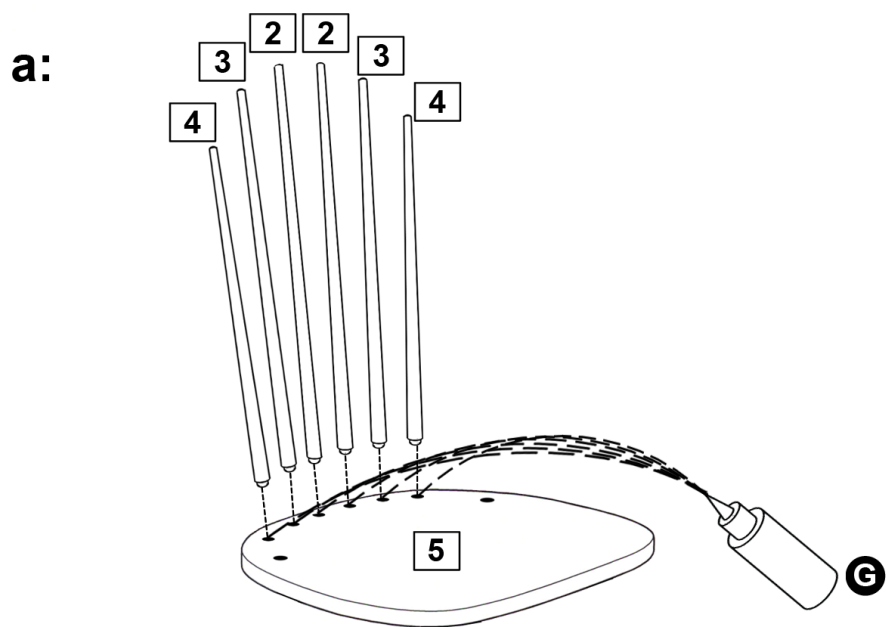

Assembly Instructions

Step 3

Assembling the Chair seat and leg frame.

a: Place Chair seat upside down onto a clean flat surface (edge of table top).

Use screws **C** to fix the Chair seat **5** onto the side frames **7** and **8**.

Note: Ensure the arrows on the under side of Left side frame **7** and Right side frame **8** are pointing towards the front edge of Chair seat **5**.

Fully tighten all screws now.

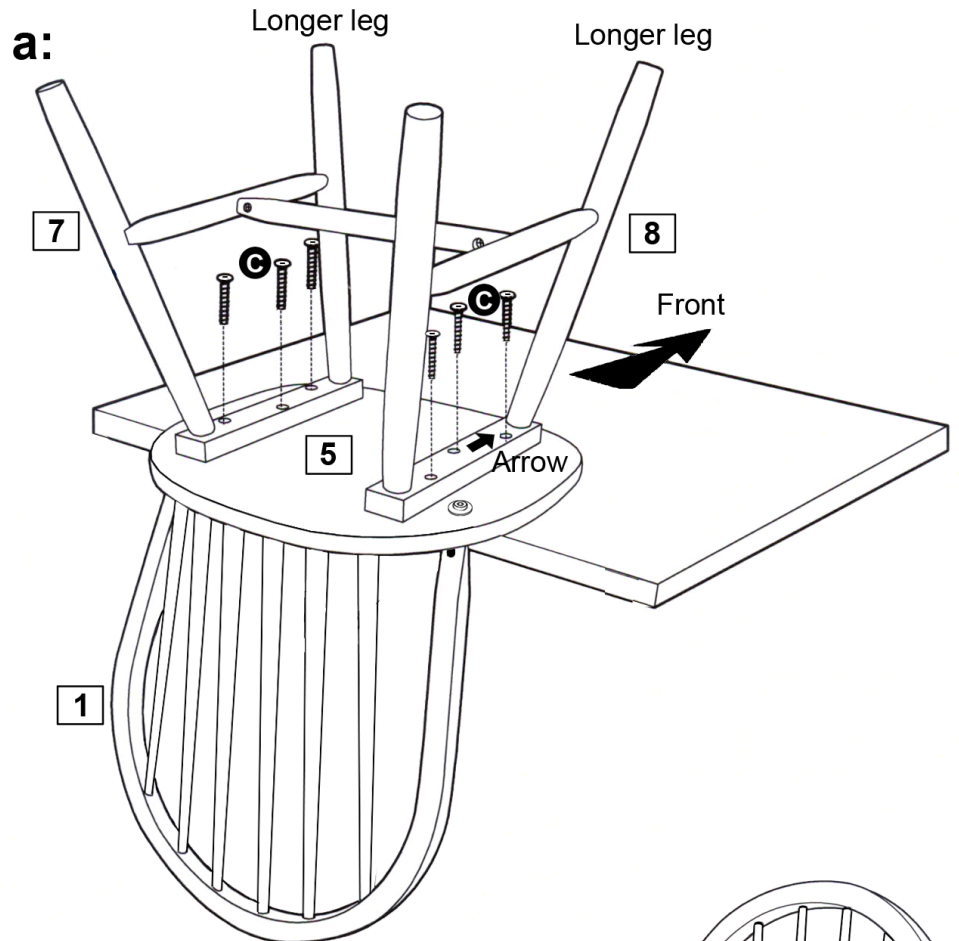

b: Use Wood plugs **E** to cover the screw holes.

Note: Once assembly is complete, please allow 12 hours for glue to dry before using chairs.

