

MICROWAVE OVEN

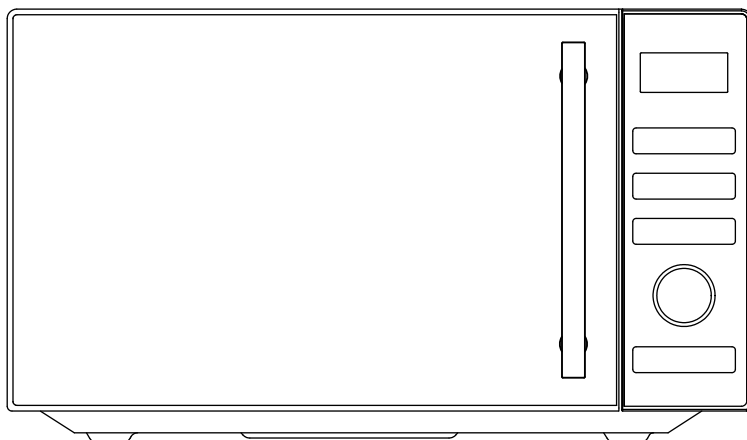

Installation & User Instructions – Please keep for future reference

702/2232



Important

- **WARNING** : if the door or door seals are damaged, the oven must not be operated until it has been repaired by a competent person;
- **WARNING** : it is hazardous for anyone other than a competent person to carry out any service or repair operation that involves the removal of a cover which gives protection against exposure to microwave energy;
- **WARNING** : liquids and other food must not be heated in a sealed container since they are liable to explode;
- **WARNING** : accessible parts may become hot during. Young children should be kept away.

Contents

Safety Information	2
Material you can use in microwave oven	9
Material to avoid using in the microwave oven	9
Utensils	10
Setting up your oven	11
Oven components and accessories	11
Turntable installation	11
Microwave cooking principle	12
Microwave food packaging symbols	12
Accessories included	12
Installation	13
Please note Electrical connection	13
Earthing Installation	14
Operating your microwave oven	15
Control Panel	15
Setting the Clock	16
Microwave Cooking	16
Grill Cooking	18
Micro+Grill Cooking	18
Convection cooking	19
Auto Cook	22
Cleaning your microwave oven	27
Troubleshooting and maintenance	28
Troubleshooting and maintenance	28
Troubleshooting	29
Questions and Answers	30
Technical Specifications	31
Disposal information	
Guarantee	

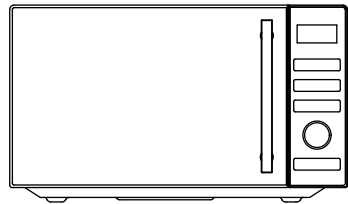

Product Codes

D90D25ESLR.III-ZWB



Safety Information

Important – Please read these instructions fully before installation

IMPORTANT SAFETY INSTRUCTIONS

READ CAREFULLY AND KEEP FOR FUTURE REFERENCE

1. The temperature of accessible surfaces may get hot when the appliance is operating especially the metal top area and the warming rack if any.
2. This appliance can be used by children aged from 8 years and above and persons with reduced physical, sensory or mental capabilities or lack of experience and knowledge if they have been given supervision or instruction concerning use of the appliance in a safe way and understand the hazards involved. Children shall not play with the appliance. Cleaning and user maintenance shall not be made by children unless they are older than 8 and supervised.
3. The appliance is not intended to be operated by means of an external timer or separate remote-control system.
4. The appliance is intended to be used in household not for commercial use and similar applications such as :
 - staff kitchen areas in shops, offices and other working environment;
 - by clients in hotels, motels and other residential type environments;
 - farm houses;
 - bed and breakfast type environments.
5. **WARNING:** If the door or door seals are damaged, the oven must not be operated until it has been repaired by a competent person.
6. **WARNING:** It is hazardous for anyone other than a competent person to carry out any service or repair operation that involves the removal of a cover which gives protection against exposure to microwave energy.
7. **WARNING:** Liquids and other foods must not be heated in sealed containers since they are liable to explode.
8. A minimum clearance of 12 inches (30cm) must be left above the top of the oven.



Safety Information

Important – Please read these instructions fully before installation

9. Only use utensils that are suitable for use in microwave ovens.
10. When heating food in plastic or paper containers, keep an eye on the oven due to the possibility of ignition.
11. The microwave oven is intended for heating food and beverages. Drying of food or clothing and heating of warming pads, slippers, sponges, damp cloth and similar may lead to risk of injury, ignition or fire.
12. If smoke is observed, press the “Stop” button and leave the door closed in order to stifle any flames. Disconnect the power cord, and / or shut off power at the fuse or circuit breaker panel.”
13. Microwave heating of beverages can result in delayed eruptive boiling, therefore care must be taken when handling the container.
14. The contents of feeding bottles and baby food jars shall be stirred or shaken and the temperature checked before consumption, in order to avoid burns.
15. Eggs in their shell and whole hard-boiled eggs should not be heated in microwave ovens since they may explode, even after microwave heating has ended. Pierce foods with heavy skins such as potatoes, squashes, apples and chestnuts before cooking.
16. The oven should be cleaned regularly and any food deposits removed.
17. When cleaning door and oven surfaces use only mild, non-abrasive soaps or detergents applied with a sponge or soft cloth.
18. Failure to maintain the oven in a clean condition could lead to deterioration of the surface which could adversely affect the life of the appliance and possibly result in a hazardous situation.
19. The microwave oven shall not be placed in a cabinet.



Safety Information

Important – Please read these instructions fully before installation

20. The rear surface of appliances shall be placed against the wall. This appliance incorporates an earth connection for functional purposes only.
21. **WARNING** : The appliance and its accessible parts become hot during use. Care must be taken to avoid touching heating elements. Children less than 8 years of age shall be kept away unless continuously supervised. Warning: When the appliance is operated in the combination mode, children should only use the oven under adult supervision due to the temperatures generated.
22. Do not use harsh abrasive cleaners or sharp metal scrapers to clean the oven doorglass since they can scratch the surface, which may result in shattering of the glass.
23. Do not use steam cleaners inside the cavity. Caution! Steam will escape, when opening lids or wrapping foil.
24. The Oven must be placed on a level surface.
25. The turntable and turntable ring assembly must always be used in the oven during cooking. Place the cookware gently on the turntable and handle it carefully to avoid possible breakage.
26. Incorrect use of dish for browning food may cause turntable to break.
27. Use only the specified bag size when using pre-prepared popcorn.
28. The Oven has several built-in safety switches to ensure that the power remains off when the door is open. Do not tamper with these switches.
29. Do not operate the microwave oven when empty. Operating the oven with no food or food that is extremely low in moisture can cause fire, charring or sparking.
30. Do not cook bacon directly on the turntable. Excessive local heating of the turntable may cause the turntable to break.



Safety Information

Important – Please read these instructions fully before installation

31. Do not heat narrow-necked containers, such as syrup or sauce bottles.
32. Do not attempt to deep-fry in your microwave oven. Hot oil can damage oven parts and utensils and even result in skin burns.
33. Do not attempt home canning in this microwave oven as it is impossible to be sure all contents of the jar have reached boiling temperature.
34. Caution: Stir the liquid prior to and during heating/reheating, let liquid stand for a least 10 seconds after cooking and always take care when add in ingredients to hot liquids. Microwave heating of beverages can result in delayed eruptive boiling, therefore care must be taken when handling the container.
35. Check the food in the microwave oven frequently to avoid burning due to overheating.
36. Stand at arm's length when opening the door to avoid scalding when steam or hot air is released. The oven has switched off according to the food being cooked to allow heat to distribute evenly throughout the food.
37. Always allow an appropriate standing time after the oven has switched off according to the food being cooked to allow heat to distribute evenly throughout the food.
38. Use oven gloves when removing any cookware from oven to reduce chance of being burned or scalded. Cooking utensils may become hot because of heat transferred from the heated food. Pot holders may be needed to handle the utensil.
39. Read and follow the specific: "Precaution for avoiding possible exposure to excessive microwave energy".
40. As with most cooking appliances, close supervision is necessary to reduce the risk of a fire in the oven cavity. This microwave oven is intended for heating food and beverages. Drying of food or clothing and heating of warming pads, slippers, sponges, damp cloths and similar may lead to risk of injury, ignition or fire.



Safety Information

Important – Please read these instructions fully before installation

41. Do not overcook food. Regularly observe the oven if paper, plastic, or other combustible materials are used in the oven. The microwave oven is intended for defrosting, cooking and steaming of food only.
42. Do not use the oven cavity for storage purposes. Do not leave paper product, cooking utensils or food in the cavity when not in use.
43. Remove wire twist-ties and metal handles from paper or plastic containers/bags before placing them in the oven.
44. This oven must be earthed. Connect only to properly earthed outlet. See "earthing installation".
45. Install or locate this oven in accordance with the installation instructions provided.
Warning: Do not install oven over a range cooktop or other heat-producing appliance. If installed could be damaged and the warranty would be void.
46. Use this appliance only for its intended uses as described in the manual. Do not use corrosive chemicals or vapours in the appliance. This Oven is specifically designed to heat or cook food. It is not designed for industrial or laboratory use.
47. If the supply cord or plug is damaged, or if the oven is not working properly or has been dropped it must be replaced or repaired by the manufacturer or its service agent or a similarly qualified person in order to avoid hazard.
48. This appliance should be serviced only by qualified service technicians. Contact the nearest authorised service facility for examination, repair or adjustment.
49. Do not cover or block any vents on the oven.
50. Do not store or use this appliance outdoors.



Safety Information

Important – Please read these instructions fully before installation

51. Do not use this oven near water, near a kitchen sink, in a wet basement or near a swimming pool.
52. Do not immerse cord or plug in water.
53. Keep cord away from heated surfaces.
54. Do not let cord hang over edge of table or counter.
55. Do not attempt to repair the oven yourself, please consult an authorised service agent.
56. Do not attempt to operate this oven with the door open since open-door operation can result in harmful exposure to microwave energy. It is important not to try and override or tamper with the safety interlocks.
57. Do not operate the oven if it is damaged. It is particularly important that the oven door closes properly and that there is no damage to the, (1) door (i.e. door is not bent or dented), (2) hinges and latches (broken or loosened), (3) door seals and sealing surfaces.
58. Utensils should be checked to ensure that they are suitable for use in microwave ovens.
59. The  symbol on the product or on its packaging indicates that this product may not be treated as household waste. Instead it shall be handed over to the applicable collection point for the recycling of electrical and electronic equipment. By ensuring this product is disposed of correctly, you will help prevent potential negative consequences for the environment and human health, which could otherwise be caused by inappropriate waste handling of this product. For more detailed information about recycling of this product please contact your local city office, your household waste disposal service or the shop where you purchased the product.
60. The lamp holder must be serviced by an authorized service agent. Never remove the distance holder in the back or on the sides, as it ensures a minimum distance from the wall for air circulation.



Safety Information

Important – Please read these instructions fully before installation

61. During use the appliance becomes hot. Care should be taken to avoid touching heating elements inside the oven.
62. The product is classified as a Group 2, Class B, ISM appliance. Group 2 includes all ISM (Industrial, Scientific or Medical) appliances in which radio frequencies are generated intentionally and/or used in the form of electromagnetic radiation to treat materials, together with electroerosion equipment. Class B includes equipment for domestic use or on premises directly connected to low voltage electricity supply for supplying buildings for residential use.
63. This appliance complies with EC directive 2014/30/EU on electromagnetic compatibility and European regulation no. 1935/2004 of 27/10/2004 on food contact materials.

Materials you can use in microwave oven

Utensils	Remarks
Aluminum foil	Shielding only. Small smooth pieces can be used to cover thin parts of meat or poultry to prevent overcooking
Arcing can occur if foil is too close to oven walls.	The foil should be a least 1 inch (2.5cm) away from oven walls.
Browning dish	Follow manufacturer's instructions. The bottom of browning dish must be at least 3/16 inch (5mm) above the turntable. Incorrect usage cause the turntable to break
Dinnerware	Microwave-safe only. Follow manufacturer's instructions. Do not use cracked or chipped dishes.
Glass jars	Always remove lid. Use only to heat food until just warm. Most glass jars are not heat resistant and may break
Glassware	Heat-resistant oven glassware only. Make sure there is no metallic trim. Do not use cracked or chipped dishes.
Oven cooking bags	Follow manufacturer's instructions. Do not close with metal tie. Make slits to allow steam to escape.
Paper plates and cups	Use for short-term cooking/warming only. Do not leave oven unattended while cooking.
Paper towels	Use to cover food for reheating and absorbing fat. Use with supervision for short-term cooking only.
Parchment paper	Use as a cover to prevent splattering and retain moisture
Plastic	Microwave-safe only. Follow the manufacturer's instructions. Should be labelled "Microwave Safe". Some plastic containers soften as the food inside gets hot. "Boiling bags" and tightly closed plastic bags should be slit, pierced or vented as directed by package.
Plastic wrap	Microwave-safe only. Use to cover food during cooking to retain moisture. Do not allow plastic wrap to touch food.
Thermometers	Microwave-safe only (meat and sugar thermometers)
Wax paper	Use as a cover to prevent splattering or as a wrap during steaming.

Materials to avoid using in the microwave oven

Utensils	Remarks
Aluminum tray	May cause arcing. Transfer food into microwave-safe dish.
Food carton with metal handle	May cause arcing. Transfer food into microwave-safe dish.
Metal or metal-trimmed utensils	Metal shields the food from microwave energy. Metal trim may cause arcing.
Metal twist ties	May cause arcing and could cause a fire in the oven.
Paper bags	May cause a fire in the oven
Plastic foam	Expanded polystyrene may melt or contaminate the liquid inside when exposed to high temperature.
Wood	Wood will dry out when used in the microwave oven and may split or crack.

Utensils

CAUTION

Personal Injury Hazard

Tightly-closed containers could explode. Closed containers should be opened and plastic pouches pierced before cooking. See above for further instructions "Materials you can use in microwave oven or to be avoided in microwave oven." There may be certain non-metallic utensils that are not safe to use for microwaving. If in doubt, you can test the utensil in question by following the procedure below.

Utensil test:

1. Fill a microwave-safe container with 1 cup of cold water (250ml) along with the utensil in question.
2. Cook on maximum power for 1 minute.
3. Carefully feel the utensil. If the utensil is warm, do not use it for microwave cooking.
4. Do not exceed 1 minute cooking time.

Setting Up Your Oven

Please familiarize yourself with the parts and accessories listed below

Note : Remove the oven and all the material from the carton

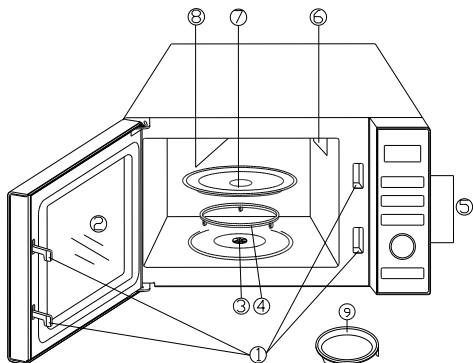

1. Door Safety Lock System
2. Oven Window
3. Shaft
4. Turntable Roller
5. Control Panel
6. Wave Guide
7. Glass Turntable
8. Grill Heater
9. Baking Plate

Turntable Installation

(A) Turntable roller (4), To be placed in the centre of the oven to support the glass plate.

(B) Glass turntable (7), To be placed on the turntable roller.

a. Never place the glass turntable (7) upside down. The turntable should never be restricted in movement.

b. Both glass turntable (7) and turntable roller (4) must always be used during cooking.

c. All food and containers of food should always be placed on the glass turntable for cooking.

d. The glass turntable rotates clockwise or anti-clockwise randomly, this is normal.

e. If glass turntable or turntable roller cracks or breaks, contact your nearest authorized service centre.

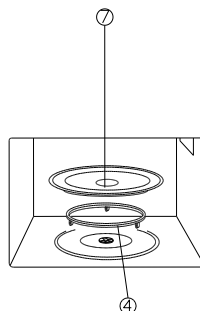

Warning: Do not remove the wave guide (6) that is attached to the oven cavity to protect the magnetron.

Setting Up Your Oven

If you have damaged or missing parts, call the customer helpline : **0345 640 3030**

Microwave Cooking Principles

1. This microwave generated by the magnetron are evenly distributed through the food as the glass turntable revolves. This ensures that the food is cooked uniformly.
2. The microwaves are absorbed by the food up to a depth of approximately 1 inch (2.5cm). Cooking continues as the heat is dissipated through the food.
3. Cooking times will vary according to the recipe and the density, weight and water content of the food. The cooking time will also vary according to the temperature at the start cooking, i.e. depending on whether the food is frozen or not.

Microwave Food Packaging Symbols

Microwave Symbols :

On the front of your oven there is a microwave symbol, as shown below. This symbol has been introduced for your benefit when cooking or reheating packaged food.

Packaged food is also increasingly using a microwave symbol similar to the one below.

When you see this symbol on food packaging the cooking instructions are based on either IEC Power Output Rating, on the Reheating Categories A,B,C,D or E.

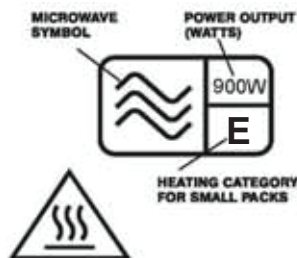

A, B, C, D or E

MORE HEATING TIME

LESS HEATING TIME

Accessories included

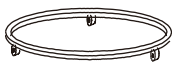

Turntable Roller



Glass Turntable

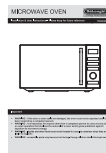

Instruction



Baking Plate



Recipe×2

Installation

Please note Electrical connection

This oven is fitted with a plug and must be only connected to a properly installed earthed socket. In accordance with the appropriate regulation, the socket must only be installed and the connecting cable must only be replaced by a qualified electrician. If the plug is no longer accessible following installation and all-pole isolating switch must be present on the installation side with a contact gap of at least 3mm.

1. Select a level surface that provide enough open space for the intake and / or outlet vents.

A minimum clearance of 3.0 inches (7.5cm) is required between the oven and any adjacent walls. One side must be open.

(1) Leave a minimum clearance of 12 inches (30cm) above the oven.

(2) Do not remove the legs from the bottom of the oven.

(3) Blocking the intake and/or outlet openings can damage the oven.

(4) Place the oven as far away from radios and TV as possible. Operation of microwave oven may cause interference to your radio or TV reception.

2. Plug your oven into a standard household outlet. Besure the voltage and the frequency is the same as the voltage and the frequency on the rating label.

WARNING : Do not install oven over a range cooktop or other heat-producing appliance. If installed near or over a heat source, the oven could be damaged and the warranty would be void.

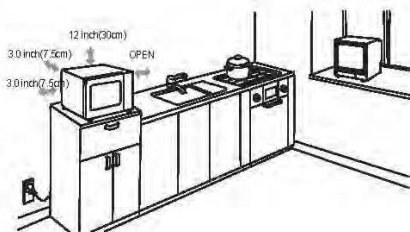

Installation

Electrical connection



Any electrical work that is required to install this appliance **MUST** be carried out by a qualified electrician.



Warning: THIS APPLIANCE MUST BE EARTHED

Before making any electrical connections, ensure that:

- Electrical safety is only guaranteed when the earth system of your house is in accordance with the related local regulations.
- Do not damage the refrigerant circuit.
- Do not bend, stretch or pull the supply cable to avoid electric shock.
- Do not use electrical appliances inside the food storage compartments of the appliance, unless they are of the type recommended by the manufacturer.
- Ensure the power socket is suitable for the maximum power of the washing machine (fuses in the power circuit must be 13 amp).
- The supply voltage should be the same as that indicated in the technical specifications and the appliance rating plate.
- The appliance should be earthed and in compliance with the applicable law.
- When installed, the power socket must be within easy reach.
- If the socket outlets in your home are not suitable for the plug supplied with this unit check with a qualified electrician for replacement.
- The use of adapters, multiple connectors or extension cables are not recommended.
- The appliance must be connected to a 220-240 volt 50Hz AC supply by means of a three pin socket, suitably earthed and protected by a 13 amp fuse.
- Should the fuse need to be replaced, a 13 amp fuse approved to BS1362 must be used.
- The plug contains a removable fuse cover that must be refitted when the fuse is replaced. If the fuse cover is lost or damaged, the plug must not be used until a replacement cover has been fitted or the plug is replaced.
- A damaged plug should be cut off as close to the plug body as possible, the fuse should be removed and the plug disposed of safely.

Plug replacement (UK & Ireland only)

Should you need to replace the plug; the wires in the power cable are coloured in the following way:

Blue – Neutral 'N'

Brown – Live 'L'

Green & Yellow – Earth 'E'

As the colours of the wires in the power cable may not correspond with the coloured markings identifying the terminals in your plug, and proceed as follows:

The green & yellow wire must be connected to the terminal in the plug that is marked with the letter E or by the earth symbol.

The blue wire must be connected to the terminal that is marked with the letter N.

The brown wire must be connected to the terminal that is marked with the letter L.

If power supply cord is damaged, it must be replaced by the manufacturer or its service agent or a similar qualified person in order to avoid a hazard.

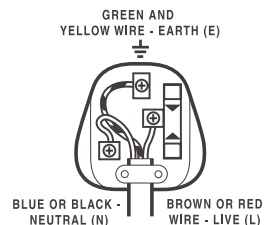

DANGER
Electric
Shock Risk

Operating Your Microwave Oven

Control Panel

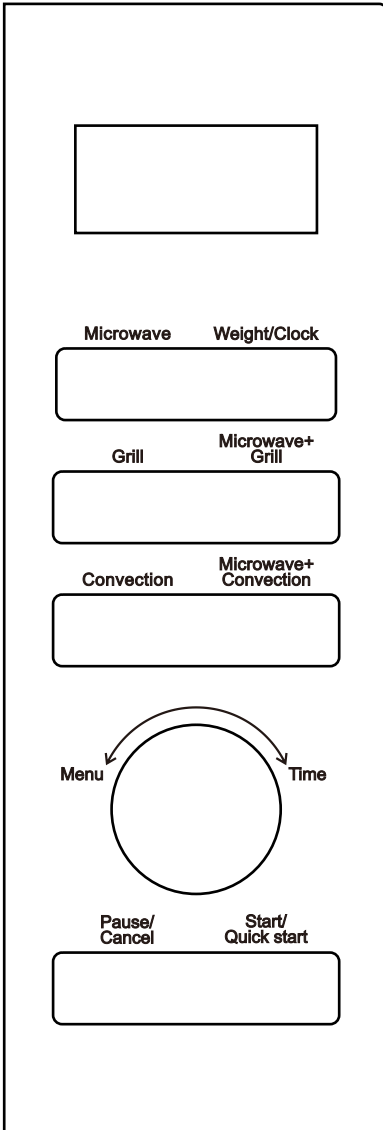

Display Screen

Cooking time, power, indicators and present time are displayed.

Microwave

Press to select microwave Power.

Weight/Clock

Press to set the clock or to set food weight.

Grill

Press to set grill program.

Microwave+Grill

Press to set a grill cooking program or to select one of two combination cooking settings.

Convection

Press to program convection temperature.

Microwave+Convection

Press to select one of four combination cooking settings.

Start/Quick Start

Press to start cooking program or set quick start cooking program.

Pause/Cancel

Touch to stop cooking program or clear all previous settings before cooking starts.





Menu/Time (dial)

Rotate to set cooking time or select auto-menu.















Operating Your Microwave Oven

Setting the Clock Cooking

Your microwave oven is equipped with a clock, you must set the clock when you first install your oven or after a power failure. The system clock can be set in 12 hour cycle clock or 24 hour cycle clock.

1. In standby mode, press  button once to select 24 hr clock or press one more time to select 12 hr clock.
2. Turn  to adjust the hour.
3. After finished setting the hour, Press  once to confirm and go into setting the minute.
4. Turn  to adjust the minute.
5. Finally, press  to confirm the time and the time will be set.

For example: Set the current time to 8:30.





1. Press  twice and it will display "Hr12" and   is flashing.
2. Continue to turn  until it displays "8: ".   is flashing.
3. Press  once again, it displays " :00",   is flashing.
4. Continue to turn  until it displays " :30"   is flashing.
5. Press  once to confirm the time and the screen will show "8:30" and 

Note: You can press the  button once to check clock time during cooking.





Microwave Cooking

To cook with microwave, time and power level should be set. The maximum cooking time is 95min.

You can press  during cooking to check cooking power level.

1. Press  to select the microwave cooking and the display shows "100% 
2. Continue to press  to select the required microwave power level until the required power setting is reached.
3. Turn  to adjust the cooking time until the required time is reached.
4. Press  start the cooking.

Example: Setting cooking time of 20 minutes on power 80%

1. Press  button 2 times and the display shows 80% 
2. Turn  to adjust the cooking time to 20:00.
3. Press  to start cooking.

When the cooking is finished, the oven will display **End** and beep every two minutes until the oven door is opened or  button is ressed.

Noted : The cooking time can be adjusted in the following increments:







0 -- 5 min : 10 sec

5 -- 10 min : 30 sec

10 -- 30 min : 1 min

30 -- 95 min : 5 min

Microwave power chart

No. of times to press  button	Microwave Power Level	Display
once	100%	100% 
twice	80%	80% 
3 times	60%	60% 
4 times	40%	40% 
5 times	20%	20% 
6 times	00%	00% 

Warning: always remember that cooking instructions are intended only as a guide. If you have followed the instructions and the food is still not piping hot throughout, simply return it to the oven and cook It until it is.

Operating Your Microwave Oven

Grill Cooking



This function allows food to be cooked and grilled for the browning at the same time, and Grill cooking is particularly useful for thin slices of meat, steaks, chops, kebabs, sausages or piece of chicken. It is also suitable for hot sandwiches and au gratin dishes. The maximum cooking time is 95 minutes. A baking plate  should be used for cooking.



1. Press  button to select Grill cooking and LED displays 0:10 

2. Turn  in clockwise direction to adjust the cooking time.

3. Press  to start the cooking.

Example : To broil the food for 12 minutes.

1. Press  button once and the LED displays 0:10 

2. Continue to turn  in clockwise direction until the LED displays "12:00". 



3. Press  to start the cooking.

NOTE: When the cooking is finished, the oven will display **End** and beep every two minutes until the oven door is opened or  button is pressed.

Microwave+Grill Cooking

The function allows the food to be cooked and grilled for browning at the same time. Always use microwave-safe and Oven-proof cookware. Glass or ceramic dishes are ideal as they allow the microwaves to penetrate the food evenly, Always use gloves when touching the cookware in the oven, as they will be very hot. The longest cooking time you can set is 95 minutes.

1. Press  once or twice to choose the desire combination setting, i.e. CO-1 or CO-2.

No. of time to press  Button	Display	Microwave Cooking Time	Grill Cooking Time	Cycle(sec.)
once	Co-1 	30%	70%	33
Twice	Co-2 	55%	45%	33

2. Turn  clockwise to adjust the cooking time.

3. Press  to start the cooking.

Example: set the oven to micro+grill cooking for 25 Minutes under Combi.1 setting.

1. Press  once to select CO-1.

2. Continue to turn  clockwise until the LED displays 25:00.

3. Press  to start cooking.





NOTE: When the cooking is finished, the oven will display **End** and beep every two minutes until the oven door is opened or  button is pressed.

Operating Your Microwave Oven





Convection cooking

The convection cooking can let you cook the food as a traditional oven with hot air circulation throughout the oven cavity to brown and make crisp foods quickly and evenly. Microwave is not used. You can set the temperature from 110 °C to 200 °C. It is recommended that you should pre-heat the oven to the appropriate temperature before placing the food in the oven. The maximum cooking time is 95:00. You can press  during cooking to check cooking temperature.

To Cook with Convection without preheat







1. Press  button once and the LED will display  and "200°C".
2. Continually press  to select cooking temperature.
3. Turn the  to select the cooking time.
4. Press  to confirm the setting.

Example: to cook at 170 °C for 40 minutes.







1. Press  button once and the LED will display  and "200°C".
2. Continually to press  until 170 °C is displayed on the screen.
3. Turn the  to until 40:00 is displayed on the screen.
4. Press  to start the cooking.

To Preheat and Cook with Convection

Your oven can be programmed to combine preheating and convection cooking operations.

1. Press  button once and the LED will display  and "200°C".
2. Continually to press  to select cooking temperature.
3. Press  to start cooking. When the oven reaches the programmed temperature, one beep will sound every 5 seconds.
4. Open the door and place the food into the oven.
5. Turn the  to select cooking time.
6. Press  to start cooking.

Example: to preheat to 150 °C and then cook 30 minutes.

1. Press  button once and the LED will display  and "200°C".
2. Continually to press  until 150 °C is shown on the screen.
3. Press  to start cooking. When the oven reaches the programmed temperature, one beep will sound every 5 seconds.
4. Open the door and place the food into the oven.
5. Continue to turn the  until 30:00 is shown.
6. Press  to start cooking.



NOTE: When the cooking is finished, the oven will display **End** and beep every two minutes until the oven door is opened

or  button is pressed.

Operating Your Microwave Oven





Auto Defrost

The oven allows the defrosting food based on the weight you entered. The time and the defrosting power are adjusted automatically once the weight is programmed. The food weights range from 100g to 1800g.

1. Dial  anti-clockwise to select food code A-9.
2. Press  to select the weight of food.
3. Press  to start the cooking.

NOTE: When the cooking time is 1/2 through, the oven will pause and produce beep sound to This is normal. You can open the door and turn the food over. If you do not need to turn the food over, you can press  to continue the cooking.

Example: to defrost 600g of shrimp.

1. Dial  anti-clockwise to select food code A-9.
2. Press to  select the weight to 600g.
3. Press  to start the cooking.
4. After 1/2 time ,turn around the food,Press the  again.

Note: The max weight for defrost input is 1800g.

Defrost time and Power for different weight food chart.









Input Weight(g)	Cooking Time	Power	
		Stage 1	Stage 2
100	5:00	20%	20%
200	7:00	20%	20%
300	9:00	20%	20%
400	11:00	20%	20%
500	13:00	20%	20%
600	15:00	20%	20%
700	17:00	20%	20%
800	19:00	20%	20%
900	21:00	20%	20%
1000	23:00	20%	20%
1100	25:00	20%	20%
1200	27:00	20%	20%
1300	29:00	20%	20%
1400	31:00	20%	20%
1500	33:00	20%	20%
1600	15:00	20%	20%
1700	37:00	20%	20%
1800	39:00	20%	20%

- Note:
1. The cooking time for each stage is 1/2 of total cooking time.
 2. During the defrosting process, the oven will pause and produce beep sound to let you know while it is 1/2 through. This is normal. You can open the door and turn the food over. If you do not need to turn the food over, you can press  to continue the cooking.

Multi-stage Cooking

This microwave oven can be set up to 3 stage cooking.

Example : Cook with 60% microwave power for 10 minutes and 100% for 5 minutes.

1. To press  to select 60% microwave power, and it display 60%. 
2. Turn  clockwise to adjust the cooking time to 10 minutes, it display "10:00" 
3. Press  once , it display "100%" 
4. Turn  clockwise to adjust the cooking time to 5 minutes.
5. Press  to start the cooking.

Note

1. Deforst, Quick Start and Auto Cook cannot be set in multistage cooking program.
2. The oven will sound once after each stage and begin the next stage.

Quick Start

In the standby mode, Press the  button once, the oven will start to cook with 100% power for 30 sec.

Each additional press on the  button will increase the cooking time for 30 seconds. The longest time for this setting can be added up to 10 minutes .

Example: To cook for 2 minutes with 100% power .





Press  button 4 times and the LED displays  and the cooking time will increase to 2 minutes.









The oven starts cooking immediately at full microwave power.

Operating Your Microwave Oven

Microwave+Convection cooking

This oven has four pre-programmed settings that make it easy to cook with both convection heat and microwave automatically. The maximum cooking time is 95:00 minutes. You can press  during cooking to check cooking temperature. It is recommended that you should pre-heat the oven to the appropriate temperature before placing the food in oven.





1. In standby mode, press  to select cooking temperature, and the LED will show   and cooking temperature. 

No. of time to press  Button	Display	Microwave Cooking Time	Convection Cooking Time	Cycle(sec.)
Once	  200C	30%	70%	33
Twice	  170C	45%	55%	33
3 times	  140C	58%	42%	33
4 times	  110C	73%	27%	33

2. Turn the  to select the cooking time.

3. Press  to start cooking.





Example: set a micro+convection cooking program for 30 min at 140°C.

1. In standby mode, press  3 times to select 140°C cooking temperature, and the LED will show   and 140 C.
2. Turn the  dial until it shows 30:00.
3. Press  to start cooking.





NOTE: When the cooking is finished, the oven will display End and beep every two minutes until the oven door is opened or  button is pressed.

Auto Cook

This auto function has eight pre-set cooking program. You do not need to set either cooking times or power level. The table below shows the details of the programs.

1. In standby state, turn the  in anti-clockwise direction once and the LED displays "A-1".
2. Turn  to select the desire cooking program, i.e 1-8.
3. Press  to select weight / portion.
4. Press  to start the cooking.



Example: To cook one portion potato.



1. In standby state, turn the  in anti-clockwise and the LED displays “A-1”.
2. Turn  to select the Potato and the LED displays “A-1”.
3. Press  to select 1 portion.
4. Press  to start cooking.

Auto Cooking

Auto Cooking	Auto Manual	Weight	Display	Power
1	POTATO	1 portion / 230g	1	P-100
		2 portion / 460g	2	
		3 portion / 690g	3	
2	COFFEE	1 portion / 200ml	1	P-100
		2 portion / 400ml	2	
		3 portion / 600ml	3	
3	POPCORN	99g	99g	P-100
4	REHEAT	200g	200g	P-100
		300g	300g	
		400g	400g	
		500g	500g	
		600g	600g	
		700g	700g	
		800g	800g	
5	SPAGHETTI	100g	100g	P-80
		200g	200g	
		300g	300g	
6	PIZZA	150g	150g	Convection
		300g	300g	
		450g	450g	
7	CHICKEN	800g	800g	MICRO.+CONVECTION 200°C
		1000g	1000g	
		1200g	1200g	
		1400g	1400g	
8	CAKE	475g	475g	CONVECTION 140°C

Child Lock

Lock: In standby state, press  button over 3 seconds, a “beep” will be heard denoting entering the child lock state, and the lock indicator  will be illuminated.

Unlock: In locked state, press  button over 3 seconds, a “beep” will be heard denoting entering the lock is released, and the  locked indicator will disappear.

Warming Up and Heating

Times stated are approximate and can vary depending on the quality, size of the chopped pieces, storage temperature and moisture content of the foodstuff. It is advisable to set a shorter cooking time at first, and then if necessary continue the cooking process, until the food is cooked to your satisfaction.

Protection

OVERHEATING PROTECTION

When the system enters into super high temperature protection status, the digital display shows "E01" and continues to beep until troubleshooting, then press , the system comes back to normal standby mode.

LOW TEMPERATURE PROTECTION

When the system enters into low temperature protection status, the digital display shows "E02" and continues to beep until press , the system comes back to normal standby mode.

SENSOR MALFUNCTION PROTECTION

The system enters into protection mode when the system sensor is Short Circuited. The display shows "E03" and continues to beep until press , the system comes back to normal standby mode.

Operating Your Microwave Oven

Foodstuff	Quantity	Output Level	Time (Mins)	Remarks
Liquids				
Milk, 1 cup	150g	P100 (=100%)	0.5 - 1	Caution: Stir the liquid prior to and during heating/reheating, let liquid stand for at least 10 seconds after cooking and always take care when adding ingredients to hot liquids.
Water/Coffee /Milk 1 cup	150g	P100 (=100%)	1 - 2	Caution: Stir the liquid prior to and during heating/reheating, let liquid stand for at least 10 seconds after cooking and always take care when adding ingredients to hot liquids.
Water	500g	P100 (=100%)	3 - 5	Caution: Stir the liquid prior to and during heating/reheating, let liquid stand for at least 10 seconds after cooking and always take care when adding ingredients to hot liquids.
One-course meals/ Ready-to-serve meals	450g	P100 (=100%)	4 - 6	Cover.
Soups	250g	P100 (=100%)	1 - 2	Stir.
Stews	500g	P100 (=100%)	3 - 5	Stir between times.
Meat / Poultry				
Roast	250g	P100 (=100%)	2 - 3	
Rissoles/Meatballs	500g	P100 (=100%)	3 - 4	
1/2 Chicken	450g	P100 (=100%)	3 - 4	Lightly brush with oil.
Vegetables				
Portion x 1	150g	P100 (=100%)	1 - 2	Cover, stir.
Portions x 2	300g	P100 (=100%)	2 - 4	Cover, stir.
Side Dishes				
Noodles	150g	P100 (=100%)	1 - 2	Dampen slightly beforehand, cover, stir.
Rice	150g	P100 (=100%)	1 - 2	Dampen slightly beforehand, cover, stir.
Potatoes	500g	P100 (=100%)	3 - 4	Cover.
Baby Food	approx, 200g	P100 (=100%)	1 - 2	Stir well, check the temperature.
Meat				
Beef, Pork in one piece	500g	P 80 (= 80%)	11 - 14	Cover, turn halfway through cooking, leave to stand for 3-5 minutes.
Lightly smoked pork loin	500g	P 80 (= 80%)	12 - 15	
Meatloaf		P100 (=100%)	12 - 15	
Sausages	200g	P 80 (= 80%)	2 - 3	Pierce skin with fork.
Poultry				
Chicken	1000g	P100 (=100%)	20 - 25	Cover, turn once, leave to stand for 5 minutes.
Pieces of Chicken	250g	P80 (=80%)	4 - 5	

Fish				
Fresh fish	300g	P 80 (=80%)	(= 5 - 7	Cover, turn once, leave to stand for 3 minutes.
Fillet of fish	300g	P 80 (=80%)	(= 4 - 5	Cover, turn once, leave to stand for 3 minutes.
Frozen fish	400g	P100 (=100%)	8 - 10	Cover, leave to stand for 3 minutes.
Vegetables, fresh				
Cauliflower, fennel	broccoli, 150g	P100 (=100%)	8 - 10	Chop vegetables into small pieces, cook with liquid, (3-5 tablespoons), stir in between times leave to stand for 3-5 minutes, add spices, (salt before serving).
French beans	500g	P100 (=100%)	10 - 12	
Potatoes, potatoes	boiled 500g	P100 (=100%)	8 - 10	
Jacket potatoes	500g	P100 (=100%)	10 - 12	Prick the jacket for boiling potatoes.
Carrots	500g	P100 (=100%)	8 - 10	
Vegetables, frozen	deep			Take note of details on the packaging.
Leaf spinach	300g	P100 (=100%)	10 - 12	Cover, add some liquid, stir in between times, leave to stand for 3 - 5 minutes.
Peas	300g	P100 (=100%)	7 - 9	
Leeks	200g	P100 (=100%)	10 - 12	
Carrots	200g	P100 (=100%)	6 - 8	
Brussel sprouts	250g	P100 (=100%)	6 - 8	
Spinach	150g	P100 (=100%)+	3 - 4	
		P 30 (=30%)	(= 20 - 22	
Deserts				
Pudding/Flummery	500g	P100 (=100%)	6 - 8	

Cleaning your Microwave Oven

Attention

Your microwave oven should be cleaned regularly to prevent grease and food particles from building up on the inside surface. The accumulated grease /food particles may cause a fire hazard.

It's important to clean the interior of your microwave oven after each use.

To clean the oven interior, use a mild detergent solution, such as washing-up liquid, with warm water on a soft cloth.

It's suggested to place half a lemon in a bowl and add 300ml water inside the oven. Then heat it on 100% microwave power setting for 10 minutes. Wipe the oven clean with a soft , dry cloth.

IMPORTANT:

ALWAYS switch off oven and unplug from power supply.

ALWAYS use a branded cleaning spray, and for stubborn spots inside the oven, spray a small amount of cleaner onto a damp cloth.

DO NOT SPRAY DIRECTLY INSIDE THE OVEN.

Removable Parts.

- 1.The turntable may be cleaned at the sink. Be careful not to clip or scratch the edges as this may cause the turntable to break during use.
- 2.The turntable roller rest should be cleaned regularly.
- 3.Do not immerse the turntable glass in cold water.

Special Care

For best performance and safety, the inner door panel and the oven front frame should be free of food residue. To prevent damage to the operating parts inside the oven, water should not be allowed to seep into the ventilation openings.

Note

The oven may turn on the fan for around 3 minutes after the cooking has been finished. This is normal and it is to cool down the temperature inside the cavity.

Trouble Shooting and Maintenance

Normal Condition

Microwave oven interfering with TV reception.

Radio and TV reception maybe interfered with when microwave oven is operation. It is similar to the interference of small electrical appliances such as food mixers, vacuum cleaners and electric fans. This is normal .

Oven light dim.

In low power microwave cooking, oven light may become dim. This is normal.

Steam accumulating on door, hot air out of vents.

In cooking, steam may come out of food. Most will come out from vents but some may condense on cool places such as the oven door. This is normal.

Oven started accidentally with no food in.

Although starting the oven with no food in it should be avoided, it does no damage to the oven provided it is only operated empty for a very short time. It is advised that a glass or microwave safe container of water is always left in the oven to absorb any heat should the oven be turned on accidentally.

Trouble Shooting

Maintenance

Check for problems by using the chart below. If the microwave oven still does not work properly, contact the nearest authorised service centre.

PROBLEM	POSSIBLE CAUSE
Oven will not start	a. Plug not secure in power socket, or not switched on. b. Door is open. c. Wrong operation is set.
Arcing or sparking	a. Materials which should be avoided in microwave oven are used. b. The oven is operated when empty. c. Spilled food remains in the cavity.
Unevenly cooked food	a. Materials which should be avoided in microwave oven are used. b. Food is not defrosted completely. c. Power setting for cooking time is incorrect. d. Food is not turned or stirred.
Overcooked food	Power setting for cooking time is incorrect.
Undercooked food	a. Materials to be avoided in microwave oven are used. b. Food is not defrosted completely. c. Oven ventilation ports are restricted. d. Power setting for cooking time is incorrect.
Incomplete defrosting	a. Materials to be avoided in microwave oven are used. b. Power setting for cooking time is incorrect. c. Food is not turned or stirred.
Noise comes from turntable when oven is turned on	Food residue exists between the turntable roller rest and cavity bottom.
Oven light does not glow	a. The light bulb has burned out b. START has not been pressed.

QUESTIONS AND ANSWERS

Q: When the oven is plugged into a wall outlet for the first time, it does not work properly. What's wrong?

A: The microcomputer used in the oven control may temporarily become scrambled and fail to function as programmed. Unplug the oven from the wall outlet and then plug it back in. The microcomputer will then reset for proper functioning.

Q: Why is there noise coming from the oven when using a lower power level?

A: When cooking with power other than 100%, the oven automatically switches on and off to obtain the correct power output. The clicking noise can be heard when the oven switches on and off. This is normal

Q: Why is there steam coming out of the air exhaust vent?

A: Steam is produced during cooking. The microwave oven has been made to vent this steam.

Q: What is wrong when the oven light will not glow?

A: There may be several reasons why the oven light will not glow. The light bulb has burned out or START has not been pressed.

Q: Why do eggs sometimes burst?

A: The egg yolk may burst because of steam build-up inside the membrane. Pierce the membrane with a toothpick before cooking it. Never microwave eggs in the the shell as they may explode.

Q: How is boiling over avoided?

A: Use a larger utensil than usual for cooking. If you open the oven door or touch Pause / Cancel , the food will stop boiling.

IMPORTANT NOTES

1. Before first using this oven please read this instruction manual and keep it carefully.
 2. Do not attempt to repair the oven yourself, please consult an authorised expert.
 3. Check the oven and the cable regularly for damage. If there is any kind of damage, the oven should not be used.
- Warning:

- a. It is hazardous for anyone other than a trained person to carry out any service or repair operation which involves the removal of any cover which gives protection against exposure to microwave energy.
- b. Never allow children to use the oven without supervision unless adequate instructions have been given so that the children are able to use the oven in a safe way and understand the hazards of improper use.
- c. If the supply cord is damaged, it must be replaced by the manufacturer or its service agent or a similarly qualified person in order to avoid a hazard.

NOTE

- Do not attempt to operate this oven with the door open since open-door operation can result in harmful exposure to microwave energy. It is important not to try and override or tamper with the safety interlocks.
- Carefully clean door seals and sealing surfaces.
- Do not operate the oven if it is damaged. It is particularly important that the oven door closes properly and that there is no damage to the, (1) door (i.e. door is not bent or dented), (2) hinges and latches (broken or loosened), (3) door seals and sealing surfaces.
- Utensils should be checked to ensure that they are suitable for use in microwave ovens.
- If the door or door seals are damaged the oven must not be operated until it has been repaired by a trained person.
- Warning: Children less than 8 years of age shall be kept away unless continuously supervised.
- The temperature of accessible surfaces may be high when the appliance is operating. The surfaces are liable to get hot during use. Keep cord away from heated surface, and do not cover any events on the oven.
- Children should be supervised to ensure that they do not play with the appliance.
- The appliances are not intended to be operated by means of an external timer or separate remote-control system.

BULB REPLACEMENT

If the interior light bulb fails, it can be easily replaced by a qualified service engineer. Do not attempt to remove the outercasing, as this will expose live components. Please consult a qualified service engineer.

Technical Specifications

Model	D90D25ESLRIII-ZWB
Power Source:	230-240V-50Hz
Microwave Power Consumption:	1400 Watt
Microwave Maximum Output:	900 Watt
Convection Power Input	1950 Watt
Grill power input	1000 Watt
Operation Frequency:	2450 MHz
Oven Capacity:	25 Litres
Turntable Diameter:	Ø 270 mm
External Dimensions (Hx W x D):	281x483x430 mm
Net Weight:	Approx. 16Kg

We apologize for any inconvenience caused by any minor inconsistencies in these instructions, which may occur as a result of product improvements and development.

For future help, please call the customer helpline: 0345 640 3030.

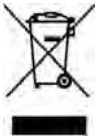

The symbol on the product or its packaging indicates that this product may not be treated as household waste. Instead it should be handed over to the applicable collection point for the recycling of electrical and electronic equipment. By ensuring this product is disposed of correctly, you will help prevent potential negative consequences for the environment and human health, which could otherwise be caused by inappropriate waste handling of this product. For more detailed information about recycling this product, please contact your local council office, your household waste disposal service or the shop where the product was purchased.



PRODUCT GUARANTEE

This product is guaranteed against manufacturing defects for a period of



Year

This product is guaranteed for twelve months from the date of original purchase.

Any defect that arises due to faulty materials or workmanship will either be replaced, refunded or repaired free of charge where possible during this period by the dealer from whom you purchased the unit.

The guarantee is subject to the following provisions:

- The guarantee does not cover accidental damage, misuse, cabinet parts, knobs or consumable items.
- The product must be correctly installed and operated in accordance with the instructions contained in this manual.
- It must be used solely for domestic purpose.
- The guarantee will be rendered invalid if the product is re-sold or has been damaged by inexpert repair.
- Specifications are subject to change without notice.
- The manufacturer disclaims any liability for the incidental or consequential damages.
- The guarantee is in addition to, and does not diminish your statutory or legal rights.

Guarantor: Argos Ltd.
489 - 499 Avebury Boulevard
Central Milton Keynes
MK9 2NW