



**MCGREGOR 18V CORDLESS  
PRESSURE CLEANER**

4498632(Model: MCLPW18)

Vi: 11/24



**CAUTION** Read the instructions before using the machine

These instructions contain important information that will help you get the best from your pressure cleaner, ensuring it is assembled correctly and safely. If you need help or have damaged or missing parts, call the Customer Helpline on **0345 605 2062**

**AFTER SALES SUPPORT**  
**0345 605 2062**  
SAN NO.: 0321802016ZE

# Contents

Safety information .....	2
Parts list .....	16
Assembly .....	17
Preparation.....	18
Operation .....	21
Maintenance .....	23
Technical data .....	25
Trouble shooting .....	27
Guarantee .....	28

Produced in China for Argos Limited, London, EC1N 2HT, UK.

Argos (N.I.) Ltd, Forestside Shopping Centre, Upper Galwally, Belfast, BT8 6FX, UK.

<https://bit.ly/Coreservice-McGregor>



# Safety Information

Important - Please read these instructions fully before operating or maintaining

## Explanations and symbols, cautions and warnings

On the product, the rating label and within these instructions you will find among others the following symbols and abbreviations. Familiarise yourself with them to reduce hazards like personal injuries and damage to property.



Read the instruction manual.



Wear hearing protection.



Wear eye protection.



Wear respiratory protection.



Wear protective gloves.



Wear protective, slip-resistant footwear.



Always ensure that other people and pets remain at a safe distance from the product when it is in operation. In general, children must not come near the area where the product is.



Do not expose the product to rain or wet conditions.



This product is not suitable for connection to the potable water mains.



# Safety Information

Important - Please read these instructions fully before starting assembly

## Explanations and symbols, cautions and warnings



Do not direct the water jet onto people, animals, electrical equipment or onto the product itself.

T3.15A



With fuse 3.15 A



Do not dispose of battery packs in rivers or immerse in water.



Do not dispose of battery packs in fire. They will explode or leak and cause injury.



Do not expose battery packs to heat in excess of 45°C.



Recycle electrical waste products in an environmentally safe way where facilities exist.



Charger is of protection class II. That means it is equipped with enhanced or double insulation.



The product complies with the applicable European directives and an evaluation method of conformity for these directives was done.



The product complies with the applicable UK Conformity Assessed directives and an evaluation method of conformity for these directives was done.



# Safety Information

Important - Please read these instructions fully before starting assembly

## Explanations and symbols, cautions and warnings



WEEE symbol. Waste electrical products should not be disposed of with household waste. Please recycle where facilities exist. Check with your Local Authority or local store for recycling advice.



Crossed out dust bin. Batteries and battery packs should not be disposed of with household waste. Please recycle where facilities exist. Check with your Local Authority or local store for recycling advice.



Batteries contain Lithium-ion. Do not dispose of batteries in household waste.



# Safety Information

Introduction

## Safety warnings

This appliance can be used by persons with reduced physical, sensory or mental capabilities or lack of experience and knowledge if they have been given supervision or instruction concerning use of the appliance in a safe way and understand the hazards involved. Children shall not play with the appliance.



**WARNING:** This product has been designed for use with the cleaning agent supplied or recommended by the manufacturer. The use of other cleaning agents or chemicals may adversely affect the safety of the machine.



**WARNING:** During use of pressure cleaners, aerosols may be formed. Inhalation of aerosols can be hazardous to health.



**WARNING:** Pressure jets can be dangerous if subject to misuse. Never direct the jet at persons, live electrical equipment or the product itself.

- The liquid must not be directed towards equipment containing electrical components, such as the interior of ovens.



**WARNING:** Do not use the machine within range of persons unless they wear protective clothing.



**WARNING:** Do not direct the jet against yourself or others in order to clean clothes or foot-wear.



# Safety Information

Important - Please read these instructions fully before starting assembly

## Safety warnings



**WARNING:** Risk of explosion - Do not spray flammable liquids.



**WARNING:** Pressure cleaners shall not be used by children or untrained personnel.



**WARNING:** Pressure hoses, fittings and couplings are important for the safety of the product. Use only hoses, fittings and couplings recommended by the manufacturer.



**WARNING:** To ensure machine safety, use only original spare parts from the manufacturer or approved by the manufacturer.



**WARNING:** Water that has flowed through backflow preventers is considered to be non-potable. **WARNING:** Remove the battery from the product during cleaning or maintenance and when replacing parts or converting the machine to another function. **WARNING:** Do not use the machine if a supply cord or important parts of the machine are damaged, e.g. safety devices, pressure hoses, trigger gun.



**WARNING:** Always switch off the mains disconnecting switch when leaving the machine unattended.



**WARNING:** Remove the battery pack from the machine during cleaning or maintenance and when replacing parts or converting the machine to another function.



# Safety Information

Important - Please read these instructions fully before starting assembly

## Safety warnings

- Never use the product with inflammable or toxic liquids, or liquids with characteristics incompatible with its proper operation.
- Never use the product outdoors in the rain.
- Never lock the gun trigger in the operating position.
- Check that the product is fitted with its rating label; contact your dealer if it is missing. Products without rating label must not be used, since they cannot be identified and are potentially hazardous.
- Never tamper with or adjust the setting of the safety valve or the safety devices.
- Never change the original diameter of the adjustable nozzle.
- The appliance shall not be left unattended while it is connected to the supply mains.
- Do not allow vehicles to drive over the pressure hose.
- Do not move the product by pulling on the pressure hose.
- When directed towards tyres, tyre valves or other pressurised components, the pressure jet is potentially dangerous. Do not apply a jet stream and always keep the nozzle at a distance of at least 30 cm during cleaning.
- Protect all electrical conductors against the water jet.
- Pressure may cause parts to rebound: wear all the protective clothing and equipment needed to ensure the operator's safety.
- Wear appropriate Personnel Protection Equipment (PPE) while operation e.g. safety boots, safety



# Safety Information

Important - Please read these instructions fully before starting assembly

## Safety warnings

gloves, safety helmets with visors, hearing protection etc.

- Be aware of kick-back: grip the gun firmly when squeezing the trigger.
- Comply with the regulations of the local water supply authority. Under EN 12729 (BA) the product can be connected directly to the mains drinking water supply only if the supply hose is fitted with a backflow preventer device with drainage facility.
- Discharge residual pressure before disconnecting the hose from the product.
- Check before each use, and at regular intervals, that all metal fasteners are tight and the product's components are in good condition; inspect for broken or worn parts.
- The appliance is not to be used if it has been dropped, if there are visible signs of damage or if it is leaking.
- Keep the appliance out of reach of children when it is energized or cooling down.



**WARNING:** Use only detergents compatible with the pressure hose cladding materials or other cladding materials.

**CAUTION!** Use only approved replacement batteries; other batteries may cause injury or damage to the product.

Use with approved battery charger.

- Recharge only with the charger specified by the



# Safety Information

Important - Please read these instructions fully before starting assembly

## Safety Warnings for Battery pack and Charger Battery Safety Instructions

manufacturer. A charger that is suitable for one type of battery pack may create a risk of fire when used with another battery pack. Incorrect use may result in electric shock, overheating or leakage of corrosive liquid from the battery.

- Use product only with specifically designated battery packs. Use of any other battery packs may create a risk of injury and fire.
- When battery pack is not in use, keep it away from other metal objects like paper clips, coins, keys, nails, screws, or other small metal objects that can make a connection from one terminal to another. Shorting the battery terminals together may cause sparks, burns, or a fire.
- Under abusive conditions, liquid may be ejected from the battery; avoid contact. If contact accidentally occurs, flush with water. If liquid contacts eyes, additionally see medical help. Liquid ejected from the battery may cause irritation or burns.
- Be aware of possible hazards when not using your battery tool or when changing accessories. To reduce risk, remove the safety key and battery pack from the machine while not in operation. This will reduce the risk of electric shock, fire or serious personal injury.
- Do not place appliances or their batteries near fire or heat. Continuous intense sunlight, fire or other heat sources may cause an increased danger of explosion.



# Safety Information

Important - Please read these instructions fully before starting assembly

## Safety Warnings for Battery pack and Charger Battery Safety Instructions

- Do not crush, drop or damage the battery pack. Do not use a battery pack or charger that has been dropped or received a sharp blow. A damaged battery is subject to explosion. Properly dispose of a dropped or damaged battery immediately.
- Batteries can explode in the presence of a source of ignition, such as a pilot light. To reduce the risk of serious personal injury, never use any cordless product in the presence of an open flame. An exploded battery can propel debris and chemicals. If exposed, flush with water immediately.
- Do not charge battery in a damp or wet location. Following this rule will reduce the risk of electric shock.
- Longer life and better performance can be obtained if the battery pack is charged when the air temperature is between 18°C and 24°C. Do not charge the battery pack in air temperature below 4°C or above 40°C. This is important as it can prevent serious damage to the battery pack.
- Do not disassemble the battery and avoid mechanical damage to the battery. Risk of short circuit and fumes may be emitted. Ensure fresh air and seek medical assistance in the event of discomfort.
- Always remove battery pack from your tool when you are assembling parts, making adjustments, cleaning, or when not in use. Removing battery



# Safety Information

Important - Please read these instructions fully before starting assembly

## Safety Warnings for Battery pack and Charger Battery Safety Instructions

pack will prevent accidental starting that could cause serious personal injury.

- Always remove battery pack before storing the device. When battery becomes fully charged, unplug the charger from the power supply and remove the battery pack from the charger.
- Keep battery pack dry, clean, and free from oil and grease. Always use a dry cloth when cleaning. Never use brake fluids, gasoline, petroleum-based products, or any solvents to clean battery pack.
- Keep the battery pack out of the reach of children.
- Rechargeable batteries are to be removed from the appliance before being charged.
- Different type of batteries or new and used batteries are not to be mixed.
- Batteries are to be inserted with the correct polarity.
- The supply terminals are not to be short-circuited.

**CAUTION!** Use only approved replacement batteries; other batteries may cause injury or damage to the product.

Use with approved Lithium-Ion battery.

- The plug of the charger must match the outlet. Never modify the plug in any way. Unmodified plugs and matching outlets will reduce the risk of electric shock.
- Ensure the battery pack is charged indoors only, in a dry, cool and well-ventilated environment.



# Safety Information

Important - Please read these instructions fully before starting assembly

## Safety Warnings for Battery pack and Charger Battery Safety Instructions



- Do not subject the battery to strong sunlight over long periods and do not leave it near a heat source. Heat damages the battery and there is a risk of explosion.
- Allow a hot battery to cool before charging.
- Do not use non-rechargeable batteries!
- Do not attempt to charge battery packs other than those supplied. The charger and battery pack supplied with it are specifically designed to work together.
- Before each use, check the charger, cable and plug. Do not use a defective charger and do not disassemble the charger. Incorrect reassembly may result in the risk of fire, electric shock or electrocution.
- Protect the charger against moisture and wet conditions. There is a danger of electric shock.
- Operate the charger only with the appropriate original batteries. Charging other batteries may result in injuries and risk of fire.
- Avoid mechanical damage to the charger. This can result in internal short circuits.
- Do not operate the charger on easily inflammable surfaces (e.g. paper, textiles, etc.). The heating of the battery charger during the charging process could pose a fire hazard.
- Do not abuse the cord of the charger. Never use the cord for carrying, pulling or unplugging the charger.



# Safety Information

Additional safety instructions for grass trimmers

## **Safety Warnings for Battery pack and Charger Battery Safety Instructions**

- Keep the cord away from heat, oil, sharp edges or moving parts. Damaged or entangled cords increase the risk of electric shock.
- Do not operate the charger with a damaged cord or plug, which could cause shorting and electric shock. If damaged, immediately discontinue use. Replace the charger with the identical unit as listed in the Product Specifications in this manual. If the power cord for this equipment is damaged, it must be replaced by the manufacturer, a customer service agent of the same or qualified person in order to prevent hazards.
- The battery of the appliance is not fully charged at the time of delivery. It therefore needs to be fully recharged before you use it for the first time. For the first recharge cycle, charge the battery pack fully. Slot the battery into the base and plug the battery charger into an outlet.
- Do not use a charger that has been dropped or received a sharp blow.
- The voltage indicated on the charger rating plate must correspond to the voltage of the power source.
- Never touch the mains plug with wet hands.
- It is good practice to unplug the charger and remove the lithium- ion battery pack when not in use.

The following information applies to professional users only but is good practice for all users:



# Safety Information

Important - Please read these instructions fully before starting assembly

## Safety Warnings for Battery pack and Charger Battery Safety Instructions

To reduce the impact of noise and vibration emission, limit the time of operation, use low-vibration and low-noise operating modes as well as wear personal protective equipment.

Take the following points into account to minimise the vibration and noise exposure risks:

- Only use the product as intended by its design and these instructions.
- Ensure that the product is in good condition and well maintained.
- Use correct accessories for the product and ensure they are in good condition.
- Keep tight grip on the handles/grip surface.
- Maintain this product in accordance with these instructions and keep it well lubricated (where appropriate).
- Plan your work schedule to spread any high vibration tool use across a longer period of time.
- Prolonged use of the product exposes the user to vibrations that can cause a range of conditions collectively known as hand-arm vibration syndrome (HAVS) e.g. fingers going white; as well as specific diseases such as carpal tunnel syndrome. To reduce this risk when using the product, always wear protective gloves and keep your hands warm.

Familiarise yourself with the use of this product by means of this instruction manual. Memorise the safety



# Safety Information

Important - Please read these instructions fully before starting assembly

## Vibration and noise reduction

directions and follow them to the letter. This will help to prevent risks and hazards.

- Always be alert when using this product, so that you can recognise and handle risks early. Fast intervention can prevent serious injury and damage to property.
- Switch off and disconnect from the power supply if there are malfunctions. Have the machine checked by a qualified professional and repaired, if necessary, before you operate it again.

Even if you are operating this product in accordance with all the safety requirements, potential risks of injury and damage remain. The following dangers can arise in connection with the structure and design of this product:

- Health defects resulting from vibration emission if the product is being used over long periods of time or not adequately managed and properly maintained
- Injuries and damage to property due to broken attachments or the sudden impact of hidden objects during use.
- Danger of injury and property damage caused by flying objects.



**WARNING!** This product produces an electromagnetic field during operation! This field may under some circumstances interfere with active or passive medical implants! To reduce the risk of serious or fatal injury, we recommend persons with medical implants to consult their doctor and the medical implant manufacturer before operating this product!

# Part List

## Parts Description

1. Pressure cleaner
2. Battery pack
3. Charger
4. 5 in 1 lance
5. Foam bottle

6. Hose
7. Nozzle pin
8. Manual

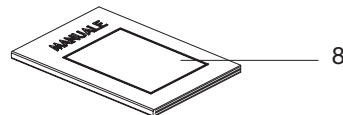
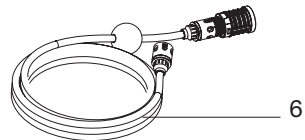
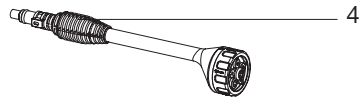
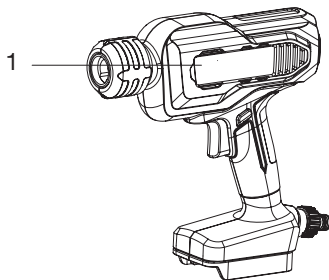
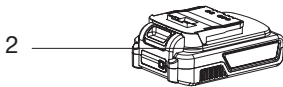
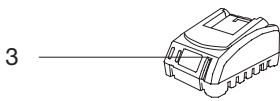

# Assembly

## Step 1 5 in 1 lance assembly

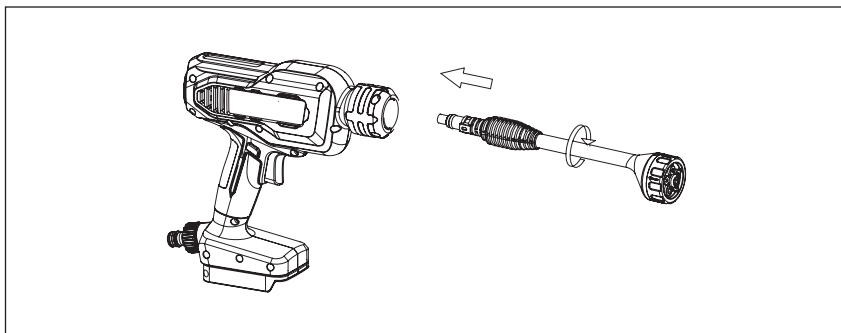

Fit the 5 in 1 lance (4) into the pressure cleaner firmly by aligning the two tabs on the lance with the grooves in the pressure cleaner, and rotate it as shown in the picture until the two parts are completely locked.

# Preparation

## Step 1 Checking battery capacity



### WARNING!

The charger and battery pack are specifically designed to work together so do not attempt to use any other devices. Never insert or allow metallic objects into your charger or battery pack connections; an electrical failure and hazard will occur.

The battery needs to be charged before first use and whenever it fails to produce sufficient power on jobs that were easily done before.

- Press the battery capacity level button to check the charging level of the battery pack. The battery capacity will be shown on the battery charging level indicators.

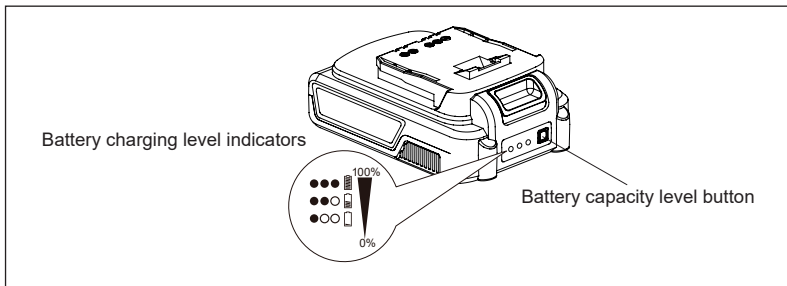

Battery charging level indicators.	Battery capacity
●○○□	≤ 35% and need to be charged
●●○□	35-65%
●●●■	≥ 65%

# Preparation

## Step 2 Charging the battery

- Connect the charger to a power supply. The red LED will illuminate.
- Slide the battery pack into the charger fully, the red indicator is on and the green indicator is flashing means the battery is in charging.
- Complete charging, the red LED is off and the green LED is on.
- Once the battery is fully charged, disconnect the charger from the mains and remove the battery pack from the charger.

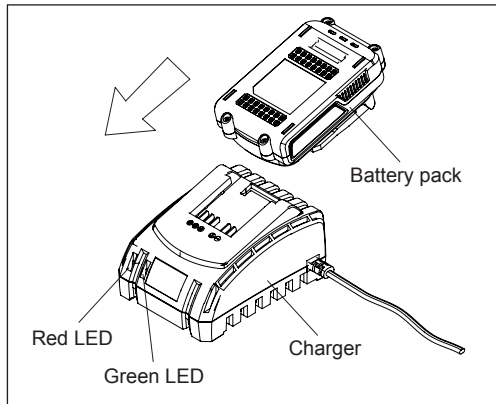

LED Light on Charger (Red & Green)	Charger Status
■ □	Stand by
■ -  □	In charging
□ ■	Battery pack is fully charged
-  □ (2 times/second)	Battery pack faulty
-  □ (1 time/second)	Battery pack overheat



**Attention!** It can not be charged immediately after using the machine. The battery pack should be cooled for a period of time.



**Note:** Charging time varies from different battery pack capacities.

# Preparation

## Step 3 Attach the hose to the pressure cleaner

To connect the equipped hose pipe with the pressure cleaner, pull down the collar of the quick connector and fit it onto the connector. Release the collar to lock the hose in place.

NOTE: Make sure the hose is connected securely. Gently pull the hose connection to confirm it won't come off.

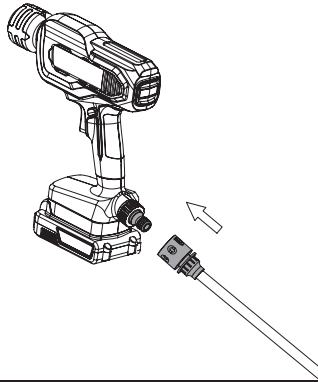

## Step 4 Battery Assembly

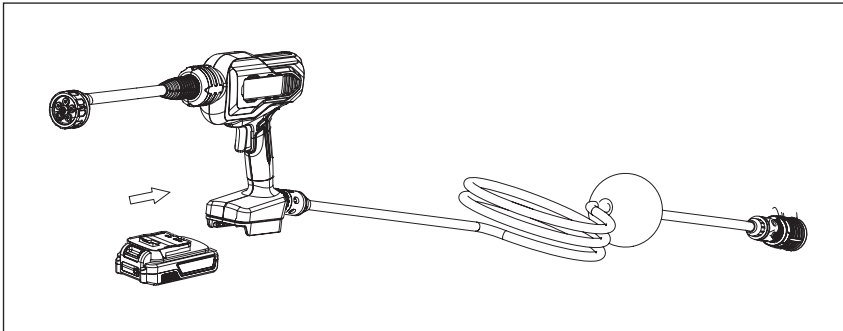

Push the battery pack into the handle until the latch into place

# Operation

## Step 1 On/Off Operation

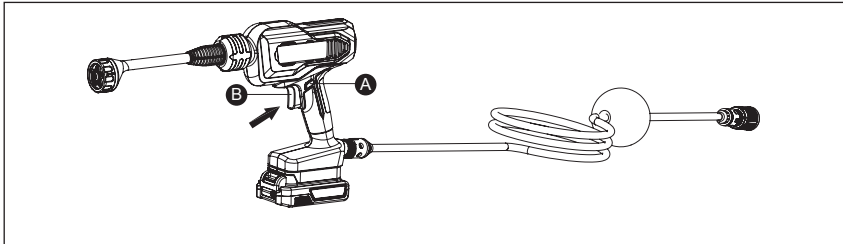

1. If connected with tap water, turn the water supply tap on completely. If hose pipe connects to water tank, please make sure the hose end is immersed into the water completely.
2. Push the safety lock (A) on the spray gun handle, with the safety lock (A) pressed, engage the trigger (B) for a few seconds until the water flow is steady, and then safety lock (A) can be released.
3. Release the trigger (B) the power cleaner will turn off.

## Step 2 Adjust 5 in 1 Lance

Whilst holding the lance, rotate the nozzle to your selected position, making sure that the nozzle is aligned with the lance arrow.



**WARNING:** Do not rotate the nozzle when operating the pressure cleaner.

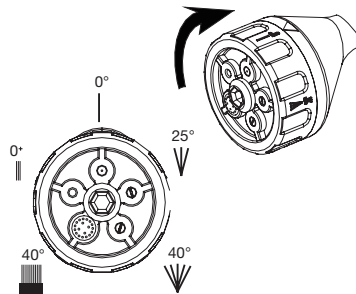

# Operation

## Step 3 Foam bottle



**WARNING:** In case of skin contact with detergents: rinse with an abundance of clean water.  
Always turn off the machine when changing the detergent bottle.

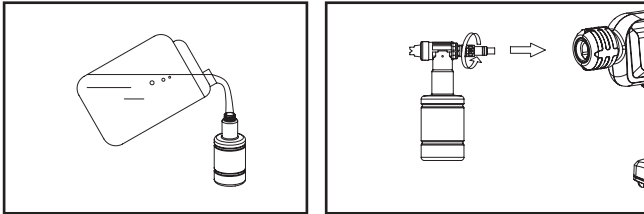

1. Unscrew the bottle cap of the detergent bottle. Pour the detergent into the detergent bottle. Screw on the bottle cap tight.
2. Fit the detergent bottle to the trigger gun.
3. Turn on the pressure washer. Pull trigger to operate unit. The liquid detergent will automatically mix with water and be discharged through the nozzle. Apply detergent to a DRY work surface from bottom to top.

# Maintenance

## Overview of cleaning

- After every use, wipe the machine with a slightly damp cloth. Do not clean the machine by using a pressure cleaner jet.
- Clean the high-pressure jet nozzle.

The pressure cleaner is equipped with a water filter in inlet adapter to protect the pump. If the filter is not kept clean, the water flow to the machine will be restricted and the pump may be damaged.

To clean water filter, remove inlet adapter and get the filter out.

- Rinse filter until it is free of debris and blockage.
- Replace the filter and inlet adapter.

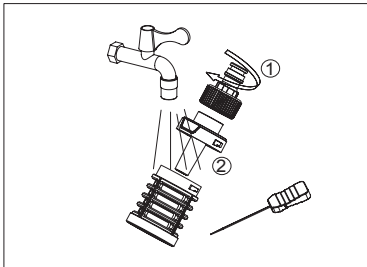
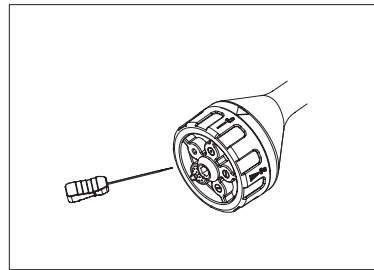
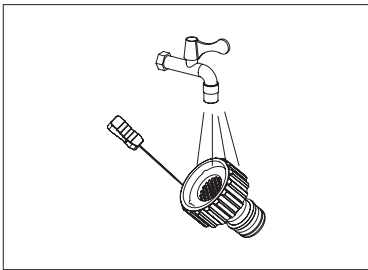

Over a period of time, limescale may build up on your lance outlet, use the nozzle cleaning pin to clean this away.



**WARNING!** Please keep the nozzle pin away from children.

# Maintenance



**WARNING - If Salty water has been used, make sure the cleaner has been fully flushed out for 5 minutes using clean warm water.**

## Storing

Store the machine where it is dry and well ventilated.

When placing the machine out of service for an extended period of time, remove the cleaning agent and drain all the water left in the hoses.

## Transport

If shipping, use the original packaging wherever possible.

## Disposal

### Disposing of the machine

Machines which are labelled with the this symbol must not be disposed in household rubbish. You must dispose such old electrical and electronic appliances separately.



Please check with your local authority about the possibilities for correct disposal. You will thus help to avoid that damaging into the environment.

## Disposing of the packaging

The packaging consists of cardboard and correspondingly marked sheets that can be recycled. Make these materials available for recycling.

# Technical Data

## Technical Data Table

Model No.	MCLPW18
Voltage	18V 
Rated pressure	2.2 MPa
Max pressure	2.4 MPa
Rated flow rate	2 l/min
Max flow rate	6.1 l/min
Net weight	1.8kg
Hose length	5m
A weighted sound pressure level	$L_{pA}=76\text{dB(A)}$ $K=3\text{dB(A)}$
Measured sound power level	$L_{wA}=87.96\text{dB(A)}$ $K=0.49\text{dB(A)}$
Guaranteed sound power level	91dB(A)
Vibration	$<2.5\text{m/s}^2$ $K=1.5\text{m/s}^2$
<b>Battery pack</b>	
Model	B0P-SP07-20ZM
Voltage	18V 
Battery type	Lithium-Ion
Battery capacity	2.0Ah
Fully charging time	1 Hour
<b>Charger</b>	
Model	B0Q-SP06-20ZB
Input	220-240V~, 50/60Hz 65W
Output	20V  2.4A
Insulation protection class	II

# Technical Data

## Disposal and Recycling

Recycle unwanted materials instead of disposing of them as waste. All tools, hoses and packaging should be sorted, taken to the local recycling centre and disposed of in an environmentally safe way.

Recycle rather than dispose of unwanted material in landfill whenever possible. The machine must be delivered in rigid packaging to avoid damage during transportation. The packaging and the machine itself are manufactured from recyclable materials and should be disposed of accordingly.

Only dispose of electrical/electronic/battery items in separate collection schemes, which cater for the recovery and recycling of materials contained within. Your cooperation is vital to ensure the success of these schemes and for the protection of the environment.

Recycle packaging where facilities exist.

This symbol is known as the Crossed out Wheelie Bin Symbol. When this symbol is marked on a product or battery, it means that it should not be disposed of with your general household waste. Some chemicals contained within electrical/electronic products or batteries can be harmful to health.

# Troubleshooting

## Troubleshooting



### Warning

Only perform the steps described within these instructions!

All further inspection, maintenance and repair work must be performed by an authorised service center or a similarly qualified specialist if you cannot solve the problem yourself!

Always turn off the machine and remove the plug before making any adjustment.

Problem	Possible Cause	Solution
Motor fails to start when power switch is turned on.	Battery is not secure.	To secure the battery pack, make sure the latches on the top of the battery pack snap into place.
	Battery is not charged.	Charge the battery pack according to the instructions included with your model.
Unit will not start.	Defective power switch.	If within warranty period return product to retailer of purchase.
Unit will not blow.	Blocked tube.	Clear the blockage.

## Getting Help

### Customer Helpline 0345 605 2062

Our dedicated UK based customer service centre is open 7 days a week to assist you with assembly, parts queries and technical support. We are open during office hours. Our experts are here to get you back enjoying your garden in no time.

Calling our service does not affect your statutory rights.  
UK/N.I. 0345 605 2062

# Guarantee

## Dear Customer,

In the unlikely event that your device develops a fault, please contact our customer service department on the following telephone number shown below (0345 605 2062).

1. These guarantee terms cover additional guarantee rights and do not affect your statutory warranty rights.  
Claims must be accompanied by Proof of Purchase. This must be in the form of a sales receipt or bank statement and must show that the product has been purchased within 2 years prior to the claim, from the retailer that it was originally sold to.
2. Our guarantee covers problems caused by material or manufacturing defects, and will result in the repair of these defects or replacement of the device with a like for like or similar article. Please note that our devices have not been designed for use in commercial, trade or industrial applications. Consequently, the guarantee is invalidated if the equipment is used in commercial, trade or industrial applications or for other equivalent activities.
3. The guarantee is valid for a period of 2 year starting from the purchase date of the device. Guarantee claims should be submitted before the end of the guarantee period within two weeks of the defect being noticed. No guarantee claims will be accepted after the end of the guarantee period. The original guarantee period remains applicable to the device even if repairs are carried out or parts are replaced. In such cases, the work performed or parts fitted will not result in an extension of the guarantee period, and no new guarantee will become active for the work performed or parts fitted. This also applies when an on-site Service is used.
4. Please keep your sales receipt in a safe place. If the defect is covered by our guarantee your device will either be repaired under the terms of guarantee or we will send you a replacement device. This device may be re-conditioned or Like for like replacement.