

28L Rotisserie Mini Oven with Hob

morphyrichards®

Installation & User Instructions –
Please keep for future reference

KH-J28RCL-E1Dkh



www.morphyrichards.com

Contents

Safety Information.....	3
Parts	6
Oven functions.....	7
Before first use.....	7
Fitting the crumb tray and racks.....	8
Using the racks and other cooking vessels.....	9
Assembling and fitting the rotisserie spit.....	10
Basic oven operation.....	11
Hob use.....	13
Rotisserie operation.....	15
Cleaning your oven.....	16
Replacing the bulb.....	17
Technical Specification.....	18
Recycling electrical products.....	18
Plug / Wiring advice	19
Guarantee.....	20

Safety information

Important – Please read these instructions fully before installation

Electrical safety

- You should only plug the appliance into a 220V-240V AC, 50Hz supply. Connecting it to other power sources may damage the appliance and will invalidate the guarantee.
- Switch off and unplug when not in use and before cleaning the appliance.
- Keep the appliance and its cord out of reach of children less than 8 years.
- Do not allow children to use the appliance without supervision.
- This appliance can be used by children aged from 8 years and above and persons with reduced physical, sensory or mental capabilities or lack of experience and knowledge if they have been given supervision or instruction concerning use of the appliance in a safe way and understand the hazards involved. Children shall not play with the appliance. Cleaning and user maintenance shall not be made by children unless they are older than 8 and supervised.
- Keep cable and plug and appliance dry and away from areas where it is likely to get splashed. Never immerse in water. Never clean with a steam cleaner.
- Do not pull on the cable to disconnect from mains supply.
- Do not operate the appliance if damaged or after it malfunctions. In the event the supply cord is damaged, in order to avoid a hazard it must only be replaced by a qualified service engineer, with a suitably approved part.
- This appliance must be positioned so that the plug is accessible and the plug socket is within easy reach of the power cord.
- This appliance must be plugged into an earthed socket outlet.

Warning!

- This appliance is intended exclusively for use in domestic households. It is not suitable for commercial use.
-  The surfaces of the oven and the containers inside will become hot during and immediately after use; wear oven gloves when handling. Note the elements are subject to residual heat after use. Do not touch.
- **Do not leave unattended during use.** Bread and other foodstuffs can catch fire if overdone.
- Do not use the oven on, near or under flammable or heat sensitive items. Place the back of the oven against the wall and leave a clear gap of at least 12cm on all sides and 50 cm above the oven to allow adequate ventilation
- Do not cover and allow the oven to cool fully before storing.
- Do not operate the oven using a timer or separate remote control.
- Do not use without the crumb tray fitted. Ensure crumb tray is fitted **below** the lower heating elements. If incorrectly positioned in the oven it could lead to abnormally high temperatures.
- Do not place tinned or bottled food in this oven.
- If smoke is emitted, switch off the appliance and keep the door closed in order to stifle any flames. Smother with a damp cloth or fire blanket.
- Do not permit food or cooking vessels to touch the four heating elements, the sides, roof or base of the oven cavity.
- Only use for intended purpose - cooking or grilling food. This appliance can cause personal injury if misused.

Food safety

- Thoroughly defrost frozen meat, poultry, fish and seafood in the refrigerator before cooking unless cooking from frozen advice is provided by the food packaging.
- Keep raw meat and poultry separate from cooked foods.
- Always wash hands after handling raw meat and poultry, before handling any ready to eat foods.
- Wipe and disinfect surfaces that have been in contact with raw meat and poultry.
- Use separate utensils for handling raw meat/poultry and cooked food or wash them thoroughly between use.
- To check whether meat, particularly poultry, is cooked, pierce the flesh with a skewer or fork; the juices should run clear. Ensure the product is piping hot throughout.
- Fish is cooked when it appears opaque and can be flaked easily.

Parts

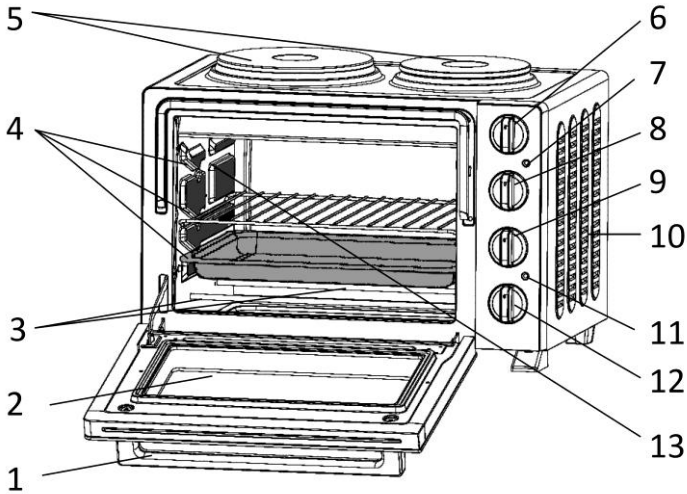

- | | | |
|---------------------------|-----------------------------|---------------------------------|
| 1. Door handle | 6. Temperature control knob | 10. Air vents |
| 2. Glass door | 7. Hotplate indicator | 11. Oven indicator |
| 3. Lower heating elements | 8. Left hotplate knob | 12. Function knob |
| 4. Rack supports | 9. Right hotplate knob | 13. Bracket for rotisserie spit |
| 5. Hotplates | | |

Grill rack

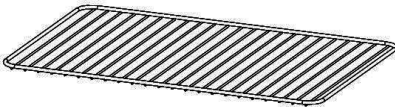

Baking tray

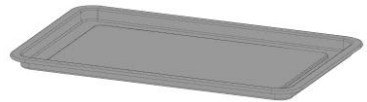

Rack / Tray handle

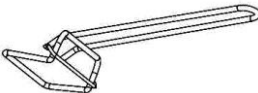

Crumb tray







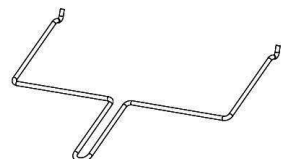

Rotisserie spit



Rotisserie handle



Oven functions

Symbol		Suggested use
	Hotplates and heating elements off	During storage and for timer use.
	Upper heating elements with fan assist	Toasting and grilling
	Upper and lower heating elements	Baking and roasting
	Upper and lower heating elements with fan assist	Convection cooking using the upper and lower heaters.
	Rotisserie with upper heating elements	Spit roasting meat and poultry
	Rotisserie with upper and lower heating elements with fan assist	Faster spit roasting of meat and poultry

Before first use

1. Dispose of all packaging safely.
2. Become familiar with -
 - The parts of the oven – see page 6
 - Where to fit the crumb tray - see fig 1
 - Where to fit the baking tray and rack – see fig 2
 - How to fit the handle to the baking tray and grill rack - see figs. 3 & 4.
 - How to assemble and fit the rotisserie spit and practice how to lift out the spit with the rotisserie handle - see figs. 5 – 9.
 - How to open and close the door – see figs. 10 -12
3. Some smoke may be emitted when the oven is first used. To eliminate any manufacturing residues, open the room window and operate the empty oven at maximum temperature for 10 minutes.
4. Clean oven and all detachable parts in accordance with the cleaning section of these instructions.

Fitting the crumb tray and racks

- Slide the crumb tray **underneath** the lower heating elements so that it lays flush with the base of the oven (fig. 1)

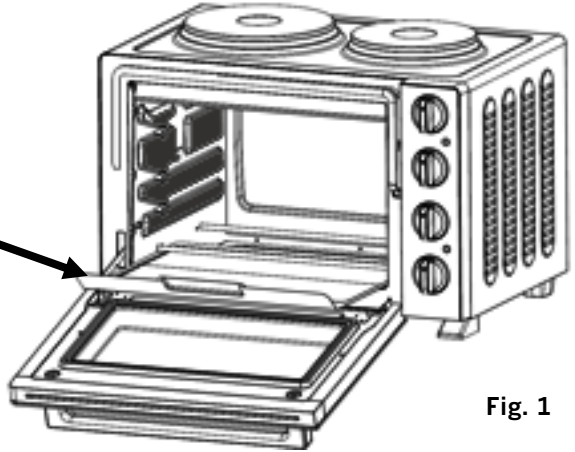

Fig. 1

- Slide the grill rack and / or baking tray onto the rack supports (fig. 2)

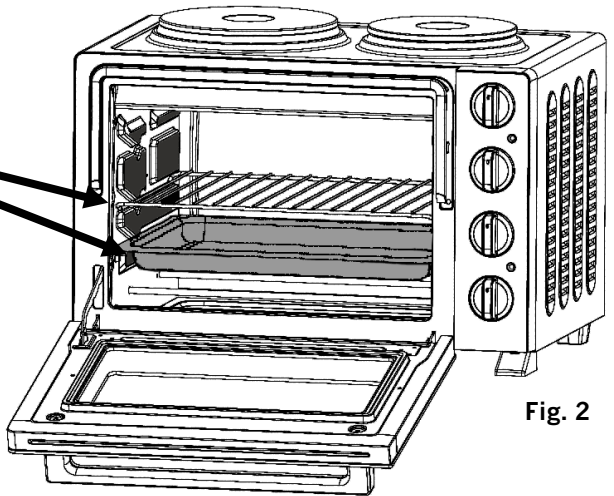

Fig. 2

Using the racks and other cooking vessels

- Food can be placed directly onto the grill and the baking tray supplied.
- If placing food directly onto the grill rack, fit the baking tray into the lower oven rack rest to act as a drip / crumb tray (fig 2 & 11).
- Always use the handle supplied when fitting or removing the rack / tray from the oven. See figs 3 & 4 below on how to fit the handle.

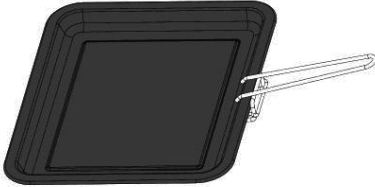

Fig. 3

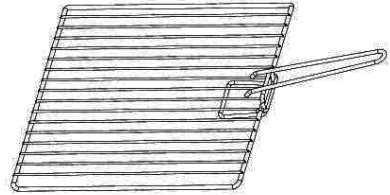
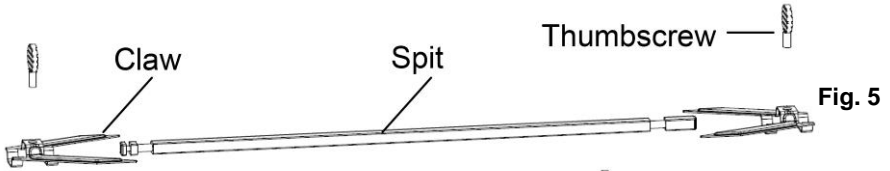

Fig. 4

- If using another cooking vessel
 - Always place the container onto the grill rack.
 - Ensure that it will fit into the oven cavity without touching the sides of the oven or the heating elements.
 - Ensure that the vessel is suitable for this type of oven e.g. Ferrite materials such as enamel, cast or stainless steel and heat resistant glass. **Do not use copper, aluminium, paper or plastic containers.**

Assembling and fitting the rotisserie spit



- Fit the claws onto the rotisserie spit with the claws facing inwards (figs. 5 & 6).
- Fit the thumb screws into the holes in the claws and turn until secure (fig. 6).
- Note that the spit has different shaped ends – see end 'A' and end 'B' in the diagram above. End A is fitted first into the socket on the right hand side of the oven before fitting end B into the bracket on the left hand side of the oven (fig. 7).

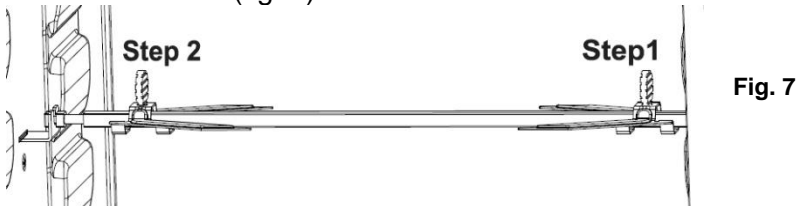

- Always use the rotisserie handle to remove the spit from the oven when hot. Place the hooked ends of the rotisserie handle under the spit and into the notches (figs 8 & 9) and lift out.

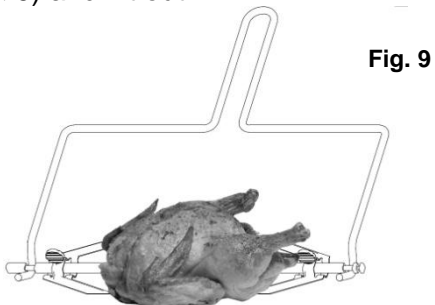
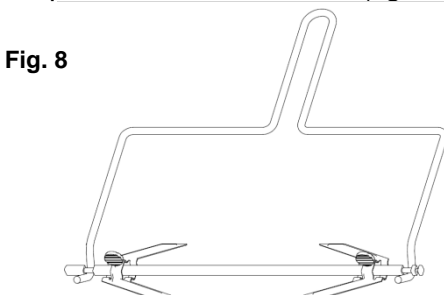

Basic oven operation

The oven can be used in a similar manner to a conventional and fan assisted electric oven to bake, roast and grill food. Fan assisted modes circulate heated air around the food with faster and more even cooking results and requires less cooking time. See food packaging for suitability for fan assisted cooking.

1. Place the oven on a stable, flat, heat resistant surface and away from any flammable materials. Check that the FUNCTION knob and both HOTPLATE knobs are in their OFF / □ positions.
2. Fit the crumb tray into the **base** of the oven.
3. Fully unwind the cable, plug in and switch on at the mains (no indicators should be lit). For safety do not allow the cable to dangle over the edge of units.
4. Turn the TEMPERATURE control knob and select the cooking desired cooking temperature (100 - 220°C).
5. Turn the FUNCTION control knob and select the desired cooking method – see section oven function (page 6).
6. The oven light and the oven indicator will illuminate to show that the cooker is now operational.
7. Open the oven door (fig 10) and place the food into the oven using the grill rack and / or baking tray (Fig. 11).

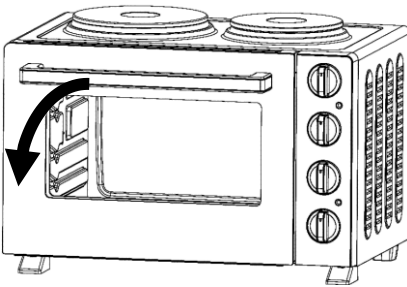

Fig. 10

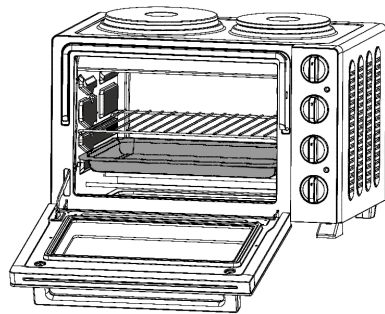

Fig. 11

8. If baking, roasting or using the fan assist modes, close the oven door.
9. If grilling or toasting leave the oven door ajar (fig. 12).

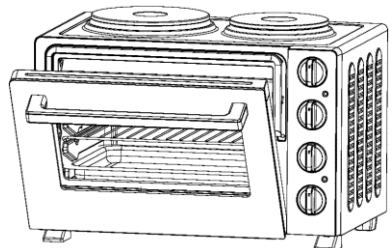

Fig. 12

Basic oven operation (continued)

10. When the cooking time has finished, turn the FUNCTION control knob to the off (□) position and remove the food.
11. The oven can be stopped at any time by turning the FUNCTION control knob to the off (□) position or by switching off at the mains.

Notes:

- When not in use, always ensure that the FUNCTION control knob is set to the off (□) position.

Tips for successful cooking

- Follow cooking instructions on food packaging.
- For more accurate timing, preheat the oven for a few minutes before placing food into the cavity for cooking.
- Turn or stir food some foods halfway through cooking process.
- Distribute food evenly across the grill rack and baking tray.
- The cooking time will vary according to the shape, thickness and composition of the food.
- Smaller pieces will cook quicker than larger pieces. For best results, ensure pieces of food are similar in size and thickness.

Hob use

The hotplates can be used in a similar manner to conventional electric hotplates to fry and boil food. The left hand hotplate is controlled using the upper HOTPLATE knob and has a higher rating (see table below). The right hand hotplate is controlled using the lower HOTPLATE knob.

1. Place the oven on a stable, flat, heat resistant surface and away from any flammable materials. Check that the FUNCTION control knob is at the off (□) position.
2. Fully unwind the cable, plug in and switch on at the mains (no indicators should be lit). For safety do not allow the cable to dangle over the edge of units.
3. Turn the HOTPLATE control knob for the hotplate of choice and select the desired hotplate power. The hotplate indicator will illuminate.

Hotplate	Position	Power (W)
 Left	1	400
	2	600
	MAX	1000
 Right	1	300
	2	450
	MAX	750

4. Place the food into a vessel suitable for an electric hob and fry or cook as required by your recipe.
5. To switch off the hotplate, turning the HOTPLATE control knob to 'OFF' or switch off at the mains. The hob indicator will extinguish.

Tips for efficient hob use

- Do not operate the hob for an extended time without a pan on the hotplate (fig. 13).



Fig. 13

- Use pans with flat bottoms (fig. 14). Uneven or thin bottomed pans will waste energy, are slow to cook, can rock and overbalance.



Fig. 14

- Use pans that are the same size or slightly larger than the hotplate (fig. 15). Smaller pans waste energy and oversized pans (>50mm overhang) can overheat the hob and cause cracks and damage.

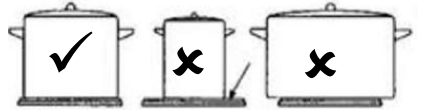

Fig. 15

- Ensure pan base is dry and avoid placing wet lids on hotplates (fig. 16).

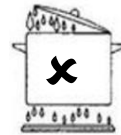

Fig. 16

Rotisserie operation

1. Place the oven on a stable, flat, heat resistant surface and away from any flammable materials. Check that the FUNCTION control knob is at the off (□) position.
2. Fully unwind the cable, plug in and switch on at the mains (no indicators should be lit). For safety, do not allow the cable to dangle over the edge of units.
3. Fit the crumb tray into the base of the oven.
4. Fit the baking tray into the **lowest** slot (not the base) of the oven so it can act as a drip tray or use to roast your vegetables at the same time.
5. Make a hole through the centre of the joint or chicken and insert the rotisserie spit.

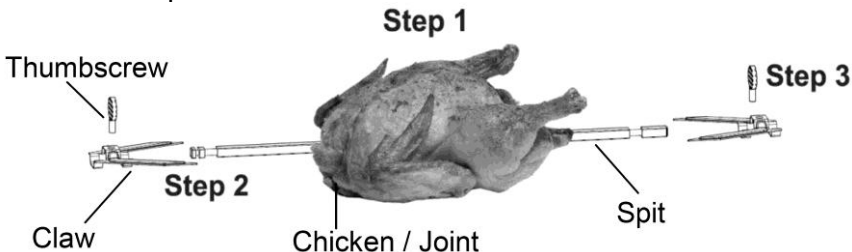

Fig. 17

6. Fit the claws onto the spit and ensure the spikes enter the joint / chicken. Secure the claws into position using the thumbscrews as these will ensure the joint rotates when the spit turns.
7. Insert the rotisserie spit and joint into the oven cavity and ensure that there is sufficient clearance for the food to rotate without touching the heating elements.
8. Close the oven door.
9. Turn the TEMPERATURE control knob and select temperature 220°C.
10. Turn the FUNCTION control knob and select the desired rotisserie option – see section oven function (page 6).
11. The oven light and the oven indicator will illuminate to show that the cooker is now operational and the spit will start to rotate.
12. When the cooking time has finished, turn the FUNCTION control knob to the off (□) position.
13. The oven can be stopped at any time by turning the FUNCTION control knob to the off (□) position or by switching off at the mains.
14. Using the rotisserie spit handle lift out the roast.

Rotisserie operation (continued)

Notes:

- The maximum weight of food that can be roasted using the rotisserie spit is 4.5kg
- The baking tray can be used to roast vegetables at the same time as acting as a drip tray.
- When not in use, always ensure that the FUNCTION control knob is set to the off (□) position.

Cleaning

Clean the oven, hob, rotisserie spit, grill rack, baking and crumb tray after each use.

1. Switch off and unplug the oven and allow the oven and the accessories to cool completely. Cleaning the oven whilst hot may cause glass door to shatter and risk personal injury.
2. Wipe external surfaces of the oven with a soft damp cloth and dry surfaces with a soft dry cloth.
3. Wipe internal oven surfaces with a soft damp cloth soaked in soapy water. Rinse and dry surfaces with a soft dry cloth.
4. Do not use strong detergents or abrasives, as these may dull or scratch the surface which may result in the glass door shattering. Do not immerse in water. Do not use a steam cleaner.
5. Slide and lift out the crumb tray from the bottom of the oven.
6. Wash loose parts (crumb tray, grill rack, baking tray and baking tray handle, rotisserie spit and handle) in hot water with a little washing up liquid. Rinse and dry thoroughly. Not suitable for the dishwasher.
7. Refit all parts.

Replacing the bulb

1. Switch off the oven, unplug from the mains supply and allow the oven to cool completely.
2. Carefully unscrew the glass cover (figs. 18 & 19) and place to one side.
3. Remove (unscrew) the spent bulb (figs. 19 & 20) and replace with one of the same type (Max 15W E14 (small Edison screw) incandescent oven bulb). Handle the new one carefully and screw in firmly, taking care not to cross threads. Always use the same or lower wattage bulb. Please use low energy bulbs where possible.
4. Refit the glass cover.

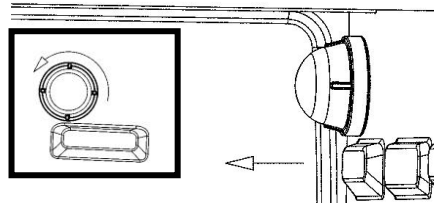

Fig 18

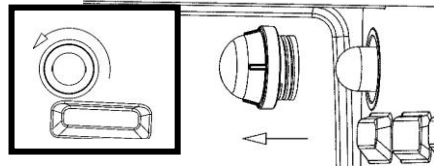

Fig 19

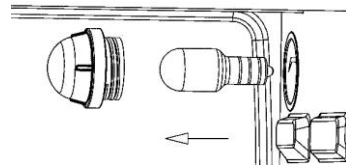

Fig 20

Technical specification

Morphy Richards 28 Litre Rotisserie Mini Oven with Hob		
Model	KH-J28RCL-E1Dkh	
Rated Voltage & Frequency	220 - 240V AC 50/60Hz	
Rated Power Input	Total	2850W
	Oven	1100
	Hotplates	1750
Capacity	Overall	28 litre
	Useable	22 litre
Replacement bulb type	Max 15 W E14 (SES) incandescent oven bulb	
Class rating	1 (earthed)	
BS 1362 fuse	13A	
Product dimensions (external)	505 x 405 x 347 mm	
Product weight (net)	12 kg approx.	



Recycling electrical products

You should now recycle your waste electrical goods and in doing so help the environment.

This symbol means an electrical product should not be disposed of with normal household waste. Please ensure it is taken to a suitable facility for disposal when finished with.

Visit www.recycle-more.co.uk, click on "bank locator" and enter your postcode to find your nearest recycling site.



Plug / Wiring advice

The wires in this mains lead are coloured in accordance with the following UK electrical code:

BLUE = NEUTRAL

BROWN = LIVE

GREEN + YELLOW = EARTH

Non-rewireable plug

This appliance may be fitted with a “non-rewireable” plug. If you need to change the fuse in a “non-rewireable” plug, the fuse cover must be refitted. If the fuse cover is lost or damaged, the appliance must not be used.

Rewireable plug

The colours of the wires in the mains lead of this appliance may not correspond with the coloured markings identifying the terminals in a rewireable plug. **Rewireable plugs should only be replaced by a suitably competent person. If in doubt, consult a qualified electrician.**

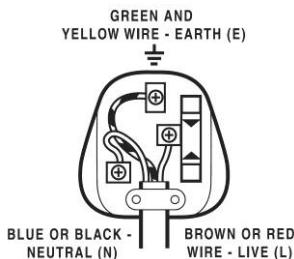

The BLUE wire must be connected to the terminal marked with the letter N

The BROWN wire must be connected to the terminal marked with the letter L

The GREEN & YELLOW wire must be connecting to the terminal marked with the letter E or the earth symbol

www.morphyrichards.com

Imported by Argos Ltd, MK9 2NW

If you require assistance, please call the Sainsbury's Argos helpline on 0345 604 0105

Your statutory rights are not affected.

Made in China. All brand names are registered trademarks of their respective owners.



PRODUCT GUARANTEE

This product is guaranteed against manufacturing defects for a period of



Year

This product is guaranteed for twelve months from the date of original purchase.

Any defect that arises due to faulty materials or workmanship will either be replaced, refunded or repaired free of charge where possible during this period by the dealer from whom you purchased the unit.

The guarantee is subject to the following provisions:

- The guarantee does not cover accidental damage, misuse, cabinet parts, knobs or consumable items.
- The product must be correctly installed and operated in accordance with the instructions contained in this manual. A replacement copy of this instruction manual can be obtained from www.argos-support.co.uk
- It must be used solely for domestic purpose.
- The guarantee will be rendered invalid if the product is re-sold or has been damaged by inexpert repair.
- Specifications are subject to change without notice.
- The manufacturer disclaims any liability for the incidental or consequential damages.
- The guarantee is in addition to, and does not diminish your statutory or legal rights.

Guarantor: Argos Ltd
489 - 499 Avebury Boulevard
Central Milton Keynes
MK9 2NW
www.argos-support.co.uk