

# cookworks

## Espresso Machine

Model No. CM8500A-GS



## Care & Instruction Manual

For household and indoor use only

Please read these instructions before use and retain for future reference



## ELECTRICAL SAFETY

- You should only plug the appliance into a 220V-240V AC, 50Hz supply. Connecting it to other power sources may damage the appliance and will invalidate the guarantee.
- Switch off and unplug when not in use and before cleaning the appliance.
- Keep the appliance and its cord out of reach of children less than 8 years.
- Do not allow children to use the appliance without supervision.
- This appliance can be used by children aged from 8 years and above and persons with reduced physical, sensory or mental capabilities or lack of experience and knowledge if they have been given supervision or instruction concerning use of the appliance in a safe way and understand the hazards involved. Children shall not play with the appliance. Cleaning and user maintenance shall not be made by children unless they are older than 8 and supervised.
- Keep cable, plug and outside of espresso machine dry and away from areas where it is likely to get splashed. Never immerse in water.
- Do not pull on the cable to disconnect from the mains supply.
- Do not operate the appliance if damaged or after it malfunctions. In the event the supply cord is damaged, in order to avoid a hazard it must only be replaced by a qualified service engineer, with a suitably approved part.
- This appliance must be positioned so that the plug is accessible and the plug socket is within easy reach of the power cord.
- This appliance must be plugged in to an earthed socket outlet.

## **WARNING!**

- This appliance is intended exclusively for use in domestic households. It is not suitable for commercial use.
- Hot liquid or steam is emitted from the brewing head and steam nozzle during operation and descaling.
- Do not cover and allow the espresso machine to cool fully before storing.
- The surfaces of the filter holder and steam nozzle will become hot during and immediately after use. Do not touch and always use the handle.
- Do not use the espresso machine near or under surfaces that are heat sensitive or those that may be damaged by steam.
- Use only with the parts provided and to make hot beverages. This appliance can cause personal injury if misused.

## Parts

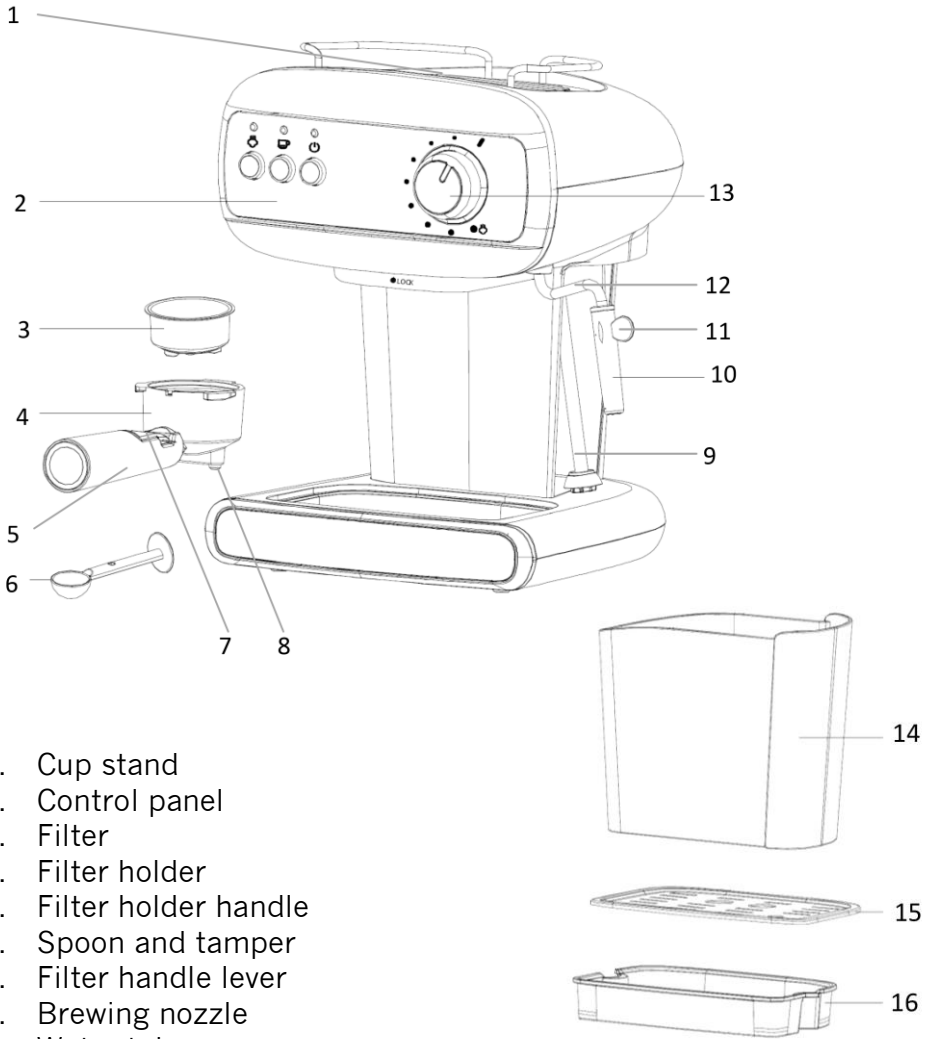

1. Cup stand
2. Control panel
3. Filter
4. Filter holder
5. Filter holder handle
6. Spoon and tamper
7. Filter handle lever
8. Brewing nozzle
9. Water tube
10. Steam nozzle cover
11. Steam nozzle handle
12. Steam nozzle
13. Steam control knob
14. Water tank
15. Cup shelf
16. Drip tray

## PARTS – CONTROL PANEL

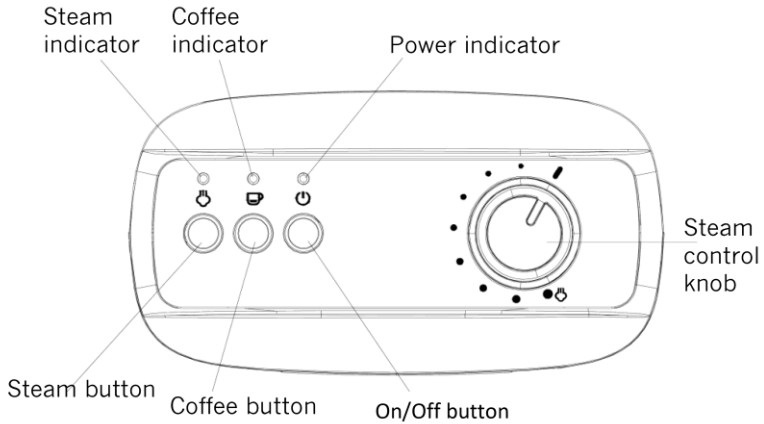

### WATER TANK REMOVAL AND FILLING

1. Slide out the water tank from the body of the espresso machine (fig. 1)
2. Fill with water taking care not to fill past the 'max' mark on the tank.
3. Place the water tube into the water tank before sliding the water tank into the espresso machine.



Fig. 1

## FITTING AND FILLING THE FILTER

1. Align the small lug on the edge of the filter with the notch on the rim of the filter holder (fig.2) and then insert the filter into the holder.
2. Rotate the filter a small way to help prevent the filter from falling out of the filter when emptied (fig.3).

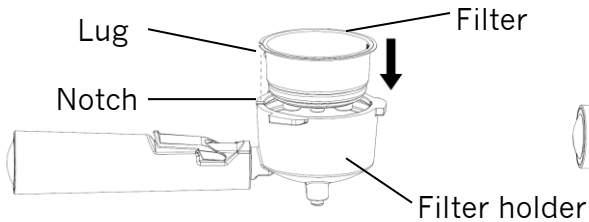

Fig. 2

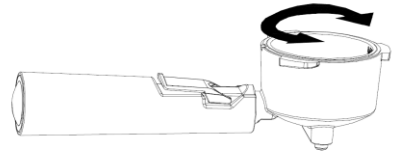

Fig. 3

1. Using the spoon supplied, fill the filter with **fresh ground coffee** (fig. 4).
2. Pack it lightly using the tamper at end of the spoon (fig. 5). One spoonful of coffee is usually sufficient for most people. When packed the coffee should not be above the MAX line marked on the filter.

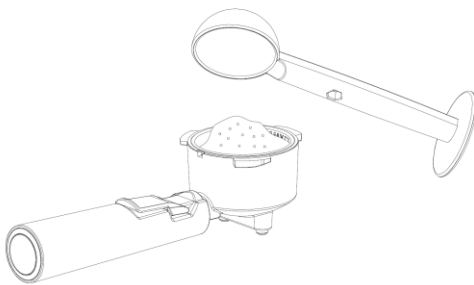

Fig. 4

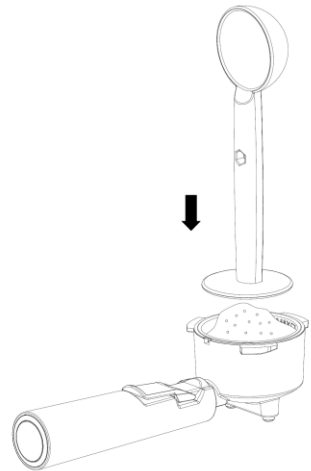

Fig. 5

## PREPARATION FOR USE

### Before using the espresso machine for the first time.

It is important to thoroughly clean the appliance before first use.

1. The espresso machine comes fully assembled but without the filter and the holder fitted.
2. Place the espresso machine on a stable, flat, heat resistant surface and away from surfaces that may be damaged by steam.
3. **Remove all tape** used for product transit.
4. Slide out the water tank and fill with water. Do not fill past the 'max' mark on the tank. Insert the water tube and then refit the water tank.
5. Fit the filter into the filter holder
6. Offer the filter holder to the brewing head and align the handle with 'insert' marked at the side of the appliance (fig. 6).
7. Move the handle firmly to the right (fig 7) until it is aligned with the position marked 'lock' on the front face (fig. 8).



Fig. 6

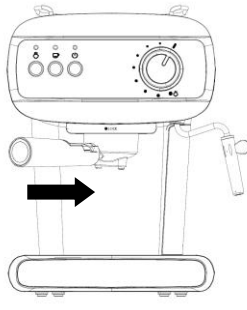

Fig. 7

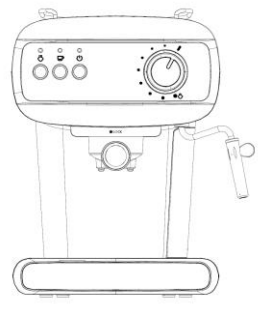

Fig. 8

8. Place a jug or similar onto the cup shelf directly underneath the brewing nozzles of the filter holder.
9. Ensure that the steam knob is aligned with the off '☐' position.
10. Check that all buttons are in their raised (off) position.
11. Fully unwind the cable, plug in and switch on. For safety do not allow the cable to dangle over the edge of units.

12. Press the ON/OFF (🔌) button to turn the machine on and the red power indicator will illuminate. The appliance will start to heat up.
13. When the coffee indicator illuminates (green) the espresso machine is ready to operate.
14. Press the coffee (☞) button and then allow the water to flow for one minute. A spluttering sound maybe heard for a few seconds as the water purges the air from the lines.
15. Press the coffee (☞) button again to stop the flow of liquid.
16. Discard the water remaining in the tank and in the jug.
17. The espresso machine is now ready for use.

## TO USE – MAKING ESPRESSO

A hotter more flavoursome coffee will be achieved if the espresso machine is pre-heated before making the first cup of coffee.

1. To preheat the espresso machine, follow the 'Preparation for use' directions on the previous page. Discarding the equivalent of two espresso cups (200ml approx.) of water.
2. When step 15 has been completed, remove the filter holder and fill the filter with **fresh ground coffee** and packed lightly using the tamper supplied. One spoonful of coffee is usually sufficient for most people.
3. Remove any excess coffee from the rim of the filter holder before refitting the filter holder to the espresso machine as before.
4. Place your coffee cup onto the cup shelf directly underneath the brewing nozzles.
5. Press the coffee (☞) button and after a short while the coffee will flow. During the brewing process it is normal for the green coffee indicator to go on and off as the heater activates.
6. When the desired quantity of coffee is obtained or the colour of the coffee starts to lighten, press the coffee (☞) button to stop the flow. Remove the coffee cup.



7. Remove the filter holder from the espresso machine. Lift the lever on the filter holder handle and with your thumb hold the lever firmly against the side of the filter holder. Pour / tap out the coffee, the lever should prevent the filter falling into the bin when inverted.
8. When the last cup of coffee has been made, switch off the espresso machine off by pressing the ON/OFF (☺) button

Notes:

- Do not use without the drip tray fitted. A small amount of liquid back flows into the drip tray after each cup of coffee made. **Empty the drip tray regularly and when the float becomes visible through the cup shelf.**
- For best results always use fresh cold water in the espresso machine and freshly ground beans. Serve coffee immediately after brewing.
- The espresso machine will automatically switch off after 25 minutes of being switched on.

## TO USE – USING THE STEAM NOZZLE

1. Place the espresso machine on a stable, flat, heat resistant surface and away from surfaces that may be damaged by steam.
2. Fill the water tank and ensure the cover is fitted onto the steam nozzle.
3. Fully unwind the cable, plug in and switch on. For safety do not allow the cable to dangle over the edge of units.
4. Press the ON/OFF (☺) button to turn the machine on and wait for the coffee indicator to illuminate (green).
5. Press the steam (☺) button and wait for the steam indicator to illuminate (green).
6. Place the cold milk (or other beverages to be heated) into a suitable container (see note section on following page).
7. Position the container under the nozzle so that the nozzle is approximately halfway into the milk.
8. Move the steam control knob slowly towards the steam symbol (☺) and after a short while the steam will flow and the milk will begin to froth. As the froth is generated, move the container so that the nozzle moves through the milk but **always ensure the nozzle is below the surface.**
9. When the milk is hot and sufficient froth has been generated, turn the steam control knob back to the '☺' position. Keep the steam nozzle beneath the surface of the milk (to prevent splattering) until the steam has stopped flowing.
10. When the steam nozzle has been used for the final time, switch off the espresso machine by pressing the ON/OFF (☺) button.
11. To prevent steam nozzle clogging, remove and wash the nozzle cover and wipe the steam nozzle tip with a damp cloth.

## Notes:

- Milk expands when frothed. Use a wide necked jug that holds at least double the volume of the cold milk.
- Whole milk will generate creamier and stiffer foam than semi skimmed milk.
- Do not bring the milk to the boil (this will happen if large bubbles start to form on the surface of the milk).
- Cappuccino is usually made from  $\frac{1}{3}$  espresso coffee,  $\frac{1}{3}$  steamed milk and  $\frac{1}{3}$  froth, although the proportions can be varied according to personal taste and a little cocoa powder may be sprinkled on top.

## **CLEANING & DESCALING**

To maximize the efficiency of the espresso machine, clean, descale and empty the drip tray regularly.

### **General cleaning**

1. Switch off and unplug the espresso machine and allow the appliance to cool completely.
2. Wash loose parts (filter holder, filter, steam nozzle cover, cup shelf and drip tray) in hot water with a little washing up liquid. Rinse and dry thoroughly. Not suitable for the dishwasher.
3. The water tank can be rinsed with clean water and the outside wiped with a soft damp cloth.
4. Wipe external surfaces of the espresso machine with a soft damp cloth and dry surfaces with a soft dry cloth. Do not use detergent or abrasives as these may scratch the surface. Never immerse in water.

## Filter cleaning

For a more intensive filter clean

1. Turn the filter upside down.
2. Twist the locking disc anticlockwise (fig. 9) and separate into the two parts shown (fig. 10).
3. Press on the centre of the capsule assembly (fig. 10) and again separate into the two parts shown (fig. 11).
4. Finally remove the seal and separate the filter disc from its support (fig.12).

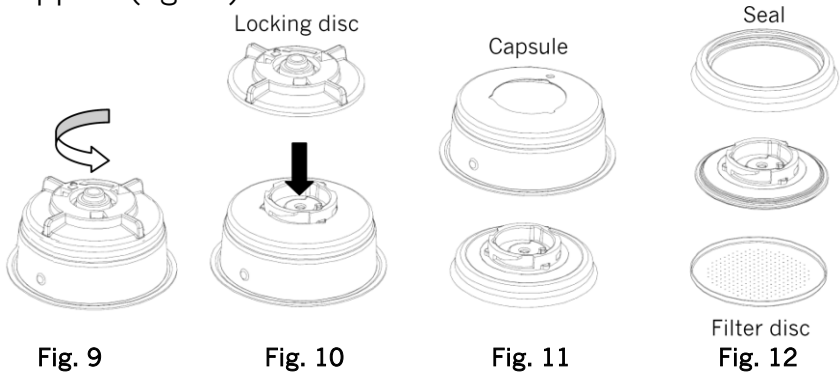

5. Clean all parts in hot water with a little washing up liquid. Rinse and dry thoroughly before reversing the above steps. Not suitable for the dishwasher.

## Descaling

Descale with a proprietary descaler suitable for espresso machines and dilute in accordance with the instructions on the pack.

1. Fill the water tank to the MAX level with the descaler solution.
2. Plug in, and check that the steam control knob and all buttons are in their off position. Fit an empty filter and filter holder.
3. Switch on using the ON/OFF (⏻) button and wait for the green coffee indicator to illuminate.
4. Place a jug under the brewing nozzles and then press the coffee (☞) button. Allow approximately 2 espresso cups (200ml approx.) of the liquid to flow from the brewing nozzles.
5. Press the coffee (☞) button again to turn off this function and now place the jug under the steam nozzle with the tip below the surface of the liquid.
6. After a few seconds, press the steam (☞) button, and when the green indicator has illuminated allow steam to flow for about a minute.
7. Press the steam (☞) button again, to turn off this function
8. Switch off the espresso machine using the ON/OFF (⏻) button and allow the descaler solution to stay in the espresso machine for **15 minutes**.
9. Restart the espresso machine and repeat steps 3–7 a further four times.
10. Discard any remaining descaling solution in the water tank. Rinse the tank thoroughly with clean water and refill to the max line.
11. Repeat steps 3–7 above a further three times to ensure pipe work is thoroughly flushed.
12. The espresso machine is now ready for use.

## TROUBLE SHOOTING

Observation	Comment / action
Espresso leaking from the filter holder	Check that the filter holder is inserted correctly and it is in the correct 'lock' position.
	Coffee powder not cleaned off the edge of the filter holder.
Espresso does not come out	No water or not enough water in the water tank.
	No coffee in the filter
	Filter clogged because coffee is ground too fine or packed too tightly.
Steam does not come out of the steam nozzle	No water or not enough water in the water tank.
	Steam nozzle clogged.
	Steam temperature indicator not lit.
Insufficient froth generated	No water or not enough water in the water tank.
	Steam nozzle position in the milk is incorrect. Move nozzle up and down in milk when frothing.
	Use whole or semi skimmed milk

## TECHNICAL SPECIFICATION

Cookworks Espresso Machine	
Model	CM8500A-GS
Cat No	9513055
Rated Voltage & Frequency	220 – 240V AC 50 – 60Hz
Rated Power Input	850W
Class rating	1 (earthed)
BS 1362 fuse	10A
Tank capacity	1.25 litre
Product dimensions (external)	225 x 268 x 312 mm
Product weight (net)	2.9 kg approx.



## RECYCLING ELECTRICAL PRODUCTS

You should now recycle your waste electrical goods and in doing so help the environment.

This symbol means an electrical product should not be disposed of with normal household waste. Please ensure it is taken to a suitable facility for disposal when finished with.

Visit [www.recycle-more.co.uk](http://www.recycle-more.co.uk), click on “bank locator” and enter your postcode to find your nearest recycling site.



## PLUG / WIRING ADVICE

The wires in this mains lead are coloured in accordance with the following UK electrical code: BLUE = NEUTRAL  
BROWN = LIVE  
GREEN + YELLOW = EARTH

### Non-rewireable plug

This appliance may be fitted with a “non-rewireable” plug. If you need to change the fuse in a “non-rewireable” plug, the fuse cover must be refitted. If the fuse cover is lost or damaged, the appliance must not be used.

### Rewireable plug

The colours of the wires in the mains lead of this appliance may not correspond with the coloured markings identifying the terminals in a rewireable plug. **Rewireable plugs should only be replaced by a suitably competent person. If in doubt, consult a qualified electrician.**

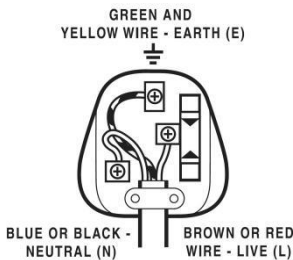

The BLUE wire must be connected to the terminal marked with the letter N

The BROWN wire must be connected to the terminal marked with the letter L

The GREEN & YELLOW wire must be connecting to the terminal marked with the letter E or the earth symbol .

Produced in China.

Argos Limited, 489-499 Avebury Boulevard,  
Milton Keynes, MK9 2NW.

Argos (N.I.) Ltd, Forestside Shopping Centre,  
Upper Galwally, Belfast, United Kingdom, BT8  
6FX.

Argos Distributors (Ireland) Limited, Unit 7,  
Ashbourne Retail Park, Ballybin Road,  
Ashbourne, County Meath, Ireland

[www.argos.co.uk/cookworks](http://www.argos.co.uk/cookworks)

Tel: 0345 640 3030





## PRODUCT GUARANTEE

This product is guaranteed against manufacturing defects for a period of



Year

This product is guaranteed for twelve months from the date of original purchase.

Any defect that arises due to faulty materials or workmanship will either be replaced, refunded or repaired free of charge where possible during this period by the dealer from whom you purchased the unit.

The guarantee is subject to the following provisions:

- The guarantee does not cover accidental damage, misuse, cabinet parts, knobs or consumable items.
- The product must be correctly installed and operated in accordance with the instructions contained in this manual. A replacement copy of this instruction manual can be obtained from [www.argos-support.co.uk](http://www.argos-support.co.uk)
- It must be used solely for domestic purpose.
- The guarantee will be rendered invalid if the product is re-sold or has been damaged by inexpert repair.
- Specifications are subject to change without notice.
- The manufacturer disclaims any liability for the incidental or consequential damages.
- The guarantee is in addition to, and does not diminish your statutory or legal rights.

Guarantor: Argos Ltd  
489 - 499 Avebury Boulevard  
Central Milton Keynes  
MK9 2NW  
[www.argos-support.co.uk](http://www.argos-support.co.uk)