

BUSH

Instruction manual

Bush 28.8V cordless handstick vacuum cleaner

Model: V18P01EP29EU



You'll soon be enjoying your new Bush 28.8V cordless handstick vacuum cleaner.

It all begins here, with your instructions. Don't worry, there's nothing too technical coming up. Just simple, step-by-step guidance to get you up and running quickly. Sound good? Then let's get started.

Help and Guidance

We're here to help you get the most from your Bush 28.8V cordless handstick vacuum cleaner.

Should you require any guidance; call our Help line on 0345 604 0105.

Further contact details can be found online at: www.bush-support.co.uk

If you require any technical guidance or find that your product is not operating as intended, a simple solution can often be found in the **Troubleshooting** section of these instructions

Contents

1	Safety information	
	Power source	6
	Ventilation heat and moisture	7
	Warning	7
	Battery safety	8
2	Getting to know your vacuum cleaner	
	Accessories	10
	Part identification	11
	Charging the vacuum	12
3	Assembling your vacuum cleaner	
	Wall mounting	14
	Assembly	16
4	Using your vacuum cleaner	
	Getting started	20
	Nozzle use	20
5	Care and maintenance	
	Maintenance	22
	Emptying the dust container	22
	Cleaning the filters	23
	Cleaning the brush	25
	Technical specification	26
6	Product support	
	Troubleshooting	28
	Help and assistance	29
	Guarantee	30

If you require any technical guidance or find that your product is not operating as intended, a simple solution can often be found in the **Troubleshooting** section of these instructions

Safety information 1





Safety information

Important - Please read these instructions fully before assembling or operating

Power source

- For household and indoor use only
- Keep the appliance and its cord out of reach of children less than 8 years.
- Do not allow children to use appliance without supervision.
- This appliance can be used by children aged from 8 years and above and persons with reduced physical, sensory or mental capabilities or lack of experience and knowledge if they have been given supervision or instruction concerning use of the appliance in a safe way and understand the hazards involved. Children shall not play with the appliance. Cleaning and user maintenance shall not be made by children unless they are aged from 8 years and above and supervised.
- Do not pull on the charge cable to disconnect from mains supply.
- Fully unwind the charge cable before plugging in and ensure the cable is positioned away from areas where it is likely to get damaged or cause a trip hazard.
- The output cord of this mains adaptor cannot be replaced. In the event of damage to the cable, jack plug or adaptor, the entire adaptor unit should be replaced.
- Connections must only be made via the mains adaptor supplied, never connect the appliance directly to the 240v mains supply.
- Never use the adaptor supplied with any other appliance.

If you require any technical guidance or find that your product is not operating as intended, a simple solution can often be found in the **Troubleshooting** section of these instructions



Safety information

Important - Please read these instructions fully before assembling or operating

- Remove mains adaptor from supply if appliance is unused for a long period of time, and during thunderstorms.
- Switch off and unplug when not in use and remove the battery before emptying, cleaning or servicing the appliance. Servicing of this appliance must only be carried out by a qualified electrician.
- When the battery is fully charged, disconnect the appliance from power socket. Do not use 'lockable' sockets or permanently wire the appliance to mains.

Ventilation, heat and moisture

- Keep the appliance, battery, charge cable and mains adaptor plug dry and away from areas where it is likely to get splashed. Avoid using in hot, humid environments.
- CAUTION: The extension tube, floor head and the vacuum cleaner contain electrical connections, do not immerse in water for cleaning or use it to suck up liquids.
- The mains adaptor will become warm in use; do not cover or place on or near surfaces that could be affected by heat such as table tops and carpets.

Warning!

- Entrapment hazard - Do not place fingers or other objects near the rotating brush of the floor head or into the nozzles when the vacuum cleaner is in use. Always remove the floor head before carrying out cleaning and maintenance.
- Do not run the appliance off the edge carpets and rugs with fringes.

Or by calling one of our experts on **0345 604 0105**



Safety information

Important - Please read these instructions fully before assembling or operating

- Do not use the appliance to pick up burning or hot objects (e.g. coal, ash, cigarettes etc) of any kind.
- Do not cover the appliance or restrict air vents.
- Do not use the appliance to pick up sharp objects (e.g. pins, nails, tacks, staples etc) or string.

Battery safety

This vacuum cleaner has a rechargeable battery(Li-ion 28.8V 2000mAh).

- Never try to dismantle the vacuum cleaner.
- Do not short-circuit the supply terminals.
- Dispose of the vacuum cleaner responsibly at local authority household waste recycling facility.
- **DO NOT** dispose of the vacuum cleaner in a fire as the battery may explode or leak.

1. CAUTION-Danger of explosion if battery is incorrectly fitted/replaced
2. Only use the battery supplied in this appliance
3. Be sure to insert battery correctly taking care to observe the correct polarity (+ and -)
4. Battery should be replaced by an adult
5. Remove battery from the product before long-term storage

If you require any technical guidance or find that your product is not operating as intended, a simple solution can often be found in the **Troubleshooting** section of these instructions

Getting to know your vacuum 2



Getting to know your vacuum

You'll be up and running in no time

Ready? Let's begin...

Please read these instructions carefully. They contain important information which will help you get the best from your vacuum and ensure safe and correct installation and operation.

If you require any further assistance, our technical experts are happy to help. For full details, refer to the product support section at the end of these instructions.

Accessories

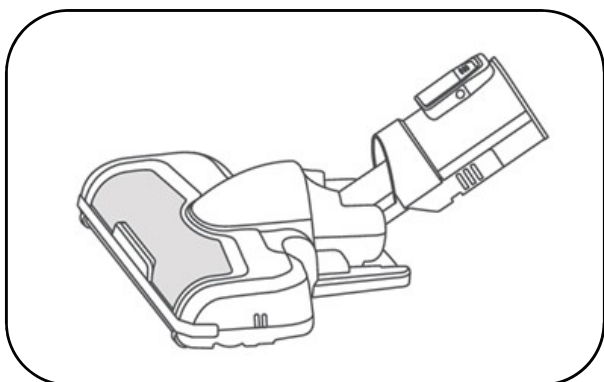

Floor head

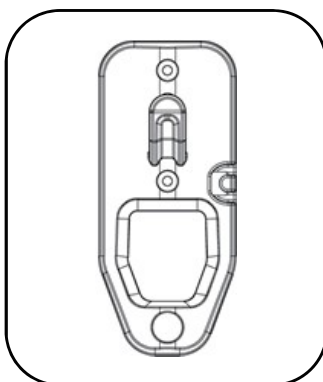

wall bracket

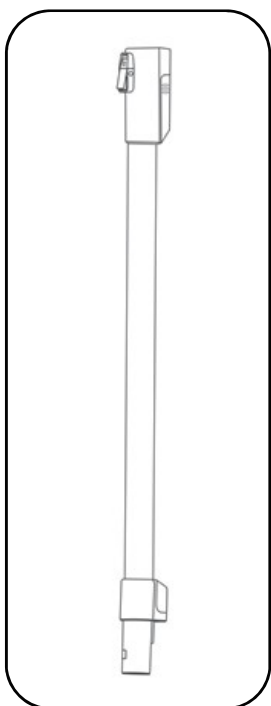

Extension tube

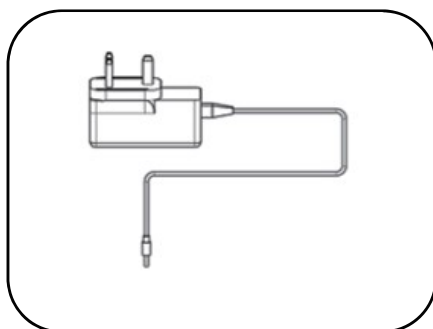

Adaptor / charger

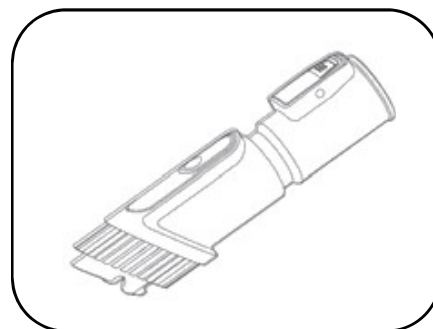

Combination nozzle

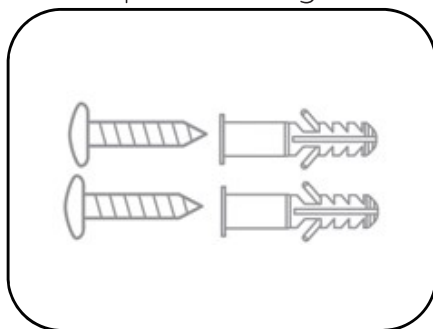

Wall fixings

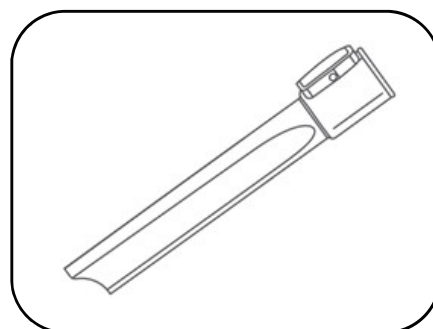

Crevice nozzle

If you require any technical guidance or find that your product is not operating as intended, a simple solution can often be found in the **Troubleshooting** section of these instructions

Getting to know your vacuum

You'll be up and running in no time

Part identification

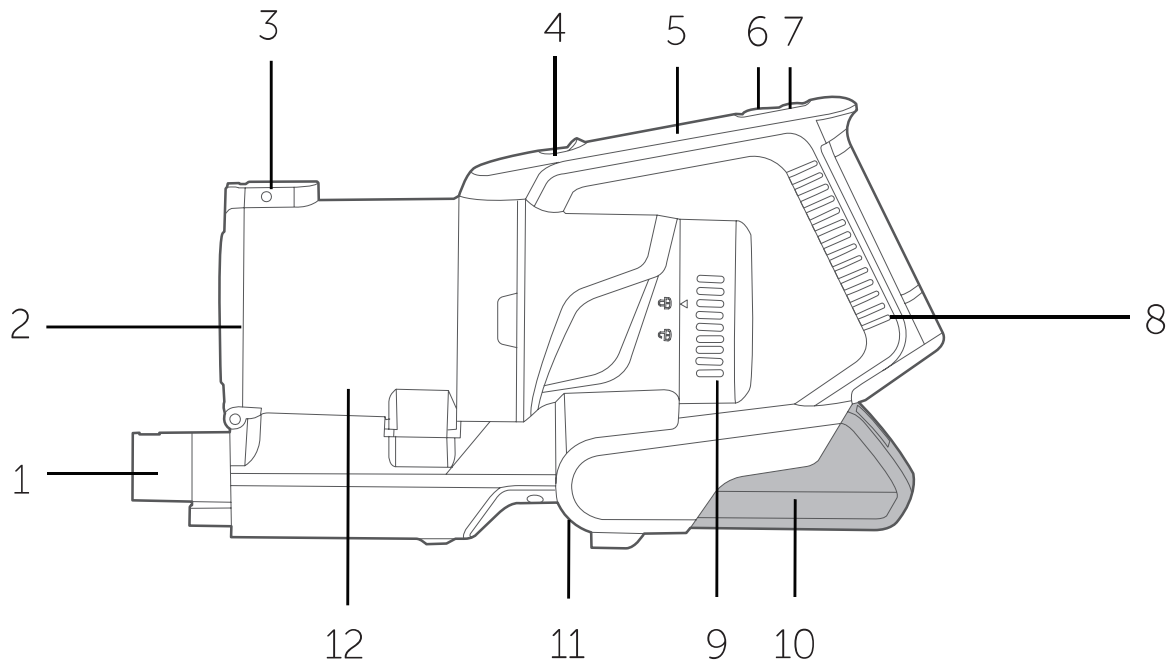

- | | | | |
|---|-------------------------------|----|---------------------|
| 1 | Accessory attachment point | 7 | Power on/off button |
| 2 | Bottom lid | 8 | Handle |
| 3 | Dust release button | 9 | Filter cover |
| 4 | Dust container release button | 10 | Battery pack |
| 5 | Battery indicator light | 11 | Easy rest nook |
| 6 | Speed control button | 12 | Dust container |

Or by calling one of our experts on **0345 604 0105**

Getting to know your vacuum

You'll be up and running in no time

Charging the Vacuum

This cleaner uses a rechargeable 28.8V Lithium battery suggest to charge fully before using for the first time. It takes 4-6 hours, and the vacuum can be used 10 mins with High Mode, 25 mins with Middle Mode, 50 mins with low mode.

1. Place the body of the cleaner onto a flat surface either a table or fit into the wall bracket.

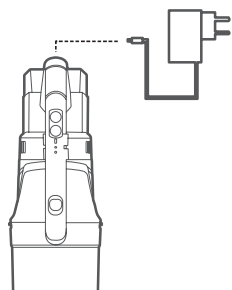

Fig. 1

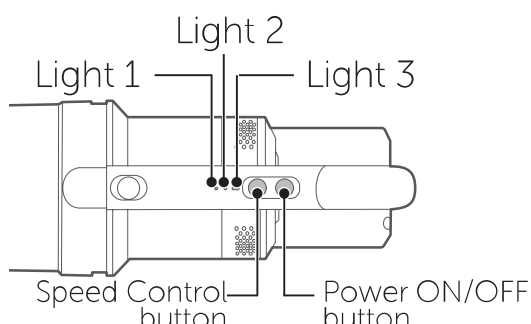

Fig. 2

2. Insert the adaptor cord into the DC jack at the end of the cleaner handle and plug the adaptor into the mains supply socket (fig.1).
3. It defaults to the Middle mode when powered on with a full battery (Light 1, 2, and 3 are on simultaneously).
Press the "Speed control button" once for High Speed (Light 1 and 2 is on and Light 3 is blue), and press the "Speed control button" again for Low Speed (Light 1 and 2 is on and Light 3 is off); (Fig 2)
The light indicator show the status (Fig 2):
Charging: Light 1 flash, light 2 off
Half charged: Light 1 on, light 2 flash
Fully charged: light 1 & 2 on, then off in 10 mins
Low battery: light 1 flash, light 2 off

Notes

- Light indicator 1 (Fig 2) will flash when cleaner is running at low battery and needs to be recharged, If recharge not started, the vacuum will power off.
- Only charge or recharge the vacuum indoors.
- Don't use and store the batteries under 5°C or above 40°C.
- Batteries become hot after heavy use and will become difficult to charge. Allow to cool down and wait about an hour before recharges.

If you require any technical guidance or find that your product is not operating as intended, a simple solution can often be found in the **Troubleshooting** section of these instructions

Assembling your vacuum 3



Assembling your vacuum

Bringing it all together

Wall mounting (Ref to the Wall mounting & fixings guide on page 18)

- Safety**
- Before drilling into wall surface, check for hidden cables or pipes.
 - Wear safety goggles and dust mask when drilling.
 - The use of a residual current device (RCD) is recommended when working with power tools.

- Tools required**
- Drill fitted with a 6mm masonry drill bit
 - Screwdriver
 - Pencil
 - Ruler
 - Spirit level

1. Choose a suitable location for the wall bracket away from areas where it will get wet or knocked and close to a socket. Check that the charge cable will reach the mains socket (180cm distance max) and that there is sufficient space above and below the bracket (approx. 120-125cm below) for the fully assembled vacuum cleaner be inserted. No part of the vacuum cleaner should touch the floor after fitted into the bracket (fig 6).

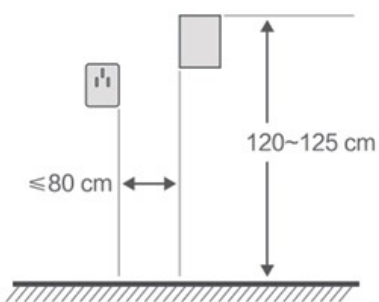

Fig. 4

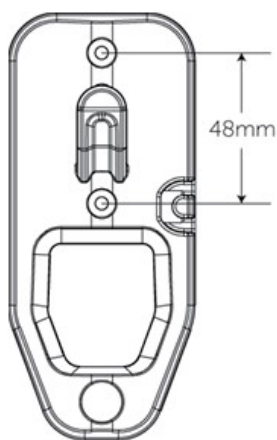

Fig. 5

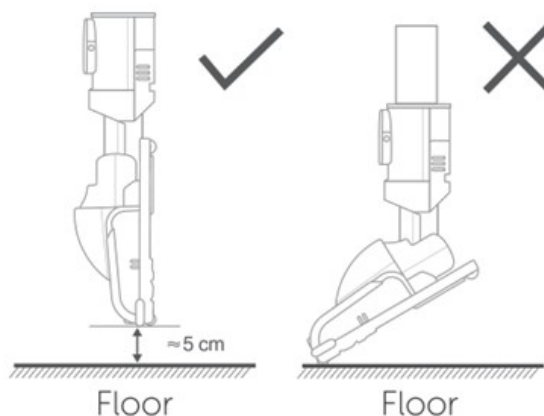

Fig. 6

If you require any technical guidance or find that your product is not operating as intended, a simple solution can often be found in the **Troubleshooting** section of these instructions

Installing your vacuum

Bringing it all together

2. Place the bracket in the desired position and using a pencil, mark the position for the two screw holes. Using a ruler, draw a line joining the points marked for the two screws and using a spirit level, check that it is on the same level.
3. If fixing to a masonry wall, use a masonry drill bit, drill holes to a depth of 30mm and insert the wall plugs.
4. If fixing to ceramic tiles, use a tile and glass drill bit to drill through the tile and then drill holes to a depth of approximately 32 mm using a masonry drill bit. Insert the wall plugs beyond the depth of the tile.
5. Hold the bracket into position, align the fixing holes in the bracket with the wall plugs and insert the screws until the bracket is held firmly into position
6. Insert the assembled vacuum cleaner into the bracket (fig.7).

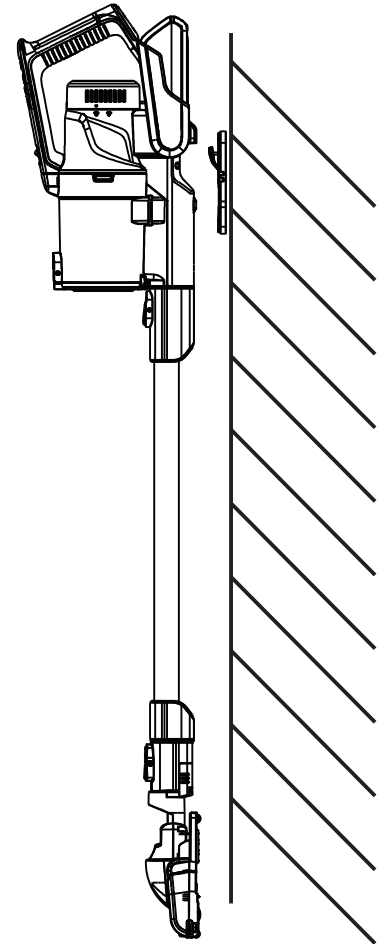

Fig. 7

Notes:

- If fixing the bracket to timber, follow the directions above, but only drill a small pilot hole for each screw and do not use wall plugs. This fitting is not suitable for mounting onto doors.
- If fixing to hollow plasterboard walls, use a drill bit suitable for wood and use wall anchors suitable for cavity walls. For maximum strength locate into wall studs and cross braces if possible.

Installing your vacuum

Bringing it all together

Assembly

1. Insert the extension tube onto the body of the vacuum as shown (fig. 8) and push to secure, a click will be heard.
2. Push the floor head onto the extension tube (fig. 8), a click will be heard. The crevice nozzle and combination nozzle can be fitted in place of the floor head.

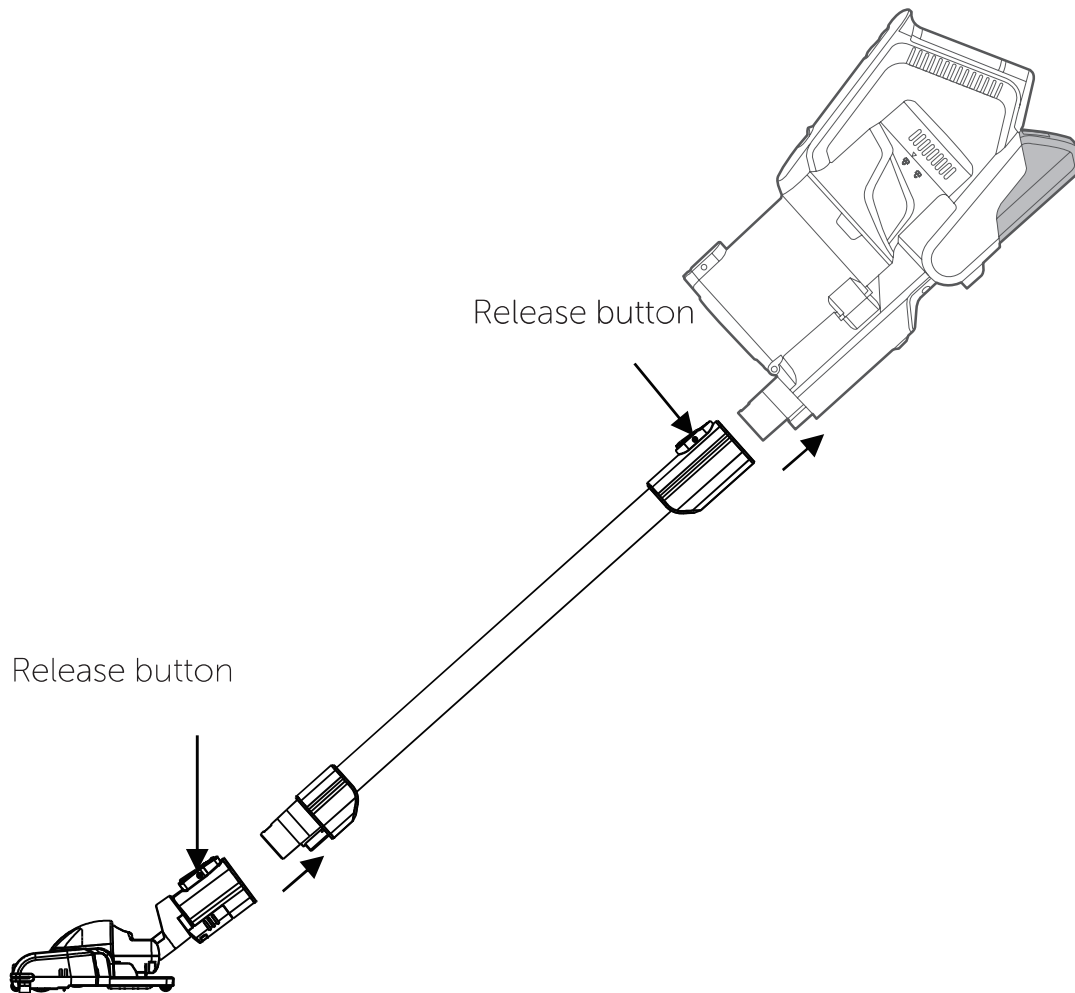

Fig. 8

If you require any technical guidance or find that your product is not operating as intended, a simple solution can often be found in the **Troubleshooting** section of these instructions

Installing your vacuum

Bringing it all together

3. Alternatively **DO NOT USE** the extension tube and fit the crevice nozzle or combination nozzle directly onto the body of the vacuum cleaner (fig. 9). The floor head can be fitted in a similar manner, but if using in this configuration ensure hands are kept away from the floor head during operation – due to a potential entrapment hazard.

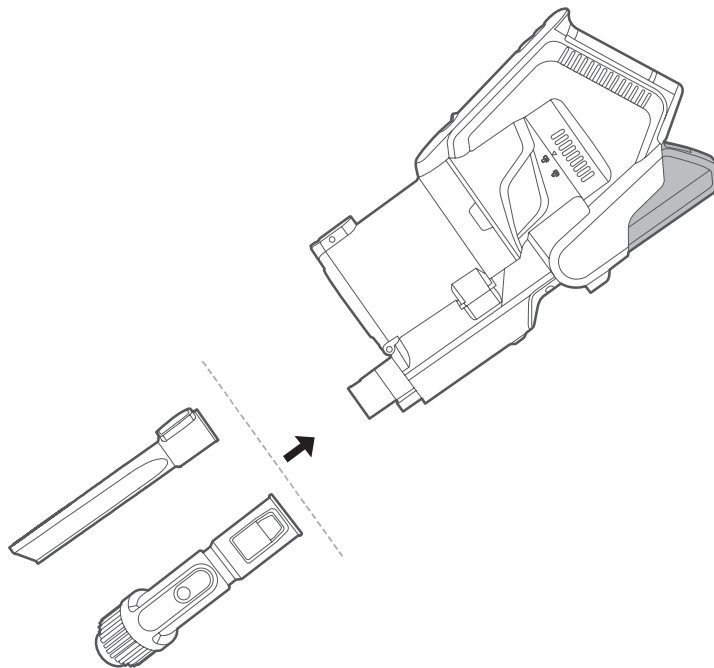

Fig. 9

4. Insert the battery pack and a click will be heard when correctly engaged.
5. To remove the all parts press the release button and accessories firmly pull apart.
6. To remove the battery, press the battery release button and firmly pull the battery from the body of the cleaner(Fig 10)

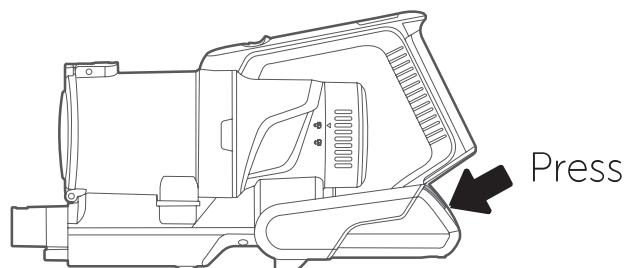
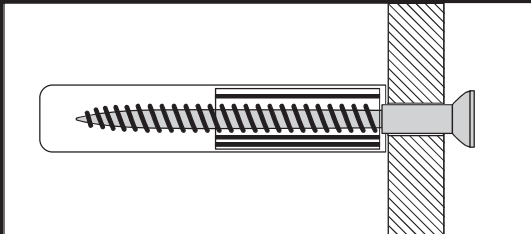

Fig 10

Wall Mounting & Fixings



IMPORTANT:

When drilling into walls always check that there are no hidden wires or pipes etc. Make sure that the screws and wall plugs being used are suitable for supporting your unit. Consult a qualified tradesperson if you are unsure.

HINTS:

- 1) General Rule  Always use a larger screw and wall plug if you are not sure.
- 2) Ensure you use the recommended drill bit to match the wall plug and hole size.
- 3) Ensure you drill the hole horizontally, do not force the drill or enlarge the hole.
- 4) Take extra care when drilling high walls, ceilings and ceramic tiles. Ensure the plug is fitting below the ceramic tile to avoid splitting or cracking.
- 5) Ensure wall plugs are well fitted and are a tight fit in the drilled hole.

Types Of Walls

You can use one of the following types of wall plug if your walls are made of brick, breeze block, concrete, stone, wood or plaster board.

**No.1 "Standard" Wall Plug
General Wall Materials**

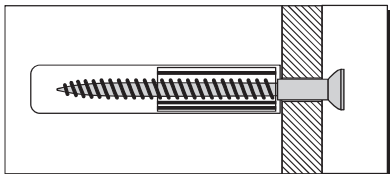

These come in various sizes and are made from plastic or sometimes wood fiber.

**No.2 "General Purpose" Wall Plug
Aerated / Breeze Block**

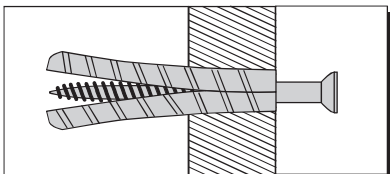

Generally aerated blocks should not be used to support heavy loads, use a specialist fitting in this case. For light loads, a General Purpose Plug can be used.

**No.3 "Shield Anchor" Wall Plug
Heavy Loads**

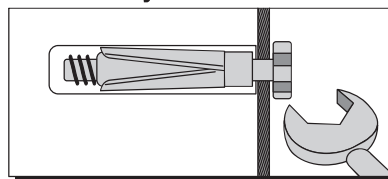

For use with heavier loads such as TV & HiFi Speakers and Satellite Dishes etc.

No.4 "Cavity Fixing" Wall Plug

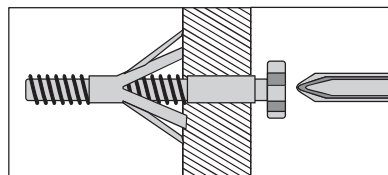

For use with plaster board partitions or hollow wooden doors.

No.5 "Cavity Fixing - Heavy Duty" Wall Plug

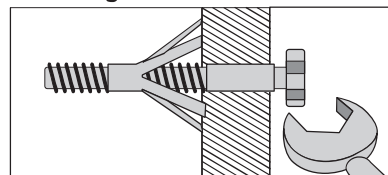

For use when fitting or supporting heavy loads such as shelving, wall cabinets, coat racks.

No.6 "Hammer Fixing" Wall Plug

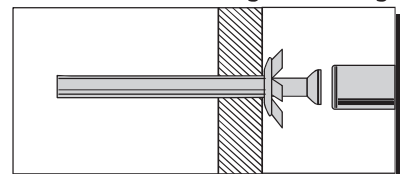

For use with walls stuck with plaster board. The hammer fixing allows it to be fixed to the wall rather than the plaster board. Always check the fixing is secure to the retaining wall.

CARE & MAINTENANCE

 **SAFETY**

Always check the fitting and location to ensure your safety in and around the home.

 **FITTING**

From time to time check the fitting to ensure the wall plugs or screws do not become loose.

If you require any technical guidance or find that your product is not operating as intended, a simple solution can often be found in the **Troubleshooting** section of these instructions

Using your vacuum 4

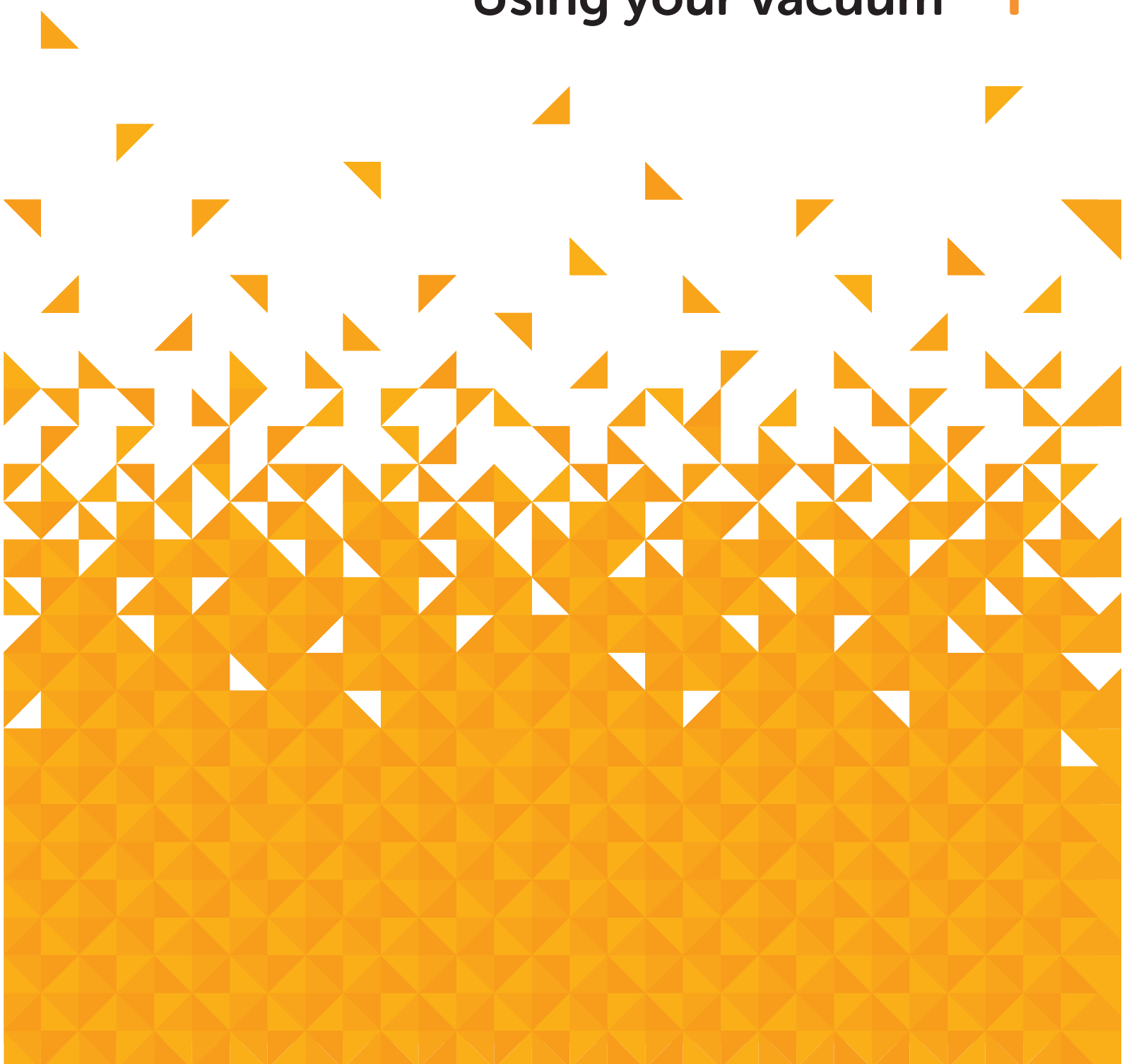

Using your vacuum

Let's get started

Getting started

1. Fit the correct nozzle for the cleaning application, ensure that the battery has sufficient charge.
2. Click power ON/OFF button once to start, the LED lights on the floor head (if fitted) will be illuminated and the vacuum cleaner will start with middle mode (light 1 and 2 is on and light 3 is white), press the "Speed Control Button" once for high speed (light 1 and 2 is on and light 3 is blue), press the "Speed Control Button" again for low speed (light 1 and 2 is on and light 3 is off).
3. Click the power button again to stop the vacuum cleaner after use.
4. Store the vacuum in the wall bracket when not in use.

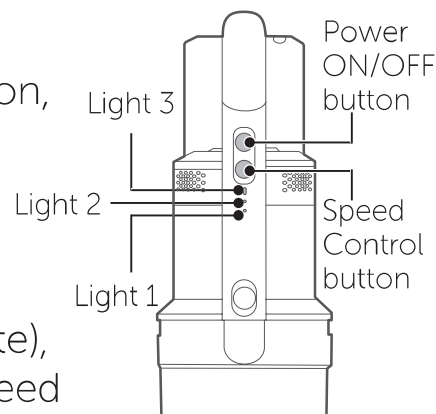

Nozzle use

The table below is for reference only. Use attachments that are suitable to accomplish the job quickly and easily without damaging the cleaning surface.

Nozzle	Cleaning area							
	Floor & carpets	Furniture	Between cushions	Curtains	Stairs	Walls	Skirting edges	Radiators
Floor head	✓				✓			
Combination tool - Upholstery brush		✓		✓	✓	✓		
Combination tool - furniture brush		✓		✓	✓	✓		
Crevice tool		✓	✓		✓		✓	✓

If you require any technical guidance or find that your product is not operating as intended, a simple solution can often be found in the **Troubleshooting** section of these instructions

Care and maintenance 5



Care and maintenance

Looking after your appliance

Maintenance

Disconnect the charger from the vacuum cleaner before carrying out cleaning and maintenance.

To ensure your vacuum cleaner works at optimum efficiency, keep the ventilation holes and vacuum cleaner surface free from dirt.

Ensure that the dust container is emptied and the air filters are washed regularly.

1. Wipe the outside of the vacuum cleaner and accessories with a damp (not wet) cloth and then wipe dry. Do not use detergents, solvents or abrasives as these may scratch or damage the surface.
2. Never immerse the vacuum cleaner, battery or charger in water.
3. When not in use, store in a cool, dry place.

Emptying the dust container

1. When the dust container reaches the MAX line marked on the dust container (fig 11) or when the suction power is reduced, it is time to empty the dust container.
2. Press the lever at the front of the container to open the base (fig. 12) and empty the container. Gently tap the container against the side of the bin to remove any stubborn dust.

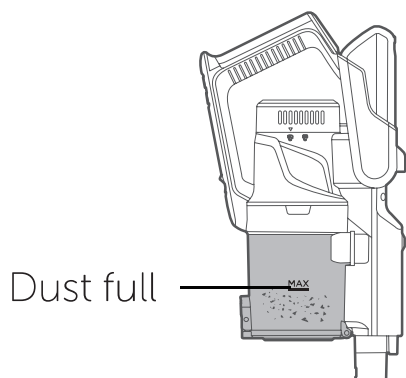

Fig.11

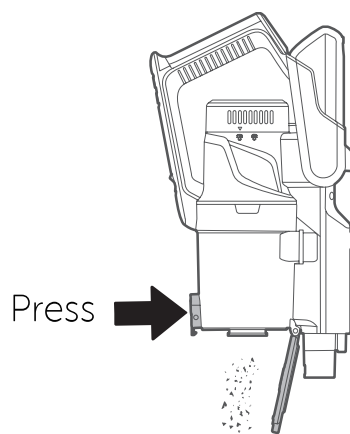

Fig.12

If you require any technical guidance or find that your product is not operating as intended, a simple solution can often be found in the **Troubleshooting** section of these instructions

Care and maintenance

Looking after your appliance

3. The inside of the dust container maybe wiped clean with a damp cloth. Dry with a soft dry cloth before closing the flap. A click will be heard when it is correctly engaged.

Cleaning the filters

1. The frequency that the filters should be cleaned will depend on appliance usage. For maximum efficiency , suggest shake off debris on pre-motor filter and exhaust filter when empty the bin container, rinse under water once a month.
2. Click the dust container release button, located on the front of the handle just above the dust container and pull dust container out(Fig 13)
3. Lift out the cyclone from dust container(Fig 14), lift out pre-motor filter and shake off dust fr equently .Every three months rinse filter and dry thoroughly(Fig 15), turn the filter assembly head clockwise to disassembly the cyclone filter(Fig 16), wash with running water, and make,sure it is dry before next use(Fig 17).

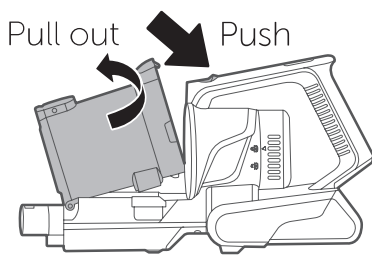

Fig. 13



Fig. 14

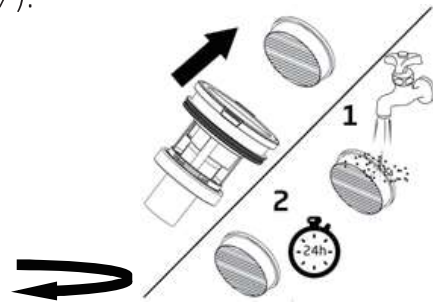

Fig. 15

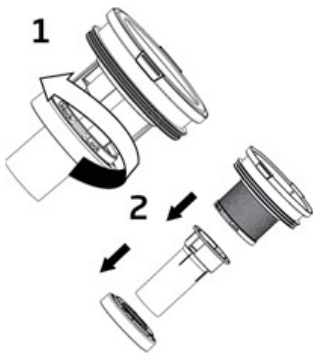

Fig. 16

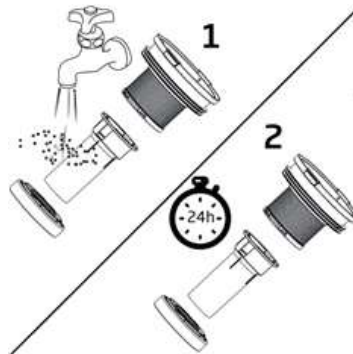

Fig. 17

Care and maintenance

Looking after your appliance

4. Tap the pre-motor filter against a dustbin to remove most of the dust and then wash the filter in cold running water until the water runs clear. Allow to air dry fully. Using a damp or wet filter will reduce the suction and damage the motor.
5. The pre-motor filter can also be washed under running water if needed.
6. When the pre-motor is completely dry, reverse the above steps and refit the filter into the dust container and close the flap. In each case turn in the direction of the locked padlock symbol (fig. 18).
7. To clean or replace the exhaust filter, turn the cover anticlockwise and lift off the cover (fig. 19), remove the filter (fig. 20), shake off debris, rinse under water once a month, allow to dry fully before refit.
8. Refit the exhaust filter and cover onto the cleaner.

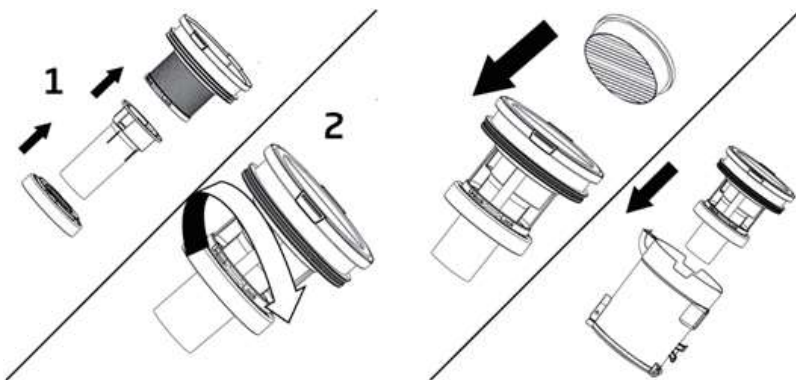

Fig. 18

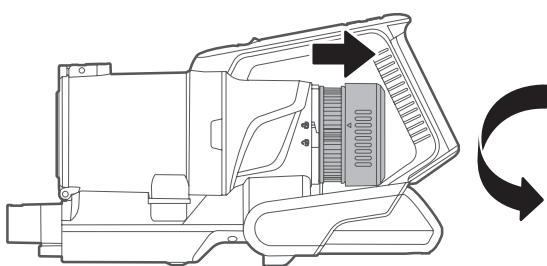

Fig. 19

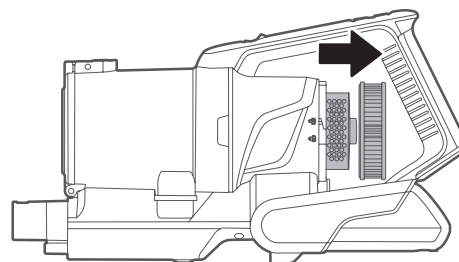

Fig. 20

If you require any technical guidance or find that your product is not operating as intended, a simple solution can often be found in the **Troubleshooting** section of these instructions

Care and maintenance

Looking after your appliance

Cleaning the brush

1. The frequency that the brush should be cleaned will depend on appliance usage. Always stop the vacuum and clean the brush head if the floor head brush stops rotating.
2. Remove the floor head from the cleaner (fig. 19).
3. Push the small lever at the side of the brush in the direction of the front of the floor head and lift off the retaining plate (fig. 20).
4. Lift out the roller brush (fig. 21) and remove any thread, fluff or other obstructions. The brush roller can also be washed under running water if needed. Allow to fully dry.
5. Refit the brush roller and secure into position by fitting the retaining plate.

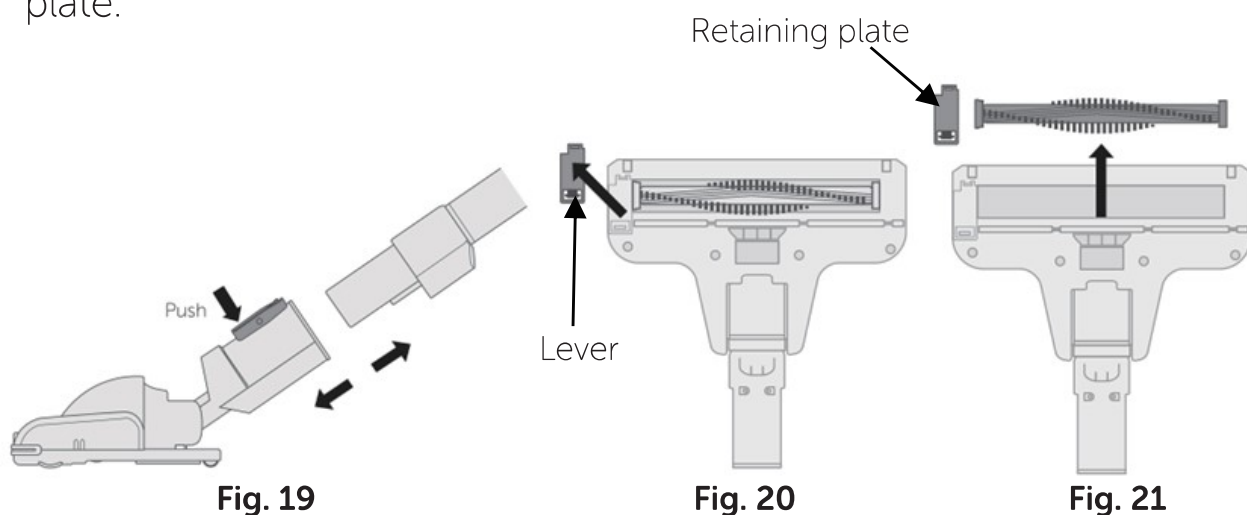

Other information

Technical Specification

Model	V18P01EP29EU
SKU	139443324
Cat No	9481211
Rated voltage (transformer)	100-240V 50-60Hz 0.8A
Transformer output	33.0V \equiv 0.5A 16.5W
Transformer model	MC3805B-B
Class rating (transformer)	II (double insulated)
Rated voltage (vacuum)	28.8V \equiv
Power consumption	350W
Power consumption (standby)	<1W
Running time (approx.)	10 mins with high mode 25 mins with middle mode 50 mins with low mode
Recharge time (from empty)	4-6 Hrs
Noise	80 dB(A)
Capacity	600ml



Recycling electrical products



You should now recycle your waste electrical goods and in doing so help the environment.

This symbol means an electrical product should not be disposed of with normal household waste. Please ensure it is taken to a suitable facility for disposal when finished with.

Visit www.recycle-more.co.uk, click on "bank locator" and enter your postcode to find your nearest recycling site.

If you require any technical guidance or find that your product is not operating as intended, a simple solution can often be found in the **Troubleshooting** section of these instructions

Product support 6



Product support

Help is always at hand

Troubleshooting

Observation	Potential cause / solution
Vacuum cleaner does not work	Does the battery need to be recharged?
	Is the battery fully inserted into the vacuum cleaner
Suction power weak	Does the dust container need to be emptied?
	Is the filter clogged and need to be cleaned?
	Is there something blocking the nozzle or brush?
Dust escaping vacuum cleaner	Check that the dust container is securely attached.
Running time becomes shorter	Ambient temperature too high / low.
	Battery not fully charged
	Battery is aging
Difficulty charging battery	Ambient temperature too high / low.
Battery leaks	The battery has not been used for a long time and needs to be replaced.

3 lights flashing

Are the filters still damp after cleaning?

First use - check if battery pack is connected correctly.

Switch off the machine for 1-2 hours then recharge.

If lights continue to flash contact Bush Customer Helpline

During use - check for airflow restriction or blockage in in the unit, dust container and floor head. Clean filters.

If lights continue to flash contact Bush Customer Helpline

During charging - adapter may need to be replaced.

Contact Bush Customer Helpline

If you require any technical guidance or find that your product is not operating as intended, a simple solution can often be found in the **Troubleshooting** section of these instructions

Product support

Help is always at hand

Help and assistance

If you require any technical guidance or find that your Bush vacuum cleaner is not operating as intended, a simple solution can often be found in the **Troubleshooting** section of these instructions or online at www.bush-support.co.uk

If you still require further assistance, call one of our experts on 0345 604 0105*. To help give us give you a fast and efficient service please have the following information ready:

Model Ref.	<input type="text"/>	You can find this information on the rating plate – a small sticker (usually a sticker or metal plate on the rear of your product)
Serial number	<input type="text"/>	
Date of purchase	<input type="text"/>	This will be shown on your receipt

Local call rates applies*

Lines open 8am-7pm Monday to Saturday and 10am-4pm Sunday.

*Calls to Bush enquiry lines may attract a charge and set up fee from residential lines depending on your call plan / tariff. Mobile and providers costs may vary, see www.bt.com/pricing for details

For security and training purposes, telephone calls to and from customer service centres maybe recorded and monitored. Calls from Republic of Ireland will attract international call charges.

Product support

Help is always at hand

BUSH

Call us now and register your 12 month guarantee

Thank you for choosing Bush. Your new product is guaranteed against faults and breakdowns for 12 months. Don't forget to register it with us today so we can provide you with our best possible after-sales service and useful updates.

www.bushregistration.co.uk

FREEPHONE*

0800 597 8548

Lines are open 8am - 8pm, 365 days a year. *Calls may be recorded and monitored.

Your Bush Guarantee

This product is guaranteed for twelve months from the date of original purchase. Any defect that arises due to faulty materials or workmanship will be repaired free of charge (or if applicable the product will be replaced or the purchase price refunded) where possible during this period by the dealer from whom you purchased the unit.

The guarantee is subject to the following provisions:

- The guarantee does not cover accidental damage, misuse, cabinet parts, knobs or consumable items.
- The product must be correctly installed and operated in accordance with the instructions contained in the manual.
- It must be used solely for domestic purposes. The guarantee will be rendered invalid if the product is re-sold or has been damaged by inexpert repair.
- Specifications are subject to change without notice.
- Bush disclaim any liability for loss or damage arising from the breakdown of the product.
- This guarantee is in addition to and does not diminish your statutory or legal rights.

For your personal Guarantee Confirmation code call **0800 597 8548**
Guarantee Confirmation Code

If you require any technical guidance or find that your product is not operating as intended, a simple solution can often be found in the **Troubleshooting** section of these instructions

Product support

Help is always at hand

Important Data Protection Information

Bush has appointed Domestic & General Insurance PLC to provide product registration services and protection plans to accompany its products.

What we do with your information

At Domestic & General we want to reassure you that we use your information both responsibly and securely to provide you with the best possible service. Below we explain what we do with your information and your rights to your information. If you would like any further details you can get in touch with us using the contact details below or visit our website (www.domesticandgeneral.com).

Using your information

Domestic & General Insurance PLC ("we") is the "data controller" of your information. We process two sets of information about you, "Personal Information" (your name, address, contact and payment details) and the "Goods Information" you provide to register your appliance or device (your name, address, contact and goods details). We'll use your information: (i) as necessary to fulfil our contract with you (including to recover any amounts owing); (ii) for our legitimate interests in: undertaking marketing (about our products and services and those of our third party partners) by post, telephone, email and/or other electronic messaging services; market research; customer surveys; printing services; checking and verifying your identity and contact details; recording your conversations for training, quality and compliance purposes; and for analytics and profiling for marketing purposes; and (iii) where required to do so by law. We may also ask for your consent to some uses of your information.

Sharing your information

From time to time your Personal Information and Goods Information may also be shared with other members of the Domestic & General Group of Companies (Domestic & General Insurance or Services and other future members of the Group whose details we will notify to you ("Group")), with companies acting on our behalf or providing services to us (e.g. the companies we use to carry out repairs, IT & mailing services, storage of paper records and telecommunications) and with the Sainsbury's Argos Group (which currently includes Sainsbury's Supermarkets, Sainsbury's Bank, Argos Limited, Tu Clothing, Habitat, Argos Financial Services, Nectar and Insight 2 Communication, Argos Business Solutions Limited). The Sainsbury's Argos Group will process your Personal Information for their legitimate business interests (including marketing and analytics) in accordance with their privacy policy, which can be found at www.argos.co.uk/help/privacy-policy

Transferring your information

In exceptional cases, we may transfer your information to countries outside the European Economic Area (including the US) which may not have data protection laws which provide the same level of protection as provided in the UK. We have put in place Model Clauses as an appropriate safeguard to ensure that such information is adequately secured and protected and that such transfers meet the requirements of applicable data protection law.

Product support

Help is always at hand

Keeping your information

We keep your Personal Information for six years after you terminate your policy so that we can deal with any claims. Your goods information we keep for a bit longer, normally 10 years (the average life of an appliance) for health and safety. We also keep your information to send you marketing that you might be interested in, unless we receive a request from you to opt-out of marketing.

Rights to your information

By writing to the Data Protection Officer using the contact details provided below, you have the right to ask us:

- for a copy of the Personal Information we hold about you
- for a copy of the Personal Information you provided to us to be sent to you or a third party in a commonly used, machine readable format
- to update or correct your Personal Information to keep it accurate
- to delete your Personal Information from our records if it is no longer needed for the original purpose; and
- to restrict the processing of your Personal Information in certain circumstances

And you may also:

- object to us processing your Personal Information – in which case we will either agree to stop processing or explain why we're unable to; and
- where we rely on your consent, withdraw that consent at any time.

Please note that the above rights are not absolute and certain exemptions apply to them. You can also make a complaint to the Information Commissioner (www.ico.org.uk) if you feel your Personal Information has been mishandled.

Marketing

We, along with other members of our Group, Argos Limited, and other members of the J Sainsbury's Group of Companies may use your information to tell you about any offers, products or services which may be of interest to you. We may contact you by post, telephone, email and/or other electronic messaging services. To change your marketing preference, let us know by emailing marketingpreferences@domesticandgeneral.com or by writing to us using the contact details provided below. If you don't want Argos to send you marketing by phone, email or post then please see Argos's Privacy Policy, which can be found on their website at www.argos.co.uk/help/privacy-policy to opt out of this marketing. Argos will stop sending you marketing communications but will still contact you with service-related messages every now and then.

Contact Details

If you need to contact us about your information or your information rights, or to see a copy of our Model Clauses, please write to: Freepost Plus RTKS-CLRA-GRYE, Data Protection Officer, Domestic & General, Leicester House, 17 Leicester Street, Bedworth, CV12 8JP or dataprotection@domesticandgeneral.com and we'll be happy to help you.

If you require any technical guidance or find that your product is not operating as intended, a simple solution can often be found in the **Troubleshooting** section of these instructions



Or by calling one of our experts on **0345 604 0105**



If you require any technical guidance or find that your product is not operating as intended, a simple solution can often be found in the **Troubleshooting** section of these instructions



Or by calling one of our experts on **0345 604 0105**

BUSH

Should you require any guidance;
call our Help line on 0345 604 0105.
Further contact details can be found online at:
www.bush-support.co.uk

Produced in China for Argos Limited,
London, EC1N 2HT, UK. Argos (N.I.) Ltd, Forestside Shopping Centre,
Upper Galwally, Belfast, BT8 6FX, UK.

Bush is a registered trademark of Argos Ltd.