



Instruction manual

DLED65UHDSFIRE

8914332



Contents

1 Safety information

SOME DO'S AND DON'TS ON THE SAFE USE OF TV	4
Markings on the TV	8

2 Getting to know your TV

Ready? Let's begin...	10
Accessories Included	10
Features	10
Ultra HD (UHD)	10
High Dynamic Range (HDR) / Hybrid Log-Gamma (HLG)	10
Dolby Vision	10
Licences	10
Antenna Connection	11
Turning On/Off the TV	11
Remote Control	12

3 Connections

Other Connections	14-15
Initial Setup Wizard	16

4 Standard features

TV Control & Operation	20
Main Screen	20
Live TV	21
Channel List	21

5 Advanced features

Customising TV Settings	24
To Program Your SKY Remote For Your TV	25
Channel Guide	26
Settings	26
Connecting to the Internet	37

6 Other information

Specification	40
Product Information	40
Stand Installation & Wall Mounting	42
DVB-T functionality information	43
Functionality information	43

7 Product support

Help and assistance	46
Disposal Information	47
Your Bush Guarantee	48
Important Data Protection Information	48

Safety information 1





Safety information

Important - Please read these instructions fully before installing or operating



Don't operate your TV in extreme ambient conditions as this may cause damage to your TV.

Preparation

Place the TV on a solid even surface. For ventilation, leave a free space of at least 10 cm all around the TV. To prevent any fault and unsafe situations, do not place any objects on top of the TV. Use this TV in moderate climates.

Operation temperature and operation humidity: 0°C up to 40° C, 85% rel. humidity max. (not blocking ventilation openings).

Intended Use

This TV is used to receive and display TV programmes. The different connection options make an additional expansion of the reception and display sources possible (various external devices). This TV is only suitable for dry interior use. This TV is intended solely for private domestic use and may not be used for industrial and commercial purposes. We exclude liability in principle, if the TV is not used as intended, or unauthorised modifications have been made. To operate your TV in extreme ambient conditions may cause damage to your TV.

This TV is not intended for use by persons (including children) with reduced physical, sensory or mental capabilities, or lack of experience and knowledge, unless they have been given supervision or instructions concerning use of the TV by a person responsible for their safety. Children should be supervised to ensure that they do not play with the TV.

Children may not recognise dangers. The swallowing of batteries can be fatal. Keep batteries always out of reach of small children. If a battery is swallowed, seek immediate medical attention. Keep the packaging films out of reach of children, there is a risk of suffocation.



The lightning flash with arrowhead symbol, within an equilateral triangle, is intended to alert the user to the presence of uninsulated "dangerous voltage" within the product's enclosure that may be of sufficient magnitude to constitute a risk of electric shock of persons.



The exclamation point within an equilateral triangle is intended to alert the user to the presence of important operating and maintenance (servicing) instructions in the literature accompanying the TV.

Note: Follow the on screen instructions for operating the related features.

Use this TV at an altitude of less than 5000 metres above the sea level, in dry locations and in regions with moderate or tropical climates.

To avoid danger of suffocation, keep plastic bags out of the reach of babies, children and domestic animals.

Carefully attach the stand to the TV. If the stand is provided with screws, tighten the screws firmly to prevent the TV from tilting. Do not over-tighten the screws and mount the stand rubbers properly.

SOME DO'S AND DON'TS ON THE SAFE USE OF TV

Please read the following recommended safety precautions carefully for your safety.

This TV has been designed and manufactured to meet international safety standards but, like any electrical equipment, care must be taken if you are to obtain the best results and safety is to be assured.

DO read the operating instructions before you attempt to use the TV.

DO ensure that all electrical connections (including the mains plug, extension leads and inter-connections between the pieces of TV) are properly made and in accordance with the manufacturer's instructions. Switch off and withdraw the mains plug before making or changing connections.

DO consult your dealer if you are ever in doubt about the installation, operation or safety of your TV.

DO be careful with glass panels or doors on TV.

DO route the power cord so that it is not likely to be walked on, crushed, chafed, or subjected to excessive wear and tear or heat.

DON'T remove any fixed cover as this may expose dangerous voltages.

If you require any technical guidance or find that your TV is not operating as intended, a simple solution can often be found in the **Help Menu**, or online at www.bush-support.co.uk. If you still require further assistance, call one of our experts on **0345 604 0105**, a **Bush enquiry line**.



Safety information

Important - Please read these instructions fully before installing or operating

DON'T obstruct the ventilation openings of the TV with items such as newspapers, tablecloths, curtains, etc. Overheating will cause damage and shorten the life of the TV.

DON'T allow electrical equipment to be exposed to dripping or splashing, or objects filled with liquids, such as vases, to be placed on the TV.

DON'T place hot objects or naked flame sources such as lighted candles or nightlights on, or close to TV. High temperatures can melt plastic and lead to fires.

DON'T use makeshift stands and NEVER fix legs with wood screws - to ensure complete safety always fit the manufacturer's approved stand or legs with the fixings provided according to the instructions.

DON'T listen to headphones at high volume, as such use can permanently damage your hearing.

DON'T leave TV switched on when it is unattended unless it is specifically stated that it is designed for unattended operation or has a standby mode. Switch off using the switch, on the TV and make sure that your family know how to do this. Special arrangements may need to be made for infirm or handicapped people.

DON'T continue to operate the TV if you are in any doubt about it working normally, or if it is damaged in any way - switch off, withdraw the mains plug and consult your dealer.

ABOVE ALL



NEVER let anyone especially children push anything into holes, slots or any other opening in the TV - this could result in a fatal electrical shock.



NEVER guess or take chances with electrical equipment of any kind.



It is better to be safe than sorry!

Power source

• The TV should be operated only from a 220-240 V AC, 50 Hz outlet.

⚠ WARNING: Do not leave your TV in standby or operating mode when you leave your house.

Positioning the TV

• For ventilation, please leave a clear space of at least 10cm all around the TV.

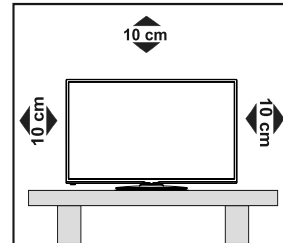

- **Do not** block the ventilation openings.
- **Do not** place the TV on sloping or unstable surfaces, the TV may tip over.
- To prevent damage to the TV, do not place any objects on top of the TV.

Power cord and plug

- Do not place the TV, a piece of furniture, etc. on the power cord (mains lead) or pinch the cord. Handle the power cord by the plug. Do not pull the plug by holding its neck, as this could result in damage to the plug. Do not unplug the TV by pulling from the power cord and never touch the power cord with wet hands as this could cause a short circuit or electric shock. Never make a knot in the cord or tie it with other cords. The power cords should be placed in such a way that they are not likely to be stepped on. A damaged power cord can cause fire or give you an electric shock. When it is damaged and needs to be replaced, it should be done by qualified personnel.
- This TV receiver is supplied with a moulded mains plug. The mains plug must not be cut off, as it may contain a special radio interference filter, the removal of which could lead to impaired performance. If you wish to extend the lead, obtain an appropriate safety approved extension lead or consult your dealer.
- Observe the manufacturers instructions when connecting extension leads to the TV. Check the fuse rating on the new plug; this should be fitted with a 5 Amp fuse which conforms to either ASTA or BSI (BS1362) approvals, these are easily identifiable by either the ⚡ or ⚡ symbols. If you are in any doubt about the installation of an extension lead, please consult a competent electrician.



Safety information

Important - Please read these instructions fully before installing or operating

Moisture and Water

- **Do not** use this TV in a humid or damp place (avoid bathrooms, the sink in the kitchen, and near the washing machine).
- **Do not** expose this TV to rain or water.
- **Do not** place objects filled with liquids, such as flower vases, on top of the TV. Avoid from dripping or splashing.
- If any solid object or liquid falls into the cabinet, unplug the TV and have it checked by qualified personnel before operating it any further.

Ventilation

- The slots and openings on the TV are intended for ventilation and to ensure reliable operation.
- To prevent overheating, these openings must not be blocked or covered in anyway.

Heat sources and Flames

- **Do not** expose the TV to direct sunlight or other heat sources.
- The TV should not be placed near to open flames and sources of intense heat such as an electric heater.
- Ensure that no open flame sources, such as lit candles, are placed on top of the TV.



Headphone Volume

- Excessive sound pressure from earphones and headphones can cause hearing loss, please take care.



Wall Mounting

- To prevent injury, this TV must be securely attached to the wall in accordance with the installation instructions (if the option is available).

LCD Screen

- Occasionally, a few non-active pixels may appear on the screen as a fixed blue, green or red point. Please note that this does not affect the performance of your TV.
- Take care not to scratch the screen with fingernails or other hard objects.

Cleaning

- Before cleaning, unplug the TV from the wall socket.
- **Do not** use liquid or aerosol cleaners. Only use a soft, dry cloth.

Batteries

⚠ WARNING: Incorrect installation of batteries may cause battery leakage and corrosion, resulting in damage to the remote control.

- **Do not** mix old and new batteries, or batteries of different types.

- **Do not** dispose of batteries in a fire.

- **Do not** dispose of batteries with normal household waste, take to a local recycling centre.



⚠ CAUTION: Insert the batteries / rechargeable batteries in the correct polarity. Don't try to recharge non rechargeable batteries and under no circumstances throw them into fire. Danger of explosion. Do not use unequal batteries (old and new, Alkaline and carbon, etc.) simultaneously. If you will not use the TV for a long time, remove the batteries and store the TV in a dry and dust free place. Improper use of batteries may cause an explosion or leakage. If the batteries have leaked, use gloves and clean the remote control thoroughly with a dry cloth! Batteries should not be exposed to heat, such as sunshine, fire or the like.

Replacement Parts

When replacement parts are required, make sure that the service technician has used replacement parts, which are specified by the manufacturer or have the same specifications as the original one. Unauthorised substitutions may result in fire, electrical shock or other hazards.

Taking out of service and storing

Unplug the TV from the mains and pack the TV in an appropriate cardboard box. Remove the batteries from the remote control and pack the remote control with the TV.

✎ NOTE: The TV should be stored in a dry and dust-free room.

Connection to a TV Distribution System from Tuner

TV connected to the protective earthing of the building installation through the mains connection or through other apparatus with a connection to protective earthing and to a TV distribution system using coaxial cable, may in some circumstances create a fire hazard.

Connection to a cable distribution system has therefore to be provided through a device providing electrical isolation below a certain frequency range (galvanic isolator, see BS EN IEC 60728-11).

⚠ CAUTION

Do not put your fingers in the middle between the TV and stand, especially when you carry the TV, as they may be injured.

If you require any technical guidance or find that your TV is not operating as intended, a simple solution can often be found in the **Help Menu**, or online at www.bush-support.co.uk. If you still require further assistance, call one of our experts on **0345 604 0105**, a **Bush enquiry line**.



Safety information

Important - Please read these instructions fully before installing or operating

WARNING

Do not ingest the battery, Chemical Burn Hazard. This TV or the accessories supplied with the TV may contain a coin/button cell battery. If the coin/button cell battery is swallowed, it can cause severe internal burns in just 2 hours and can lead to death. Keep new and used batteries away from children. If the battery compartment does not close securely, stop using the product and keep it away from children. If you think batteries might have been swallowed or placed inside any part of the body, seek immediate medical attention.

WARNING

A TV may fall, causing serious personal injury or death. Many injuries, particularly to children, can be avoided by taking simple precautions such as:

- ALWAYS use cabinets or stands or mounting methods recommended by the manufacturer of the TV.
- ALWAYS use furniture that can safely support the TV.
- ALWAYS ensure the TV is not overhanging the edge of the supporting furniture.
- ALWAYS educate children about the dangers of climbing on furniture to reach TV set or its controls.
- ALWAYS route cords and cables connected to your TV so they cannot be tripped over, pulled or grabbed.
- NEVER place a TV in an unstable location.
- NEVER place the TV on tall furniture (for example, cupboards or bookcases) without anchoring both the furniture and the TV to a suitable support.
- NEVER place the TV on cloth or other materials that may be located between the TV and supporting furniture.
- NEVER place items that might tempt children to climb, such as toys and remote controls, on the top of the TV or furniture on which the TV is placed.
- The TV is only suitable for mounting at heights ≤ 2 m. If the existing TV is going to be retained and relocated, the same considerations as above should be applied.

WALL MOUNTING WARNINGS

- Read the instructions before mounting your TV on the wall.
- The wall mount kit is optional. You can obtain from your local dealer, if not supplied with your TV.
- Do not install the TV on a ceiling or on an inclined wall.
- Use the specified wall mounting screws and other accessories.
- Tighten the wall mounting screws firmly to prevent the TV from falling. Do not over-tighten the screws.

WARNING

Apparatus connected to the protective earthing of the building installation through the MAINS connection or through other apparatus with a connection to protective earthing – and to a TV distribution system using coaxial cable, may in some circumstances create a fire hazard. Connection to a TV distribution system has therefore to be provided through a device providing electrical isolation below a certain frequency range (galvanic isolator).

Symbols in this Instruction Book

The following symbols are used in the Instruction Book as a marker for restrictions and precautions and safety instructions. Note such information for security reasons.

WARNING

If you do not pay attention to such a marked warning, it can cause serious injury or death. Note these warnings strictly, in order to ensure a safe operation.

CAUTION

Such a precaution is marked, you should take up or note, to avoid injury or property damage. Note these instructions strictly, in order to ensure a safe operation.

IMPORTANT

Warnings on the TV and restrictions are displayed like this. Read this information strictly in order to operate the system correctly and avoid damage.

NOTE

Information about the operation and additional explanations are marked like this. To be aware of such information is recommended to ensure that the functions can be used optimally.



Safety information

Important - Please read these instructions fully before installing or operating

Markings on the TV

The following symbols are used **on the TV** as a marker for restrictions and precautions and safety instructions. Each explanation shall be considered where the TV bears related marking only. Note such information for security reasons.



Class II Equipment: This TV is designed in such a way that it does not require a safety connection to electrical earth.



Hazardous Live Terminal: The marked terminal(s) is/are hazardous live under normal operating conditions.



Caution, See Operating Instructions: The marked area(s) contain(s) user replaceable coin or button cell batteries.



Class 1 Laser Product: This TV contains Class 1 laser source that is safe under reasonably foreseeable conditions of operation.

Hereby, Argos declares that the radio equipment type TFT IDTV is in compliance with Directive 2014/53/EU and Radio Equipment Regulations 2017. The full text of the declaration of conformity is available at the Following internet address: <https://www.argos-support.co.uk/>

The illustrations and the OSD in this instruction manual are for explanation purposes and may vary slightly from the actual operations. TV design and specifications may be changed without notice.

If you require any technical guidance or find that your TV is not operating as intended, a simple solution can often be found in the **Help Menu**, or online at www.bush-support.co.uk. If you still require further assistance, call one of our experts on **0345 604 0105**, a **Bush enquiry line**.

Getting to know your TV 2

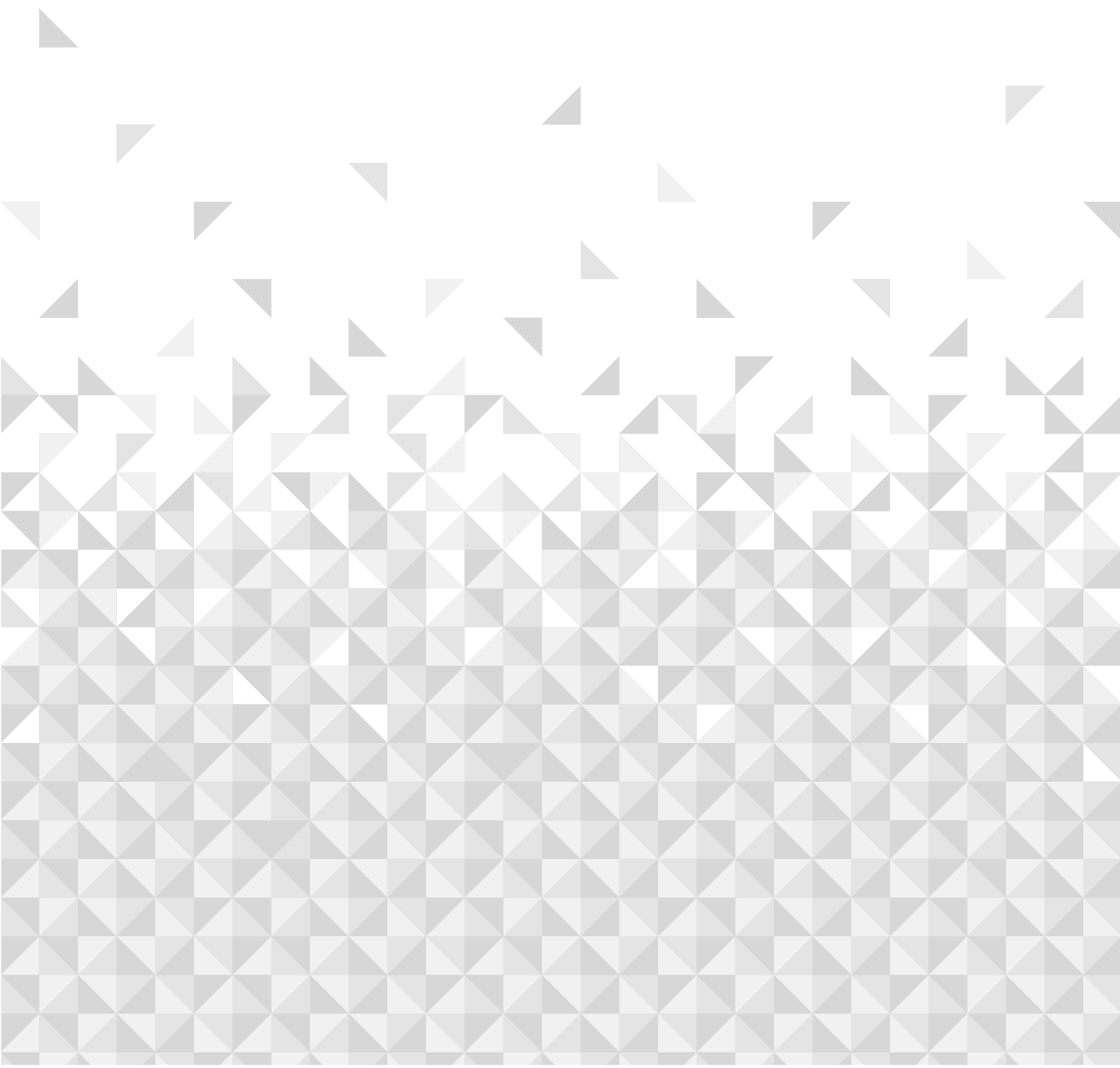

Getting to know your TV

You'll be up and running in no time

Ready? Let's begin...

Please read these instructions carefully. They contain important information which will help you get the best from your TV and ensure safe and correct installation and operation.

If you require any further assistance, our technical experts are happy to help. For full details, refer to the product support section at the end of these instructions.

Accessories Included

- Remote Control
- Batteries: 2 x AAA
- Instruction Manual
- Quick Start Guide

Features

Ultra HD (UHD)

TV supports Ultra HD (Ultra High Definition - also known as 4K) which provides resolution of 3840 x 2160 (4K:2K). It equals 4 times the resolution of Full HD TV by doubling the pixel count of the Full HD TV both horizontally and vertically. Ultra HD content is supported from HDMI, some of the Over-the-Top (OTT) services and USB inputs.

High Dynamic Range (HDR) / Hybrid Log-Gamma (HLG)

Using this feature the TV can reproduce greater dynamic range of luminosity by capturing and then combining several different exposures. HDR/HLG promises better picture quality thanks to brighter, more realistic highlights, more realistic colour and other improvements. It delivers the look that filmmakers intended to achieve, showing the hidden areas of dark shadows and sunlight with full clarity, colour and detail. HDR/HLG content is supported via native and market applications, HDMI and USB inputs. When the input source is set to the related HDMI input, highlight the related HDMI option in the **Home > Settings > Display & Audio > Picture Settings** menu and press **Select** to display setting options. Set the **HDMI Input Mode** option in the **Advanced Settings** menu as **Mode 2 (2.0) or Auto** in order to watch HDR/HLG content, if the HDR/HLG content is received through an HDMI input. The source device should also be at least HDMI 2.0a compatible in this case.

Dolby Vision

Dolby Vision™ delivers a dramatic visual experience, astonishing brightness, exceptional contrast, and vivid colour, that brings entertainment to life. It achieves this stunning image quality by combining HDR and wide colour gamut imaging technologies. By increasing the brightness of the original signal and using a higher dynamic colour and contrast range, Dolby Vision presents amazing true-to-life images with stunning detail that other post-processing technologies in the TV aren't able to produce. Dolby Vision is supported via native and market applications, HDMI and USB inputs. When the input source is set to the related HDMI input, highlight the related HDMI option in the **Home > Settings > Display & Audio > Picture Settings** menu and press **Select** to display setting options. Set the **HDMI Input Mode** option in the **Advanced Settings** menu as **Mode 2 (2.0) or Auto** in order to watch Dolby Vision content, if the Dolby Vision content is received through an HDMI input. The source device should also be at least HDMI 2.0a compatible in this case. In the **Picture Mode** menu two predefined picture modes will be available if Dolby Vision content is detected: **Dolby Vision Bright** and **Dolby Vision Dark**. Both allow the user to experience the content in the way the creator originally intended with different ambient lighting conditions. To change the **Picture Mode** setting press and hold the **Home** button while watching the Dolby Vision content and go to **Picture** menu. While watching Dolby Vision content via an application, except YouTube, Netflix and Multi Media Player, you will not be able to access the **Picture** menu and set the **Picture Mode**.

Features and specifications are subject to change without prior notice.

Licences

The terms HDMI, HDMI High-Definition Multimedia Interface, and the HDMI Logo are trademarks or registered trademarks of HDMI Licensing Administrator, Inc.



Dolby, Dolby Vision, Dolby Audio, and the double-D symbol are trademarks of Dolby Laboratories Licensing Corporation. Manufactured under licence from Dolby Laboratories. Confidential unpublished works. Copyright © 1992-2021 Dolby Laboratories. All rights reserved.



If you require any technical guidance or find that your TV is not operating as intended, a simple solution can often be found in the **Help Menu**, or online at www.bush-support.co.uk. If you still require further assistance, call one of our experts on **0345 604 0105**, a **Bush enquiry line**.

Getting to know your TV

You'll be up and running in no time

For DTS patents, see <http://patents.dts.com>. Manufactured under licence from DTS Licensing Limited. DTS, the Symbol, DTS and the Symbol together, DTS-HD, and the DTS-HD logo are registered trademarks or trademarks of DTS, Inc. in the United States and/or other countries. © DTS, Inc. All Rights Reserved.



For DTS patents, see <http://patents.dts.com>. Manufactured under licence from DTS Licensing Limited. DTS, the Symbol, DTS and the Symbol together, Virtual:X, and the DTS Virtual:X logo are registered trademarks or trademarks of DTS, Inc. in the United States and/or other countries. © DTS, Inc. All Rights Reserved.



This product contains technology subject to certain intellectual property rights of Microsoft. Use or distribution of this technology outside of this product is prohibited without the appropriate licence(s) from Microsoft.

Content owners use Microsoft PlayReady™ content access technology to protect their intellectual property, including copyrighted content. This device uses PlayReady technology to access PlayReady-protected content and/or WMDRM-protected content. If the device fails to properly enforce restrictions on content usage, content owners may require Microsoft to revoke the device's ability to consume PlayReady-protected content. Revocation should not affect unprotected content or content protected by other content access technologies. Content owners may require you to upgrade PlayReady to access their content. If you decline an upgrade, you will not be able to access content that requires the upgrade.

The "CI Plus" Logo is a trademark of CI Plus LLP.

This product is protected by certain intellectual property rights of Microsoft Corporation. Use or distribution of such technology outside of this product is prohibited without a licence from Microsoft or an authorised Microsoft subsidiary.

The Bluetooth® word mark and logos are registered trademarks owned by the Bluetooth SIG, Inc. and any use of such marks by Vestel Elektronik Sanayi ve Ticaret A.S. is under licence. Other trademarks and trade names are those of their respective owners.

Amazon, Alexa, Fire, Prime Video and all related logos are trademarks of Amazon.com, Inc. or its affiliates.

Antenna Connection

Connect the aerial plug to the AERIAL INPUT (ANT) socket located on the rear side of the TV.

Rear side of the TV

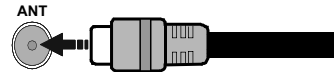

If you want to connect a device to the TV, make sure that both the TV and the device are turned off before making any connection. After the connection is done, you can turn on the units and use them.

Turning On/Off the TV

Connect power

IMPORTANT: The TV is designed to operate on 220-240V AC, 50 Hz socket.

After unpacking, allow the TV to reach the ambient room temperature before you connect the TV to the mains.

Plug the power cord to the mains socket outlet. The TV will switch to standby mode.

To switch on the TV from standby

If the TV is in standby mode the standby LED lights up. To switch on the TV from standby mode either:

- Press the **Standby** button on the remote control.
- Press the control button on the TV.

The TV will then switch on.

To switch the TV into standby

- Press the **Standby** button on the remote control.
- Press the control button on the TV, the function options menu will be displayed. The focus will be on the **Inputs** option. Press the button consecutively until the **Power Off** option is highlighted. Press and hold the button for about 2 seconds, the TV will switch into standby mode.

To switch off the TV

To power down the TV completely, unplug the power cord from the mains socket.

If you require any technical guidance or find that your TV is not operating as intended, a simple solution can often be found in the **Help Menu**, or online at www.bush-support.co.uk. If you still require further assistance, call one of our experts on **0345 604 0105**, a **Bush enquiry line**.

Getting to know your TV

You'll be up and running in no time

Remote Control

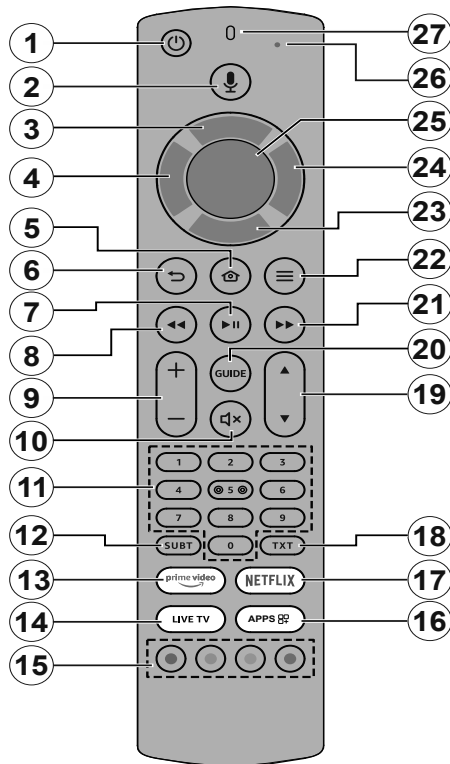

Inserting the Batteries into the Remote

Remove the back cover to reveal the battery compartment on the back side of the remote control first. Insert two 1.5V - size **AAA** batteries. Make sure the (+) and (-) signs match (observe correct polarity). Do not mix old and new batteries. Replace only with same or equivalent type. Place the cover back on.

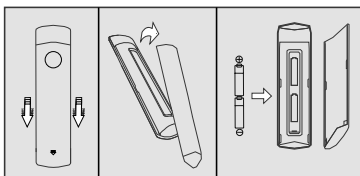

To pair remote with the TV

When TV is turned on for the first time, a pairing process for your remote will be performed during the initial setup. Your remote control should automatically pair with your TV at this point, but if it didn't, follow the on screen instructions to pair it. If you experience difficulties pairing your remote with your TV you can turn off other wireless devices and try again.

If you require any technical guidance or find that your TV is not operating as intended, a simple solution can often be found in the **Help Menu**, or online at www.bush-support.co.uk. If you still require further assistance, call one of our experts on **0345 604 0105**, a **Bush enquiry line**.

1. **Standby:** Standby / On
 2. **Alexa Voice Button:** Activates the microphone on the remote
 3. **Up Directional button (*)**
 4. **Left Directional button (*)**
 5. **Home:** Opens the Home screen. Press and hold or press twice to display quick settings menu
 6. **Back/Return:** Returns to previous menu screen, goes one step back, closes open windows, closes teletext (in Live TV-Teletext mode), returns to main screen or **Home** tab
 7. **Play/Pause**
Pause: Pauses the media being played
Play: Starts to play selected media
 8. **Rewind:** Moves frames backwards in media such as movies, scrolls back a day in the channel guide
 9. **Volume +/-:** Increases/decreases the volume level
 10. **Mute:** Completely turns off the volume of the TV
 11. **Numeric buttons:** Switches the channel in Live TV mode, enters a number or a letter in the text box on the screen
 12. **Subtitle:** Displays audio and subtitle options, where you can change the language, size and style preference (where available)
 13. **Prime Video:** Opens Prime Video screen
 14. **Live TV:** Switches to Live TV mode to watch TV channels
 15. **Coloured Buttons:** Follow the on-screen instructions for coloured button functions
 16. **Apps:** Displays your apps & games
 17. **Netflix:** Launches the Netflix application
 18. **Text:** Opens and closes teletext or interactive services (where available in Live TV mode)
 19. **Programme +/-:** Increases/Decreases channel number in Live TV mode
 20. **Guide:** Displays the channel guide
 21. **Fast forward:** Moves frames forward in media such as movies, scrolls forward a day in the channel guide
 22. **Options:** Displays setting options (where available)
 23. **Down Directional button (*)**
 24. **Right Directional button (*)**
 25. **Select:** Confirms selections, enters sub-menus
 26. **Alexa LED:** Illuminates when the Alexa Voice Button is pressed and during pairing process
 27. **Microphone opening:** Speak into the microphone when using Alexa or voice search.
- (*) **Directional buttons:** Navigates menus, setting options, moves the focus or cursor, etc. Follow the on-screen instructions.

Connections 3

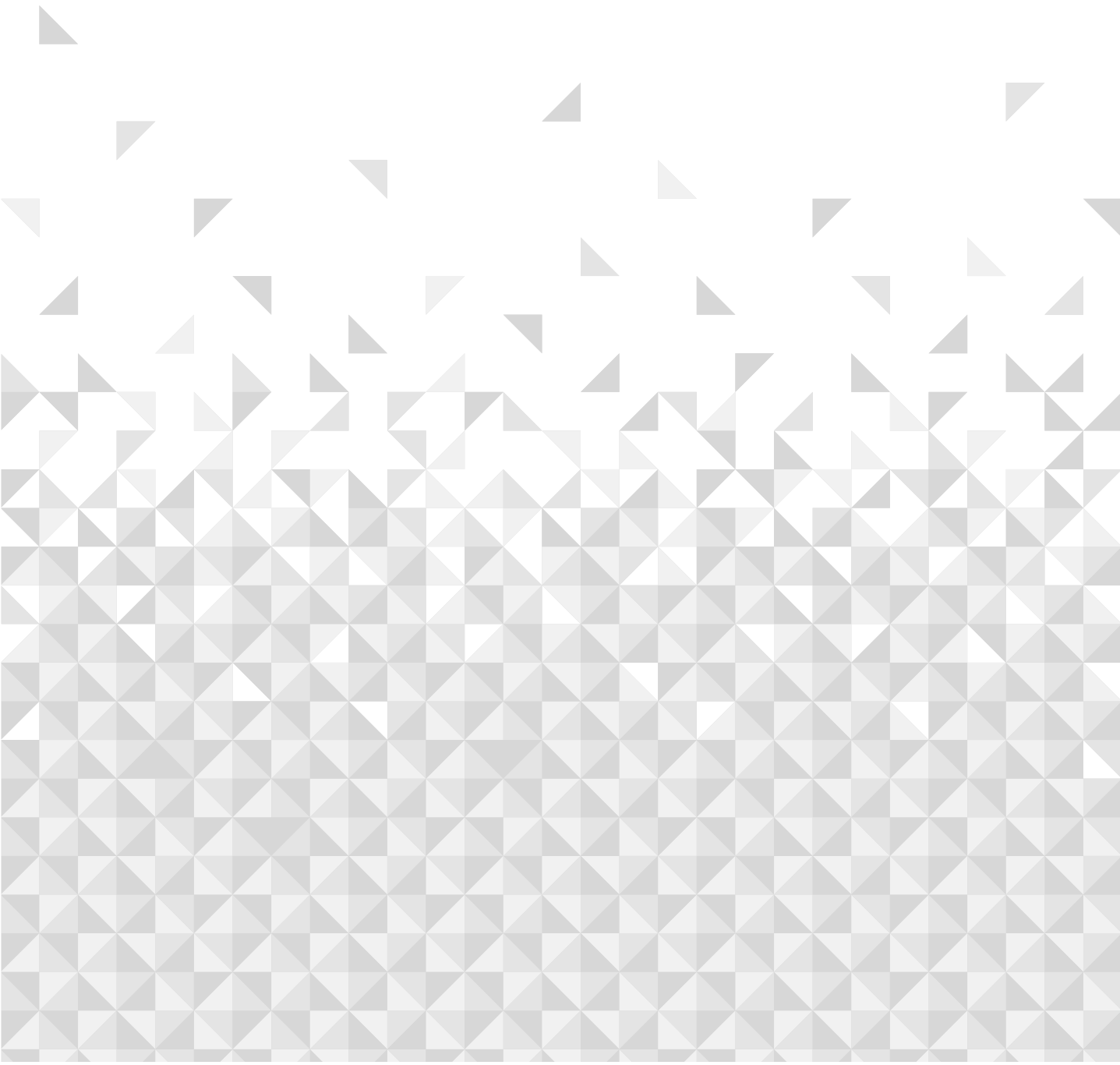

Connections

Bringing it all together

Other Connections

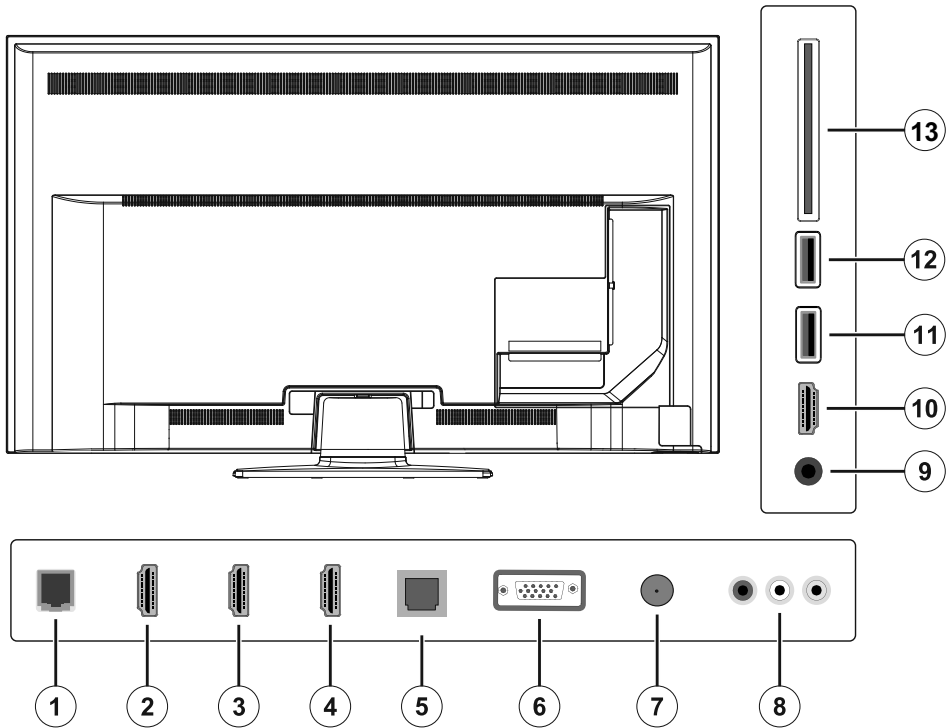

- | | | |
|----------------------------|---|-------------------------|
| 1. Ethernet Connection | 5. SPDIF - Optical Out Connection | 9. Headphone Connection |
| 2. HDMI 2 (ARC) Connection | 6. VGA Connection | 10. HDMI 1 Connection |
| 3. HDMI 3 Connection | 7. Antenna Connection | 11. USB Connection 1 |
| 4. HDMI 4 Connection | 8. VGA Audio / Composite (Audio/Video) Connection | 12. USB Connection 2 |
| | | 13. CI Connection |











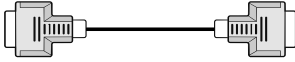
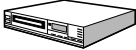









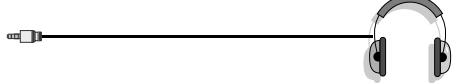

If you require any technical guidance or find that your TV is not operating as intended, a simple solution can often be found in the **Help Menu**, or online at www.bush-support.co.uk. If you still require further assistance, call one of our experts on **0345 604 0105**, a **Bush enquiry line**.

Connections

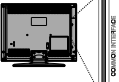
Bringing it all together

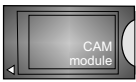
Other Connections

 If you want to connect a device to the TV, make sure that both the TV and the device are turned off before making any connection. After the connection is done, you can turn on the units and use them.

Connector	Type	Cables	Device
	HDMI Connection (back&side)		
	VGA Connection (back)		
	VGA Audio Connection (back)	 VGA Audio Cable	
	SPDIF (Optical Out) Connection (back)		
	Composite (Audio/Video) Connection (back)	 Audio Video Cable	
	Headphone Connection (side)		
	USB Connection (side)		
	CI Connection (side)		
	Ethernet Connection (back)	 LAN / Ethernet Cable	

To enable VGA audio, you will need to use the back audio inputs with a VGA audio cable for audio connection. When using the wall mounting kit (contact your dealer to purchase one, if not supplied), we recommend that you plug all your cables into the back of the TV before mounting on the wall. Insert or remove the CI module only when the TV is SWITCHED OFF. You should refer to the module instruction manual for details of the settings. The USB inputs on the TV support devices up to 500mA. Connecting devices that have current value above 500mA may damage your TV. When connecting equipment using a HDMI cable to your TV, to guarantee sufficient immunity against parasitic frequency radiation and trouble-free transmission of high definition signals, such as 4K content, you have to use a high speed shielded (high grade) HDMI cable with ferrites.

If you require any technical guidance or find that your TV is not operating as intended, a simple solution can often be found in the **Help Menu**, or online at www.bush-support.co.uk. If you still require further assistance, call one of our experts on **0345 604 0105**, a **Bush enquiry line**.

Connections

Bringing it all together

Initial Setup Wizard

Note: Follow the on-screen instructions to complete the initial setup process. Use the directional buttons and the **Select** button on the remote to select, set, confirm and proceed.

1. Choose Your Language

The language selection options will be listed on the screen. Select the desired language from the list and press **Select** to continue.

2. Select TV Mode

In the following step of the initial setup, you can set the TV's operation mode. **Store Use** option will configure your TV's settings for store environment. This option is intended only for store use. It is recommended to select **Continue** for home use.

3. Pair Your Remote with your TV

If your remote does pair with your TV automatically or if you have paired your remote with your TV once previously, this step will be skipped. If this is not the case, a search for your remote will be performed. Follow the on-screen instructions to pair your remote control (depends on the model of the remote control).

4. Connect to your network

Even if you did connect your TV to internet via an Ethernet cable before the initial setup begins the network connection will not be available automatically, you first have to enable it in this step. A confirmation dialogue will be displayed on the screen. You will be informed that the power consumption may increase and be asked for your consent to continue. Highlight **Enable** and press **Select** to proceed.

If you didn't connect your TV to internet via an Ethernet cable, your TV will search and list available wireless networks at this point after you enable network connection. Select your network and press **Select** to connect to it.

You can review or change the network settings later using the options in the **Settings > Network** menu. Refer to the **Network** and **Connecting to the Internet** sections if you need further information. Press **Fast Forward** button on your remote to skip.

After the internet connection is established, the TV will check for software updates and download the latest software next, if any available. Please notice that this will take some time.

5. Sign In with Your Amazon Account

You can sign in to your Amazon account on the next screen. You need to be signed in to an Amazon account in order to use Amazon services. This step will be skipped if no internet connection has been established in the previous step. If you don't already have an Amazon account you can set up an account by choosing 'I am new to Amazon' option. You can press the **Fast Forward** button to skip this step. A dialogue will be displayed for confirmation. Highlight **Do this later** and press **Select** to continue. If you skip this step some of the following steps may differ or be skipped as well.

Once the account has been registered, you will be asked whether you want to use the account you signed in. You can choose to change the account, read the terms and conditions, which will be accepted if you continue, at this point. Highlight the symbol with three dots next to the texts at the bottom side of the screen and press **Select** to read and learn more about the related subject. Highlight **Continue** and press **Select** button to proceed without changing the account.

If you have connected your TV to internet via a WLAN network a dialogue will be displayed at this point, asking if you want to save your WLAN password to Amazon. Highlight **Yes** and press **Select** to confirm and proceed. Select **No** to proceed without confirmation.

6. Parental Controls

You can enable Parental Controls at this point or you can do it later.

Note that, if you choose **No Parental Controls**, purchasing and video playback without PIN will be allowed.

If you choose **Enable Parental Controls** option, you will be asked to enter a PIN next. This is the Prime Video PIN and it is related to your Amazon account. Use the buttons on your remote as shown on the screen to enter the PIN. You will have to enter it to access some menus, services, content, etc. protected by this PIN. If you have forgotten your PIN follow the link shown on the screen to reset your PIN.

You will be informed about the feature on the next screen. Press **Select** to continue.

You can review or change the parental control settings later using the **Parental Controls** option in the **Settings > Preferences** menu.

7. Prime Video

A brief information on the prime video services will be displayed next. You can start your 30 day free trial at this point. Highlight 'No Thanks' and press **Select** to skip.

If you require any technical guidance or find that your TV is not operating as intended, a simple solution can often be found in the **Help Menu**, or online at www.bush-support.co.uk. If you still require further assistance, call one of our experts on **0345 604 0105**, a **Bush enquiry line**.

Connections

Bringing it all together

8. Select Apps

In the next step you can select the apps you want to download. Highlight **Choose Apps** and press **Select** to proceed. The apps are free to download but some of them may require payment for full access. Highlight **No Thanks** and press **Select** to skip.

9. Scan for TV channels

You will be asked whether you want to scan for channels in the next step. Highlight **Yes** and press **Select** button to start the scan process. Highlight **No** and press **Select** button to scan later.

Before the scan starts, you will be asked to check if your aerial is set up and your antenna cable is plugged properly into the antenna socket on your TV. Press **Select** to proceed.

10. Country

In the next step select your **Country** from the list and press **Select** to continue.

11. Transmission Method

The next step is the selection of the transmission method. Select your scanning preference to install channels for Live TV function. **TV** options will be available.

After selecting an option, the TV will search for digital terrestrial broadcasts. Select the searching method and press **Select** to start search.

While the search continues you can press the **Select** button to cancel. A dialogue will be displayed for confirmation. Highlight **Yes** and press **Select** to cancel.

When the initial setup is completed the results will be displayed. You can choose to make changes on the channel list or rescan at this point. Highlight **Done** and press **Select** to finish the setup.

Home screen will be displayed. In order to switch to Live TV mode and watch TV channels highlight a channel from the **On Now** row on the **Home** screen or from the **On Now** row on the **Live** screen and press **Select** to start watching. These rows will not be available if no channels are installed.

Standard features 4

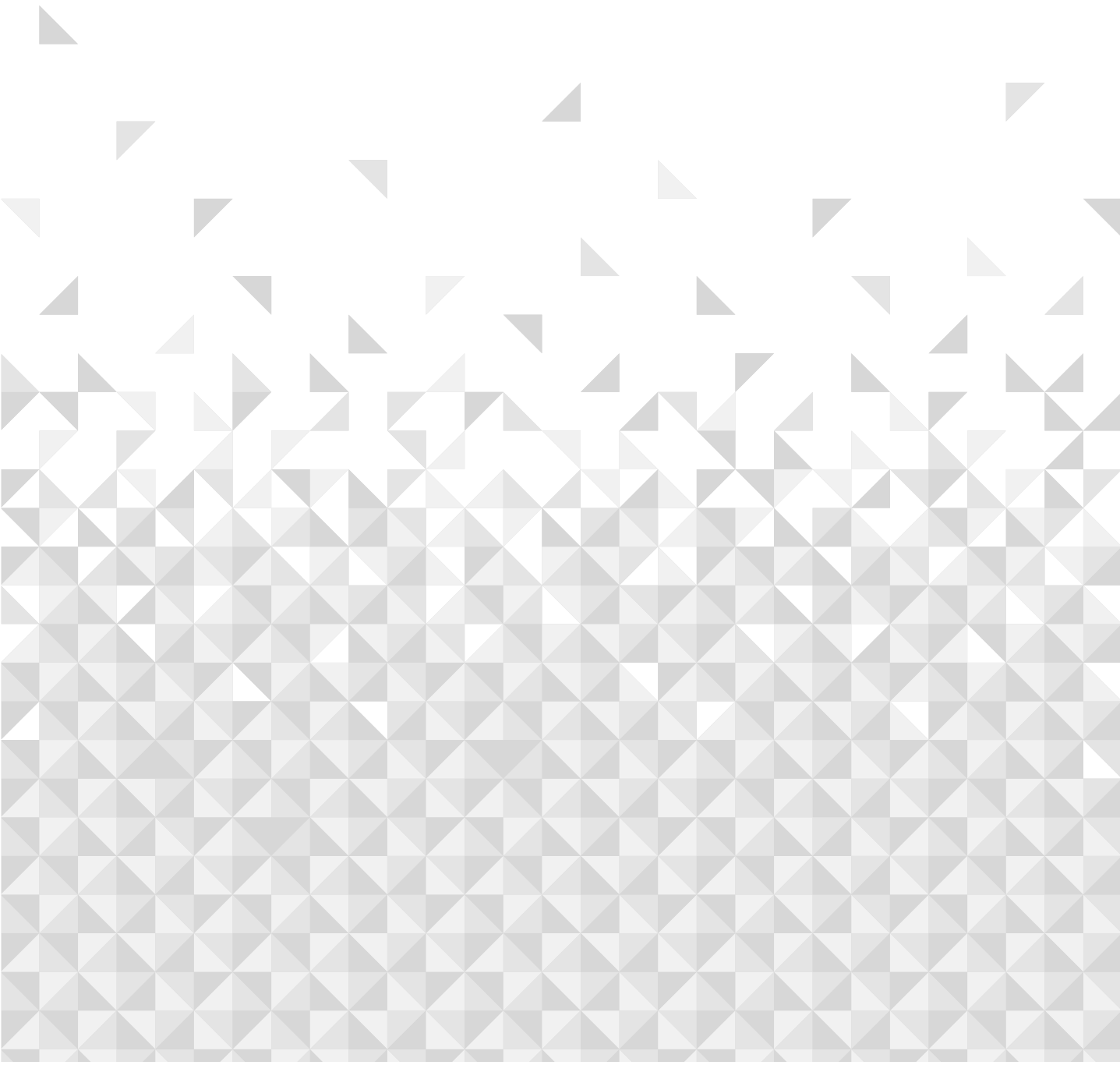

Standard features

Simple everyday use

TV Control & Operation

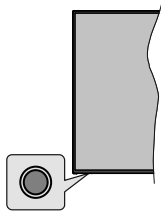

Your TV has a single control button. This button allows you to control the Inputs / Volume Up-Down / Channel Up-Down / Standby-On functions of the TV.

Note: The position of the control button may differ depending on the model.

Operating with the Control Button

- Press the control button to display the function options menu.
- Then press the button consecutively to move the focus to the desired option if needed.
- Press and hold the button for about 2 seconds to use the function, enter the sub menu or select the option.

To turn the TV off: Press the control button to display the function options menu, the focus will be on the **Inputs** option. Press the button consecutively until the **Power Off** option is highlighted. Press and hold the button for about 2 seconds to turn the TV off (standby mode).

To turn on the TV: Press the control button, the TV will turn on.

To change volume: Press the control button to display the function options menu and then press the button consecutively to move the focus to **Volume Up** or **Volume Down** option. Press and hold the button to increase or decrease the volume.

To change channel (in Live TV mode): Press the control button to display the function options menu and then press the button consecutively to move the focus to **Channel Up** or **Channel Down** option. Press and hold the button to switch to the next or previous channel in the channel list.

To change input: Press the control button to display the function options menu, the focus will be on the **Inputs** option. Press and hold the button for about 2 seconds to display the inputs list. Scroll through the available input options by pressing the button. Press and hold the button for about 2 seconds to switch to the highlighted input option.

Note: Live TV settings menu OSD in Live TV mode cannot be displayed via the control button.

Operation with the Remote Control

Press and hold the **Home** button on your remote control to display available quick settings menu options when in Live TV mode. Press **Home** button to display or return to the Home screen of your Fire TV. Use the directional buttons to move the focus, proceed, adjust some settings and press **Select** to make selections in order to make changes, set your preferences, enter a sub-menu, launch an application, etc. Press **Back/Return** to return to the previous menu screen.

Input Selection

Once you have connected external systems to your TV, you can switch to different input sources. Press and hold the **Home** button on your remote control to display available quick settings menu options. Then highlight the **Inputs** option and press the **Select** button to display the list of available input options. Use the directional buttons to highlight the option of your choice and then press the **Select** button to switch to the selected input. Or select the desired input from the **Inputs** row on the Home screen and press **Select**.

Changing Channels and Volume

You can adjust the volume by using the **Volume +/-** buttons and change the channel in Live TV mode by using the **Programme +/-** buttons on the remote.

Main Screen

To enjoy the benefits of your Amazon Fire TV, your TV must be connected to the Internet. Connect the TV to a home network with a high-speed Internet connection. You can connect your TV wirelessly or wired to your modem/router. Refer to the **Network** and **Connecting to the Internet** sections for further information on how to connect your TV to the internet.

The main screen is the centre of your TV. Press the **Home** button on your remote to display the main screen. From the main screen you can start any application, switch to a TV channel, watch a movie or switch to a connected device, manage the settings. Depending on your TV setup and your country selection in the initial setup the main screen may contain different items.

The main screen is organised into several tabs: **Profiles, Inputs, Home, Find, Live, App Peeks, Your Apps** and **Settings**. You can scroll through them using the directional buttons. Available tabs may differ depending on the network connection status of your TV and whether you signed in to your Amazon account. Move the focus to the desired tab option to display the content. Available options of the highlighted tab will be positioned in rows generally. To navigate through the options use

If you require any technical guidance or find that your TV is not operating as intended, a simple solution can often be found in the **Help Menu**, or online at www.bush-support.co.uk. If you still require further assistance, call one of our experts on **0345 604 0105**, a **Bush enquiry line**.

Standard features

Simple everyday use

the directional buttons on the remote. Select a row then move the focus to the desired item in the row. Press **Select** button to make a selection or to enter a sub-menu.

Find is where you can search and find the content that you'll looking for. It has a dedicated search function where you can either press the **Alexa** Voice Button and ask Alexa to find what you're looking for or you can type a search. Library will show any content that you have added to your Watchlist.

Live TV

Live TV refers to channels that have been tuned in via an aerial connection. There are several ways to watch Live TV channels. You can press the **Live TV** button on the remote to switch to Live TV mode and watch TV channels. You can also highlight the **Aerial** option from the **Inputs** row on the **Home** screen and press **Select** or highlight a channel from the **Recent** or **On Now** row on the **Home** screen and press **Select** to start watching.

If the channel installation is not completed **On Now** row will not be available and **Live TV** menu will be displayed when the **Live TV** button is pressed or **Aerial** input option is selected.

Channel List

The TV stores and shows all channels in the channel list. Press the **Live TV** button then the **Down directional** button to see the channel list in Live TV mode. You can press the **Left** and **Right directional** buttons to scroll through the list.

Use the **directional** buttons and the **Select** button to navigate the channel list, change channel and view additional information on programmes.

Press the **Down directional button** twice when the channel list first appears to see the options menu. You can set the subtitle and audio preferences and access the channel guide using the related options of this menu.

Refer to **Channel Guide** section for information on managing channels.

Advanced features 5

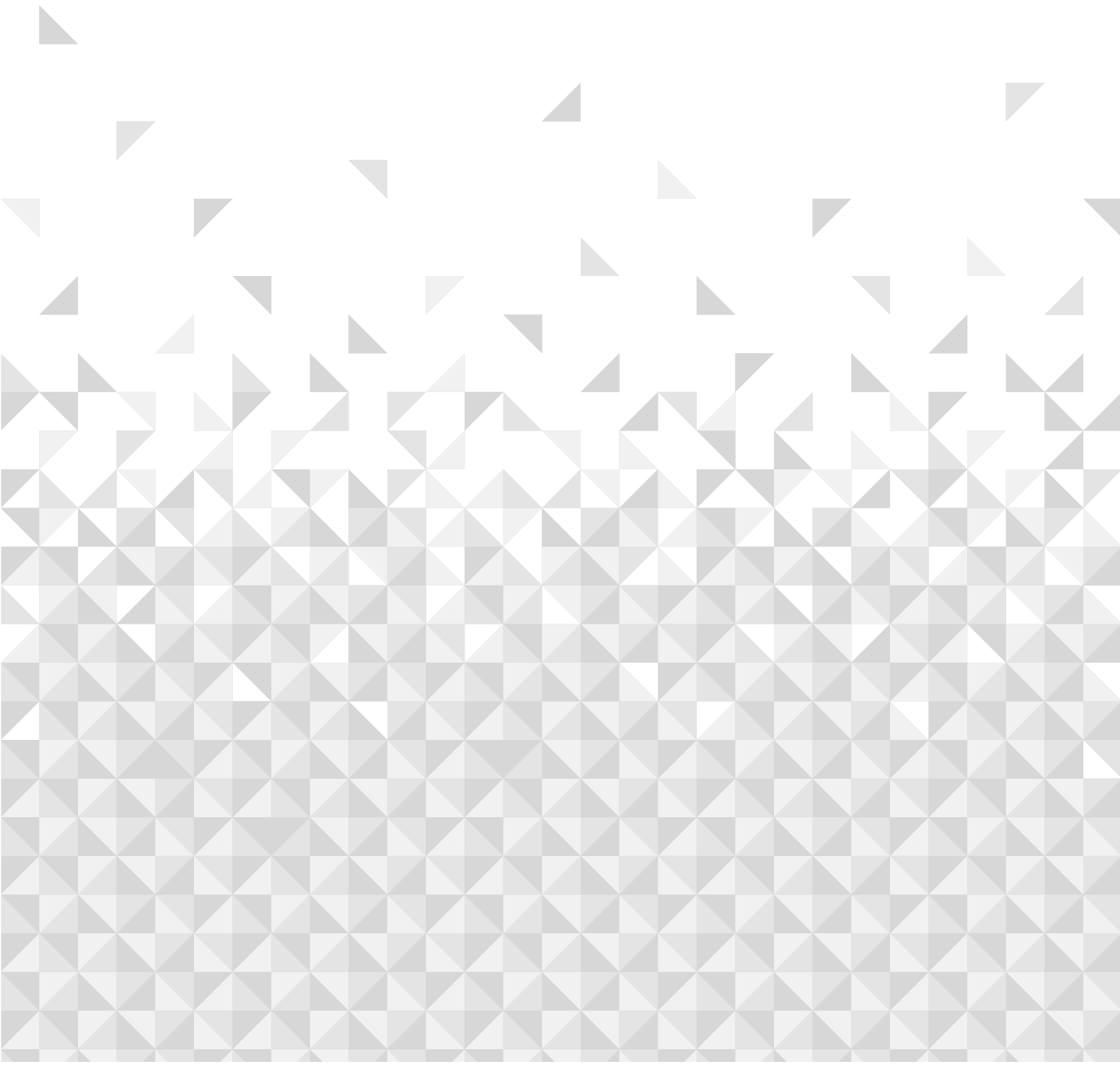

Advanced features

Getting the most from your TV

Customising TV Settings

Adjusting the Picture Settings

Allows you to set your preferred picture settings. You can access the picture settings menu via the **Settings** menu on the main screen or by pressing and holding the **Home** button for about 2 seconds while viewing any input.

Accessing Picture Settings via Settings Menu

Press the **Home** button, scroll to **Settings** tab and press the **Select** button. Scroll to **Display & Audio** option and press the **Select** button. Scroll down to **Picture Settings** option and press the **Select** button. Scroll down to select the input that you want to adjust the picture setting of and press **Select** button. The TV will now change to the selected input. The **Picture Settings** menu will appear on the right hand side of the screen.

Accessing Picture Settings while watching the TV

While watching the input that you would like to adjust press and hold the **Home** button for 2 seconds. The quick settings menu will appear on the right hand side of the screen. Scroll down and highlight **Picture** then press **Select**. The picture setting options will appear on the right hand side of the screen.

Picture Menu Content

The following options show all the available picture setting adjustment on your TV.

Picture settings are input-specific and all of these settings will not apply to all Inputs. Some options may not be available depending on the input source.

Picture Mode: Set the picture mode to suit your preference or requirements. Picture mode can be set to one of these options: **Standard, Vivid, Sport, Film** and **Game**. You can also manually adjust each mode. Available options may differ depending on the currently set input source.

Auto Backlight: Set the Auto backlight to **Off, Low, Medium, High**.

Brightness: Increases or decreases the picture brightness from 0 - 100.

Contrast: Adjusts the difference between light and dark levels in the picture. The range is from 0-100.

Colour: Adjusts the colour saturation of the picture. The range is from 0-100.

Sharpness: Adjusts the level of crispness in the edges between light and dark areas of the picture. Range is from 0-20.

Colour Temperature: The colour temperature setting has 4 preset settings: **User, Cool, Standard, Warm**, When

selected each of these settings has individual adjustments. Red, Green and Blue gain can all be adjusted from -20 to 20.

Picture Format: The picture format can be set to **Automatic, Superzoom, 4:3, Film Expand 14:9, Film Expand 16:9, Wide Screen** and **Full**.

Advanced Picture Settings

Hue: Increases or decreases the picture hue from -50 (reds) to 50 (greens).

Gamma: Choose from **Middle, Bright (standard)** or **Dark (film)**. Highlight your desired setting then press **Select**.

Colour Tuner: Colour Tuner can be switched on and off by selecting **Enable** option **On** or **Off**. Then you have 5 separate settings that can be individually adjusted. **Hue, Saturation, Brightness, Offset, Gain**.

11 Point White Balance Correction: Sets white balance of input image between cool or warm. 11 Point White Balance Correction can be switched on and off by selecting **Enable** option **On** or **Off**. Then you have 4 separate settings that can be individually adjusted. **Gain, Red, Green, Blue**. Gain can be adjusted from 5% to 100%, highlight your desired setting then press **Select**. Red, Green and Blue can be adjusted from 0 - 100, the default setting is 50.

Dynamic Noise Reduction: Dynamic Noise Reduction has 5 different settings: **Off, Low, Medium, Strong, Auto**. The default setting is **Medium**. Highlight your desired setting then press **Select**.

MPEG Noise Reduction: MPEG Noise Reduction has 4 different settings: **Off, Low, Medium, Strong**. The default setting is **Medium**. Highlight your desired setting then press **Select**.

Adaptive Luma Control: Makes higher depth impression by enhancing dark and bright areas. Adaptive Luma Control has 4 different settings: **Off, Low, Medium, Strong**. The default setting is **Low**. Highlight your desired setting then press **Select**.

Local Contrast Control: Divides each frame to small regions and applies independent contrast curves for every distinct region. Local Contrast Control has 4 different settings: **Off, Low, Medium, High**. The default setting is **Low**. Highlight your desired setting then press **Select**.

DI Film Mode: Compensates interlaced inputs for best image and motion quality. DI Film mode has 2 settings: **Auto** and **Off**. The default setting is **Off**. Highlight your desired setting then press **Select**.

If you require any technical guidance or find that your TV is not operating as intended, a simple solution can often be found in the **Help Menu**, or online at www.bush-support.co.uk. If you still require further assistance, call one of our experts on **0345 604 0105**, a Bush enquiry line.

Advanced features

Getting the most from your TV

Blue Stretch: Changes white balance of mid-high grey levels to cooler colour temperature. Blue Stretch can be switched **On** or **Off**.

Game Mode: Game Mode can be switched **On** or **Off**.

PC Mode: PC Mode can be switched **On** or **Off**.

HDMI RGB Range (HDMI input only): Sets correct interpolation method for HDMI input signals. HDMI RGB Range has 3 different settings; **Auto**, **Full**, **Limit**. The default setting is **Auto**. Highlight your desired setting then press **Select**.

HDMI Input Mode (HDMI input only): HDMI Input Mode has 4 different settings; **Mode 1 (1.4)**, **Mode 2 (2.0)**, **Auto**, **Reset**. The default setting is **Auto**. Highlight your desired setting then press **Select**.

Dolby Vision Notification: Dolby Vision notifications can be switched **On** or **Off**. Notifications are switch on as default.

Reset to Default: Resets all settings to factory default settings.

Adjusting the Sound Settings

Allows you to adjust the sound settings on your TV. You can access the sound settings menu via the **Settings** menu on the main screen or by pressing and holding the **Home** button for 2 seconds while viewing any input.

Accessing Sound Settings via Settings Menu

Press the **Home** button, scroll to **Settings** tab and press the **Select** button. Scroll to **Display & Audio** option and press the **Select** button. Scroll down to **Sound Settings** option and press the **Select** button. The sound setting options will appear on the right hand side of the screen.

Accessing Sound Settings while watching the TV

While watching the input that you would like to adjust press and hold the **Home** button for 2 seconds. The quick settings menu will appear on the right hand side of the screen. Scroll down and highlight **Sound** then press **Select**. The sound setting options will appear on the right hand side of the screen.

Sound Menu Content

The following options show all the available sound setting adjustment on your TV.

Dolby Audio: Dolby Audio has preset sound settings. The default setting is **Smart**. The settings are **Film**, **News**, **Music**, **Smart** and **Off**. They are designed to give you the best sound quality for the content that you are viewing. If you select **Smart** this will automatically detect the content you're watching and adjust the audio settings accordingly. Highlight your desired setting then press **Select**.

Sound Mode: Sound Mode can only be accessed if you have switched off **Dolby Audio**. Sound Mode has 6 different settings: **Standard**, **Music**, **Film**, **Clear Voice**, **Enhanced Bass**, **Flat**. The default setting is **Standard**. Highlight your desired setting then press **Select**.

Equaliser: This setting can only be accessed once **Dolby Audio** has been switched off. Equaliser has 5 different settings: **100Hz**, **500Hz**, **1.5kHz**, **5kHz**, **10kHz**. Each setting can be adjusted from -10 to 10, the default setting is 0 for all.

Balance: Adjusts the sound level from the left and right speakers and can be adjusted from -25 to 25. The default setting is 0.

Advanced Settings: Advanced Settings can only be accessed if you have switched off **Dolby Audio**. Here you will be able to switch **Dialog Clarity**, **DTS Virtual:X**, **TruVolume** and **TruBass** on or off. Highlight the desired option and press **Select** to switch on or off.

Dialog Clarity: Enhances signal clarity for clear dialogue that is audible above background sound effects.

DTS Virtual:X: Reproduces elevated sounds and a cinematic surround sound image without surround speakers.

TruVolume: Provides a consistent and comfortable volume level across content.

TruBass: Manages and enhances bass sound.

TV Speakers: Press **Select** to switch the TV speaker **On** or **Off**.

Reset: Resets all settings to factory default settings.

To Program Your SKY Remote For Your TV

1. Make sure your SKY box is connected to your TV
2. Turn your TV and SKY box on
3. Press TV on your SKY remote control handset
4. Hold down SELECT and the RED button together for about two seconds, until the red light on the SKY remote blinks twice.
5. Key in 0808 on your SKY remote. The light on the SKY remote should blink twice
6. Press the STANDBY button on your SKY remote control. Your TV should now switch off.
7. Press SELECT again. The light on your SKY remote control should now blink twice

You should now be able to control some basic functions on your TV from your SKY remote control (e.g. volume up/down, programme up/down).

If you require any technical guidance or find that your TV is not operating as intended, a simple solution can often be found in the **Help Menu**, or online at www.bush-support.co.uk. If you still require further assistance, call one of our experts on **0345 604 0105**, a **Bush enquiry line**.

Advanced features

Getting the most from your TV

*If this number does not work, please go to SKY website to find the alternative number to operate the TV.

Channel Guide

By means of channel guide function of your TV you can browse the event schedule of the currently installed channels on your channel list. It depends on the related broadcast whether this feature is supported or not.

In order to access the channel guide press the **Guide** button on the remote.

Use the directional buttons to navigate through the channel guide. You can use the Up/Down directional buttons to switch to previous/next channel on the list and Right/Left directional buttons to select a desired event of the currently highlighted channel. If available, the full name, start-end time and date of the highlighted event and a brief information about it will be displayed on the screen.

Guide Options

Press the **Options** button to display available options in the channel guide. You can filter channels, add channels to your favourite channel list or open the manage channels menu using these options. Highlight the one you want to use and press **Select**.

Filter Channels

If you receive channels via multiple broadcast methods you will have the choice here to filter via one of these options. For example if you select Terrestrial than you'll only see Terrestrial channels in the guide. Highlight the option you want and press **Select**.

After filtering channels **Show All Channels** option will be available in the options menu instead of **Filter Channels** option. You can use this option to cancel filtering in the channel list.

Add to Favourite Channels

Channels can be added to your favourite channel list so you can quickly and easily view your favourite channels without scrolling through the whole list of channels. You will see a heart symbol next to the channel which is added to your favourite channel list.

If a channel is already added to the favourites previously **Remove from Favourite Channels** option will be available in the options menu instead of **Add to Favourite Channels** option. You can use this option to remove the channel from favourite channel list.

Manage Channels

You can see all your channels, create favourite channels or hide channels that you don't want to appear in the

guide. The channels will be listed in 3 tabs; **All**, **Favourites** and **Hidden**.

In the **All** tab highlight a channel in the list and press the **Select** button to add it to favourites. Favourite channels will be listed in the **Favourites** tab. If the channel is already in the favourites list, it will be removed from the list when the **Select** button pressed.

In the **All** tab highlight a channel in the list and press **Play/Pause** button to hide it. Hidden channels will be listed in the **Hidden** tab. If the channel is already hidden, it will be visible again in the guide when the **Select** button pressed.

Settings

If you need to change or adjust anything on your TV you'll be able to find the required setting in the **Settings** menu. You can access the **Settings** menu from the main screen of the TV. Press **Home** button and scroll across to **Settings**. The settings menu is split into separate menus to make it easy for you to find what you're looking for.

Inputs

Use the **Inputs** menu to change between inputs and also select the **Media Player** from here if you have a USB Drive connected to one of the USB sockets.

Accessing the Inputs Menu

You can change/select inputs from the Navigation bar. Highlight the **INPUT** icon, the inputs will appear below the Navigation bar.

Selecting an Input

Press the left/right directional buttons to highlight your desired input then press **Select**. Your TV will now switch to that input.

Changing an Inputs Name

The input name can be changed for HDMI, Composite and VGA inputs. Highlight the input that you want to rename and press the **Options** button. Highlight **Change Device Name** and press **Select**. You'll now see a list of devices, highlight the one that you have connected and press **Select**. Then select **Next**.

If you want to set the inputs back to their original names, highlight the input, press **Option** and select **Reset Input**.

Media Player

If you have a USB storage device plugged into one of the USB sockets or you have files in **Gallery** you can access them and display them in the Media Player. The Media player allows you to display images, or play videos and audio files.

If you require any technical guidance or find that your TV is not operating as intended, a simple solution can often be found in the **Help Menu**, or online at www.bush-support.co.uk. If you still require further assistance, call one of our experts on **0345 604 0105**, a Bush enquiry line.

Advanced features

Getting the most from your TV

In the **Inputs** menu highlight **Media Player** and press **Select**. If this is the first time you have used the Media Player, you may be asked whether you want to allow gallery to access photos, media and files on your device. Gallery is the name used for your TV so highlight **Allow** and press **Select**.

With Media Player open you'll see 4 tabs at the top of the screen, highlight **Your Files** to see all the files, **Videos** to see all videos, **Images** to see all images and **Audio** to see all audio files.

Under these tabs view options will be available. **View All** option and the folders which include media files will be listed. When you scroll across an option, only the media files in the highlighted folder will be displayed on the screen. Highlight the **View All** option to see all files.

Press **Options** button, highlight **Sort** and press **Select** to see available options to sort the files displayed on the screen.

If you have multiple images on your USB Drive you can create a slide show using your images. Highlight the **Images** tab at the top of the screen then press the **Options** button. From the **Options** menu highlight **Multi-select Images** and press **Select**. Now select the images that you would like to add into the slide show by highlighting each image and pressing **Select**. Once you have selected all the images press the **Play/Pause** button to start the slide show.

Once you have a slide show running you can change the settings of the slide show. Press **Options** button to see available options. You can set the **Album**, **Slide Style**, **Slide Speed** and **Shuffle** options according to your preferences. Adjust the settings then press the **Play/Pause** button to view your slide show.

Supported file Video formats: MPG, MPEG, DAT, VOB, MKV, MP4, MOV, FLV, 3GP and AVI

Supported file Picture formats: JPEG, JPG, BMP and PNG

Supported file Music formats: MP3

Notifications

The Notifications menu shows you all the notifications about your TV. An orange dot will be displayed next to the **SETTINGS** icon on the **Home** screen to indicate that you have Notifications. A small number next to the Notifications symbol indicates how many notifications you have.

Reading Notifications

Highlight **Notifications** in the **Settings** menu and press **Select**. All the available notifications will be displayed.

Scroll across and highlight the notification that you want to read, then press **Select**. The notification message will be displayed on the screen.

Clearing Notifications

You can clear individual notifications or clear all of them. To clear an individual notification highlight the notification then press the **Options** button. In the **Options** menu highlight **Dismiss** and press **Select**. The notification will be deleted. To clear all the notifications press the **Options** button, highlight **Dismiss All** and press **Select**. All of the notifications will be deleted.

Managing Notifications

For the Appstore related notifications **Manage** option may be available. Highlight the notification and press the **Options** button. Highlight **Manage** and press **Select**. You will be directed to the **Notifications** setting option in the **Settings>Applications>Appstore** menu. Press **Select** to turn off the notifications related to Appstore.

Notification Settings

In order to configure the notification settings clear all notifications first. Press the **Options** button while "**No new notifications**" message is displayed on the screen, then highlight **Settings** and press **Select** to see available options. 2 options will be available. Use the **Do Not Interrupt** option to hide or show all application notification pop-ups. Use the **App Notifications** option to block or unblock notifications from individual apps.

Network

The **Network** menu has all the settings for connecting your TV to the internet. All the available networks will be shown here and this is where you can configure your network.

If you have connected your TV via an Ethernet cable or the **Enable Wi-Fi/Network** option is not set to ON, wireless networks will not be listed and wireless network related options will not be available.

Checking Network Status

Highlight **Network** in the **Settings** menu and press **Select**.

The **Network** menu will display the strongest 3 wireless networks your TV can find, your network is the one with the word 'Connected' written under it.

Highlight your network, if you're connected it will show **Connected** under the Network name. On the right of the screen it will show the **Signal Strength** and **Security** of your connection. With your network highlighted press the **Play/Pause** button to check your network. You will see connection status of your network. Press the **Back** button

If you require any technical guidance or find that your TV is not operating as intended, a simple solution can often be found in the **Help Menu**, or online at www.bush-support.co.uk. If you still require further assistance, call one of our experts on **0345 604 0105**, a Bush enquiry line.

Advanced features

Getting the most from your TV

to exit this screen. If you want to forget the network press the **Options** button while your network is highlighted.

Seeing All Networks

If you want to search for more networks, highlight **See All Networks** and press **Select**. You will now see a list of all the networks that your TV can find. If you scroll down to the bottom of the list you also have the option to rescan for networks.

Joining a Network Using WPS Button or PIN

If you can't remember your WLAN password using the WPS option temporarily disables your routers password and allows you to connect to it without it.

Highlight your preferred WPS connection option and press **Select**, then follow the on-screen instructions.

Advanced Network Settings

If you are confident in using network settings you can manually setup a network by highlighting **Join Other Network** and pressing **Select**. You will have to manually type in all your desired network settings using the on-screen keyboard.

If you have connected your TV via an Ethernet cable you can also configure your network settings. This is also a more advanced setting for users that are confident in setting up networks.

Saving your WLAN Password to your Amazon Account

Your WLAN password can be saved to your Amazon Account, this can be helpful if you would like to connect other devices to the same network. The default setting is **Off**.

Highlight **Save Wi-Fi Passwords to Amazon** and press **Select**. Your WLAN password will now be saved in your account. It can be deleted at any time by selecting **Off**.

Turning on your TV via LAN and WLAN

Enable devices and apps that you select to turn on your TV via LAN and WLAN. Turning this option on may increase your TV's power consumption.

If you enable network connection this option will also be enabled automatically. Highlight **Turn on with LAN and Wi-Fi** and press **Select** to disable.

Changing Connection Status

If you did not enable the network connection during the initial settings process, you can use this option to enable it. Or you can disable it if you enabled priorly.

Highlight **Enable Wi-Fi/Network** and press **Select** to enable or disable the network connection. Refer to **Connecting to the Internet** section if you need more information.

Display & Audio

This menu houses all the settings and adjustments for your picture and sound as well as other settings such as, how your TV powers on, screen mirroring, screen saver setting and HDMI CEC device control.

Highlight **Display & Audio** in the **Settings** menu and press **Select**.

Picture Settings

Picture settings can be adjusted on each input, so each input can be set to have its own picture settings. For information on adjusting each setting refer to the **Customising TV Settings** section of this manual.

For adjusting picture setting while viewing your TV, press and hold the **Home** button and select **Picture** in the menu on the right hand side of the screen.

Sound Settings

Sound settings can be adjusted here, for information on adjusting each setting refer to the **Customising TV Settings** section of this manual.

For adjusting sound settings while viewing your TV, press and hold the **Home** button and select **Sound** in the menu on the right hand side of the screen.

Power On

The Power On setting allows you to choose which state you want your TV to switch on in, either the last input that you were watching or the Home screen.

Highlight **Power On** and press **Select**. Highlight **Home** or **Last Input** and press **Select**. A tick will appear next to your choice.

Audio Output

The Audio Output menu has 5 options: **TV Speakers**, **Digital Audio Format**, **DTS DRC**, **AC4 Dialogue Enhancer** and **Bluetooth Audio Sync**.

Highlight **Audio Output** and press **Select**.

TV Speakers: In the TV Speakers menu you can switch your TV's built-in speakers on or off. You may wish to switch them off if you have connected a soundbar.

Highlight **TV Speakers** and press **Select** to switch the TV Speakers on or off.

Digital Audio Format: Depending on the type of audio device you have connected you may need to adjust the audio format that your TV outputs. The audio format can be changed here.

Highlight **Digital Audio Format** and press **Select**.

Highlight your desired audio format **PCM**, **Dolby Digital**, **Auto**, **Pass-through** then press **Select**. The default setting is **Auto**.

Advanced features

Getting the most from your TV

DTS DRC: The DTS DRC menu enables DTS DRC to be switched on or off.

Highlight **DTS DRC** and press **Select** to switch the DTS DRC to on or off.

AC4 Dialogue Enhancer: AC-4 Dialogue Enhancer increases the clarity of the dialogue, even with older, previously recorded stereo and surround content.

Highlight **AC4 Dialogue Enhancer** and press **Select**.

Off, Low, Medium and **High** options will be available. Highlight your desired option then press **Select**. The default setting is **Off**.

Bluetooth Audio Sync: If you have a Bluetooth speaker or headphones connected to your TV you might need to sync the audio to your device. Selecting this option will do this for you.

With your Bluetooth device connected to your TV highlight **Bluetooth Audio Sync** and press **Select**.

Enable Display Mirroring

Enable mobile devices to temporarily mirror their display to your TV, by making it discoverable. This referred to as Display Mirroring or Miracast on your device.

Highlight **Enable Display Mirroring** and press **Select**. **Display Mirroring** screen will be displayed. Your TV is ready now for display mirroring.

Navigation Sounds

While navigating menus and selecting items your TV will make a sound, this can be switched on and off here.

Highlight **Navigation Sounds** and press **Select** to switch them on or off.

Screen Saver

When your TV is inactive for a few minutes the screen saver will activate. Pictures from the Amazon Collection will play. The screen saver menu gives you many options to change so that you can customise your screen saver. If your TV is not connected to the internet **Screen Saver** option will not be available.

Highlight **Screen Saver** and press **Select**.

The **Screensaver Settings** menu will appear.

Current Screensaver - Here you can change the screen saver album so it shows your pictures.

Slide Style - Change the way the pictures transition. Choose from **Pan & Zoom, Dissolve**.

Slide Speed - Adjust the time taken to change pictures. Choose from **Slow, Medium** or **Fast**.

Start Time - Set the time taken before the Screen Saver starts. Choose from **5, 10, 15 minutes** or **Never**.

Display Info - Switch the picture information on or off.

Alexa Hints - Switch the Alexa hints on or off.

Shuffle - Switch this option on if you want to display pictures in a random order.

HDMI CEC Device Control

If you have a CEC enabled device connected to your TV via a HDMI cable, this setting allows your TV remote control to also control selected functions of your connected device. For example the **Standby** button on your TV remote will also switch on your CEC enabled device. The default setting is **ON**.

Highlight **HDMI CEC Device Control** and press **Select** to switch on or off.

Applications

The applications menu lets you manage all your apps.

Highlight **Applications** and press **Select**.

Amazon Photo Settings

Here you can change the Amazon photo app settings, you can allow others to cast photos from their Amazon Photos account to your TV, and you can also disable your account so it can't be viewed on your TV.

Highlight **Amazon Photos** and press **Select**. A confirmation dialogue will be displayed. Highlight **Disable** and press **Select** to continue.

Allow Guest Connections is switched on as default, if you don't want to allow other users to cast photos from their Amazon Photo accounts you can switch this feature off. Highlight **Allow Guest Connections** and press **Select** to switch the feature on and off.

If you want to stop seeing your photos from your Amazon Photos account you can disable the feature here. Access is enabled as default. Highlight **Access Amazon Photos** and press **Select**. Highlight **Disable Amazon Photos** and press **Select**. Your photos will now not be viewable on your TV. Don't worry your photos will not be deleted they will remain in your account.

Saving Gaming Progress

In some gaming apps your progress can be saved on the cloud by Whispersync, you can switch this on or off using the **GameCircle** option.

Highlight **GameCircle** and press **Select**.

Highlight **Whispersync for Games** and press **Select** to switch on or off. The default setting is **ON**.

If you require any technical guidance or find that your TV is not operating as intended, a simple solution can often be found in the **Help Menu**, or online at www.bush-support.co.uk. If you still require further assistance, call one of our experts on **0345 604 0105**, a **Bush enquiry line**.

Advanced features

Getting the most from your TV

Appstore

This menu allows you to control your app setting such as auto updates, in-app purchases and how to open external market links.

Highlight **Appstore** and press **Select**.

The Appstore menu will be displayed where you can select the following:

Manage Installed Applications: View and manage installed applications, including force stop, uninstall, clear data and clear cache.

External Market Links: Gives you the choice of how you want external links to open. Press **Select** to see the available options: **Open with the Amazon Appstore**, **Don't Open** and **Ask Before Opening**. Highlight the option you prefer and press **Select**. A tick will appear next to your choice.

In-App Purchases: Some apps have in-apps purchases that can be made, this setting lets you choose if you want to allow them or not.

Press **Select** to switch on or off.

Manage My Subscriptions: You can manage your subscriptions online.

Follow the link shown on the screen.

Notifications: Set to **ON** to display notifications relating to Appstore. Press **Select** to switch on or off.

Hide Cloud Apps: In your app library you can hide Apps that you own but are not installed. This will make it easier to browse your installed apps. Press **Select** to switch on or off.

Manage Installed Applications

Here you can manage all the apps on your TV. It will also show you the amount of available memory left on your TV. Highlight **Manage Installed Applications** and press **Select**.

The default setting is for it to show all apps, however if you highlight **Show** and press **Select** you get the options to show **All Applications**, **Internal Only** or **USB Only**.

A list of apps will be displayed, highlight the app that you'd like to manage and press **Select**.

Pre-installed apps have 3 options, apps that you have downloaded and installed have more options. If you uninstall an app it will still be available for you to download and re-install again in the future.

Pre-installed apps

You will have 3 options **Force stop**, **Clear data**, and **Clear cache**.

Installed apps

You will have some extra options: **Permissions**, **Launch application** and **Uninstall**.

Equipment Control

Soundbars and receivers can be connected to your TV and here they can be setup so that your Fire TV remote and Alexa can control the connected device no matter how you connected it to your TV. This process will take a while to setup so please be patient.

Adding a Soundbar or Receiver

Highlight **Add Equipment** and press **Select**.

Highlight either **Soundbar** or **Receiver** depending on the product that you have connected then press **Select**.

Note: Make sure your soundbar or receiver is connected to your TV and switched on.

The following example shows how to setup a soundbar. Now you need to select the brand of your soundbar. Highlight the brand then press **Select**.

Make sure your soundbar is switched on and the volume is up then press **Select**.

Press **Standby** on your TV remote control, wait 10 seconds then press the **Standby** button again.

You'll now be asked 'Did your soundbar turn off and then back on when you pressed **Standby**'. If it did highlight **Yes** and press **Select**, if it didn't highlight **No** and press **Select**. You may need to repeat this process multiple times.

When your soundbar eventually turns off and on, you will be asked to press the volume up and down buttons. Press the **Volume +** and **-** buttons.

If your volume level adjusted as expected highlight **Yes** and press **Select**. If not select **No** and continue until the volume level changes.

Your Fire TV remote has now been setup, it will now switch your soundbar on and off and adjust the volume level.

Now when you switch your TV on your soundbar will also switch on. The TV speakers will be automatically switched off.

Soundbar/Receiver Settings

Once you have setup your soundbar or receiver you will now see either **Soundbar** or **Receiver** in the **Equipment Control** menu. This will show you all the settings for your device.

Highlight **Soundbar** or **Receiver** and press **Select**. You will now see a list of settings.

Advanced features

Getting the most from your TV

Highlight the setting that you wish to adjust and press **Select**.

Volume Increments: Set the amount the volume increases or decreases when you ask Alexa to change the volume. The default increment is set to 4.

Press **Rewind** or **Fast Forward** to increase or decrease the increments. Press **Option** to restore back to default settings.

Infrared Options: Changes the infrared options. **IR Profile, Timing** and **Repetition** options will be available.

Power Controls: Adjusts the power on/off settings for your soundbar or receiver. **Power On Delay, Power Command** and **Power Control** options will be available.

Fire TV Input: Change the input, to which your soundbar or receiver will switch to for watching Fire TV.

Change Soundbar /Change Receiver: If you would like to change the soundbar or receiver that's connected to your TV select Change Soundbar/Change Receiver.

Restore Soundbar Defaults /Restore Receiver Defaults Restores all the settings that you may have changed back to factory defaults. This option will be available if you change the default settings.

Advanced Settings

Adjust the power timing if your soundbar or receiver does not switch on/off.

Press **Rewind** or **Fast Forward** to increase or decrease the increments.

Press **Option** to restore back to default settings.

Live TV

This menu allows you to tune in your TV, manage the channels, set up a CI card and set parental controls.

Highlight **Live TV** and press **Select**.

Tuning in your TV

You should have already tuned in your TV during the initial setup process. But if you skipped the channel scan step or if you need to retune your TV follow these instructions.

Highlight **Channel Scan** and press **Select**.

You will be asked to check if your antenna cable is plugged properly into the antenna input socket on your TV. Press **Select** to proceed.

Highlight the country that you are in and press **Select**.

Select your scanning preference to install channels. **TV** options will be available.

After selecting an option, the TV will search for digital terrestrial broadcasts. Select the searching method and press **Select** to start search.

You will be asked at some point whether you want to clear existing channels, if you have installed channels previously using the same search option. Highlight **Yes** and press **Select**. All the previously tuned in channels will be deleted. Highlight **No, keep existing** and press **Select** to proceed without clearing existing channels.

While the search continues you can press the **Select** button to cancel. When the initial setup is completed the results will be displayed. You can choose to make changes on the channel list or rescan at this point. Highlight **Done** and press **Select** to finish the setup.

Automatic Service Update

You can allow your TV to automatically scan for network operator changes when TV enters standby mode. Press **Select** to turn this feature on and off.

Favourite Channels

You can view and manage your favourite channels here.

Highlight **Favourite Channels** and press **Select**.

If you do not have any favourite channels press **Select** to add channels. Then select the source to view the channel list. Highlight a channel and press **Select** to add this channel to your favourites.

If you have priority added channels to your favourites you can press **Select** to select the channels you want to remove from your favourites. Then press **Play/Pause** to confirm.

Manage Channels

Manage your favourite channels and select the channels you want to display.

Highlight **Manage Channels** and press **Select**. Then select the channel type. Available. Available options may differ depending on the currently installed channel types.

You will now see the channel list with 3 tabs: **All**, **Favourites** and **Hidden**.

All will show all the channels, **Favourites** will show all the channels you marked as favourite channels and **Hidden** will show all the hidden channels.

In the **All** tab you can choose to add a channel to the favourites list by pressing **Select** or you can hide a channel by pressing **Play/Pause**.

Live TV Sources

Manage your Live TV sources.

CI Card

Access your CI Card settings and information.

If you require any technical guidance or find that your TV is not operating as intended, a simple solution can often be found in the **Help Menu**, or online at www.bush-support.co.uk. If you still require further assistance, call one of our experts on **0345 604 0105**, a **Bush enquiry line**.

Advanced features

Getting the most from your TV

Parental Controls

Restrict over-the-air films, TV shows, purchasing and certain types of content.

Highlight **Parental Controls** and press **Select**.

The default setting is **OFF** so press **Select** to switch on.

Note: You will be asked to enter a PIN to turn the parental controls on or off. This is the Prime Video PIN and it is related to your Amazon account. If you have forgotten your PIN follow the link shown on the screen to reset your PIN.

The first time you enable **Parental Controls** you'll see some brief information about the settings. Press **Select** to continue.

You'll now see all the settings that can be adjusted. Highlight your desired setting and press **Select**.

Parental Controls: Press **Select** to switch parental controls on or off.

PIN-Protect Purchases: Asks for a PIN before any video, apps or games purchases. Press **Select** to turn on or off.

Prime Video Ratings: Restricts viewing of videos based on ratings. The default setting for **General** and **Family** rating is On, for **Teen**, **Young Adults** and **Mature** ratings is Off. Highlight the desired rating option and press **Select** to change the setting.

Note: These settings apply to Prime Videos (including Amazon Channels). Videos from other service providers may have their own restriction settings.

Broadcast Ratings: Use ratings to restrict the viewing of Live TV programmes from over-the-air broadcast TV accessed directly from the Fire TV user interface, such as **Guide** or **On Now** row. Visit third-party apps to manage settings for content accessed within those apps.

- DVB 4 (Child) - DVB 18 (Adult)
- All settings are switch on as default

PIN-Protect App Launches: Asks for a PIN before launching apps and games. This setting will not apply to the content accessed directly from the Fire TV user interface, such as the **Guide** or **On Now** row. Press **Select** to turn on or off.

PIN-Protect Amazon Photos App: Asks for a PIN before launching Amazon Photos. This setting will be ignored if you have already set **PIN-Protect App Launches** to **ON**. Press **Select** to turn on or off.

Change PIN: Change the Prime Video PIN. First enter your current PIN, then enter your new PIN.

If you have forgotten your PIN follow the link shown on the screen to reset your PIN.

Remotes & Bluetooth Devices

You can add an extra Alexa Voice Remote to your TV, or you may also need to replace one if your old one broke. Other bluetooth devices like speakers, games controllers, mice and keyboards can also be connected via bluetooth. Highlight **Remotes & Bluetooth Devices** and press **Select**.

Adding or Viewing Status of Alexa Voice Remotes with Alexa

Check the status of your current Alexa Voice Remote with Alexa or add a new one.

Highlight **Alexa Voice Remotes with Alexa** and press **Select**.

Remote Status

To see the status of your current Alexa Voice Remote highlight the remote option and look at the right hand side of the screen. You will see the type of remote control, the battery status, the version number and its serial number.

To unpair the remote press the **Options** button while the remote option is highlighted then press **Select** to confirm. **Options** button will have no function if only one remote is paired.

Adding New Remote

Highlight **Add New Remote** and press **Select**.

You'll see the word 'Searching' appear, press and hold the **Home** button on the new remote control for 10 seconds. When the remote has been discovered it will appear in the list.

Adding a Bluetooth Game Controller

Bluetooth gaming controllers can be connected to your TV which can be used to enjoy all the gaming apps on your TV.

Highlight **Game Controllers** and press **Select**.

Highlight **Add New Game Controller** and press **Select** to search for new controllers.

You'll see the word 'Searching for Controllers' appear on the right hand side of the screen. Make sure your controller is discoverable and ready to pair. Follow the on-screen instructions. When the controller has been discovered it will appear in the list. Select your controller from the list.

Adding a Bluetooth Device

You can connect other bluetooth devices such as a mouse or a keyboard, which can be handy when using the internet browser.

Highlight **Other Bluetooth Devices** and press **Select**.

If you require any technical guidance or find that your TV is not operating as intended, a simple solution can often be found in the **Help Menu**, or online at www.bush-support.co.uk. If you still require further assistance, call one of our experts on **0345 604 0105**, a Bush enquiry line.

Advanced features

Getting the most from your TV

Make sure your bluetooth device is in pairing mode and then highlight **Add Bluetooth Devices** and press **Select**.

Your device will appear in the list, this could take a minute or so. Then highlight the device and press **Select** to connect the device.

Alexa

This menu has more information about the Alexa app, examples of things to try, and you can also allow your TV to be switched on by your Amazon Echo speakers.

Highlight **Alexa** and press **Select**.

Alexa app

To find out more information about the Alexa application and where to download it select **Alexa app**. You will need this app if you want to let your Amazon Echo speakers control your TV. The app is the place where you'll be able to connect all your Amazon devices together.

Highlight **Alexa app** then press **Select**, you will now see information about the application and where to download it.

Things to Try

For lots of examples of what you can use Alexa for, look in this section. You will find many ideas.

Highlight **Things to Try** then press **Select**, you will see a list of things to try.

Highlight something in the list and then press **Select** to see more information.

Turn on TV with Alexa

If you have another Alexa Enabled device it can be allowed to be used to control your TV. You will need to set **Turn on TV with Alexa** option to **ON** and also make some other adjustments in the Alexa app.

Highlight **Turn on TV with Alexa** then press **Select** to switch the feature on. A confirmation dialogue will be displayed on the screen. Highlight **Yes** and press **Select** to proceed.

Note: Enabling this setting may increase your TV's power consumption.

Preferences

The preferences menu is where you'll find adjustment to lots of the settings on your TV. Things like parental controls, privacy and data setting and restricting access to certain content and purchases.

Highlight **Preferences** and press **Select**.

Setting Parental Controls

Your TV has some default protections which when enabled will require a PIN code to be entered for purchases, app launches and it will also restrict viewing of content rated Teen and above. Parental controls are set to **OFF** as default.

Highlight **Parental Controls** and press **Select** to switch parental controls on.

Note: You will be asked to enter a PIN to turn the parental controls on or off. This is the Prime Video PIN and it is related to your Amazon account. If you have forgotten your PIN follow the link shown on the screen to reset your PIN.

Refer to **Parental Controls** section under the **Live TV Menu** title for more information.

Privacy Settings

You can manage all of your TV's privacy settings here. Highlight **Privacy Settings** and press **Select**.

You will now see a list of all the settings that can be adjusted, highlight the setting that you would like to adjust and press **Select**. The possible settings are as follows.

Device Usage Data: Allows use of personal data collected by the operating system of this TV for marketing and product improvement purposes. The default setting is **ON** (Allow). Highlight and press **Select**. You will be informed about this feature. Use directional buttons to read the entire text. To turn this feature off highlight **Turn Off** and press **Select**.

Collect App and Broadcast Usage Data: Allows Amazon to collect information relating to your use of broadcast TV content, as well as the frequency and duration of your use of third-party apps. The default setting is **ON** (Allow). Highlight and press **Select**. You will be informed about this feature. To turn this feature off highlight **Turn Off** and press **Select**.

Interest-based Ads: If you opt out of interest-based ads on your TV, apps will be instructed not to use the advertising ID to build profiles for advertising purposes or target you with interest-based ads on your TV. The advertising ID is a resettable identifier that can be used to build profiles or show you interest-based ads. The default setting is **ON** (Allow). Press **Select** to turn off.

Your Advertising ID: Shows your Advertising ID on the right hand side of the screen. Press **Options** button to reset your ID. A confirmation dialogue will be displayed. Highlight **OK** and press **Select** to reset. This option will be available if the **Interest-based Ads** option is set to **ON**.

Data Monitoring

You can manage all your data usage here.

Highlight **Data Monitoring** and press **Select** to switch on and adjust any settings. Data monitoring is set to **OFF** as default.

Data Monitoring: Switching on allows you to monitor your data consumption. The default setting is **OFF**.

Set Video Quality: This allows you to choose the video quality on Amazon Video. The default setting is **Best**.

If you require any technical guidance or find that your TV is not operating as intended, a simple solution can often be found in the **Help Menu**, or online at www.bush-support.co.uk. If you still require further assistance, call one of our experts on **0345 604 0105**, a **Bush enquiry line**.

Advanced features

Getting the most from your TV

Available options are **Good** (least amount of data used), **Better** and **Best** (most amount of data used).

Set Data Alert: Set a data limit and receive on-screen alerts when consumption reaches 90% and 100% of the limit. This is just an alert and will not block data consumption.

Monthly Top Data Usage: Displays a list of your apps and shows individual data usage for the monthly billing cycle specified in the **Set Data Alert** option.

Notification Settings

You can manage all your notifications here, turn off all notification pop-ups or block/unblock notifications from specific apps.

Highlight **Notification Settings** and press **Select**.

To switch on/off notification pop-ups highlight **Do Not Interrupt** and press **Select**.

To block or unblock notifications from individual apps, highlight **App Notifications** and press **Select**. You'll see a list of your apps, it will show if notifications are **ON** or **OFF**. To adjust this highlight an app and press **Select** to switch between **ON** and **OFF**.

Featured Content

The Home screen has featured content at the top, when you select this content it will play a preview of the content. In this menu you can choose if the content plays or not and also switch the audio of this content on and off.

Highlight **Featured Content** and press **Select**.

Highlight either **Allow Video Autoplay** or **Allow Audio Autoplay** and press **Select** to switch the feature on or off. The default setting is **ON** for both.

Allow video autoplay

ON - The video will automatically play.

OFF - A still image will appear and no audio will be heard.

Allow audio autoplay

ON - Audio will be heard when the video plays.

OFF - No audio will be heard when the video plays.

Auto Power Off

Your TV will automatically switch off after 4 hours of no activity. This feature is to help save energy if your TV was accidentally left on. If you have been watching your TV for 4 hours without pressing any buttons, a warning will appear telling you it's about to turn off. If you wish to continue watching at this stage highlight **OK** and press **Select**.

To switch off this feature, highlight **Auto Power Off** and press **Select**. Your TV will now not switch off after 4 hours of inactivity.

Sync Recent Content

You can include Prime Video titles watched on other devices in the **Recent** row on this device.

Highlight **Sync Recent Content** and press **Select** to switch this feature on or off.

Location

It's handy that your TV knows where it is in the world so when you ask Alexa a question like 'Alexa, what's the weather outside?' it can tell you the weather in your location.

Highlight **Location** and press **Select**.

Enter your Postcode using the onscreen keyboard then select **Next** and press **Select**. Your location will now be saved.

Time Zone

In this menu you can set your clock to display as a 24 hour clock and you can also change your time zone.

Highlight **Time Zone** and press **Select**.

To switch 24 hour time format on/off highlight **24-Hour Time** and press **Select**.

To change your time zone, highlight **Time Zone** and press **Select**.

Sync Date and Time

Your TV will automatically synchronise date and time with an internet time server. If you switch this feature off your TV will sync with broadcast time. This may result in network connection and playback issues. You must restart your Fire TV if you choose to switch this feature on again.

Highlight **Sync Date And Time** and press **Select** to switch it on or off.

Language

You can change the system language.

Highlight **Language** and press **Select**.

Choose your desired language from the list of languages and press **Select**.

Metric Units

This option will be set to **ON** by default. Temperatures and distances will be displayed in metric units.

Highlight **Metric Units** and press **Select** to switch on or off.

Sleep Timer

The sleep timer function lets you set a countdown to when your TV will switch off, so that you can fall asleep while watching TV knowing it will automatically switch off. You can set a countdown from 5 - 240 minutes.

Highlight **Sleep Timer** and press **Select**.

Highlight the amount of time you want until your TV switches off and then press **Select**.

If you require any technical guidance or find that your TV is not operating as intended, a simple solution can often be found in the **Help Menu**, or online at www.bush-support.co.uk. If you still require further assistance, call one of our experts on **0345 604 0105**, a **Bush enquiry line**.

Advanced features

Getting the most from your TV

A countdown will start in the bottom corner of the screen. You can also switch off the countdown by highlighting **Off** and pressing **Select**.

Note: The TV will switch off once the sleep time has elapsed, a 1 minute warning will be shown.

Device & Software

This menu will give you information about your TV, show you legal and compliance documents. You can also restart or reset your TV back to factory defaults.

Highlight **Device & Software** and press **Select**.

About

If you need to find out any information about your TV it should be displayed here. You'll also see storage and network information and you will also be able to check for any available software updates.

Highlight **About** and press **Select**.

Your TV: Displays information related to your TV.

Storage: Show the available storage space on your TV and on any external device that's connected.

Network: Displays all the information related to network settings.

Check for Updates: Displays your current software version and when it was last updated. Press **Select** to check for any new updates.

USB Drive

This menu will show you the available space on your drive. You will also be able to eject or format the drive. This menu will only appear if you have a USB drive connected.

Highlight **USB Drive**, the space available will be shown on the right hand side of the screen.

Ejecting a USB Drive

Highlight **USB Drive** and press **Select**.

Then highlight **Eject USB Drive** and press **Select**. Now remove your drive from the USB socket. The menu will return back to the **Device & Software** root menu.

Formatting a USB Drive

Important: Formatting the USB drive will erase all information on the USB drive. Once formatted this USB drive can only be used by this TV.

Select this option if you intend your TV to use apps stored on this drive.

Highlight **Format to Internal Storage** then press **Select**.

When formatting is complete select **OK**.

Developer Options

Enable ADB connections over the network.

Highlight **Developer Options** and press **Select**.

ADB Debugging: Press **Select** to turn on and off. Turn on to enable ADB connections over the network.

Note that, turning this feature on will allow anyone on your network to install applications from untrusted sources.

USB Debugging: Press **Select** to turn on and off. Turn on to enable ADB connections over USB for this power cycle. This option will not be available if **ADB Debugging** is set to **OFF**.

Note that, turning this feature on will make USB accessories unavailable.

Install unknown apps: If you have installed an application that requests permission to install other applications and you want to grant permission, you can do this using this option.

Legal & Compliance

To read all the legal and compliances notices regarding your TV select this menu.

Highlight **Legal & Compliance** then press **Select**.

Note: Your TV will need to be connected to the internet to access Legal & Compliance information.

Sleep

Your TV can be put to sleep.

Highlight **Sleep** then press **Select**. Your TV will go to sleep. You can wake it up again by pressing the **Standby** or **Select** button.

Restart

If for some reason your TV is slow or locking up you may want to restart it. This will re-boot your TV.

Highlight **Restart** then press **Select**. Confirm you want to restart by selecting **Restart** and then press **Select**. Your TV will now restart, this will take a few seconds.

Reset to Factory Defaults

If you want to totally reset your TV select **Reset to Factory Defaults**. This will remove all personal data and downloaded content from your TV. You should do this if you sell your TV or give it to someone.

Highlight **Reset to Factory Defaults** then press **Select**. Confirm you want to reset by selecting **Reset** and then press **Select**. Your TV will now reset itself back to the state it left the factory. This process will take a few minutes.

Advanced features

Getting the most from your TV

Accessibility

This menu has accessibility options where you can switch on **Subtitle**, **VoiceView**, **Text Banner**, **Screen Magnifier**, **High-Contrast Text** and **Audio Description**.

Highlight **Accessibility** and press **Select**.

Subtitle

Displays subtitles on all content when available. Press **Select** to switch subtitles on and see more options.

VoiceView

Provides spoken feedback as you navigate items on the screen. Manage voice guidance settings including turning **VoiceView** on and off, reading speed and volume.

Text Banner

Displays text related to the focused item in a box with customisable font size, colours and more. Toggle the text banner on and off.

Screen Magnifier

Enables the use of button combinations to magnify the screen. Only for use when viewing the Home screen or menus.

Highlight **Screen Magnifier** and press **Select**.

The button combinations will be displayed. Highlight **OK** and press **Select** to continue. Highlight **TURN OFF MAGNIFIER** and press **Select** to turn it off.

You can also press and hold the **Back** and **Fast Forward** buttons to activate/deactivate screen magnifier.

Once the magnifier is activated you will see a yellow box at the top of the screen. Press **Options** button and a directional button at the same time to pan around the screen.

High-Contrast Text

Changes text to black or white and adds a border.

Audio Description

This setting controls the volume of the descriptive track related to the normal track for over-the-air channels and Prime Video content.

Highlight **Audio Description** and press **Select**.

Highlight the option you want and press **Select** to set. You can set **Over-the-Air Channels** option to **Off**, **Low**, **Medium** or **High** and the **Prime Video** option to **ON** or **OFF**.

Help

If you are struggling to understand how your TV works and you need a little help then you should take a look at this menu. It will show you helpful videos and quick tips about your TV. It will also give you contact details for getting support about any issue you have.

Highlight **Help** then press **Select**.

Help Videos

Your TV has helpful videos that you can watch to help you understand how to use your TV.

Note: New helpful video will be added every time your TV updates, so the amount of content here will change from time to time.

Quick Tips

Your TV has a list of quick tips that you can read to understand how to use your TV or to solve a problem you may have encountered.

Contact Us

If you feel you need more help with your TV, select the related section where you will find details of how to get in touch with a support team.

Highlight **Contact Us** and press **Select**.

Feedback

Highlight **Feedback** to display information on where you can send us feedback about your Fire TV experience.

Account & Profile settings

Here you can deregister your account or synchronise your purchased Amazon content.

Highlight **My Account** and press **Select**.

Amazon Account

If you wish to remove your Amazon account from the TV you will need to deregister it. This will not delete your Amazon account it will just remove it from this TV. After deregistering your account this will remove content from your TV and many features will not work, until a new account is registered.

Highlight **Amazon Account** and press **Select**.

Then highlight **Deregister** and press **Select** to deregister your account. This will take a few seconds.

Important: Deregistering an account will NOT remove all personal data. To remove all personal data you will need to factory reset your TV. To do this go to **Settings > Device & Software > Reset to Factory Defaults**.

Once the account has been deregistered the **Sign In with Your Amazon Account** screen will be displayed so you can sign in using another account.

Sync Amazon Content

If you have purchased content such as movies, these can be viewed on other devices by synchronising Amazon content.

Highlight **Sync Amazon Content** and press **Select**. The word 'Synchronising' will appear. Your purchased content will now be viewable on other devices.

If you require any technical guidance or find that your TV is not operating as intended, a simple solution can often be found in the **Help Menu**, or online at www.bush-support.co.uk. If you still require further assistance, call one of our experts on **0345 604 0105**, a **Bush enquiry line**.

Advanced features

Getting the most from your TV

Prime Video

Information on where you can manage your subscriptions and transactions will be displayed.

Connecting to the Internet

You can access the Internet via your TV, by connecting it to a broadband system. It is necessary to configure the network settings in order to enjoy a variety of streaming content and internet applications. These settings can be configured from **Settings>Network** menu.

Wired Connection

Connect your TV to your modem/router via an Ethernet cable. There is a LAN port on the rear side of your TV. Your TV will not automatically connect to the network. You will need to enable it manually using the **Enable Wi-Fi/Network** option in the **Network** menu. Highlight this option and press **Select** to enable.

You can check the status of the connection using the **Ethernet Configuration** option in the **Network** menu. Highlight this option and press **Play/Pause** button on the remote to see the network status.

To configure your wired connection settings manually highlight **Ethernet Configuration** and press the **Select** button. Follow the on-screen dialogues to proceed and enter the required values respectively.

If the Ethernet cable is not connected, depending on the current connection status, **Configure Ethernet Connection** or **Configure Network** option will be available instead of **Ethernet Configuration** option.

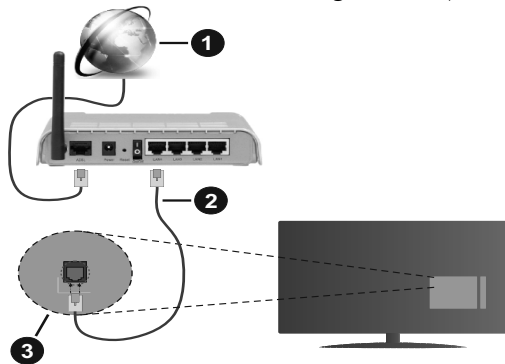

1. Broadband ISP connection
2. LAN (Ethernet) cable
3. LAN input on the rear side of the TV

You might be able to connect your TV to a network wall socket depending on your network's configuration. In that case, you can connect your TV directly to the network using an Ethernet cable.

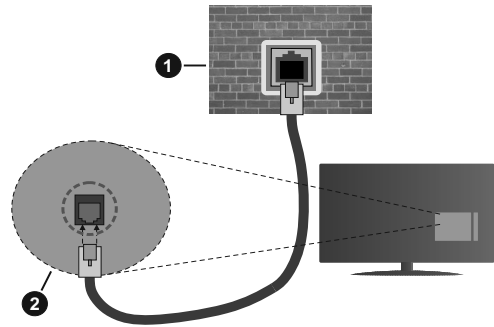

1. Network wall socket
2. LAN input on the rear side of the TV

Wireless Connection

A wireless LAN modem/router is required to connect the TV to the Internet via wireless LAN.

Highlight **Enable Wi-Fi/Network** option in the **Network** menu and press **Select** to enable wireless connection. Then disconnect the Ethernet cable, if connected priorly. Some of the available networks will be listed. Highlight **See All Networks** and press **Select** to see the complete list.

If you prefer to connect your TV to your network via WLAN you have 3 ways to do this.

- Highlight one of the listed available wireless networks and press **Select**. Then enter the password if the network is password protected.
 - Use the WPS button on your router. Highlight **Join Network Using WPS (Button)** option and press **Select**. Press the WPS button on your router. Your TV will connect to your router, without the use of a password.
- Note:** During the initial setup process **Connect using WPS Push Button** option will be available instead of **Join Network Using WPS (Button)** option.
- Enter WPS PIN on your router. Highlight **Join Network Using WPS (PIN)** option and press **Select**. A code will be created and displayed on the screen. Enter this code on your router. Your TV will connect to your router, without the use of a password.

Note: During the initial setup process **Connect using WPS PIN** option will be available instead of **Join Network Using WPS (PIN)** option.

If you require any technical guidance or find that your TV is not operating as intended, a simple solution can often be found in the **Help Menu**, or online at www.bush-support.co.uk. If you still require further assistance, call one of our experts on 0345 604 0105, a Bush enquiry line.

Advanced features

Getting the most from your TV



1. Broadband ISP connection

A network with hidden SSID can not be detected by other devices. If you want to connect to a network with hidden SSID, highlight the **Join Other Network** option under the **Network** menu and press **Select**. Add the network by entering its name, security type and password manually. If you want to configure additional settings of the network manually, highlight **Advanced** when prompted and press **Select**. Follow the on-screen instructions to proceed and enter the required values respectively.

If you want to save the wireless network passwords to Amazon you can use the **Save Wi-Fi Passwords to Amazon** option. To delete saved passwords turn this option off.

A Wireless-N router (IEEE 802.11a/b/g/n/ac) with 2.4 and 5 GHz bands is designed to increase bandwidth. These are optimised for smoother and faster HD video streaming, file transfers and wireless gaming.

Use a LAN connection for quicker data transfer between other devices like computers.

The transmission speed differs depending on the distance and number of obstructions between the transmission products, the configuration of these products, the radio wave conditions, the line traffic and the products that you use. The transmission may also be cut off or may get disconnected depending on the radio wave conditions, DECT phones or any other WLAN 11b appliances. The standard values of the transmission speed are the theoretical maximum values for the wireless standards. They are not the actual speeds of data transmission.

The location where the transmission is most effective differs depending on the usage environment.

The Wireless feature of the TV supports 802.11a,b,g,n & ac type modems. It is highly recommended that you should use the IEEE 802.11ac communication protocol in order to avoid any possible problems while watching videos.

You must change your modem's SSID when there are any other modems around with the same SSID. You can encounter connection problems otherwise. Use a wired connection if you experience problems with a wireless connection.

A stable connection speed is required to play back streaming content. Use an Ethernet connection if the wireless LAN speed is unstable.

If you require any technical guidance or find that your TV is not operating as intended, a simple solution can often be found in the **Help Menu**, or online at www.bush-support.co.uk. If you still require further assistance, call one of our experts on **0345 604 0105**, a **Bush enquiry line**.

Other information 6

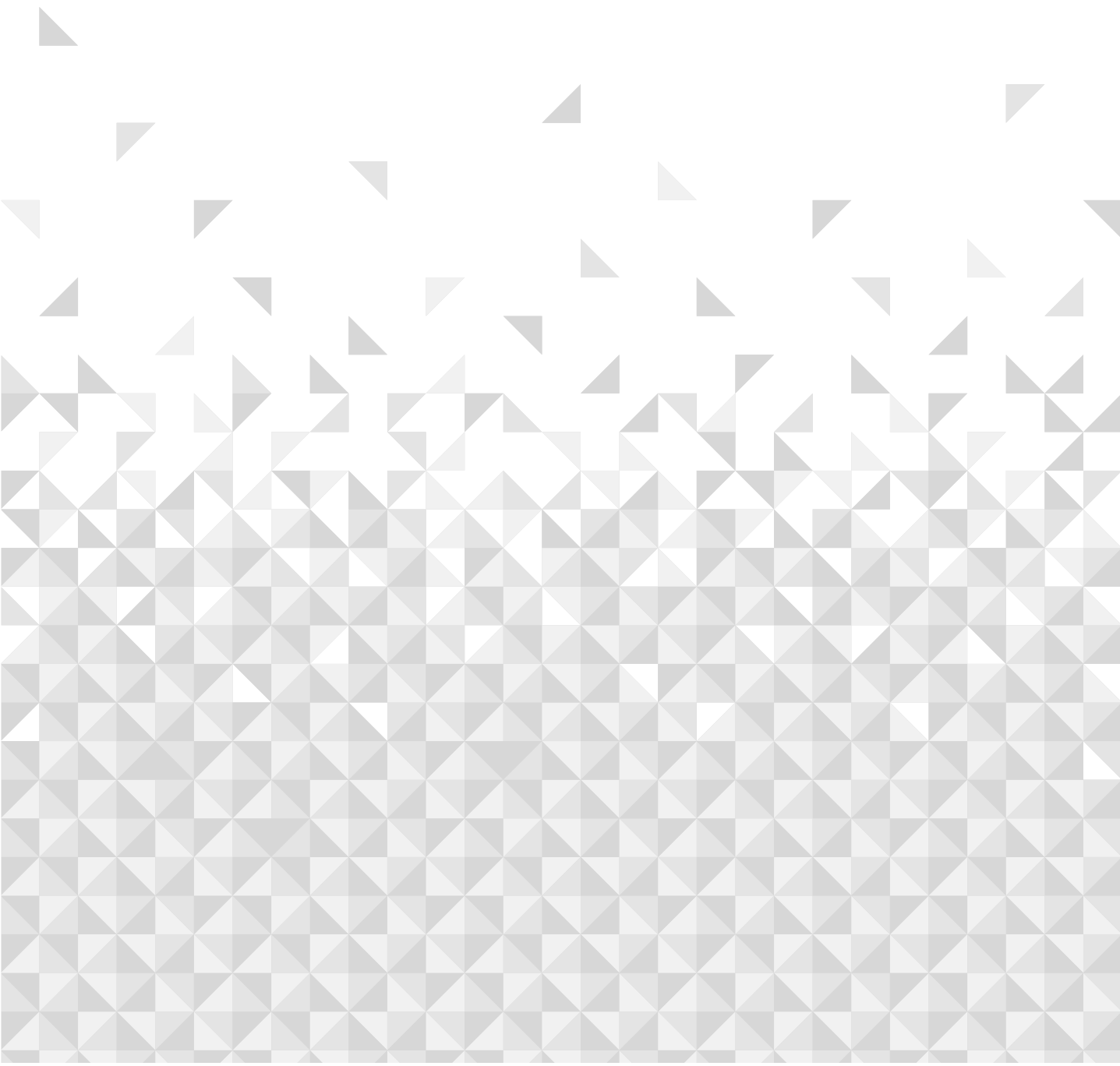

Other information

Helpful technical information

Specification

Digital Reception	Fully integrated digital terrestrial TV (DVB-T) (DVB-T2 compliant)
Number of Preset Channels	2 000
Channel Indicator	On Screen Display
RF Aerial Input	75 Ohm (unbalanced)
Operating Voltage	220-240V AC, 50Hz.
Audio	DTS HD DTS VIRTUAL:X
Audio Output Power (WRMS.) (10% THD)	2 x 12W
Power Consumption (W)	200W
Networked Standby Power Consumption (W)	< 2
Weight (Kg)	20
TV Dimensions DxLxH (with foot) (mm)	247 x 1462 x 912
TV Dimensions DxLxH (without foot) (mm)	48/75 x 1462 x 843
Display	65"
Operation temperature and operation humidity	0°C up to 40°C, 85% humidity max

Product Information

Energy Efficiency Class For Standard Dynamic Range	E
On-Mode Power Demand For Standard Dynamic Range	85 W
Energy Efficiency Class (HDR)	G
On-Mode Power Demand In High Dynamic Range (HDR)	129 W
Off-Mode Power Demand	N/A
Standby Mode Power Demand	0,5 W
Networked Standby Mode Power Demand	2 W
Contrast Ratio	1200:1
Screen Resolution	3840 x 2160 Pixels



Scan QR code for Product Information Sheet

If you require any technical guidance or find that your TV is not operating as intended, a simple solution can often be found in the **Help Menu**, or online at www.bush-support.co.uk. If you still require further assistance, call one of our experts on **0345 604 0105**, a **Bush enquiry line**.

Other information

Helpful technical information

Wireless LAN Transmitter Specifications

Frequency Ranges	Max Output Power
2400 - 2483.5 MHz (CH1 - CH13)	< 100 mW
5150 - 5250 MHz (CH36 - CH48)	< 200 mW
5250 - 5350 MHz (CH52 - CH64)	< 200 mW
5470 - 5725 MHz (CH100 - CH140)	< 200 mW

Country Restrictions

The Wireless LAN equipment is intended for home and office use in the UK & Ireland (and other countries following the relevant EU and/or UK directive) without any limitation except for the countries mentioned below).

Country	Restriction
Bulgaria	General authorisation required for outdoor use and public service
Italy	If used outside of own premises, general authorisation is required
Greece	Indoor use only for 5470 MHz to 5725 MHz band
Luxembourg	General authorisation required for network and service supply (not for spectrum)
Norway	Radio transmission is prohibited for the geographical area within a radius of 20 km from the centre of Ny-Ålesund
Russian Federation	Indoor use only
Israel	5 GHz band only for 5180 MHz-5320 MHz range

The requirements for any country may change at any time. It's recommended that user checks with local authorities for the current status of their national regulations for 5 GHz wireless LAN's.

Other information

Helpful technical information

Stand Installation & Wall Mounting

Assembling / Removing the stand

Preparations

Take out the stand(s) and the TV from the packing case and put the TV onto a work table with the screen panel down on a clean and soft cloth (blanket, etc.)

- Use a flat and firm table bigger than the TV.
- Do not hold the screen panel part.
- Make sure not to scratch or break the TV.

Assembling the stand

1. Place the stand(s) on the stand mounting pattern(s) on the rear side of the TV.

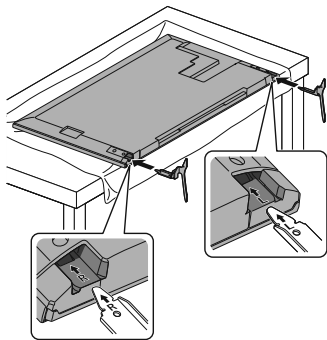

2. Insert the screws provided and tighten them gently until the stand is properly fitted.

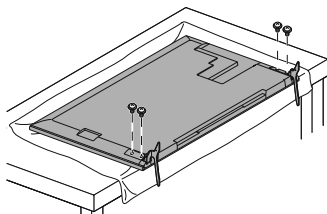

Removing the stand from the TV

Be sure to remove the stand in the following way when using the a wall mount bracket or repacking the TV.

- Put the TV onto a work table with the screen panel down on a clean and soft cloth. Leave the stand(s) protruding over the edge of the surface.
- Unscrew the screws that fix the stand(s).
- Remove the stand(s).

When using the wall mount bracket

Your TV is also prepared for a VESA-compliant wall mount bracket. If it is not supplied with your TV, contact your local dealer to purchase the recommended wall mount bracket.

Holes and measurements for wall mount bracket installation;

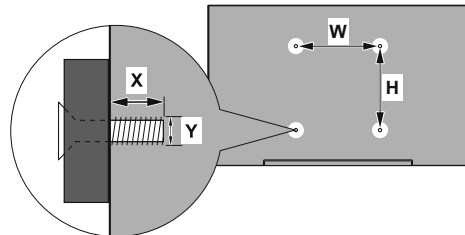

VESA WALL MOUNT MEASUREMENTS		
Hole Pattern Sizes (mm)	W	H
	400	200
Screw Sizes		
Length (X)	min. (mm)	10
	max. (mm)	13
Thread (Y)	M6	

If you require any technical guidance or find that your TV is not operating as intended, a simple solution can often be found in the **Help Menu**, or online at www.bush-support.co.uk. If you still require further assistance, call one of our experts on **0345 604 0105**, a **Bush enquiry line**.

Other information

Helpful technical information

This TV is a product of Vestel, which is not affiliated with Amazon.com, Inc. or any Amazon affiliate.

DVB-T functionality information

This DVB receiver is only suitable for use in the country which it was designed to be used in.

Although this DVB receiver conforms to the latest DVB specifications at the time of manufacture, we cannot guarantee compatibility with future DVB transmissions due to changes that may be implemented in broadcast signals and technologies.

Some digital TV functions may not be available in all countries.

We continually strive to improve our products; therefore, specifications may change without prior notice.

For advice on where to purchase accessories, please contact the store where you purchased your TV.

Functionality information

The content and services provided by third-party providers may be altered, suspended or discontinued at any time without notice.

Bush is not responsible for any of the content or services and does not warrant the availability of or access to such content or services.

For information on a particular service or on any content, please visit the service/content provider's website. If you have any questions concerning, or problems with, any content or services then please contact the relevant service/content provider directly. Bush is not responsible for providing customer service in relation to content or services and accepts no liability in this regard.

Product support 7

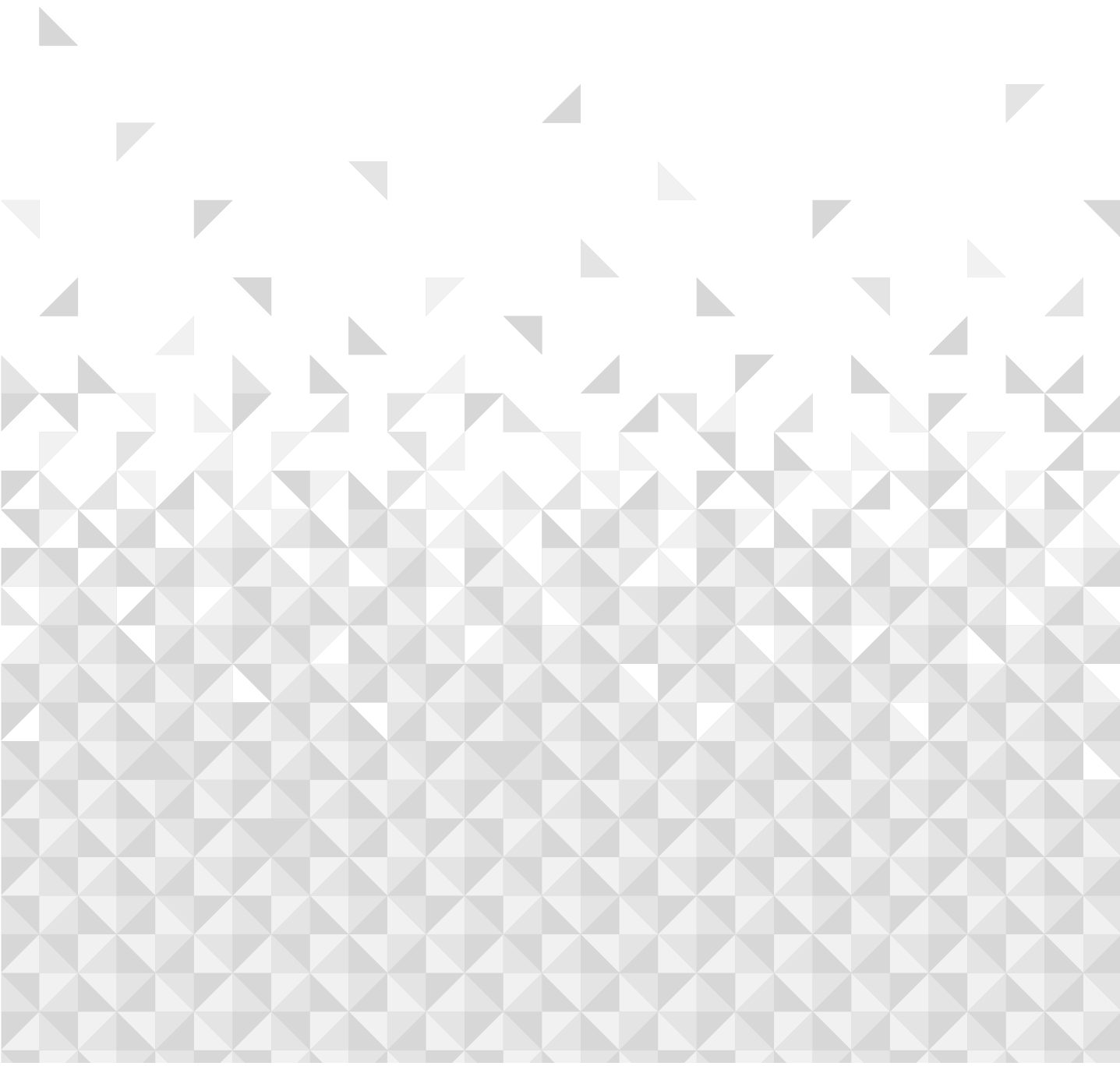

Product support

Help is always at hand

Help and assistance

If you require any technical guidance or find that your TV is not operating as intended, a simple solution can often be found in the **Help** menu or online at www.bush-support.co.uk.

If you still require further assistance, call one of our experts on **0345 604 0105 a Bush enquiry line***. To help give us give you a fast and efficient service please have the following information ready:

Model Ref.	<input type="text"/>	You can find these on the rating plate - a small information panel (usually a sticker or metal plate) on the rear of your TV
Serial number	<input type="text"/>	
Date of purchase	<input type="text"/>	This will be shown on your receipt

Local call rates applies*

Lines open 8am-7pm Monday to Saturday and 10am-4pm Sunday.

*Calls to **Bush enquiry lines** may attract a charge and set up fee from residential lines depending on your call plan/tariff. Mobile and other providers costs may vary. Refer to your residential line provider / mobile provider for pricing details. For security and training purposes, telephone calls to and from customer service centres may be recorded and monitored. Calls from Republic of Ireland will attract international call charges.

If you require any technical guidance or find that your TV is not operating as intended, a simple solution can often be found in the **Help Menu**, or online at www.bush-support.co.uk. If you still require further assistance, call one of our experts on **0345 604 0105 a Bush enquiry line**.

Product support

Help is always at hand

Disposal Information

[European Union]

These symbols indicate that the electrical and electronic equipment and the battery with this symbol should not be disposed of as general household waste at its end-of-life. Instead, the products should be handed over to the applicable collection points for the recycling of electrical and electronic equipment as well as batteries for proper treatment, recovery and recycling in accordance with your national legislation and the Directive 2012/19/EU and 2013/56/EU.

By disposing of these products correctly, you will help to conserve natural resources and will help to prevent potential negative effects on the environment and human health which could otherwise be caused by inappropriate waste handling of these products.

For more information about collection points and recycling of these products, please contact your local municipal office, your household waste disposal service or the shop where you purchased the TV.

Penalties may be applicable for incorrect disposal of this waste, in accordance with national legislation.

[Business users]

If you wish to dispose of this TV, please contact your supplier and check the terms and conditions of the purchase contract.

[Other Countries outside the European Union]

These symbols are only valid in the European Union.

Contact your local authority to learn about disposal and recycling.

The TV and packaging should be taken to your local collection point for recycling.

Some collection points accept products free of charge.

Note: The sign Pb below the symbol for batteries indicates that this battery contains lead.

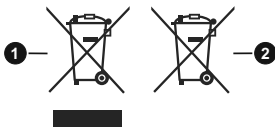

1. Products
2. Battery

If you require any technical guidance or find that your TV is not operating as intended, a simple solution can often be found in the **Help Menu**, or online at www.bush-support.co.uk. If you still require further assistance, call one of our experts on **0345 604 0105**, a **Bush enquiry line**.

Product support

Help is always at hand

BUSH

Call us now and activate your 12 month guarantee

Thank you for choosing Bush. Your new product is guaranteed against faults and breakdowns for 12 months. Don't forget to register it with us today so we can provide you with our best possible after-sales service and useful updates.

www.bushregistration.co.uk

FREEPHONE*

0800 597 8548

Lines are open 8am - 8pm, 365 days a year. *Calls may be recorded and monitored.

Your Bush Guarantee

This product is guaranteed for twelve months from the date of original purchase. Any defect that arises due to faulty materials or workmanship will be repaired free of charge (or if applicable the product will be replaced or the purchase price refunded) where possible during this period by the dealer from who your purchased the unit.

The guarantee is subject to the following provisions:

- The guarantee does not cover accidental damage, misuse, cabinet parts, knobs or consumable items.
- The product must be correctly installed and operated in accordance with the instructions contained in the manual.
- It must be used solely for domestic purposes. The guarantee will be rendered invalid if the product is re-sold or has been damaged by inexpert repair.
- Specifications are subject to change without notice.
- Bush disclaim any liability for loss or damage arising from the breakdown of the product.
- This guarantee is in addition to and does not diminish your statutory or legal rights.

Important Data Protection Information

If you provide us with information about another person, you confirm that they have appointed you to act for them, to consent to the processing of their personal data including sensitive personal data and that you have informed them of our identity and the purposes for which their personal data will be processed.

You are entitled to ask for a copy of the information we hold about you (for which we may charge a small fee) and to have any inaccuracies in your information corrected.

For quality control and training purposes, we may monitor or record your communications with us.

If your personal details change, if you change your mind about any of your marketing preferences or if you have any queries about how we use your information, please let us know by contacting our **Data Protection Officer, Domestic and General, Leicester House, 17 Leicester Street, Bedworth, Warwickshire CV12 8JP.**

Guarantor: Argos Limited - 489 - 499 Avebury Blvd. - Milton Keynes - MK9 2NW

Argos (N.I.) Ltd, Forestside Shopping Centre, Upper Galwally, Belfast, United Kingdom, BT8 6FX. Argos Distributors (Ireland) Limited, Unit 7, Ashbourne Retail Park, Ballybin Road, Ashbourne, County Meath. Ireland

If you require any technical guidance or find that your TV is not operating as intended, a simple solution can often be found in the **Help Menu**, or online at www.bush-support.co.uk. If you still require further assistance, call one of our experts on **0345 604 0105**, a **Bush enquiry line**.

BUSH | firetv

Contact:

www.bush-support.com

Helpline: 0345 604 0105



50619746

