

# YAWN



## AIR BED USER INSTRUCTIONS

**IMPORTANT:**  
When fully inflated **ALWAYS** turn the valve at pump  
to the off (middle) position to prevent deflation

# IMPORTANT SAFETY INSTRUCTIONS

- When fully inflated ALWAYS turn the valve at pump to the off (middle) position to prevent deflation
- Do not expose the electric pump to moisture.
- Inspect the power cord regularly. Do not use the airbed if the power cord or plug is damaged.
- Do not attempt to disassemble, repair, or service the pump. No serviceable parts are contained inside.
- Never run the pump for longer than 10 minutes at a time. Let the motor cool down for 5 minutes before using it again. Disconnect the plug when the pump is not in use.
- Do not block air intake during operation, this could damage the motor.
- Do not let children use the electric pump.
- Do not use hot air to fill the air bed.
- Do not over inflate the airbed. Stop inflating once the airbed is fully expanded and firm.
- This airbed is not a buoyancy aid. Do not use it on water.
- This airbed is not a lifebuoy or life saving device.
- Keep the airbed away from fire.
- This airbed is not a toy. Do not stand or jump on it. Use only as a mattress.
- Always have the flocced surface facing upright.
- Never hold the air inlet / outlet near your eyes or hair when the pump is running.
- Never let children play with the airbed.
- Make sure that the airbed is laid on a level surface free from stones and sharp objects. Bed may tip over on uneven surfaces.
- This airbed may be used by children 8 years and older, and by persons with reduced physical, sensory or mental capability or lack of experience and knowledge, provided they are supervised and have been given instructions concerning use of the product in a safe way, and understand the hazards involved.
- Avoid exposing your airbed to extreme temperature (hot or cold). In hot weather, the air will expand. You must let out some air to prevent the airbed from failing due to overpressure. In cold weather your airbed will lose some pressure due to the fact that the air will contract.

## PARTS

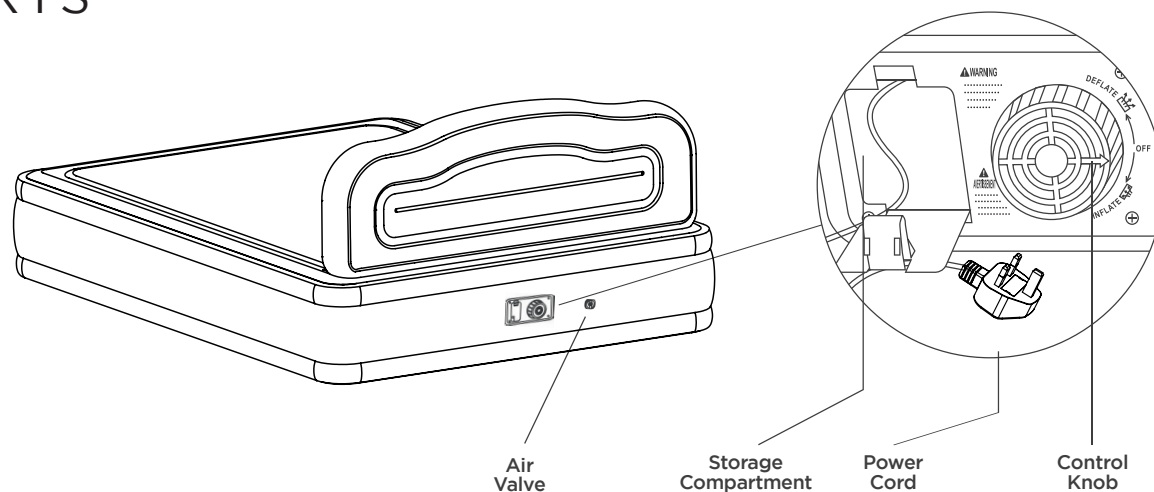

How to inflate using the built-in pump.

1. Lay the bed flat out on the floor free of obstructions or sharp objects. Ensure that the headboard section is on the top when laid out. Plug the mains lead into a wall socket.
2. Turn the control knob to ☒. Make sure the valve is closed.
3. When the airbed is sufficiently inflated (not hard), turn off the pump by turning the control knob to ●. In ordinary operating conditions, the airbed takes approximately 3 to 4 minutes to inflate. A high pitch whine of the pump will signal the bed is inflated to full (firmest) capacity. The airbed will not over inflate.
4. Pull out the mains plug and store it in its storage compartment.

How to deflate using the built-in pump.

1. Plug the mains lead into a wall socket.
2. Turn the control knob to ☒. In ordinary operating conditions, the airbed takes approximately 6 minutes to deflate.
3. When the airbed is empty, turn off the pump by turning the control knob to ● position (OFF).
4. Pull out the mains plug and store it in its storage compartment.

# MANUAL INFLATION AND DEFLATION

The airbed is pump compatible – it can be pumped manually when travelling or far away from a power source. It can be inflated with a hand pump, foot pump or bicycle pump as long as the pump fits the air valve opening. Don't use a compressor or any other mechanical pump. Do not over inflate the airbed.

1. Remove the cap from the air valve.
2. Connect a hand pump to the air valve.
3. Inflate the bed manually. Do not over inflate the airbed.
4. Replace the air valve cap.
5. The air valve has 3 settings; OPEN, INLET ONLY and SEALED. Use the INLET ONLY setting to inflate the bed in small increments to adjust the firmness of the bed.
6. For manual deflation, leave the air valve in the OPEN setting.

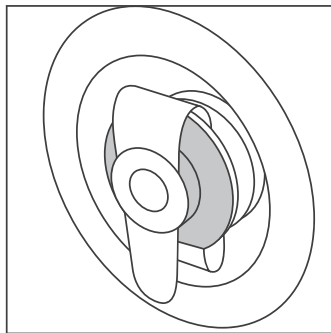

Sealed

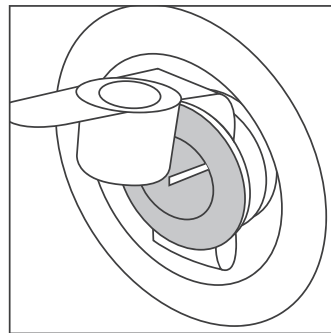

Inlet only

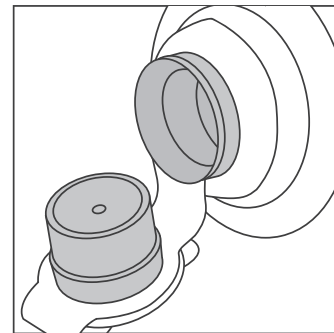

Open

# MAINTENANCE AND STORAGE

- Wipe clean only with a damp cloth. DO NOT use strong detergents.
- Ensure the airbed is completely DEFLATED and DRY before storage.
- Store in a cool, dry place.
- Your airbed should be stored with the valve closed.
- Keep sharp objects away from the airbed.
- In case of a puncture, a repair patch has been included. Please follow repair instructions carefully.

# FOLDING INSTRUCTIONS

If single bed start from step 3.

1. Ensure bed is flat and fully deflated with headboard folded onto bed.
2. Fold over side by one quarter.
3. Fold over again by one quarter.
4. Fold opposite side to the centre.
5. Fold again.
6. Fold 3 times.
7. Put into bag.

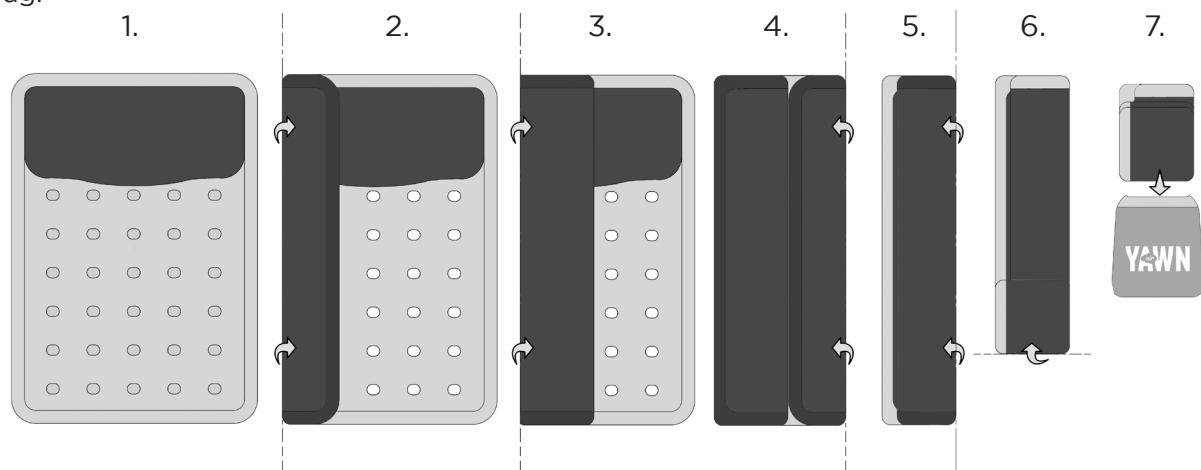

Visit [www.highstreettv.co.uk](http://www.highstreettv.co.uk)  
to purchase your bespoke Yawn Air Bed Fitted Sheet.



**[www.highstreettv.com](http://www.highstreettv.com)**

Distributed by:  
High Street TV,  
PO Box 724,  
Altrincham,  
WA15 5BJ



Made in China.  
Please read all instructions carefully and retain for future reference.  
Model numbers: YAB01, YAB02, YAB03.

Version 5 06/18