



- EN** Instruction manual
- NL** Gebruiksaanwijzing
- FR** Mode d'emploi
- DE** Bedienungsanleitung
- ES** Manual de usuario
- PT** Manual de utilizador
- PL** Instrukcja obsługi
- IT** Manuale utente
- SV** Bruksanvisning
- CS** Návod na použití
- SK** Návod na použitie
- RU** Руководство по эксплуатации



Robot Vacuum Deluxe

01.339000.01.001

 **PRINCESS**

SAFETY

- By ignoring the safety instructions the manufacturer can not be held responsible for any damages.
- If the supply cord is damaged, it must be replaced by the manufacturer, its service agent or similarly qualified persons in order to avoid a hazard.
- Only authorized technicians can disassemble the product. Users are not allowed to disassemble, repair or modify the product. Otherwise it may possibly cause electric shock, malfunction and lead to injuries.
- Never move the appliance by pulling the cord and make sure the cord can not become entangled.
- The appliance must be placed on a stable, level surface.
- The user must not leave the device unattended while it is connected to the power supply.
- This appliance is only to be used for household purposes and only for the purpose it is made for.
- Do not use this product in wet or moist environment (any environment with liquid), e.g. bathroom or laundry. Do not wash this product.
- This appliance shall not be used by children younger than 8 years old. This appliance can be used by children aged 8 years or older and persons with reduced physical, sensory or mental capabilities or lack of experience and knowledge if they have been given supervision or instruction concerning use of the appliance in a safe way and understand the hazards involved. Keep the appliance and its cord out of reach of children younger than 8 years old. Cleaning and maintenance shall not be performed by children.
- To protect yourself against an electric shock, do not immerse the cord, plug or appliance in water or any other liquid
- The plug must be removed from the socket-outlet before cleaning or maintaining the appliance.
- Children shall not play with the appliance.
- Only use the original battery and power adapter of the product for charging. Using an unmatched adapter may cause electric shock, fire or product damage.
- Do not touch power cord, plug, adapter or any other metal part of machine with wet hands.
- Do not have the product covered or wrapped while using. Do not have curtain, any material that is easily twisted together, or part of user's body stuck in the wheels.
- Make sure this product is not close to cigarette ends, lighters, matches or any flammables.
- Do not sit or put heavy or sharp objects on machine. Beware of children or pets while the product is in operation.
- Before use, clean floor environment (remove all fragile objects, and all objects that may get caught in the product, such as cords, clothing, papers, loose cables); Lift curtains and drapes off the floor to avoid any possible accidents.
- Never use the product to clean combustible or highly volatile liquids, such as gasoline.
- Do not place this product where it's easy to drop off (tables, chairs, etc.).
- Turn off the power switch during product transportation or when you don't need to use the product for a long time. Battery leakage may cause fire, injury or pollution to the

environment.

- Before charging, check whether adapter and outlet are properly connected.
- To avoid tripping, user should inform all the people in the house when this product is working.
- When dust bin is full, empty it before use.
- Use this product in temperature between 0°C to 40°C.
- Do not use this product in a high-temperature environment or under intense sunlight directly for a long time.
- The battery must be removed from the product before it's discarded.
- The battery should be disposed of properly for safety's sake.
- The adapter must be removed from the socket-outlet before cleaning, maintaining the appliance or removing the battery.
- Do not put screwdriver or other sharp objects into air outlet, this will damage the product.

PARTS DESCRIPTION

1. Main body
2. Charging station
3. Power adapter
4. Hepa filter
5. Set of left and right brushes
6. Suction kit
7. Power switch
8. Touch buttons
9. LED display
10. Roller brush kit
11. Wheels
12. Charging socket
13. Auto charging pad

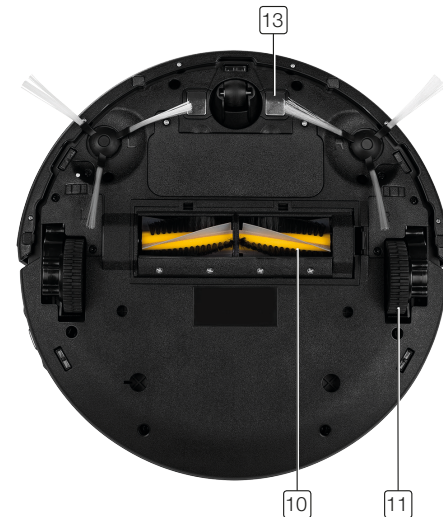

LED DISPLAY

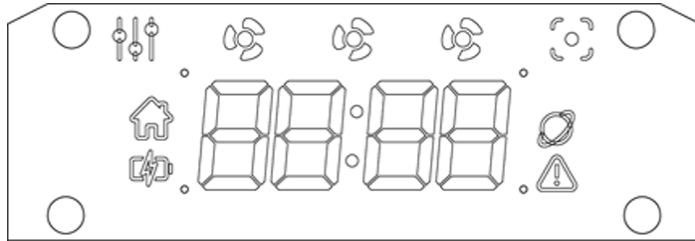

	Other cleaning modes except for spot, normal, quiet and max modes
	Quiet mode
	Normal mode
	Max mode
	Spot mode
	Auto-charge indicator
	Power indicator
	Cloud connection indicator
	Error indicator

Touch buttons

	<ul style="list-style-type: none"> Tap this button to wake the Cleaner from sleep mode. Hold this button for more than 3 seconds to enter sleep mode. Press this button to start cleaning. If the Cleaner is busy cleaning, tapping this button stops it. Repeatedly tap this button to cycle through the cleaning modes: Normal, Max and Quiet. The Cleaner will start cleaning 3 seconds after selecting a cleaning program.
	<ul style="list-style-type: none"> Press this button to start docking. The Cleaner will automatically start looking for its dock. Press and hold this button until the display shows a “pulse” animation. When this animation is visible, the Cleaner can be connected to Wi-Fi with the App.
	<ul style="list-style-type: none"> Tap this button to enter spot cleaning mode (Cleaner cleans an area of 2x2 meters, with higher suction power and lower speed)
	<ul style="list-style-type: none"> Hard-press this button to open / close the top cover, and take out the dust bin.

PRODUCT FEATURES

This is an automatic cleaning robot which is well equipped with not only cleaning programs, double side brushes and strong suction power, but also with interchangeable roller brush kits and vacuum suction kits. The machine can automatically identify if the kit installed is a roller brush or suction kit, then it will decide the working mode by itself, which makes the machine clean more efficiently. Suction power of this product is strong enough to ensure that even tiny dust on the floor will be cleaned thoroughly! This product is able to automatically adjust its suction power when different floor environments are detected. This ability not only makes cleaning more efficient, but also helps to save power (up to 30%).

BEFORE FIRST USE

- Take the appliance and accessories out the box. Remove the stickers, protective foil or plastic from the device.
- Install the Application called “HomeWizard Cleaner” from the App Store. The App will show up as “Cleaner” when installed.

Battery Charging

- Place charging station against the wall and remove obstacles within 1 meter at two sides and 2 meters ahead.

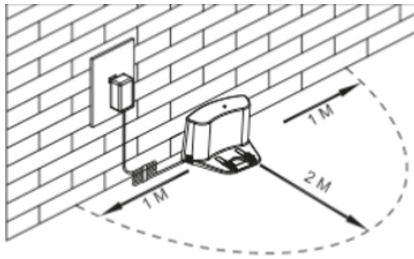

- If the Cleaner is shut down, turn on its power switch at the right side of Cleaner before charging.
- Charge the Cleaner in either of the following ways:
 - a. Plug the adapter into the Cleaner and plug the other end into the power socket, as shown in Fig a.
 - b. Press  on Cleaner to direct the Cleaner to charging station for recharging, as shown in Fig b.

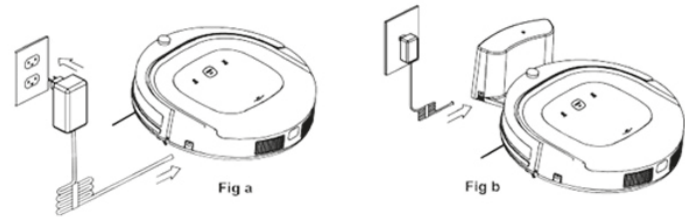



- Make sure the power switch of Cleaner is turned on while charging. Otherwise, it will show an error on LED display and will not charge.
- When the Cleaner is charging, the power indicator will blink.
- Once charging is completed, the power indicator will be on and stop blinking.
- In standby status, the Cleaner will play a sound when battery power is low.
- During working, the Cleaner will return to charging station automatically when battery power is low.

Tips to extend battery life:

- Before first use, charge the Cleaner for 12 hours.
- Charge the Cleaner as soon as battery power is low.
- During cleaning, Cleaner will return to charging station automatically when it is done cleaning or when the battery is low.
- If the Cleaner is not to be used for more than 3 months, charge the battery in the Cleaner for 12 hours, turn off the power of the Cleaner, remove the battery from the Cleaner and store it in a cool, dry place.

USE

Starting up

- Power on the Cleaner by turning on the power switch on the right side of machine. Tap the  button on the top to wake up the Cleaner.
- In standby mode, tap  button on the top to start cleaning.
- Note: If Cleaner is in sleep mode, long-press the  button on the top to wake up the Cleaner from sleep mode, then tap button again, to start cleaning.

Standby:

- When Cleaner is cleaning, tap  button on the top to stop the Cleaner and enter standby mode.

Sleep Mode:

- Long-press  button on the top for 3 seconds, Cleaner will enter sleep mode.
- Cleaner will automatically enter sleep mode if no command is received for more than 60 seconds.

Power off:

- In standby mode, turn off the power switch at the right side of Cleaner.
- In sleep mode, the Cleaner will automatically power off if there is no operation for more than 5 minutes, it can only be woken up by long-pressing clean/stop button on the top for 3 seconds.
- Note: if the Cleaner is not in use for a long time, please turn the power switch off.

VARIOUS CLEANING MODES

Normal cleaning mode

- The Cleaner can clean a room automatically.
- Turn on Cleaner's power switch, tap "CLEAN" button on the top or press the "CLEAN" button in the App.
- Cleaner will start navigating and cleaning automatically.
- The Cleaner's display will show 2 fans.

Edge cleaning mode

- In this mode, the Cleaner will clean along the wall or obstacles.
- Note: You can start "Edge" cleaning from the App.

Scheduling mode

- After being scheduled via the App, the Cleaner will leave its charging station and start cleaning at the scheduled time.

Max mode

- Tap the "CLEAN" button on the top two times.
- Within 3 seconds, the Cleaner will start cleaning with increased suction power and a lower speed, thoroughly cleaning your room.
- The Cleaner's display will show 3 fans.

Quiet Mode

- Tap the "CLEAN" button on the top three times. Within 3 seconds, the Cleaner will start cleaning with no suction, only lightly sweeping dirt off the ground and do so quietly.
- The Cleaner's display will show 1 fan.

Spot Cleaning

- Tap "SPOT" on the top or "SPOT" button in the App to start a spot cleaning. The Cleaner will clean an area of 2x2 meters, suction power will be increased and driving speed will slow down, Thoroughly cleaning the 2x2 area.



Deep cleaning

- The Cleaner will cover your room twice to ensure that it reached every corner.
- Note: You can start the “Deep cleaning” program from the App.

Random cleaning

- The Cleaner will clean in a random pattern, instead of a smart combination of zig-zag and edges.
- Note: You can start the “Random” program from the App.

MAP NAVIGATION FUNCTION

- Before use, place the Cleaner flat on the floor.
- Turn on power switch, next, tap  button on the top. The display panel shows a rotating loading animation and a “startup” sound is played.
- After turning on, the display is off (depending on the connection status, it may show the “Cloud connection” icon). Then tap  button on the top one more time to start cleaning.
- The Cleaner will return to docking station automatically after cleaning if the docking station is powered on. If no docking station detected, the Cleaner will return near its starting point after cleaning.

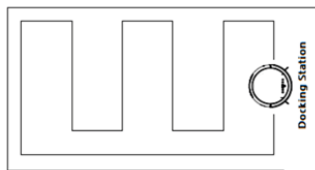
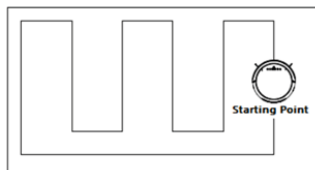

SUCTION KIT AND ROLLER BRUSH KIT

- Suction kit and roller brush kit can be switched out at the bottom of your Cleaner (as shown in below figure).

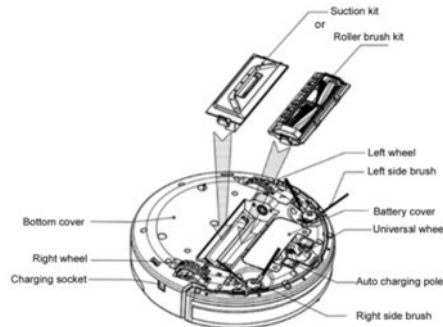

CLEANING AND MAINTENANCE

Cleaning Side Brushes

- Check the side brush when it gets dirty and replace it if it's damaged. The maximum lifespan for the side brushes is 12 months.
- Note: Before replacing side brushes, please pay attention to the “left” and “right” mark (“L” / “R”) on the side brushes, which match with the “L” / “R” mark on the bottom of the Cleaner.

Cleaning Dust Bin and Filters

- Empty and clean dust bin after each use following the steps as shown in the below figures:

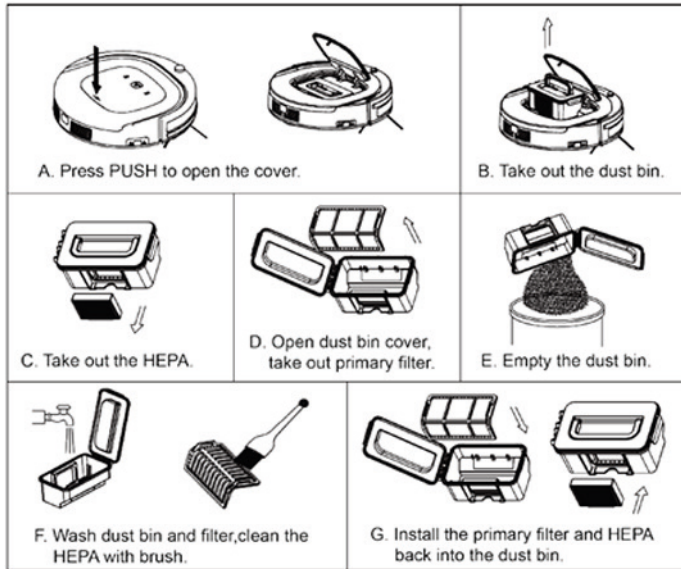

Note:

- Wash primary filter after 15-30 days of use. Maximum life span for filters is 24 months.
- Re-install the HEPA and primary filter after they're fully dry.
- HEPA and primary filter could be replaced if needed.
- Do not expose the filters to intense sunlight directly.

Cleaning Sensors and Wheels

- Slightly wipe all the sensors and wheels, as marked in below figure, with soft cleaning cloth or tool.

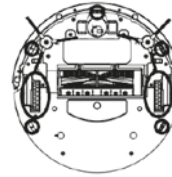

Cleaning Charging Poles

- Clean the charging poles, as marked in below figure, with soft cleaning cloth or tool.

Cleaning Suction Passage and Dust Sensor

- Take out the suction kit from Cleaner, then clean the suction passage and dust sensor, as marked in below figure, with soft cleaning cloth or tool.

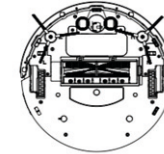

- Note: Keep the Cleaner and sensors dry and avoid contact with liquids.

Cleaning Roller Brush Kit

- Take out the roller brush kit from Cleaner, remove the roller brush, then clean it and its cover-plate & holder, as shown in the below figure, with soft cleaning cloth or tool. (the roller brush can be washed by water).

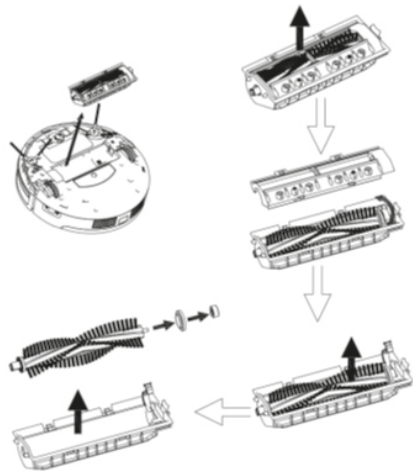

- Note: Please re-install the roller brush in the original order of disassembly after it's fully dry.

How to open the roller brush kit cover

- Rotate the lid of the roller brush so that it is facing you.



- With both thumbs holding the lid of the roller brush, push it up.

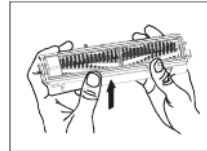

- The cover of roller brush is opened, like illustrated in the picture below.

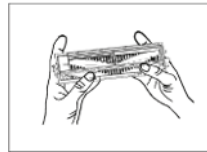

TROUBLESHOOTING

Error code for sensors

Error Code	Cause	Solution
E1	Dustbin box not installed	Install dustbin box properly
E2	Power switch off while charging	Turn on power switch
E3	Lower battery or auto charging failed	Charge the Cleaner manually
E11	Left stair detect sensor problem	Clean left stair detect sensor or replace it
E12	Right stair detect sensor problem	Clean right stair detect sensor or replace it
E13	Front stair detect sensor problem	Clean front stair detect sensor or replace it
E21	Left wheel off ground	Put the machine in a safe place
E22	Right wheel off ground	Put the machine in a safe place
E23	Front Wheel off ground	Put the machine in a safe place
E31	Front bumper left side micro switch stuck or broke	Check if it was stuck, or replace it

Error Code	Cause	Solution
E32	Front bumper right side micro switch stuck or broke	Check if it was stuck, or replace it
E33	Front bumper straight ahead micro switch stuck or broke	Check if it was stuck, or replace it
E41	Left wheel overloaded	Check if it was stuck, or replace it
E42	Right wheel overloaded	Check if it was stuck, or replace it
E43	Left side brush overloaded	Check if it was stuck, or replace it
E44	Right side brush overloaded	Check if it was stuck, or replace it
E45	Fan motor overloaded	Check if fan is pressed, and clean dust bin
E46	Rolling brush overloaded	Check if it was stuck, clean it or replace it
EXX9	Left anti-drop sensor detects cliff, front bumper right infrared sensor detects obstacle	Clean front bumper sensor lens and bottom anti-drop sensor lens
EXXA	Front anti-drop sensor detects cliff, front bumper right infrared sensor detects obstacle	
EXXB	Left and front anti-drop sensors detect cliff, front bumper right infrared sensor detects obstacle	
EXXC	Right anti-drop sensor detects cliff, front bumper right infrared sensor detects obstacle	
EXXD	Left and right anti-drop sensors detect cliff, front bumper right infrared sensor detects obstacle	
EXXE	Right and front anti-drop sensors detect cliff, front bumper right infrared sensors detect obstacle	
EXXF	Front, left and right anti-drop sensors detect cliff, front bumper right infrared sensors detects obstacle	

Error Code	Cause	Solution
EX1X	Front bumper left infrared sensor detects obstacle	Clean front bumper sensor lens
EX2X	Front bumper middle infrared sensor detects obstacle	
EX3X	Front bumper left and middle infrared sensors detect obstacle	
EX4X	Front bumper right infrared sensor detects obstacle	
EX5X	Front bumper left and right infrared sensors detect obstacle	
EX6X	Front bumper middle and right infrared sensors detect obstacle	
EX7X	Front bumper left, middle and right infrared sensors detect obstacle	
EX8X	Front bumper wall detection infrared sensor detects obstacle	
EX9X	Front bumper wall detection sensor and left infrared sensor detect obstacle	
EXAX	Front bumper wall detection sensor and middle infrared sensor detect obstacle	
EXBX	Front bumper wall detection sensor, left and middle infrared sensor detect obstacle	
EXCX	Front bumper wall detection sensors, right infrared sensor detect obstacle	
EXDX	Front bumper wall detection sensors, left and right infrared sensor detect obstacle	
EXEX	Front bumper wall detection sensors, right and middle infrared sensors detect obstacle	
EXFX	Front bumper wall detection sensors, left, right and middle infrared sensors detect obstacle	

Error codes for motor

Error code	Cause	Solution
L01X	Fan overloaded	Check if fan is pressed, and clean dust bin
L0X1	Left wheel overloaded	Check if it is stuck or wired by obstacles
L0X2	Right wheel overloaded	
L0X3	Left and right wheels overloaded	
L0X4	Left side brush overloaded	
L0X5	Left wheel and left side brush overloaded	
L0X6	Right wheel and left side brush overloaded	
L0X7	Left and right wheels, left side brush overloaded	
L0X8	Right side brush overloaded	
L0X9	Left wheel and right side brush overloaded	
L0XA	Right wheel and right side brush overloaded	
L0XB	Left and right wheels, right side brush overloaded	
L0XC	Left and right side brushes overloaded	
L0XD	Left wheel, left and right side brushes overloaded	
L0XE	Right wheel, left and right side brushes overloaded	
L0XF	Left and right wheels, left and right side brushes overloaded	
L02X	Roller brush overloaded	

Panel display codes

LO	Low battery
11:11	Charging
FULL	Charging completed
CONN	WIFI connecting
FAIL	WIFI connection failed
SUCC	WIFI disconnect succeed

Note:

- The App will show detailed error information.
- There is no problem for the Cleaner when it displays L000.
- X marks the spot where number or letter might appear on the display for different faults.
- If Cleaner displays E001 or E004, please directly find the relative solution referred in troubleshooting.
- If Cleaner displays EC07, please find ECXX and EXXX for relative solution referred in troubleshooting.
- Likewise, if Cleaner displays EE91, please find EXX1, EEXX and EX9X for relative solution referred in troubleshooting.
- If above solution does not work, please try below:
 - a) Reset the Cleaner by switching off the machine, then turn it on and check again.
 - b) If it still does not work after reset, contact the after sales.

Warnings about battery



You must not remove (or attempt to remove) the battery incorporated in this product on your own. To replace the battery, you must contact your service provider or an independent qualified professional.

WARNING FOR YOUR OWN SAFETY, DO NOT ATTEMPT TO REMOVE THE BATTERY ON YOUR OWN OR DISPOSE OF IT IN FIRE. DO NOT DISASSEMBLE, CRUSH OR PUNCTURE THE BATTERY.

PRODUCT SPECIFICATIONS

Classification	Item	Detail
Mechanical Specifications	Diameter	350mm
	Height	88mm
	Weight	3.5kg
Electrical Specifications	Charger rating output	24V, 600mA
	Battery specifications	2150mAh rechargeable lithium
Functional Specifications	Dust bin capacity	0,5L
	Charging Type	Auto Charging/ Manual Charging
	Cleaning Mode	Auto, Deep clean, Edge, Max, Random, Spot, Quiet
	Charging Time	About 240~300 minutes
	Cleaning Time	90 minutes at maximum
	Frequency	Only 2.4Ghz, it will not work on 5Ghz
Button type of main body		Touch buttons + LED display



[Service Website](#)

Jules Verneweg 87 | 5015 BH Tilburg | The Netherlands | service.princess.info