

BUSH *Classic*

Instruction manual

TT-1862



You'll soon be enjoying your new Retro Turntable.

It all begins here, with your instructions. Don't worry, there's nothing too technical coming up. Just simple, step-by-step guidance to get you up and running quickly. Sound good? Then let's get started.

Help and Guidance

We're here to help you get the most from your Retro Turntable. Should you require any guidance, a simple solution can often be found online at:

www.bush-support.com

If you still require further assistance, call one of our experts on 0345 600 3021.

Contents

1 Safety information		4 Other information	
General safety information	6	Technical specification	24
Power source	6	5 Product support	
Heat sources and flames	6	Troubleshooting	28
Ventilation	7	Disposal	30
Care and cleaning	7	Declaration of Conformance	30
2 Getting to know your Retro Turntable		Your Bush Guarantee	31
Positioning the Retro Turntable	10		
Setting up	10		
Set the clock	11		
Your Retro Turntable	12		
3 Using your Retro Turntable			
Power on	16		
Standby mode	16		
Changing the source (mode)	16		
Adjusting the volume	16		
Using headphones	16		
Phono/Turntable mode	16		
Auto Stop On/Off	16		
Changing the Turntable speed (RPM)	16		
Playing a record	17		
CD Mode	17		
Play a CD	17		
CD controls	17		
Repeat and Random modes	18		
Programmed play mode	18		
FM Radio mode	18		
Tuning to an FM station	19		
Storing an FM station preset	19		
Tune to an FM station preset	19		
Using Bluetooth mode	19		
Controlling a paired Bluetooth device	20		
Aux in mode	20		

If you require any technical guidance or find that your product is not operating as intended, a simple solution can often be found in the **Troubleshooting** section of these instructions,

or online at www.bush-support.com If you still require further assistance, call one of our experts on **0345 600 3021**.

Safety information 1

This page is left intentionally blank

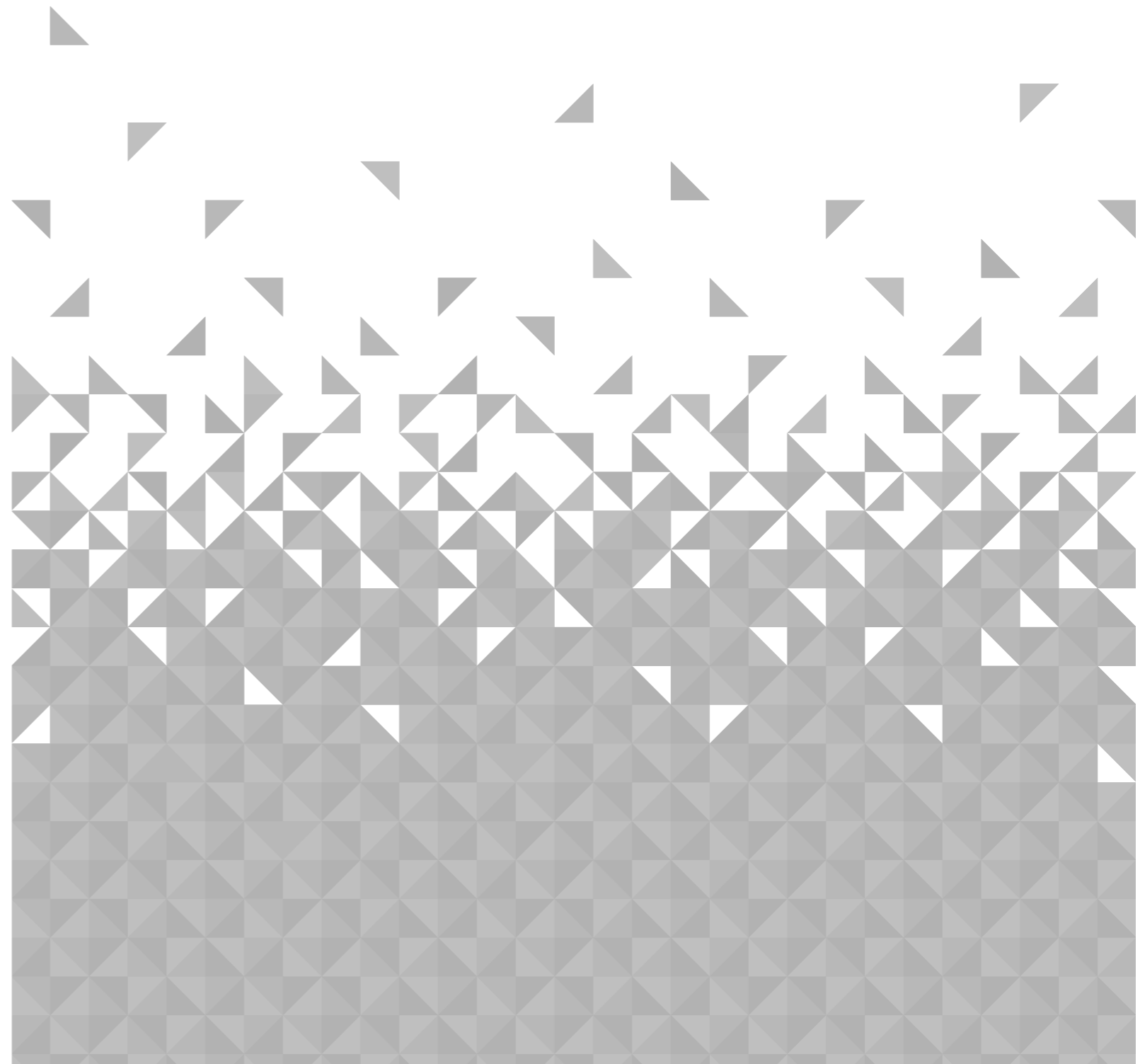



Safety information

Important - Please read these instructions fully before installing or operating

General safety information

- Keep the product and all its parts out of reach of small children.
- This product is not intended for use by persons (including children) with reduced physical, sensory or mental capabilities, or lack of experience and knowledge, unless they have been given supervision or instruction concerning the use of the appliance by a person responsible for their safety.
- Do NOT place foreign objects into the CD compartment.



CAUTION

Never touch or look into the optical lens within the CD compartment.



This is a CLASS-1 laser product.

Use of controls or adjustments other than those specified herein, may result in hazardous laser light beam exposure. Do NOT open the cover and do NOT attempt to repair it yourself. Refer servicing to qualified personnel. This product does not contain any user serviceable parts. Unauthorised handling of the device may damage it and will void your warranty.



CAUTION

To avoid possible hearing damage, do not listen to this Retro turntable at high volume levels for long periods of time. Always keep the volume within reasonable limits.

Power source

- Only use the power supply that came with the product. Using an unauthorised power supply will invalidate your guarantee and may irreversibly damage the product.
- Disconnect your Retro Turntable from the mains power supply during thunderstorms.
- Always check that you have completely switched off your Retro Turntable, before you change or disconnect the power supply.

- Where the mains power plug or an appliance coupler is used as the disconnect device, the disconnect device shall remain readily operable.
- The power socket must be within easy reach.
- In order to avoid electric shock, do not bend, stretch or pull the power supply cable.
- Switch the Retro Turntable off at the mains power socket and unplug it if you are leaving it unattended for a long period of time (holidays etc).
- **Do not** attempt to open the product. This product does not contain any user serviceable parts. Unauthorised handling of the product may damage it and will void your warranty.

Moisture and water

To reduce the risk of fire or electric shock:

- **Do not** use this product near water or moisture.
- **Do not** use this product near a bath or sink, near a swimming pool or anywhere else that water or moisture is present.
- **Do not** place objects filled with water, such as a vase, on or near the product.
- Keep it dry. Avoid exposure to precipitation, humidity and liquids which could all affect the product circuitry.

Heat sources and flames

- **Do not** leave this product in high temperatures as electronic devices and plastic parts may warp in heat.
- Keep it away from bright sunlight or heat sources, such as a radiator.
- Never place any type of candle or naked flame on top of, or near the product.



Safety information

Important - Please read these instructions fully before installing or operating

Ventilation

- **Do not** install this product in a confined space.
- Allow adequate ventilation to prevent heat build-up.
- **Do not** block or cover slots, holes or openings on the product by placing on soft furnishings such as carpets, rugs or beds as these are provided for functionality and/or ventilation to ensure safe operation of the product.
- For indoor use only.

Care and cleaning

- All care and cleaning operations should be carried out with the Retro Turntable unplugged from the mains power.
- Occasionally wipe the cabinet with a lint free cloth.
- Never clean the unit with liquids or solvents.

Getting to know your Retro Turntable

2

This page is left intentionally blank

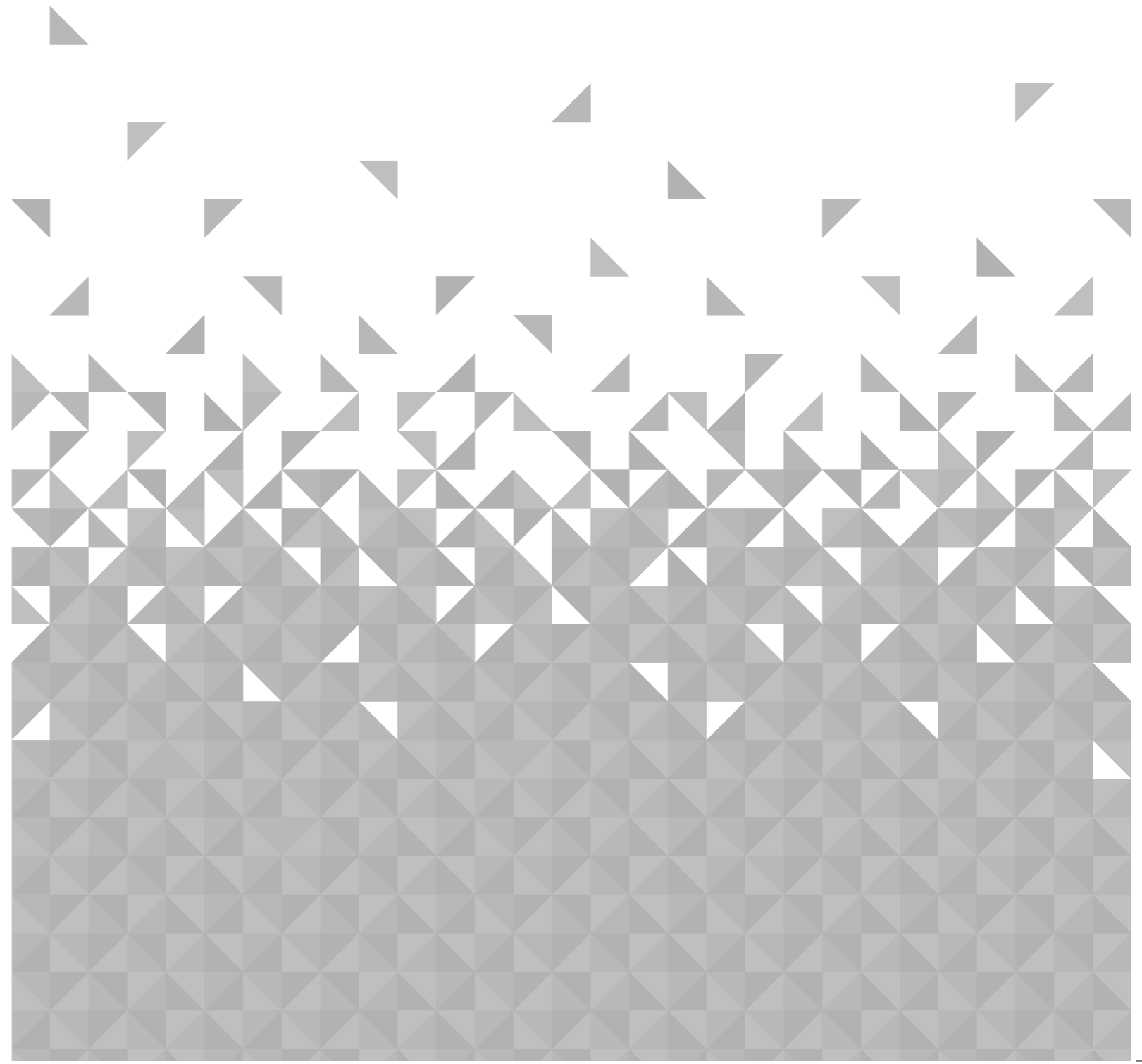

Getting to know your Retro Turntable

You'll be up and running in no time

Ready? Let's begin.

Please read these instructions carefully. They contain important information which will help you get the best from your Retro Turntable and ensure safe and correct installation and operation.

If you require any further assistance, our technical experts are happy to help. For full details, refer to the product support section at the end of these instructions.

Included with your Retro Turntable

1. 1 x felt turntable mat (already on the Turntable)
2. 1 x spindle adapter
3. 2 x stereo speakers with an RCA connection

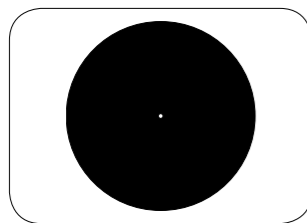

Felt turntable mat

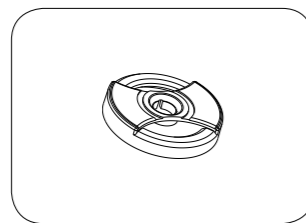

Spindle adapter

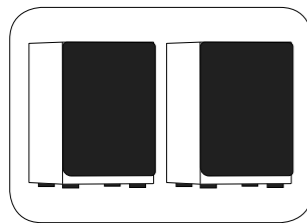

Stereo speakers

Positioning the Retro Turntable

It is important that you consider carefully in advance where your Retro Turntable and speakers will be situated. If you place the Retro Turntable on the same surface and very close to the speakers, the sound quality can be affected by the airborne movements coming from the speakers and from any vibrations from the surface on which they have been placed.

If at all possible, it is recommended that you leave a space of approximately 40cm between each speaker

and the Retro Turntable and that the surface on which you have placed the Retro Turntable and speakers, does not suffer from too much vibration, which can then be transmitted up into the Retro Turntable. Please make sure that:

- the Retro Turntable and speakers are on a flat and stable surface, which does not suffer from too much vibration. If you can, place the speakers on a different surface to the Retro Turntable.
- it is at least 1 metre away from other electrical appliances to avoid interference.
- it is within 1.4 metres of a power socket. Please ensure that the mains power lead and speaker wires are not a trip hazard.
- it is where it will be in range of the connected or 'paired' bluetooth device (e.g. iPod/ iPhone/iPad/ Android/other phone/Computer), which is about 10 metres or less (33 feet or less) in line of sight.
- you do not place your Retro Turntable or speakers directly onto antique or polished surfaces.

Setting up





1. Remove any product packaging materials, including any tape or foam that has been used to protect the product during transportation.
2. Connect the speakers to the Left and Right speaker sockets on the back of the Retro Turntable. Please note that the speaker cable with the red RCA plug should be connected to the red RCA socket and the speaker cable with the white RCA plug should be connected to the white RCA socket.
3. Fully extend the wire radio aerial on the back of the Retro Turntable to receive the best possible FM radio reception and sound quality.
4. Plug the mains power plug into the mains power wall socket and switch on. Your Retro Turntable will now be in Standby mode.
5. We recommend that you now set the clock.

Getting to know your Retro Turntable

You'll be up and running in no time

Set the clock

In standby mode:

1. Long press the  Stop button. 24H is displayed and the 24 digits will flash.
2. Short press the Tune/Skip buttons to choose between a 12 or 24 hour clock display and short press the  stop button to confirm.
3. A '0' will now flash in the display. Short press the Tune/Skip buttons to display the correct hour and then short press the  stop button to confirm.
4. The minute digits will then flash in the display. Short press the Tune/Skip buttons to display the correct minutes and then short press the  stop button to confirm.
5. Your clock is now set and will be displayed in Standby mode.

Getting to know your Retro Turntable

You'll be up and running in no time

Your Retro Turntable

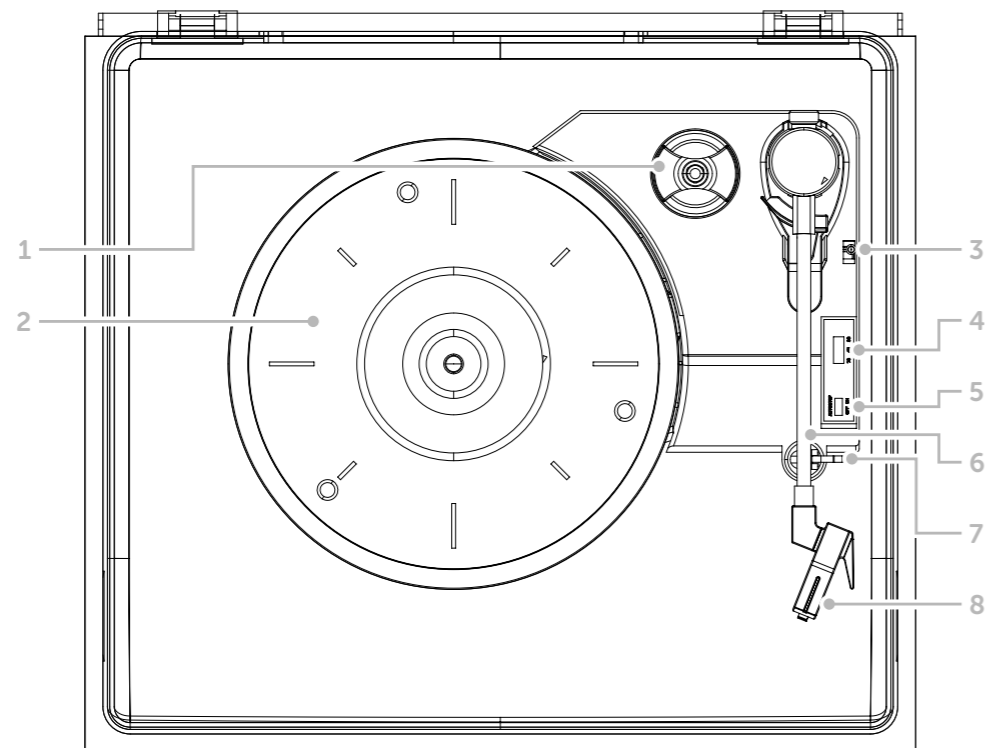

- | | |
|--|-------------------------------|
| 1. Spindle adapter. | 5. Turntable auto stop on/off |
| 2. Turntable platter with turntable mat (included) | 6. Tone arm |
| 3. Tone arm lever | 7. Tone arm clip |
| 4. 33/45/78 RPM turntable speed selection | 8. Stylus and stylus cover |

Getting to know your Retro Turntable

You'll be up and running in no time

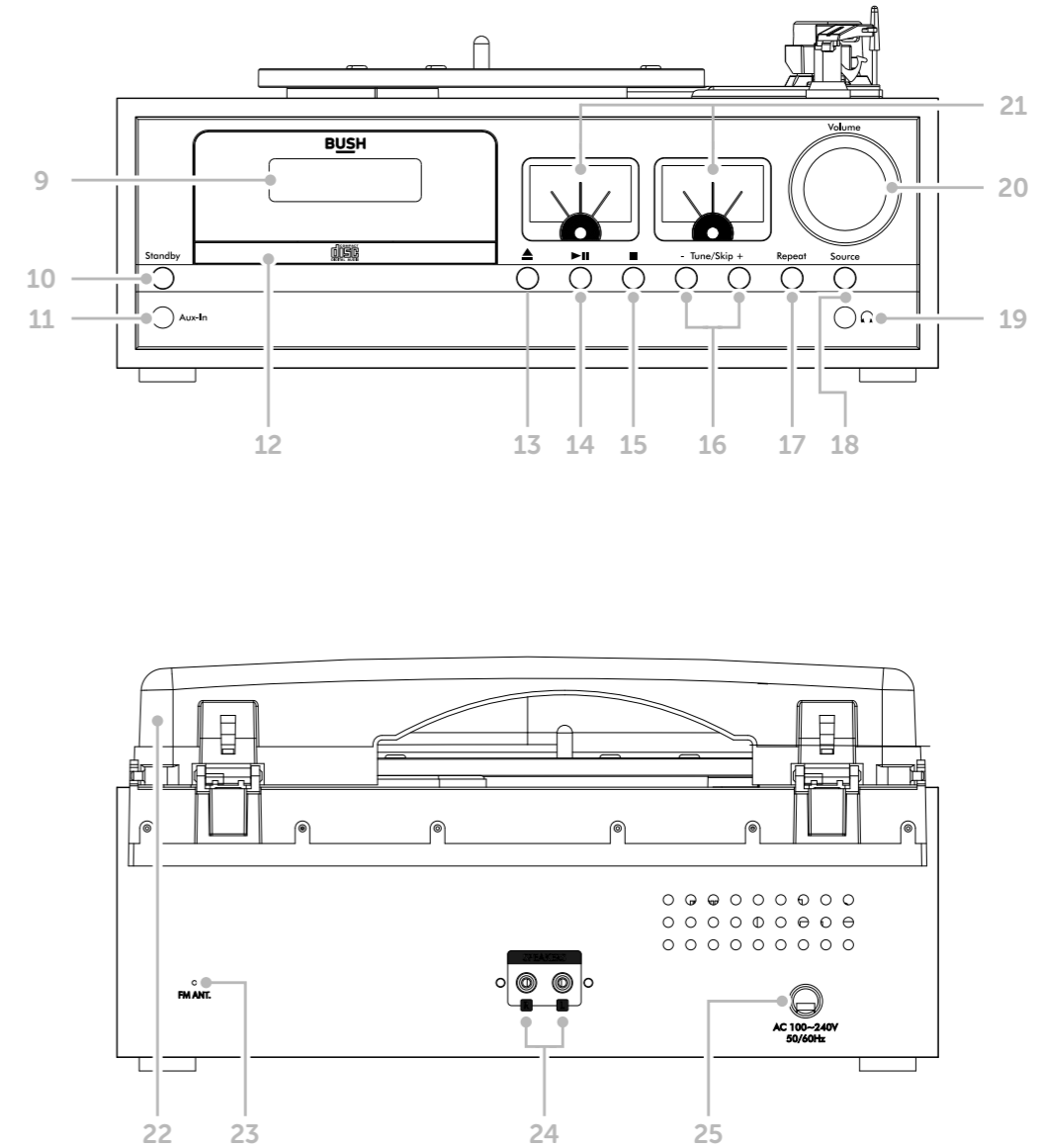

- | | |
|--|---|
| 9. Backlit display | 18. Source (Phono/CD/FM radio/Bluetooth/Aux in) |
| 10. Power on/Standby button | 19. Headphone socket |
| 11. Aux in socket | 20. Rotary volume control |
| 12. CD drawer | 21. VU meters |
| 13. CD drawer open/close | 22. Turntable dust cover |
| 14. Play/Pause and Disconnect (Bluetooth mode) | 23. FM radio wire aerial |
| 15. Stop (CD mode) | 24. RCA Speaker sockets |
| 16. Tune/Skip buttons | 25. Power cable |
| 17. Radio presets/CD repeat | |

If you require any technical guidance or find that your product is not operating as intended, a simple solution can often be found in the **Troubleshooting** section of these instructions,

or online at www.bush-support.com If you still require further assistance, call one of our experts on **0345 600 3021**.

Using your Retro Turntable 3

This page is left intentionally blank

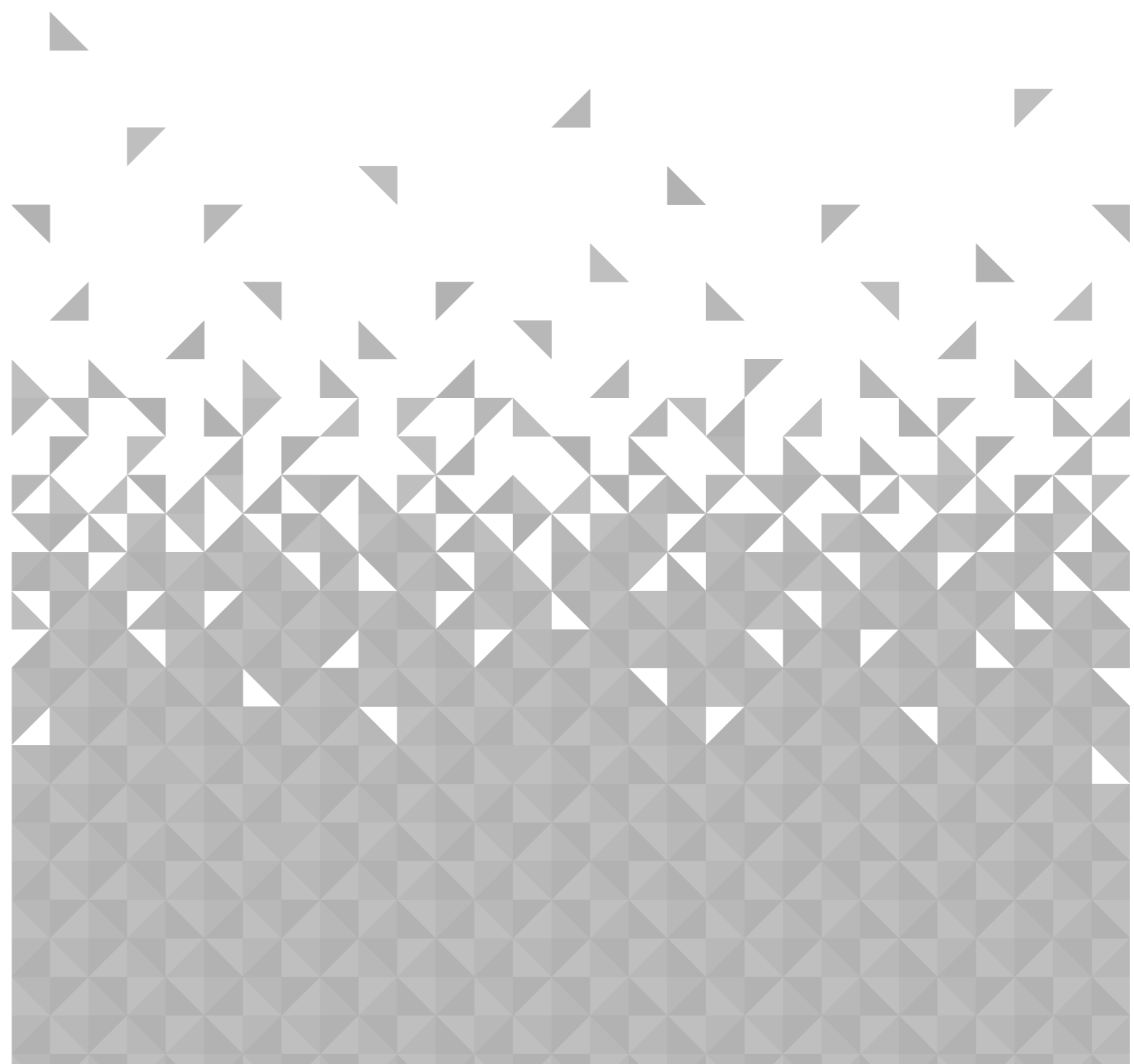

Using your Retro Turntable

Let's get started

Power on

Short press the Power button. Your Retro Turntable will turn on, 'PH' will be displayed. and your product will be in Phono/Turntable mode.

Power off

Short press the Power button. Your retro turntable will now be in Standby mode. To power off your product completely, please switch off the power at the mains wall socket.

Standby mode

This product is designed to go to Standby mode automatically after 20 minutes (approximately), if it does not receive an audio signal. Short press the Power button to switch your product back on again.

Changing the source (mode)

Short press the source button to change between Phono (Turntable), CD, FM Radio, Bluetooth and Aux in modes. Please check the display, which will confirm the mode.

Adjusting the volume

Turn the large right hand rotary volume control clockwise to increase the volume and anti-clockwise to decrease the volume.

Using headphones

You can connect headphones with a 3.5mm plug (not included) to the socket on the front of the Retro Turntable. When you have headphones connected the speakers are switched off and all sound is via the headphones.

Note: Always keep the volume within reasonable limits.

Phono/Turntable mode

Check that your Retro Turntable is in PH/Turntable mode. If you are not already in PH mode, repeatedly short press the Source button until you are in PH mode (check the display). PH will be displayed.

Auto Stop On/Off

Under the dust cover and to the right of the tone arm, there is an OFF/ON slide switch. This is for the turntable auto stop feature.

If you would prefer the turntable to only turn when the tone arm is moved over the record and to stop when the record stops, then set this switch to ON.

If you would prefer for the turntable to turn as soon as you select PH/Turntable mode and to continue turning even when the record you are playing comes to an end, you change to another mode or switch the Retro Turntable product to Standby mode, then set this switch to OFF.

Changing the Turntable speed (RPM)

Before you play a record, you need to check the correct speed or RPM that the record should be played at. Your Retro Turntable has 3 RPM speeds, 33, 45 and 78 RPM.

The RPM selector switch is under the dust cover and to the right of the tone arm.

1. Slide the RPM selector switch to 33, 45 or 78 RPM, as appropriate, to select the correct speed for your record.

Using your Retro Turntable

Let's get started

Playing a record

1. Lift the dust cover.
2. Check if the record you intend to play will need the spindle adapter and place this over the spindle, if necessary.
3. Place your record onto the turntable felt mat.
4. Check that you have removed the protective cover from the stylus and unclipped the tone arm.

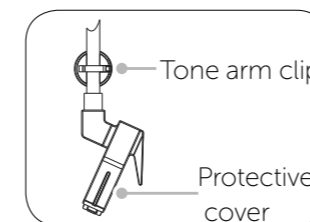

5. Select the correct speed for your record using the RPM selector switch.
6. Choose to turn the auto stop for the turntable on or off, as required.
7. Use the tone arm lever to lift the tone arm.
8. Move the tone arm across to your record.
9. Use the tone arm lever to gently lower the stylus onto the groove on your record. Your record will begin to play.
10. Use the large right hand rotary control to adjust the volume.
11. At the end of the record; if you have selected auto stop on, the turntable will stop turning automatically, if you have selected auto stop off the turntable will continue to turn until you change the mode or switch the product to Standby mode.
12. Use the tone arm lever to lift the tone arm.
13. Move the tone arm across to the rest position.

Suspend play

To temporarily suspend playing your record.

1. Use the tone arm lever to lift the tone arm and stylus from the record.



2. To resume play, use the tone arm lever to gently lower the stylus onto your record again.

CD Mode

Check that your Retro Turntable is in CD mode. If you are not already in CD mode, repeatedly short press the Source button until you are in CD mode (check the display). The display will show 'CD', followed by '- - -'. If the CD compartment is empty 'CD' will then be displayed.



Play a CD

Note: It is not possible to play DVD or computer CDs.

1. Short press the  button to open the CD drawer. 'OPEN' will be displayed.
2. Place an audio CD, label side up, onto the CD tray. Please ensure that the CD is laying flat within the recessed CD shaped area on the tray.
3. Short press the  button. The CD drawer will close, '- - -' will be displayed and after a short delay the first track will begin to play; the elapsed time of the track will be displayed.

CD controls

You can use the following controls on your Retro Turntable in CD mode.

- Play/Pause
Short press the  button The track number will flash in pause mode. Short press the  button again to continue to play the track/CD.
- Next track:
Short press the Tune/Skip + button
- Previous track:
Short press the Tune/Skip - button
- Stop
Short press the  button.

Using your Retro Turntable

Let's get started

Repeat and Random modes

1. Short press the Preset/Repeat button. A **REPEAT** icon is displayed. Continuously short press the Repeat button to cycle through the available options of:
 - **REPEAT** Repeat (current track)
 - **REPEAT** Repeat all (all the tracks on the CD)
 - **Random** Random (random play order)Short press the Preset/Repeat button one more time to turn off Repeat and Random modes.

Programmed play mode

In programmed play mode, you can program the play order of the tracks on your CD. You can program up to 20 tracks in total.

Note: To set up programmed play mode, the CD must be stopped in the CD compartment and must not be paused or playing.

In CD mode, with the CD you wish to programme in the CD compartment and stopped:

1. Short press the Repeat button to enter CD programmed play mode. 'P01' will be displayed.
2. Short press the Tune/Skip + or - buttons to go to the track number that you would like to program to play first. Short press the Repeat button to confirm.
3. 'P02' will now be displayed and you can select the second track that you would like to programme. Continue to select each track as in Step 2 above, up to a total of 20 tracks.

Note: After you have selected track 20 in the programmed play list 'FULL' will be displayed.

4. Short press the Repeat button again to confirm the last track in the programmed play mode list.
5. Short press the **Play/Pause** button to play the programmed tracks.
6. To exit programmed play mode, short press the **Stop** button twice.

Remove the CD

Short press the **Play/Pause** button. The CD drawer will open and 'OPEN' will be displayed.

Remove the CD from the compartment.

Short press the **Play/Pause** button to close the CD drawer. '- - -', followed by 'P0' will be displayed.

Note: If you stop or pause playing a CD for approximately 20 minutes, your product will go to Standby mode automatically.

Caring for compact discs

- Do NOT touch the playback side of the CD.
- Do NOT attach paper or tape or any other material to the disc.
- Fingerprints and dust on the disc will cause sound deterioration. Wipe the disc from the centre outwards with a soft cloth. Always keep the disc clean.
- If dust or marks cannot be removed with a soft cloth, wipe the disc lightly with a slightly damp soft cloth and then wipe with a soft dry cloth.
- Do NOT use any type of solvent, commercially available cleaners or antistatic spray for vinyl as it may damage the disc.
- Do NOT store discs in a place subject to direct sunlight or near a heat source.
- Do NOT store discs in a place subject to moisture or dust, such as a bathroom or near a humidifier.
- Always store discs vertically in a case, stacking or placing objects on discs may cause warping.

FM Radio mode

If you are not already in FM mode, repeatedly short press the Source button to go to FM mode (check the display). If you were listening to an FM station when you switched the product to standby mode then this station will be automatically selected when you switch the product back on.

Using your Retro Turntable

Let's get started

Wire radio aerial

Please make sure that the wire aerial on the back of the Retro turntable is fully extended and adjusted before you attempt to tune to an FM radio station (a vertical position is recommended). This will ensure that the maximum signal strength is available when the product begins to scan. Extending the aerial also ensures the best possible sound quality.

Tuning to an FM station

In FM mode:

Long press the Tune/Skip + button to scan up the frequency band.

Long press the Tune/Skip - button to scan down the frequency band.

Short press the Tune/Skip + or - button to adjust the frequency band in 0.05MHz steps.

Note: If reception is poor check that the wire aerial is fully extended or try moving the product to another location.

Storing an FM station preset

Your Retro Turntable can store up to 20 FM stations in its preset memories for instant access to your favourite stations.

1. Tune the Retro Turntable to the FM radio station that you wish to preset.
2. Long press the Repeat button until 'P XX' starts to flash on the display (where XX is the preset number).
3. Short press the Tune/Skip + or - button to move to the preset number that you would like to store the radio station to (1-20).
4. Short press the Repeat button. 'P XX' will stop flashing confirming that the preset has been stored.

Note: If there is already an existing FM station stored under a preset, it will be overwritten when you store new stations.

Tune to an FM station preset

In FM mode:

1. Repeatedly short press the Repeat button to move through the preset locations (1-20).
2. When you pause between each press, the frequency stored under each preset location will be displayed and your product will tune to and play the stored station.

Using Bluetooth mode

With your Retro turntable you can connect wirelessly to other compatible Bluetooth devices and stream music, which can then be heard through the Retro Turntable stereo speakers.

Before you can use your Retro Turntable in Bluetooth mode you need to 'pair' it with a Bluetooth capable device, such as an iPod/iPhone/iPad/tablet/Android/other phone/Computer.

1. If you are not already in Bluetooth mode, repeatedly short press the Source button to go to Bluetooth mode (check the display).
2. 'BT' will be displayed and a **Bluetooth** icon will flash in the top left of the display whilst your product searches for Bluetooth devices.
3. On the device that you would like to connect to your Turntable via Bluetooth (e.g. iPod/iPhone/iPad/Android/other phone/Tablet/Computer), turn on Bluetooth connectivity and ensure that it is 'discoverable'.

Note: If necessary, refer to the instructions for your device to add or set up Bluetooth.

4. When found, your Retro Turntable will be displayed as 'BUSH TT-1862'. Select the device name to begin pairing.

Note: If your device requests a password, please enter '0000' to complete the device pairing.

5. When pairing is complete the **Bluetooth** icon will stop flashing and remain continuously on.

Using your Retro Turntable

Let's get started

6. Now that you have paired your device with the Retro Turntable, it will connect to it when it is within range, which is about 10 metres or less (33 feet or less), line of sight.
7. Your device will remain paired with the Retro Turntable unless you decide to disconnect or 'unpair' it.

Note: If your previously paired device is within range but does not automatically connect, go to the Bluetooth connectivity settings on your device and select 'BUSH TT-1862' to reconnect.

Controlling a paired Bluetooth device

Once paired you can adjust the volume using the right hand rotary volume control. You can also use the controls on the connected audio device.

1. Select and start the music or audio that you wish to listen to on your paired Bluetooth device, it will now be heard through the Retro Turntable speakers. Adjust the volume on the connected device and/or your product.
2. You can use the controls on your paired Bluetooth device as well as those on the Retro Turntable when listening to music via Bluetooth.

Controls available on your product are:

- Play/Pause
 Short press to play/pause.

Note: If you long press the  button for 3 seconds, you can disconnect the current Bluetooth device and search for new devices.

- Skip back
Short press the Tune/Skip - button.
- Skip forward
Short press the Tune/Skip + button.

Note: If you do not use or pause your Retro Turntable for approximately 20 minutes and no audio signal is received, it will automatically go to Standby mode.

Aux in mode

Check that your Retro Turntable is in Aux in mode. If you are not already in Aux in mode, repeatedly short press the Source button to go to Aux in mode (check the display)

Using a 3.5mm audio input connection cable (not included), Aux in allows for a quick and easy connection to an external sound source.

1. Connect one end of the 3.5mm audio connection cable to the headphone (or auxiliary out) socket of your secondary device, connect the other end to the Aux in socket on the front of your Retro Turntable.
2. Press the Play button on your external device to start playback through the Retro turntable speakers.

To gain optimal volume levels, adjust the output volume level on both the secondary device and on the Retro turntable.

Note: It is recommended that you unplug the Audio cable from the Aux in socket after you have finished listening to your external device.

This page is left intentionally blank

Other information 4

This page is left intentionally blank



Other information

Helpful technical information

Technical specification

Power:	Input AC 230-240V/50Hz
Audio output:	2 x 5W RMS
Frequency range:	
FM:	87.5 MHz to 108 MHz
Bluetooth:	2.4GHz-2.480GHz
Version:	2.1
Profiles:	HFPV1.5, A2DPV1.2, AVRCPV1.4, HSP1.2, GAVDP1.2, IOP
Pairing name:	BUSH TT-1862



This product is a Class II or double insulated electrical appliance. It has been designed in such a way that it does not require a safety connection to electrical earth.

This page is left intentionally blank

This page is left intentionally blank



Product support

Help is always at hand

Troubleshooting

No power:

- Check the power plug connection at the wall socket.
- Short press the Power button to power on the Retro Turntable.

The tone arm skips grooves, slides over the record or does not move

- The Retro Turntable is not on a flat surface. Please move the product to a flat and stable surface
- The record is dirty or scratched. Clean the record with a record cleaner or play a different record.

The Turntable speed is incorrect.

- Select the correct speed according to the specification on the record. (33, 45 or 78 RPM).

Unable to pair with a Bluetooth device:

- Check that you are in Bluetooth mode.
- Ensure that you are within range of the Retro Turntable for Bluetooth functionality, 10 metres or less (33 feet or less).
- Move any other unnecessary Bluetooth devices/electrical equipment away from the Retro Turntable and if possible, turn them off or disable their Bluetooth functionality.

No sound / Sound distortion:

- Adjust the volume
- The stylus is dirty. Clean the stylus with a soft brush.
- The record is dirty or dusty. Clean the record with a record cleaner.
- If you are using Bluetooth, adjust the volume on the secondary connected device and on your Retro Turntable
- Check that you are in the correct mode for the music that you wish to listen to.

Retro Turntable powers off:

- Your Retro Turntable has been designed to automatically go to Standby mode after approximately 20 minutes without an audio signal, to save power. Short press the Power button to turn the product back on again.

Product support

Help is always at hand

Help and assistance

If you require any technical guidance or find that your Retro Turntable is not operating as intended, a simple solution can often be found in the **Troubleshooting** section of these instructions or online at www.bush-support.com

If you still require further assistance, call one of our experts on **0345 600 3021***. To help give us give you a fast and efficient service please have the following information ready:

Model Ref.	<input type="text"/>	You can find these on the rating plate - a small information panel (usually a sticker or metal plate) on the rear or base of your product
Serial number	<input type="text"/>	
Date of purchase	<input type="text"/>	This will be shown on your receipt

Local call rates applies*

Lines open 8am-7pm Monday to Saturday and 10am-4pm Sunday.

*Calls to Bush enquiry lines may attract a charge and set up fee from residential lines depending on your call plan/tariff. Mobile and other providers costs may vary, see www.bt.com/pricing for details.

For Security and training purposes, telephone calls to and from customer service centres maybe recorded and monitored. Calls from Republic of Ireland will attract international call charges.

Product support

Help is always at hand

Disposal



- Disposal of your old product. Your product is designed and manufactured with high quality materials and components, which can be recycled and reused
- When this crossed out wheeled bin symbol is attached to a product it means the product is covered by the European Directive 2012/19/EC.
- Please make yourself aware of the local collection system for electrical and electronic products.
- Please act according to your local rules and do not dispose of your old products with your normal household waste.
- The correct disposal of your old product will help prevent potential negative consequences for the environment and human health.

Bluetooth®

The Bluetooth® word mark and logos are registered trademarks owned by Bluetooth SIG, Inc. and any use of such marks is under license.



This product is intended for use within the UK. This equipment complies with the essential requirements of the Radio Equipment Directive 2014/53/EU.

Declaration of Conformance

Hereby, Argos Ltd, declares that this Retro Turntable - TT-1862 is in compliance with the essential requirements and other relevant provisions of the Radio Equipment Directive 2014/53/EU. The complete declaration of conformity can be obtained by contacting <http://www.bush-support.com/>

If you require any technical guidance or find that your product is not operating as intended, a simple solution can often be found in the **Troubleshooting** section of these instructions.

Product support

Help is always at hand

BUSH

Call us now and register your 12 month guarantee

Thank you for choosing Bush. Your new product is guaranteed against faults and breakdowns for 12 months. Don't forget to register it with us today so we can provide you with our best possible after-sales service and useful updates.

www.bushregistration.co.uk

FREEPHONE*

0800 597 8548

Lines are open 8am - 8pm, 365 days a year. *Calls may be recorded and monitored.

Your Bush Guarantee

This product is guaranteed for twelve months from the date of original purchase. Any defect that arises due to faulty materials or workmanship will be repaired free of charge (or if applicable the product will be replaced or the purchase price refunded) where possible during this period by the dealer from who your purchased the unit.

The guarantee is subject to the following provisions:

- The guarantee does not cover accidental damage, misuse, cabinet parts, knobs or consumable items.
- The product must be correctly installed and operated in accordance with the instructions contained in the manual.
- It must be used solely for domestic purposes. The guarantee will be rendered invalid if the product is re-sold or has been damaged by inexpert repair.
- Specifications are subject to change without notice.
- Bush disclaim any liability for loss or damage arising from the breakdown of the product.
- This guarantee is in addition to and does not diminish your statutory or legal rights.

Important Data Protection Information

To find out how we and Domestic & General Insurance Plc use your data please refer to the guarantee registration material or visit www.bushregistrations.co.uk.

Guarantor: Argos Limited - 489 - 499 Avebury Blvd. - Milton Keynes - MK9 2NW

or online at www.bush-support.com If you still require further assistance, call one of our experts on **0345 600 3021**.

BUSH *Classic*

Contact:

www.bush-support.com

Helpline: 0345 600 3021