

BUSH

Instruction manual

Multi Cyclonic Bagless Cylinder Vacuum Cleaner

Model: VCM40A16LOB-70

SKU: 134082072

Cat: 8455578



You'll soon be enjoying your new Bush Multi Cyclonic Bagless Cylinder Vacuum Cleaner.

It all begins here, with your instructions. Don't worry, there's nothing too technical coming up. Just simple, step-by-step guidance to get you up and running quickly. Sound good? Then let's get started.

Help and Guidance

We're here to help you get the most from your Bush Multi Cyclonic Bagless Cylinder Vacuum Cleaner.

Should you require any guidance; call our Help line on 0345 604 0105.

Further contact details can be found online at: www.bush-support.co.uk

If you require any technical guidance or find that your product is not operating as intended, a simple solution can often be found in the **Troubleshooting** section of these instructions

Contents

1	Safety information	
	Power source	6
	Ventilation heat and moisture	7
	Warning	7
	Plug / Wiring advice	8
2	Getting to know your vacuum cleaner	
	Accessories	10
	Parts	11
3	Installing your vacuum cleaner	
	Assembly	14
4	Using your vacuum cleaner	
	Getting started	16
	Nozzle use	17
	Storage	17
5	Care and maintenance	
	Maintenance	20
	Emptying the dust container	20
	Cleaning the filters	21
	Technical specification	23
6	Product support	
	Troubleshooting	26
	Help and assistance	27
	Recycling electrical products	28
	Guarantee	29

If you require any technical guidance or find that your product is not operating as intended, a simple solution can often be found in the **Troubleshooting** section of these instructions

Safety information 1

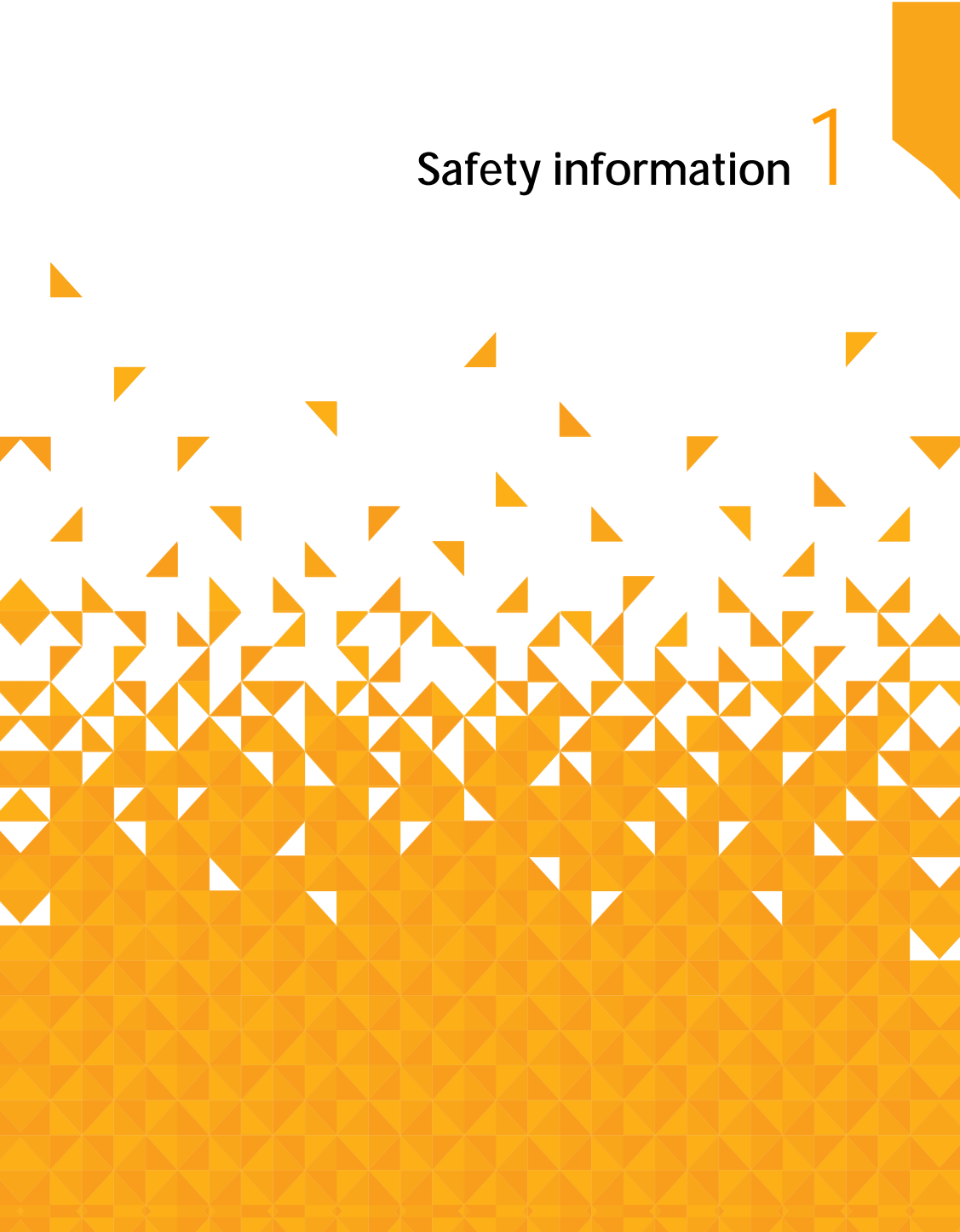



Safety information

Important - Please read these instructions fully before installing or operating

Power source

- For household and indoor use only
- Keep the appliance and its cord out of reach of children less than 8 years.
- Do not allow children to use the appliance without supervision.
- This appliance can be used by children aged from 8 years and above and persons with reduced physical, sensory or mental capabilities or lack of experience and knowledge if they have been given supervision or instruction concerning use of the appliance in a safe way and understand the hazards involved. Children shall not play with the appliance. Cleaning and user maintenance shall not be made by children unless they are aged from 8 years and above and supervised.
- Do not pull on the cable to disconnect from mains supply.
- Fully unwind the cable before plugging in and ensure the cable is positioned away from areas where it is likely to get damaged or cause a trip hazard.
- Do not operate the vacuum if damaged or after it malfunctions. In the event the supply cord is damaged, it must only be replaced by a qualified service engineer, with a suitably approved part.
- This appliance must be positioned so that the plug is accessible and the plug socket is within easy reach of the power cord.
- Switch off and unplug when not in use and before emptying, cleaning or servicing the appliance. Servicing of this appliance must only be carried out by a qualified electrician.

If you require any technical guidance or find that your product is not operating as intended, a simple solution can often be found in the **Troubleshooting** section of these instructions



Safety information

Important - Please read these instructions fully before installing or operating

Ventilation, heat and moisture

- Keep appliance, cable and plug away from areas where it is likely to get splashed. Never immerse in water.

Warning!

- Do not place fingers or other objects into the hose nozzle or under the floor head when the vacuum cleaner is in use.
- Do not run the appliance over the power cable.
- Do not use the appliance to pick up burning or hot objects (e.g. coal, ash, cigarettes etc) of any kind.
- Do not use the appliance to pick up any liquids or use on wet surfaces.
- Do not cover the appliance or restrict air vents.
- Do not use the appliance to pick up sharp objects (e.g. pins, nails, tacks, staples etc) or string.



Safety information

Important - Please read these instructions fully before installing or operating

Plug / Wiring advice

The wires in this mains lead are coloured in accordance with the following UK electrical code:

BLUE = NEUTRAL

BROWN = LIVE

Non-rewireable plug

This appliance may be fitted with a “non-rewireable” plug. If you need to change the fuse in a “non-rewireable” plug, the fuse cover must be refitted. If the fuse cover is lost or damaged, the appliance must not be used.

Rewireable plug

The colours of the wires in the mains lead of this appliance may not correspond with the coloured markings identifying the terminals in a rewireable plug. **Rewireable plugs should only be replaced by a suitably competent person. If in doubt, consult a qualified electrician.**

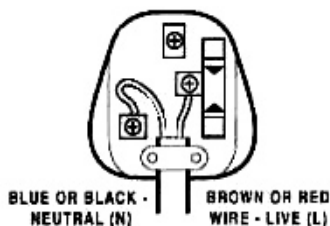

The BLUE wire must be connected to the terminal marked with the letter N

The BROWN wire must be connected to the terminal marked with the letter L

If you require any technical guidance or find that your product is not operating as intended, a simple solution can often be found in the **Troubleshooting** section of these instructions

Getting to know your vacuum 2



Getting to know your vacuum

You'll be up and running in no time

Ready? Let's begin...

Please read these instructions carefully. They contain important information which will help you get the best from your vacuum and ensure safe and correct installation and operation.

If you require any further assistance, our technical experts are happy to help. For full details, refer to the product support section at the end of these instructions.

Accessories

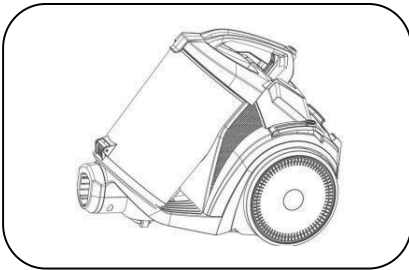

Vacuum cleaner

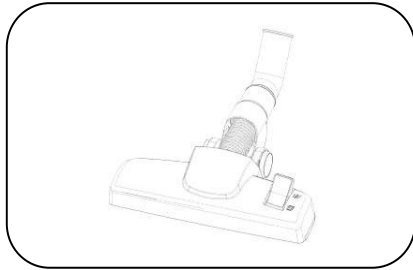

Floor head

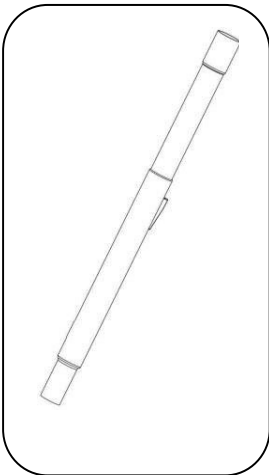

Extension tube

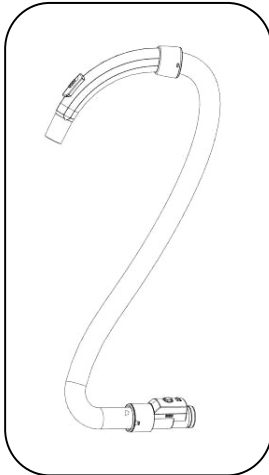

Flexible hose

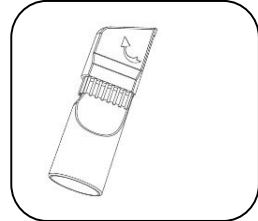

Combination nozzle

If you require any technical guidance or find that your product is not operating as intended, a simple solution can often be found in the **Troubleshooting** section of these instructions

Getting to know your vacuum

You'll be up and running in no time

Parts

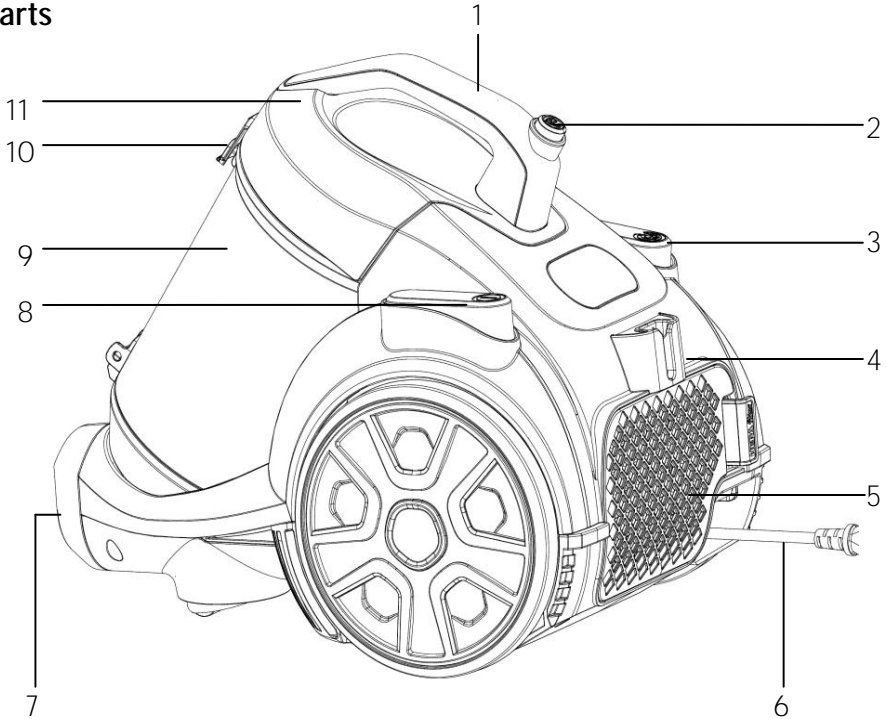

- | | | | |
|---|-------------------------------|----|----------------------|
| 1 | Carrying handle | 7 | Flexible hose socket |
| 2 | Dust container release button | 8 | ON/OFF button |
| 3 | Cable rewind button | 9 | Dust container |
| 4 | Floor head storage point | 10 | Dust container catch |
| 5 | Outlet filter cover | 11 | Dust container lid |
| 6 | Power cable | | |

Or by calling one of our experts on 0345 604 0105

If you require any technical guidance or find that your product is not operating as intended, a simple solution can often be found in the **Troubleshooting** section of these instructions

Installing your vacuum 3

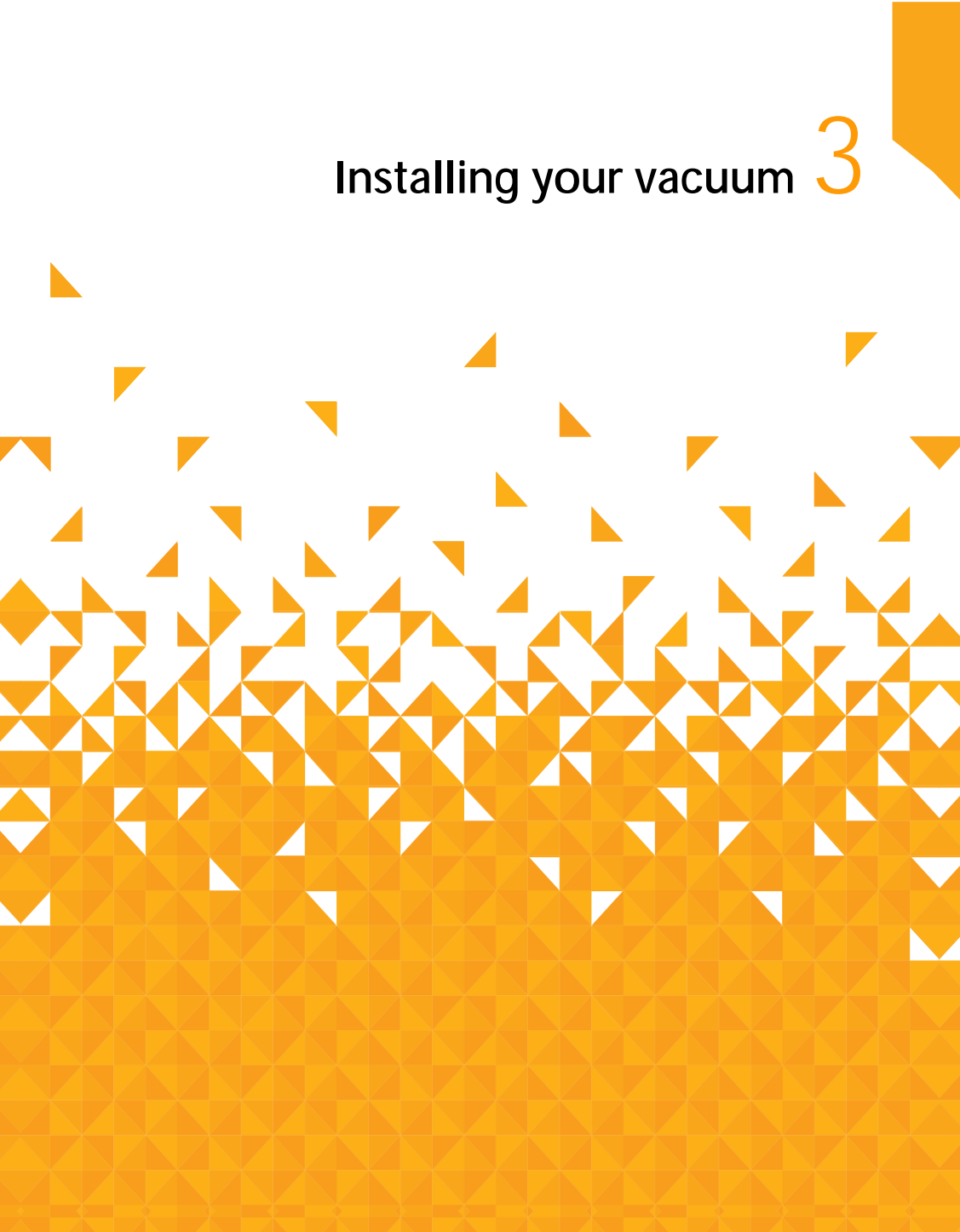

Installing your vacuum

Bringing it all together

Assembly

1. Insert the flexible hose coupling into the hose socket and push to secure, a click will be heard.
2. Fit the extension tube onto the end of the curved handle and push fit the floor head onto the extension tube (fig.1). The crevice nozzle can fit onto the curved handle and the extension tube in a similar manner.

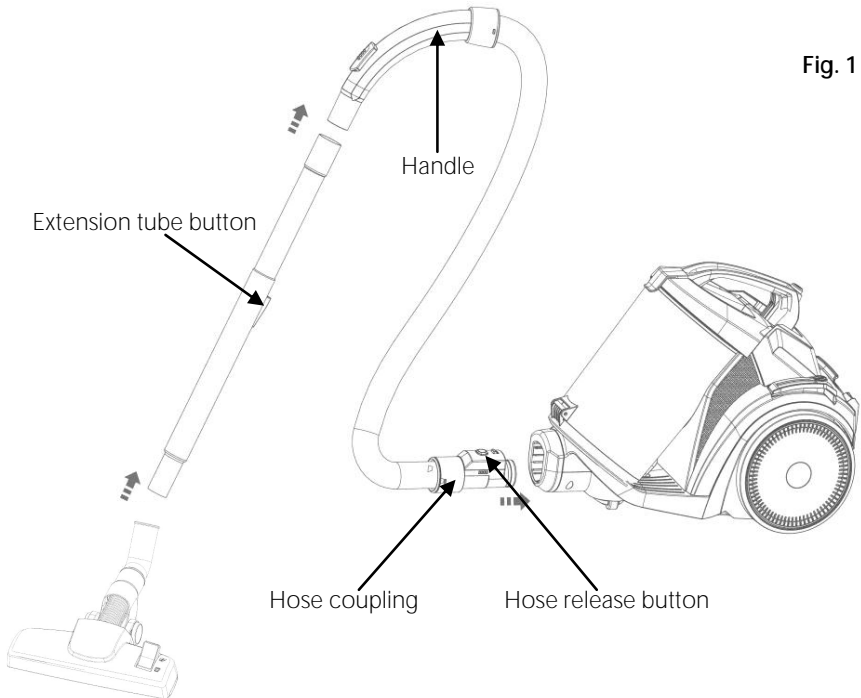

Fig. 1

3. To adjust the length of the extension tube, press the extension tube button and pull out the inner tube to the required length.
4. To remove the extension tube and accessories firmly pull apart.
5. To disconnect the flexible hose from the body of the cleaner ensure that vacuum cleaner is switched off. Squeeze the hose release button and pull apart.

If you require any technical guidance or find that your product is not operating as intended, a simple solution can often be found in the **Troubleshooting** section of these instructions

Using your vacuum 4



Using your vacuum

Let's get started

Getting started

1. Before use, pull out the cable until the yellow mark on the cable is visible. This is the ideal cable length. Do not extend the cable beyond the RED mark.
2. Fit the correct nozzle for the cleaning application (see next page) and plug the vacuum cleaner into the mains supply.
3. Press the ON/OFF button to start the vacuum cleaner and vacuum as required.
4. The suction can be released quickly by moving the suction release slider on the top of the flexible hose handle (fig. 2).
5. To raise or lower the brushes on the floor head (fig. 3) press or lift the floor head adjustment lever.
 - When cleaning carpets, raise the brushes on the floor head.
 - When cleaning hard floors, lower the brushes on the floor head.
6. Press the ON/OFF button again to switch the vacuum cleaner off after use and before disconnecting the plug from the mains supply.
7. Rewind the cable by pressing the cable rewind button. It is advisable to guide the cable with your hand to prevent the cable whipping and damaging the appliance or other household property. If the cable does not rewind completely, pull the cable out a small way and press the rewind button again.

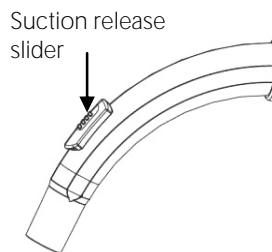

Fig. 2

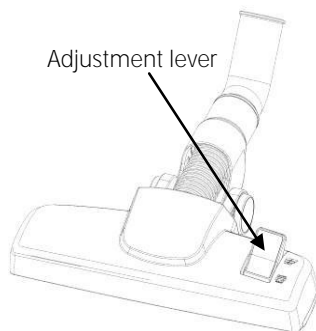

Fig. 3

If you require any technical guidance or find that your product is not operating as intended, a simple solution can often be found in the **Troubleshooting** section of these instructions

Using your vacuum

Let's get started

Nozzle use

Nozzle	Cleaning area							
	Floor & carpets	Furniture	Between cushions	Curtains	Stairs	Walls	Skirting edges	Radiators
Floor head	✓				✓			
Combination-brush		✓		✓	✓	✓		
Combination-crevice tool		✓	✓		✓		✓	✓

Storage

To store the vacuum cleaner tidily when not in use, slide the storage point on the floor head into the socket at the rear of the cleaner as shown (fig. 4).

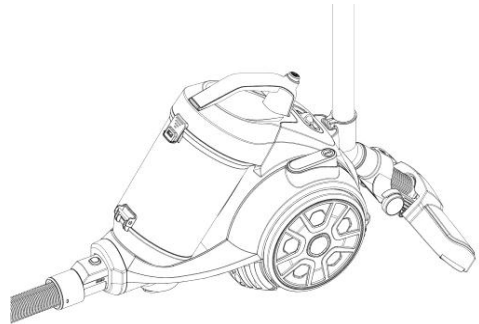

Fig. 4

If you require any technical guidance or find that your product is not operating as intended, a simple solution can often be found in the **Troubleshooting** section of these instructions

Care and maintenance 5



Care and maintenance

Looking after your appliance

Maintenance

Switch off and disconnect from the mains supply before carrying out cleaning and maintenance.

To ensure your vacuum cleaner works at optimum efficiency, keep the ventilation holes and vacuum cleaner surface free from dirt.

Ensure that the dust container is emptied and the air filters are washed regularly.

1. Wipe the outside of the vacuum cleaner and accessories with a damp (not wet) cloth and then wipe dry. Do not use detergents, solvents or abrasives as these may scratch or damage the surface.
2. Never immerse the vacuum cleaner, cable or plug in water.
3. When not in use, store in a cool, dry place.

Emptying the dust container

1. When the dust container reaches the MAX line marked on the dust container or when the suction power is reduced, it is time to empty the dust container.
2. Switch off and disconnect from the mains supply.
3. Press the dust container release button and lift off the dust container using the handle (fig.5).

Fig.5

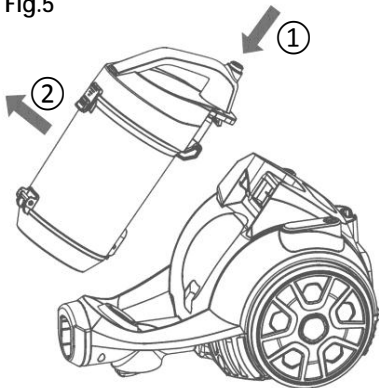
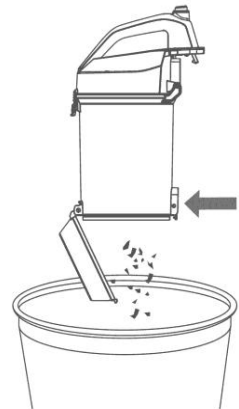

Fig.6



If you require any technical guidance or find that your product is not operating as intended, a simple solution can often be found in the **Troubleshooting** section of these instructions

Care and maintenance

Looking after your appliance

4. Position the dust container over a refuse bin, then press the lever at the rear of the container to open the base (fig. 6) and empty the container. Gently tap the container against the side of the bin to remove any stubborn dust.
5. The inside of the dust container maybe wiped clean with a damp cloth. Dry with a soft dry cloth before closing the flap and refitting the container to the cleaner. A click will be heard when it is correctly engaged.

Cleaning the filters

1. The frequency that the filters should be cleaned will depend on appliance usage. For maximum efficiency the filter at the top of the dust container should be cleaned every time the dust container is emptied and the exhaust filter every two months. Switch off and disconnect from the mains supply.
2. Remove the dust container from cleaner (fig. 5) and empty the dust container (fig.6).
3. To clean the dust container filter, flip open the lid of the dust container using the catch at the front of the dust container and lift out the filter (fig. 7).
4. **Tap the filter against a dustbin** to remove most of the dust and then wash the filter in cold running water until the water runs clear. **Allow to air dry fully.** Using a damp or wet filter will reduce the suction and damage the motor.

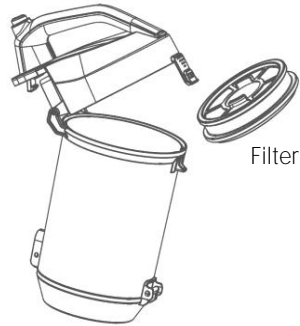

Fig. 7

Care and maintenance

Looking after your appliance

- The cyclone assembly can also be lifted from the dust container (fig.8) and washed under running water if needed (fig. 9).

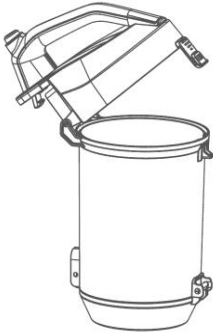

Fig. 8

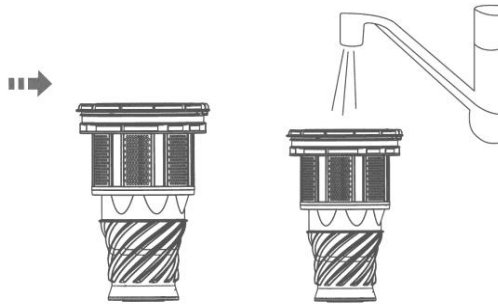
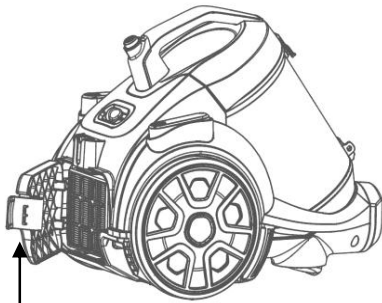

Fig.9

- When the filter and cyclone assembly is completely dry, reverse the above steps and refit the filter into the dust container and close the lid.
- To clean or replace the air outlet (HEPA) filter, press the catch at the side of the outlet filter cover (fig. 10) and lift off the cover. Wash and dry the filter (fig. 11) in accordance with step 4 above.
- Refit the filter and cover into the cleaner.



Catch

Fig. 10

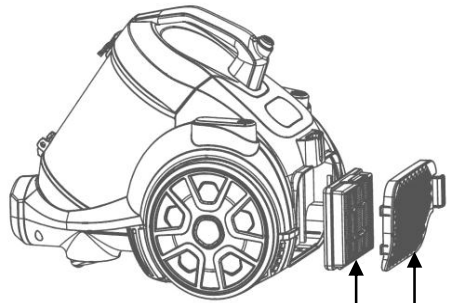

Fig. 11

HEPA filter Cover

Notes:

- Take care of the filters supplied, as replacements are not available.

If you require any technical guidance or find that your product is not operating as intended, a simple solution can often be found in the **Troubleshooting** section of these instructions

Other information

Technical Specification

Model	VCM40A16LOB-70
SKU	134082072
Rated voltage	220 – 240V~ 50Hz
Power	700W nominal 770W max
Class rating	II (double insulated)
BS 1362 fuse	13A
Dust Container Capacity	2.0 litres
Noise	78 dB(A)
Carpet cleaning performance class	D
Hard floor cleaning class	A
Dust re-emission class	A

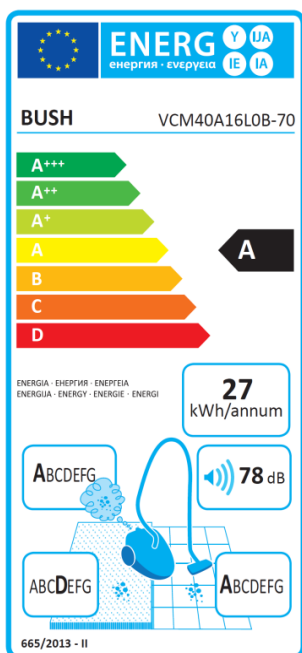

Or by calling one of our experts on 0345 604 0105

If you require any technical guidance or find that your product is not operating as intended, a simple solution can often be found in the **Troubleshooting** section of these instructions

Product support 5



Product support

Help is always at hand

Troubleshooting

Observation	Potential cause / solution
Vacuum cleaner does not work	Is the plug fully inserted into the mains socket and switched on?
	Do you have a power cut?
Suction power weak	Does the dust container need to be emptied?
	Are the filters clogged and need to be cleaned?
	Is the something blocking the nozzle?
Vacuum cleaner overheating	Is the filter clogged and need to be cleaned?
Dust escaping vacuum cleaner	Check that the dust container is securely fitted.

If you require any technical guidance or find that your product is not operating as intended, a simple solution can often be found in the **Troubleshooting** section of these instructions

Product support

Help is always at hand

Help and assistance

If you require any technical guidance or find that your Bush vacuum is not operating as intended, a simple solution can often be found in the **Troubleshooting** section of these instructions or online at www.bush-support.co.uk

If you still require further assistance, call one of our experts on 0345 604 0105*. To help give us give you a fast and efficient service please have the following information ready:

Model Ref:	<input type="text"/>	You can find this information on the rating plate – a small sticker (usually a sticker or metal plate on the rear of your product)
Serial number	<input type="text"/>	
Date of purchase	<input type="text"/>	This will be shown on your receipt

Local call rate applies*

Lines open 8am-7pm Monday to Saturday and
10am-4pm Sunday.

*Calls to Bush enquiry lines may attract a charge and set up fee from residential lines depending on your call plan / tariff. Mobile and providers costs may vary, see www.bt.com/pricing for details

For security and training purposes, telephone calls to and from customer service centres maybe recorded and monitored. Calls from Republic of Ireland will attract international call charges.

Product support

Help is always at hand

Recycling electrical products



You should now recycle your waste electrical goods and in doing so help the environment.

This symbol means an electrical product should not be disposed of with normal household waste. Please ensure it is taken to a suitable facility for disposal when finished with.

Visit www.recycle-more.co.uk, click on "bank locator" and enter your postcode to find your nearest recycling site.

If you require any technical guidance or find that your product is not operating as intended, a simple solution can often be found in the **Troubleshooting** section of these instructions

Product support

Help is always at hand

BUSH

Call us now and register your 12 month guarantee

Thank you for choosing Bush. Your new product is guaranteed against faults and breakdowns for 12 months. Don't forget to register it with us today so we can provide you with our best possible after-sales service and useful updates.

www.bushregistration.co.uk

FREEPHONE*

0800 597 8548

Lines open 8am-8pm, 365 days a year. *Calls may be recorded and monitored.

Your Bush Guarantee

This product is guaranteed for twelve months from the date of original purchase. Any defect that arises due to faulty materials or workmanship will be repaired free of charge (or if applicable the product will be replaced or the purchase price refunded) where possible during this period by the dealer from who you purchased the unit.

The guarantee is subject to the following provisions:

- The guarantee does not cover accidental damage, misuse, cabinet parts, knobs or consumable items.
- The product must be correctly installed and operated in accordance with the instructions contained in the manual.
- It must be used solely for domestic purposes. The guarantee will be rendered invalid if the product is re-sold or has been damaged by inexpert repair.
- Specifications are subject to change without notice.
- Bush disclaim any liability for loss or damage arising from the breakdown of the product.
- This guarantee is in addition to and does not diminish your statutory or legal rights.

Important Data Protection Information

To find out how we and Domestic & General Insurance PLC use your data please refer to the guarantee registration material or visit www.bushregistration.co.uk

Guarantor: Argos Limited - 489 - 499 Avebury Blvd. - Milton Keynes - MK9 2NW

Or by calling one of our experts on **0345 604 0105**

If you require any technical guidance or find that your product is not operating as intended, a simple solution can often be found in the **Troubleshooting** section of these instructions

Or by calling one of our experts on **0345 604 0105**

BUSH

Produced for Bush
489-499 Avebury Boulevard, Milton Keynes MK9 2NW
Made in China.

Bush is a registered trademark of Argos Ltd.

Issue 1 06/18