

# BUSH

## Instruction manual

MOBILE TYPE AIR CONDITIONER  
(Local Air Conditioner)

Model number: (7K)  
MPPA-07CRN7-QB6(A)

Model number: (9K)  
MPPA-09CRN7-QB6(A)

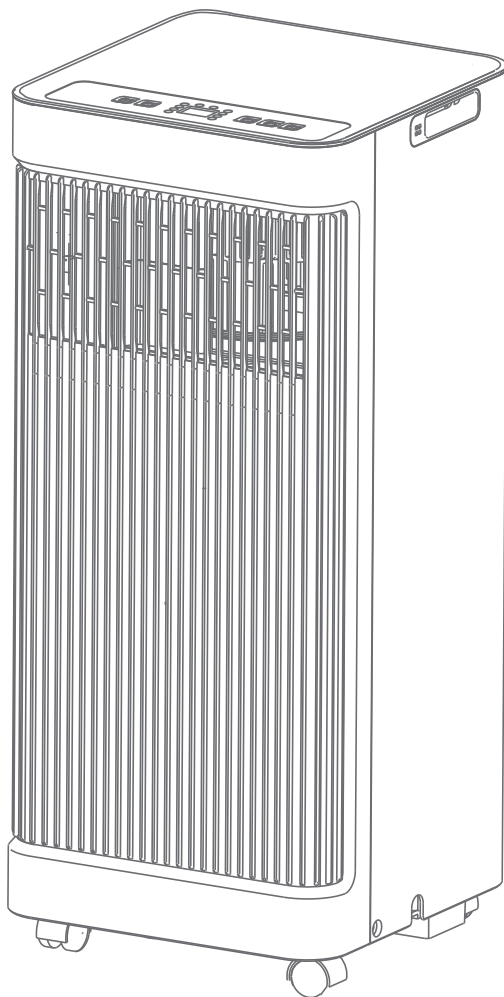

Please read the instructions fully before use.



# CONTENTS

Safety Information .....	02
Before you get started .....	10
Product Overview .....	12
Installation overview .....	13
Installation guide .....	14
Get to know your AC .....	16
Drainage guide .....	23
Cleaning and Maintenance .....	24
Store the unit when not in use .....	25
Troubleshooting .....	26
Disposal And Recycling .....	27
Product Support .....	28

# Safety Information

It's really important you read Safety Precautions Before Operation and Installation. Incorrect installation due to ignoring instructions can cause serious damage or injury. The seriousness of potential damage or injuries is classified as either a WARNING or CAUTION.

## Explanation of Symbols



### WARNING

This symbol indicates the possibility of personnel injury or loss of life.



### CAUTION

This symbol indicates the possibility of property damage or serious consequences.

## WARNING

- Installation must be performed according to the installation instructions. Improper installation can cause water leakage, electrical shock, or fire.
- Use only the included accessories and parts, and specified tools for the installation. Using non-standard parts can cause water leakage, electrical shock, fire, and injury or property damage.
- Make sure that the outlet you are using is grounded and has the appropriate voltage. The power cord is equipped with a three-prong grounding plug to protect against shock. Voltage information can be found on the nameplate of the unit.
- Your unit must be used in a properly grounded socket outlet. If the socket outlet you intend to use is not adequately grounded or protected by a time delay fuse or circuit breaker (the fuse or circuit breaker needed is determined by the maximum current of the unit. The maximum current is indicated on the nameplate located on unit), have a qualified electrician install the proper receptacle.
- Do not touch the unit with wet or damp hands or when barefoot.
- If the air conditioner is knocked over during use, turn off the unit and unplug it from the main power supply immediately. Visually inspect the unit to ensure there is no damage. If you suspect the unit has been damaged, contact a technician or customer service for assistance.
- In a thunderstorm, unplug the air conditioner to avoid damage to the machine due to lightning.
- Your air conditioner should be used in such a way that it is protected from moisture. e.g. condensation, splashed water, etc. Do not place or store your air conditioner where it can fall or be pulled into water or any other liquid. Unplug immediately if it occurs.
- Install the unit on a flat, sturdy surface. Failure to do so could result in damage or excessive noise and vibration.
- The unit must be kept free from obstruction to ensure proper function and to mitigate safety hazards.
- Do not modify the length of the power cord or use an extension cord to power the unit.
- Do not share a single outlet with other electrical appliances. Improper power supply can cause fire or electrical shock.

- Do not install your air conditioner in a wet room such as a bathroom or laundry room. Too much exposure to water can cause electrical components to short circuit.
- Do not install the unit in a location that may be exposed to combustible gas, as this could cause fire.
- The unit has wheels to facilitate moving. Make sure not to use the wheels on thick carpet or to roll over objects, as these could cause tipping.
- Do not operate a unit that it has been dropped or damaged.
- The appliance with electric heater shall have at least 1 meter space to the combustible materials.
- All wiring must be performed strictly in accordance with the wiring diagram located inside of the unit.
- The unit's circuit board (PCB) is designed with a fuse to provide overcurrent protection. The specifications of the fuse are printed on the circuit board, such as: T 3.15A/250V, etc.
- When the water drainage function is not in use, keep the upper and the lower drain plug firmly to the unit to get rid of choking. When the drain plug is not in use, keep it carefully to prevent children from choking.

## CAUTION

- This appliance can be used by children aged from 8 years and above and person with reduced physical, sensory or mental capabilities or lack of experience and knowledge if they have been given supervision or instruction concerning use of the appliance in a safe way and understand the hazards involved. Children shall not play with the appliance. Cleaning and user maintenance shall not be made by children without supervision.
- Children must be supervised around the unit at all times.
- If the supply cord is damaged, it must be replaced by the manufacturer, its service agent or similarly qualified persons in order to avoid a hazard.
- Do not use this product for functions other than those described in this instruction manual. Before cleaning, turn off the power and unplug the unit.
- Disconnect the power if strange sounds, smell, or smoke comes from it.
- Do not press the buttons on the control panel with anything other than your fingers.
- Do not remove any fixed covers.
- Never use this appliance if it is not working properly, or if it has been dropped or damaged.
- Do not operate or stop the unit by inserting or pulling out the power cord plug.
- Do not use hazardous chemicals to clean or come into contact with the unit. Do not use the unit in the presence of inflammable substances or vapour such as alcohol, insecticides, petrol, etc.

## CAUTION

- Prior to cleaning or other maintenance, the appliance must be disconnected from the supply mains.
- Do not remove any fixed covers. Never use this appliance if it is not working properly, or if it has been dropped or damaged.
- Do not run cord under carpeting. Do not cover cord with throw rugs, runners, or similar coverings. Do not route cord under furniture or appliances. Arrange cord away from traffic area and where it will not be tripped over.
- Do not operate unit with a damaged cord, plug, power fuse or circuit breaker. Discard unit or return to an authorized service facility for examination and/or repair.
- To reduce the risk of fire or electric shock, do not use this fan with any solid-state speed control device.

- Contact the authorised service technician for repair or maintenance of this unit.
- Contact the authorised installer for installation of this unit.
- Do not cover or obstruct the inlet or outlet grilles.
- Always transport your air conditioner in a vertical position and stand on a stable, level surface during use.
- Always contact a qualified person to carry out repairs. If the damaged power supply cord must be replaced with a new power supply cord obtained from the product manufacturer and not repaired.
- Hold the plug by the head of the power plug when taking it out.  
Turn off the product when not in use.

## **⚠ WARNING for Using R290 Refrigerant**

- Do not use means to accelerate the defrosting process or to clean, other than those recommended by the manufacturer.
- The appliance shall be stored in a room without continuously operating ignition sources (for example: open flames, an operating gas appliance or an operating electric heater).
- Do not pierce or burn.
- Be aware that the refrigerants may not contain an odour.
- Appliance should be installed, operated and stored in a room with a floor area according to the amount of refrigerant to be charged. For specific information on the type of gas and the amount, please refer to the relevant label on the unit itself. When there are differences between the label and the manual on the Min. room area description, the description on label shall prevail.

### **For R290**





<b>amount of refrigerant (kg)</b>	<b>Min. room area(m<sup>2</sup>)</b>	<b>amount of refrigerant (kg)</b>	<b>Min. room area(m<sup>2</sup>)</b>
≤ 0.0836	4	> 0.1881 and ≤ 0.2090	10
>0.0836 and ≤0.1045	5	>0.2090 and ≤ 0.2299	11
>0.1045 and ≤ 0.1254	6	>0.2299 and ≤ 0.2508	12
>0.1254 and ≤ 0.1463	7	>0.2508 and ≤ 0.2717	13
>0.1463 and ≤ 0.1672	8	>0.2717 and ≤ 0.2926	14
>0.1672 and ≤ 0.1881	9	>0.2926 and ≤ 0.3040	15

- Compliance with national gas regulations shall be observed. Keep ventilation openings clear of obstruction.
- The appliance shall be stored so as to prevent mechanical damage from occurring. A warning that the appliance shall be stored in a well-ventilated area where the room size corresponds to the room area as specified for operation.
- Any person who is involved with working on or breaking into a refrigerant circuit should hold a current valid certificate from an industry-accredited assessment authority, which authorises their competence to handle refrigerants safely in accordance with an industry recognised assessment specification.
- Servicing shall only be performed as recommended by the equipment manufacturer. Maintenance and repair requiring the assistance of other skilled personnel shall be carried out under the supervision of the person competent in the use of flammable refrigerants.
- Please follow the instruction carefully to handle, install, clear, service the air conditioner to avoid any damage or hazard. Flammable Refrigerant is used within air conditioner. When maintaining or disposing the air conditioner, the refrigerant (R32 or R290) shall be recovered properly, shall not discharge to air directly.
- Do not use open flames or operate devices that may produce sparks or arcing (such as electrical switches) near the air conditioner. This could ignite the flammable refrigerant inside the unit.
- Always follow the instructions in this manual when storing or servicing the air conditioner to prevent mechanical damage that could compromise safety. Flammable refrigerant is used in air conditioner. Please follow the instruction carefully to avoid any hazard. For special information on the type of gas and the amount, please to the relevant label on the unit itself.
- The appliance shall be stored in a room without continuously operating open flames (for example an operating gas appliance) and ignition sources (for example an operating electric heater).



**Caution:  
Risk of fire/flammable materials  
(Required for R32/R290 units only)**

Explanation of symbols displayed on the unit (For the unit adopts R32/ R290 Refrigerant only):

	<b>WARNING</b>	This symbol shows that this appliance used a flammable refrigerant. If the refrigerant is leaked and exposed to an external ignition source, there is a risk of fire.
	<b>CAUTION</b>	This symbol shows that the operation manual should be read carefully.
	<b>CAUTION</b>	This symbol shows that a service personnel should be handling this equipment with reference to the installation manual.
	<b>CAUTION</b>	This symbol shows that information is available such as the operating manual or installation manual.

1. Transport of equipment containing flammable refrigerants - See transport regulations
2. Marking of equipment using signs - See local regulations.
3. Disposal of equipment using flammable refrigerants - See national regulations.
4. Storage of equipment/appliances. The storage of equipment should be in accordance with the manufacturer's instructions.

**5. Storage of packed (unsold) equipment** .Storage package protection should be constructed such that mechanical damage to the equipment inside the package will not cause a leak of the refrigerant charge. The maximum number of pieces of equipment permitted to be stored together will be determined by local regulations.

**6. Information on servicing**

**a)Checks to the area**

Prior to beginning work on systems containing flammable refrigerants, safety checks are necessary to ensure that the risk of ignition is minimised. For repair to the refrigerating system, the following precautions shall be complied with prior to conducting work on the system.

**b)Work procedure**

Work shall be undertaken under a controlled procedure so as to minimise the risk of a flammable gas or vapour being present while the work is being performed.

**c)General work area**

All maintenance staff and others working in the local area shall be instructed on the nature of work being carried out. Work in confined spaces shall be avoided. The area around the workspace shall be sectioned off. Ensure that the conditions within the area have been made safe by control of flammable material.

**d)Checking for presence of refrigerant**

The area shall be checked with an appropriate refrigerant detector prior to and during work, to ensure the technician is aware of potentially flammable atmospheres. Ensure that the leak detection equipment being used is suitable for use with flammable refrigerants, i.e. non-sparking, adequately sealed or intrinsically safe.

**e)Presence of fire extinguisher**

If any hot work is to be conducted on the refrigeration equipment or any associated parts, appropriate fire extinguishing equipment shall be available to hand. Have a dry powder or CO<sub>2</sub> fire extinguisher adjacent to the charging area.

**f)No ignition sources**

No person carrying out work in relation to a refrigeration system which involves exposing any pipe work that contains or has contained flammable refrigerant shall use any sources of ignition in such a manner that it may lead to the risk of fire or explosion. All possible ignition sources, including cigarette smoking, should be kept sufficiently far away from the site of installation, repairing, removing and disposal, during which flammable refrigerant can possibly be released to the surrounding space. Prior to work taking place, the area around the equipment is to be surveyed to make sure that there are no flammable hazards or ignition risks. No Smoking signs shall be displayed.

**g)Ventilated area**

Ensure that the area is in the open or that it is adequately ventilated before breaking into the system or conducting any hot work. A degree of ventilation shall continue during the period that the work is carried out. The ventilation should safely disperse any released refrigerant and preferably expel it externally into the atmosphere.

**h)Checks to the refrigeration equipment**

Where electrical components are being changed, they shall be fit for the purpose and to the correct specification. At all times the manufacturer's maintenance and service guidelines shall be followed. If in doubt consult the manufacturer's technical department for assistance. The following checks shall be applied to installations using flammable refrigerants: The charge size is in accordance with the room size within which the refrigerant containing parts are installed; The ventilation machinery and outlets are operating adequately and are not obstructed; If an indirect refrigerating circuit is being used, the secondary circuit shall be checked for the presence of refrigerant; Marking to the equipment continues to be visible and legible. Markings and signs that are illegible shall be corrected; Refrigeration pipe or components are installed in a position where they are unlikely to be exposed to any substance which may corrode refrigerant containing components, unless the components are constructed of materials which are inherently resistant to being corroded or are suitably protected against being so corroded.

### i) Checks to electrical devices

Repair and maintenance to electrical components shall include initial safety checks and component inspection procedures. If a fault exists that could compromise safety, then no electrical supply shall be connected to the circuit until it is satisfactorily dealt with. If the fault cannot be corrected immediately but it is necessary to continue operation, an adequate temporary solution shall be used. This shall be reported to the owner of the equipment so all parties are advised.

Initial safety checks shall include:

That capacitors are discharged: this shall be done in a safe manner to avoid possibility of sparking; That there no live electrical components and wiring are exposed while charging, recovering or purging the system; That there is continuity of earth bonding.

## 7. Repairs to sealed components

1) During repairs to sealed components, all electrical supplies shall be disconnected from the equipment being worked upon prior to any removal of sealed covers, etc. If it is absolutely necessary to have an electrical supply to equipment during servicing, then a permanently operating form of leak detection shall be located at the most critical point to warn of a potentially hazardous situation.

2) Particular attention shall be paid to the following to ensure that by working on electrical components, the casing is not altered in such a way that the level of protection is affected. This shall include damage to cables, excessive number of connections, terminals not made to original specification, damage to seals, incorrect fitting of glands, etc. Ensure that apparatus is mounted securely. Ensure that seals or sealing materials have not degraded such that they no longer serve the purpose of preventing the ingress of flammable atmospheres. Replacement parts shall be in accordance with the manufacturer's specifications.

**NOTE:** The use of silicon sealant may inhibit the effectiveness of some types of leak detection equipment. Intrinsically safe components do not have to be isolated prior to working on them.

## 8. Repairs to intrinsically safe component

Do not apply any permanent inductive or capacitance loads to the circuit without ensuring that this will not exceed the permissible voltage and current permitted for the equipment in use. Intrinsically safe components are the only types that can be worked on while live in the presence of a flammable atmosphere. The test apparatus shall be at the correct rating.

Replace components only with parts specified by the manufacturer. Other parts may result in the ignition of refrigerant in the atmosphere from a leak

## 9. Cabling

Check that cabling will not be subject to wear, corrosion, excessive pressure, vibration, sharp edges or any other adverse environmental effects. The check shall also take into account the effects of aging or continual vibration from sources such as compressors or fans.

## 10. Detection of flammable refrigerants

Under no circumstances shall potential sources of ignition be used in the searching for or detection of refrigerant leaks. A halide torch (or any other detector using a naked flame) shall not be used.

## 11. Leak detection methods

The following leak detection methods are deemed acceptable for systems containing flammable refrigerants. Electronic leak detectors shall be used to detect flammable refrigerants, but the sensitivity may not be adequate, or may need re-calibration. (Detection equipment shall be calibrated in a refrigerant-free area.) Ensure that the detector is not a potential source of ignition and is suitable for the refrigerant used. Leak detection equipment shall be set at a percentage of the LFL of the refrigerant and shall be calibrated to the refrigerant employed and the appropriate percentage of gas (25 % maximum) is confirmed.

## 12. Leak detection fluids

are suitable for use with most refrigerants but the use of detergents containing chlorine shall be avoided as the chlorine may react with the refrigerant and corrode the copper pipe-work. If a leak is suspected, all naked flames shall be removed/extinguished. If a leakage of refrigerant is found which requires brazing, all of the refrigerant shall be recovered from the system, or isolated (by means of shut off valves) in a part of the system remote from the leak. Oxygen free nitrogen (OFN) shall then be purged through the system both before and during the brazing process.

## 13. Removal and evacuation

When breaking into the refrigerant circuit to make repairs or for any other purpose conventional procedures shall be used. However, it is important that best practice is followed since flammability is a consideration. The following procedure shall be adhered to: Remove refrigerant; Purge the circuit with inert gas; Evacuate; Purge again with inert gas; Open the circuit by cutting or brazing.

The refrigerant charge shall be recovered into the correct recovery cylinders. The system shall be flushed with OFN to render the unit safe. This process may need to be repeated several times. Compressed air or oxygen shall not be used for this task. Flushing shall be achieved by breaking the vacuum in the system with OFN and continuing to fill until the working pressure is achieved, then venting to atmosphere, and finally pulling down to a vacuum. This process shall be repeated until no refrigerant is within the system. When the final OFN charge is used, the system shall be vented down to atmospheric pressure to enable work to take place. This operation is absolutely vital if brazing operations on the pipe-work are to take place. Ensure that the outlet for the vacuum pump is not close to any ignition sources and there is ventilation available.

## 14. Charging procedures

In addition to conventional charging procedures, the following requirements shall be followed. Ensure that contamination of different refrigerants does not occur when using charging equipment. Hoses or lines shall be as short as possible to minimise the amount of refrigerant contained in them. Cylinders shall be kept upright.

Ensure that the refrigeration system is earthed prior to charging the system with refrigerant. Label the system when charging is complete (if not already).

Extreme care shall be taken not to overfill the refrigeration system. Prior to recharging the system it shall be pressure tested with OFN. The system shall be leak tested on completion of charging but prior to commissioning. A follow up leak test shall be carried out prior to leaving the site.

## 15. Decommissioning

Before carrying out this procedure, it is essential that the technician is completely familiar with the equipment and all its detail. It is recommended good practice that all refrigerants are recovered safely. Prior to the task being carried out, an oil and refrigerant sample shall be taken in case analysis is required prior to re-use of reclaimed refrigerant. It is essential that electrical power is available before the task is commenced.

- a) Become familiar with the equipment and its operation.
- b) Isolate system electrically.
- c) Before attempting the procedure ensure that: Mechanical handling equipment is available, if required, for handling refrigerant cylinders; All personal protective equipment is available and being used correctly; The recovery process is supervised at all times by a competent person; Recovery equipment and cylinders conform to the appropriate standards.
- d) Pump down refrigerant system, if possible.
- e) If a vacuum is not possible, make a manifold so that refrigerant can be removed from various parts of the system.
- f) Make sure that cylinder is situated on the scales before recovery takes place.

- g) Start the recovery machine and operate in accordance with manufacturer's instructions.
- h) Do not overfill cylinders. (No more than 80 % volume liquid charge).
- i) Do not exceed the maximum working pressure of the cylinder, even temporarily.
- j) When the cylinders have been filled correctly and the process completed, make sure that the cylinders and the equipment are removed from site promptly and all isolation valves on the equipment are closed off.
- k) Recovered refrigerant shall not be charged into another refrigeration system unless it has been cleaned and checked. cylinders. (No more than 80 % volume liquid charge).
- i) Do not exceed the maximum working pressure of the cylinder, even temporarily.
- j) When the cylinders have been filled correctly and the process completed, make sure that the cylinders and the equipment are removed from site promptly and all isolation valves on the equipment are closed off.
- k) Recovered refrigerant shall not be charged into another refrigeration system unless it has been cleaned and checked.

## 16. Labelling

Equipment shall be labelled stating that it has been de-commissioned and emptied of refrigerant. The label shall be dated and signed. Ensure that there are labels on the equipment stating the equipment contains flammable refrigerant.

## 17. Recovery

When removing refrigerant from a system, either for servicing or decommissioning, it is recommended good practice that all refrigerants are removed safely. When transferring refrigerant into cylinders, ensure that only appropriate refrigerant recovery cylinders are employed. Ensure that the correct number of cylinders for holding the total system charge is available. All cylinders to be used are designated for the recovered refrigerant and labelled for that refrigerant (i.e. special cylinders for the recovery of refrigerant).

Cylinders shall be complete with pressure relief valve and associated shut-off valves in good working order. Empty recovery cylinders are evacuated and, if possible, cooled before recovery occurs. The recovery equipment shall be in good working order with a set of instructions concerning the equipment that is at hand and shall be suitable for the recovery of flammable refrigerants. In addition, a set of calibrated weighing scales shall be available and in good working order. Hoses shall be complete with leak-free disconnect couplings and in good condition. Before using the recovery machine, check that it is in satisfactory working order, has been properly maintained and that any associated electrical components are sealed to prevent ignition in the event of a refrigerant release.

Consult manufacturer if in doubt. The recovered refrigerant shall be returned to the refrigerant supplier in the correct recovery cylinder, and the relevant Waste Transfer Note arranged. Do not mix refrigerants in recovery units and especially not in cylinders. If compressors or compressor oils are to be removed, ensure that they have been evacuated to an acceptable level to make certain that flammable refrigerant does not remain within the lubricant. The evacuation process shall be carried out prior to returning the compressor to the suppliers. Only electric heating to the compressor body shall be employed to accelerate this process. When oil is drained from a system, it shall be carried out safely.

# Before you get started



The installation must be carried out in strict accordance with the instructions in this manual.



Installing your AC should take about 30 minutes.



We recommend doing this with a helper.



We're here if you need us, please contact your local distributor for assistance.

## ! AMBIENT TEMPERATURE RANGE FOR UNIT OPERATING

MODE	Temperature Range
Cool	16-35°C (60-95°F)
Dry	13-35°C (55-95°F)

## Know your mobile type Air Conditioner

### Energy Rating Information

The energy rating and noise information for this unit is based on the standard installation using an un-extended exhaust duct without window slider adaptor (as shown in the Installation section of this manual). At the same time, the unit must be operate on the COOL MODE and HIGH FAN SPEED by remote controller.

#### NOTE:

We recommend that operating the unit at room temperature below 35°C .

### How to: purchasing a mobile type air conditioner.

The right air conditioner helps you cool a room efficiently. An undersized unit won't cool adequately while one that's too large will not remove enough humidity, leaving the air feeling damp. To find the proper air conditioner, determine the square footage of the room you want to cool by multiplying the room length by its width. You also need to know the air conditioner's BTU (British Thermal Unit) rating, which indicates the amount of heat it can remove from a room. A higher number means more cooling power for a larger room. (Be sure you are comparing only newer models to each other older models may appear to have a higher capacity, but are actually the same). Be sure to "size up" if your portable air conditioner will be placed in a very sunny room, in a kitchen, or in a room with high ceilings. After you' ve found the right cooling capacity or your room, you can look at other features.

## PRODUCT INSTALLATION LOCATION

### Your installation location should meet the following requirements:

- Make sure that you install your unit on an even surface to minimize noise and vibration.
- The unit must be installed near a grounded plug, and the Collection Tray Drain (found on the back of the unit) must be accessible.
- The unit should be located at least 30cm (12") from the nearest wall to ensure proper air conditioning. The air outlet of the unit should be at least 50cm(19.7") away from obstacles.
- DO NOT cover the Intakes, Outlets or Remote Signal Receptor of the unit, as this could cause damage to the unit.

### Unit Installation Location Restricted Space Requirements

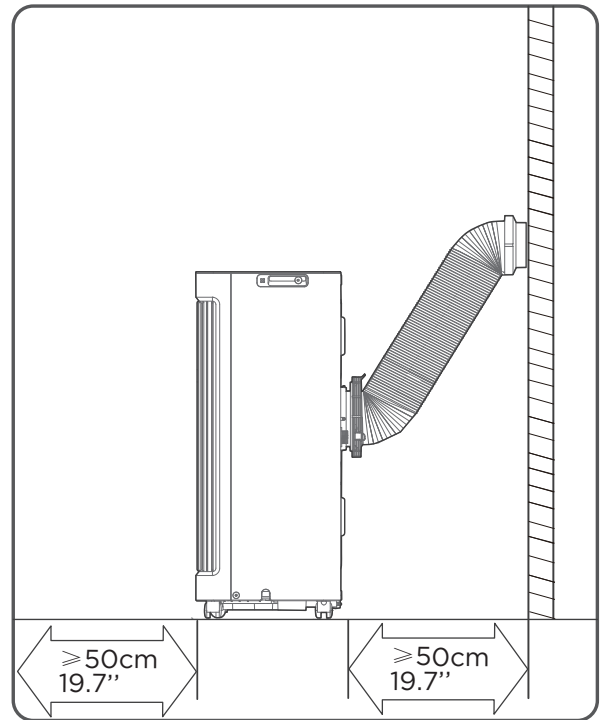
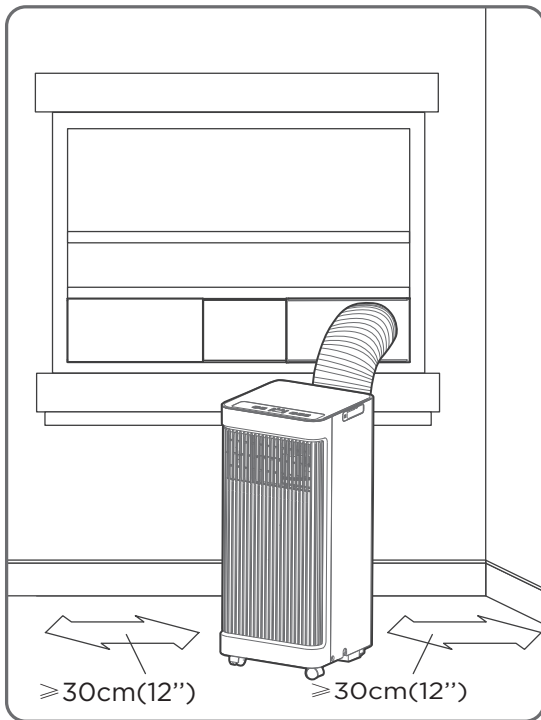

# Product Overview

## NOTE ON ILLUSTRATIONS:

All the illustrations in the manual are for explanation purpose only. Your machine may be slightly different. The actual shape shall prevail. The unit can be controlled by the unit control panel alone or with the remote controller.

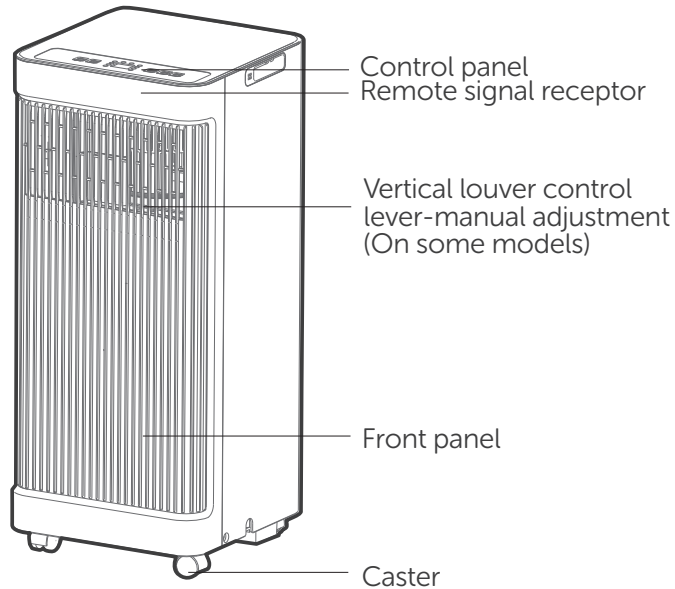

Front View

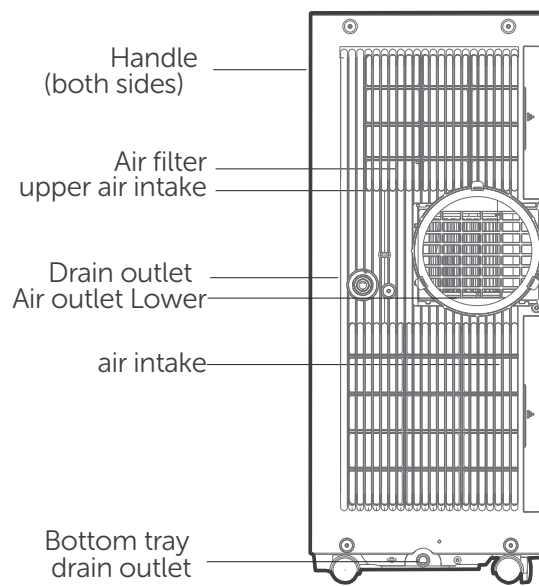

Rear View

## Design Notice

In order to ensure the optimal performance of our products, the design specifications of the unit and remote control are subject to change without prior notice.

# Installation overview

## List of installation tools (not included)



Screwdriver & wrench



Pencil



A tape measure



Scissors or Knife



Saw (On some models, to shorten window adaptor for narrow windows)

## Installation accessories

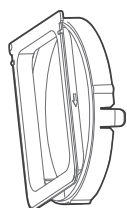

Unit Adaptor (1 pc)

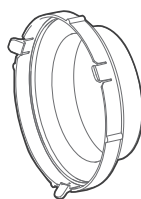

Wall Exhaust Adaptor A  
(only for wall installation models)(1pc\*)



Drain Hose (1 pc)

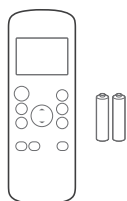

Remote Controller  
and Battery ( 1 set\*)

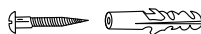

Screw and anchor  
(only for wall installation models) 4 set (\*)

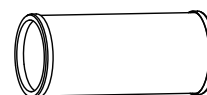

Exhaust Hose (1 pc)



Wall Exhaust Adaptor B  
(with cap)(only for wall installation models)1 pc(\*)

# Installation guide

1

## The Exhaust Hose assembly installation (window type)

Press the exhaust hose(or extended exhaust hose) into the window slider adaptor and unit adaptor, clamp automatically by elastic buckles of the adaptors.



**NOTE:** Please install the exhaust hose assembly according to the fittings in your kit.

Type wall installation:

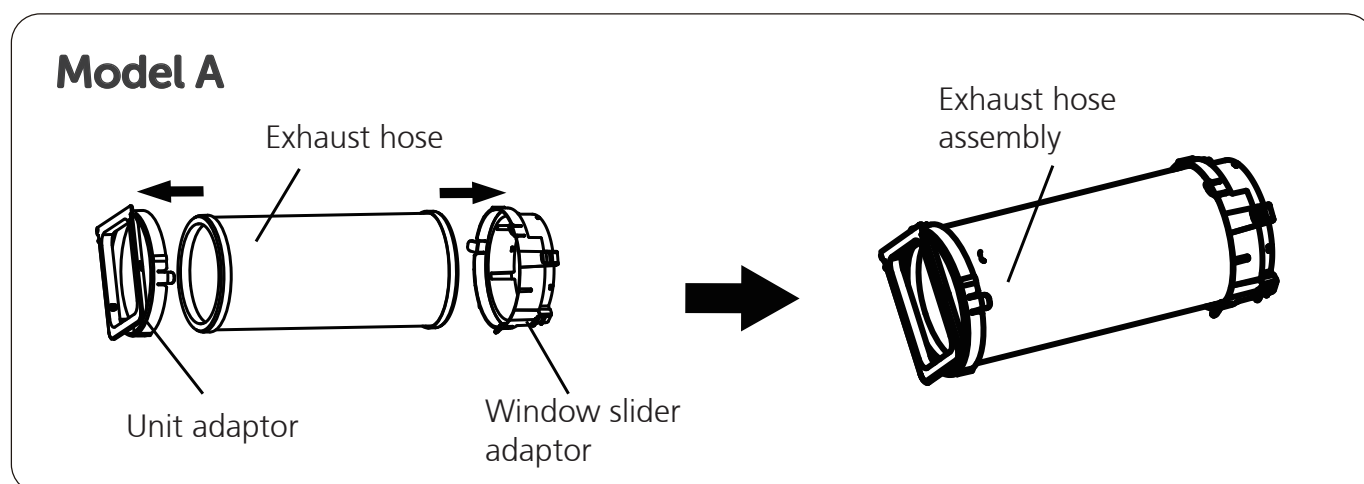

# Wall Installation (wall hole mounted models only)

**NOTE**

Cover the hole using the adaptor cap when not in use.

**Step 1:**

Cut a 125mm (4.9inches) hole into the wall for the Wall Exhaust Adaptor B.

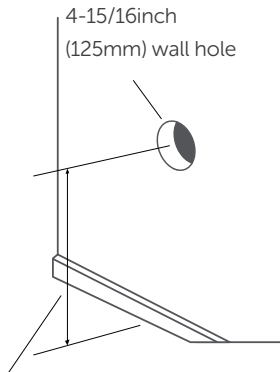

The center of the hole in the wall should be between 80cm (31 inches) and 140cm(55 inches) from the ground.

**Step 2:**

Secure the Wall Exhaust Adaptor B to the wall using the four Anchors and Screws provided in the kit.

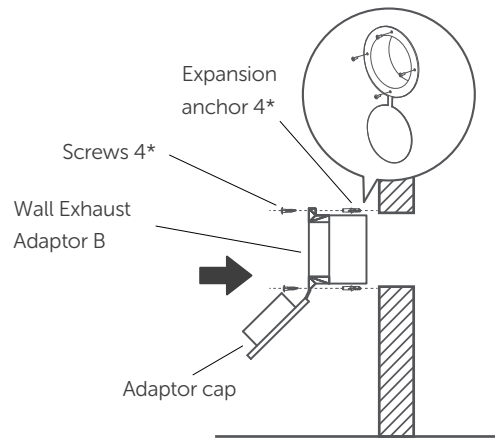

Connect the air hose to the Wall Exhaust Adaptor A first.

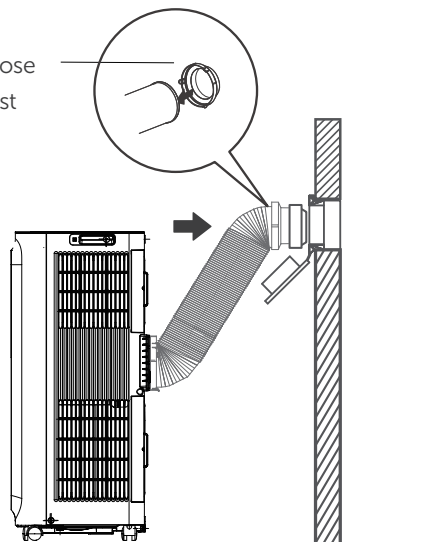

**Step 3:**

Connect the Exhaust Hose Assembly(with Wall Exhaust Adaptor A) to the Wall Exhaust Adaptor B.

**For optimal performance in operation**

INCORRECT

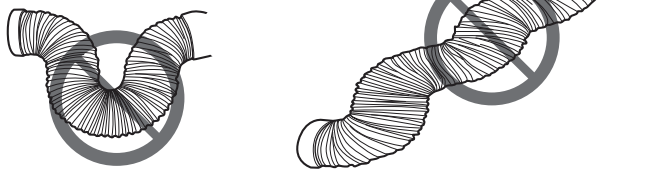

CORRECT

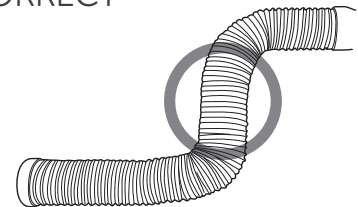

**NOTE:**

To ensure proper function, DO NOT overextend or bend the hose. Make sure that there is no obstacle around the air outlet of the exhaust hose (in the range of 500mm) in order to the exhaust system works properly. All the illustrations in this manual are for explanation purpose only. Your air conditioner may be slightly different. The actual shape shall prevail.

# Get to know your AC

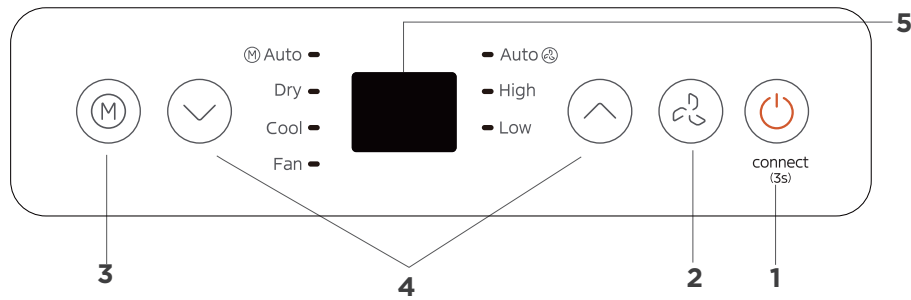

## 1. POWER button

- Press once to turn on; press again to turn off.

## 2. FAN button

Press to control the fan speed in three steps HIGH, LOW, and AUTO. The fan speed indicator light illuminates under different fan settings.

## 3. MODE button

Selects the appropriate operating mode. Each time you press the button, the mode is selected in a sequence that goes from AUTO, DRY, COOL and FAN, The mode indicator light illuminates under the different mode setting.

**NOTE:** In AUTO mode, the FAN speed will be adjusted automatically.

### AUTO mode

Press the "MODE" button until the "Auto" indicator light comes on. In this mode, the fan speed or the temperature will be adjusted automatically.

### COOL mode

Press the "MODE" button until the "COOL" indicator light comes on. Press the UP and DOWN buttons " " or " " to select your desired room temperature. The temperature can be set within a range of 16°C~30°C/60°F~86°F. Press the "FAN " button to choose the fan speed.

### DRY mode

Press the "MODE" button until the "Dry" indicator light comes on. In this mode, the fan speed or the temperature cannot be adjusted. The fan motor operates at Auto speed.

**NOTE:** Keep windows and doors closed for the best dehumidifying effect. Do not put the duct to window.

### FAN mode

Press the "MODE" button until the "FAN " indicator light comes on. Press the "FAN SPEED" button on the remote controller to choose the fan speed. The temperature can not be adjusted. Do not put the duct to window.

#### 4. UP and DOWN buttons

- Used to adjust (increasing/decreasing) temperature settings in 1°C/1°F increments in a range of 16°C/60°F to 30°C/86°F.

**NOTE:** The control is capable of displaying temperature in degrees Fahrenheit or degrees Celsius. To convert from one to the other, press and hold the Up and Down buttons at the same time for 3 seconds.

#### 5. Display

Shows the set temperature while on Cool, or Auto mode. It shows the room temperature on DRY and FAN modes.

**Shows error codes and protection code:**

EH00 - EEPROM error. (PCB memory fault)

EH60-Room temperature sensor error.

EH61-Evaporator temperature sensor error.

EC52-Condenser temperature sensor error (on some models).

EH0b-Display panel communication error.

ELOC-Refrigerant leakage detection malfunction (on some models).

P1-Bottom tray is full. Connect the drain hose and drain the collected water away. If the P1 code does not erase, call for service.

**NOTE:** When one of the above malfunctions occurs, turn off the unit, and check for any obstructions. Restart the unit, if the malfunction is still present, turn off the unit and unplug the power cord. Contact the manufacturer, its service agents or a similar qualified person for service.

## Remote Control

Follow the manufacturer's instructions when installing new batteries.

Only use 'AAA' 1.5V batteries in this remote control.

Slide the back cover from the remote control downward, exposing the battery compartment. Batteries must be placed according to the correct polarity (+ and -). After inserting the batteries, slide the cover back into place.

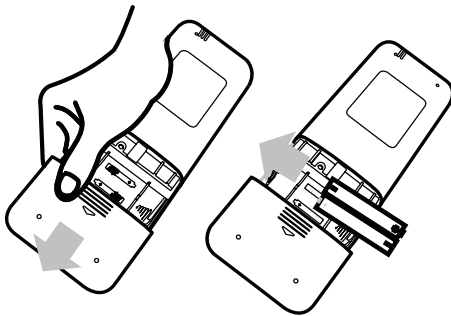

There must be a clear line of sight between the remote and the appliance. If the signals from the remote control happen to control another appliance, move the appliance to another location or contact customer service.

The remote control typically functions within approximately 8 meters from the front of the product, with an allowable deviation angle of up to 30 degrees.

Direct sunlight on the receiving window should be avoided, as it may affect performance.

Handle the remote control carefully, avoiding impacts and drops.

If the remote control will not be used for more than 2 months, remove the batteries and store them.

## ! Battery Disposal

Do not dispose of batteries as unsorted municipal waste. Refer to local laws for proper disposal of batteries.

Batteries may have a chemical symbol at the bottom of the disposal icon. This chemical symbol means that the battery contains a heavy metal that exceeds a certain concentration. An example is Pb: Lead (>0.004%). Appliances and used batteries must be treated in a specialized facility for reuse, recycling and recovery. By ensuring correct disposal, you will help avoid possible negative consequences for the environment and human health.

## Remote buttons & functions

Before you begin using your new air conditioner, make sure to familiarize yourself with its remote control. Full instructions on how the different modes work are found in the 'Getting to know your AC' section of this instruction manual.

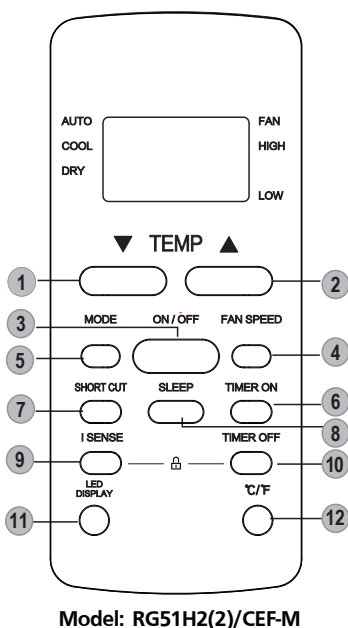

### Temperature

- 1 **TEMP ▼** Decreases temperature in 1°C increments. Min. temperature is 16°C/60°F
- 2 **TEMP ▲** Increases temperature 1°C increments. Max. temperature is 30°C/86°F  
NOTE: Press and hold both temp buttons at the same time for 3 seconds to switch between °C to °F
- 3 **ON/OFF:** Turns the unit on or off.
- 4 **FAN SPEED:** Selects fan speeds in the following order:  
**AUTO - LOW -HIGH**
- 5 **MODE:** Scrolls through operation modes as follows:  
**AUTO - COOL- DRY- FAN**
- 6 **TIMER ON:** Sets timer to turn unit on
- 7 **SHORT CUT:** Sets and activates your favorite pre-settings.
- 8 **SLEEP:** Saves energy during sleeping hours .
- 9 **I SENSE:** Temperature sensing and room temperature display button.
- 10 **TIMER OFF:** Sets timer to turn unit off.
- 11 **LED DISPLAY:** Press this button to turn on and turn off the display on the unit.
- 12 **REMOTE LOCK:** Press together the two buttons simultaneously for 5 seconds to lock the keyboard. Press together the two buttons for 2 seconds to unlock the keyboard.





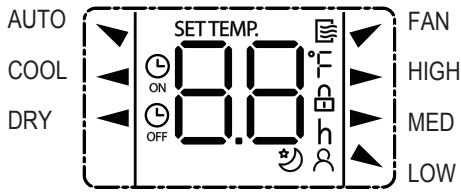



## Remote Screen Indicators

Information that is displayed when the remote controller is in use. Please note, all indicators shown below are for the purpose of clear presentation. During actual operation, only the relative function sign will be shown on the display window.





### Mode display



- 
-  Displayed when data transmitted.
  -  Displayed when remote controller is ON.
  -  Displayed when TIMER ON time is set
  -  Displayed when TIMER OFF time is set
  -  Shows set temperature or room temperature, or time under TIMER setting
  -  Indicated all the current settings are locked
  -  Displayed when I SENSE feature is activated(some units)
  -  Displayed when SLEEP feature is activated

---

### Fan speed indication

-  HIGH High speed
  -  MED Medium speed(some units) Low speed
  -  LOW speed
  - NO display Auto fan speed
-

# How to Use Basic Functions

**!** Before operation, please ensure the unit is plugged in and power is available.

## AUTO Mode

Select AUTO mode

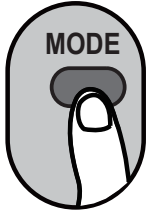

Set your desired temperature

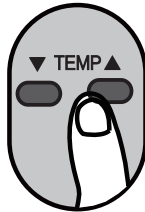

Turn on the air conditioner

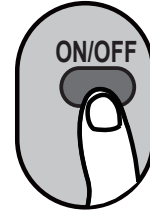

### NOTE:

1. In AUTO mode the unit will automatically select the COOL, FAN, or HEAT function based on the set temperature.
2. In AUTO mode, fan speed cannot be set.

## COOL or HEAT Mode

Select COOL/HEAT mode

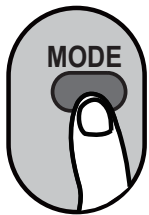

Set the temperature



Set the fan speed



Turn on the air conditioner



## DRY Mode

Select DRY mode

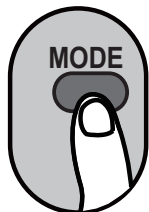

Set your desired temperature

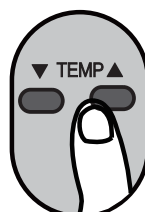

Turn on the air conditioner

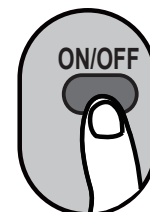

NOTE: In DRY mode, fan speed can not be set since it has already been automatically controlled.

## FAN Mode

Select FAN mode

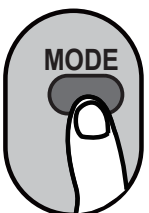

Set the fan speed



Turn on the air conditioner



NOTE: In FAN mode, you can't set the temperature. As a result, no temperature displays in remote screen.

## Setting the TIMER

TIMER ON/OFF - Set the amount of time after which the unit will automatically turn on/off.

### TIMER ON setting

Press TIMER ON button to initiate the ON time sequence.

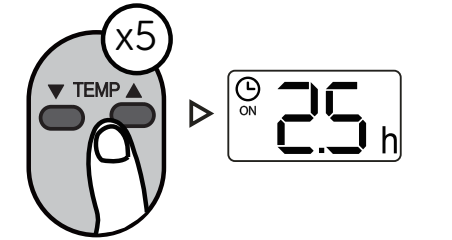

Point remote to unit and wait 1sec, the TIMER ON will be activated.

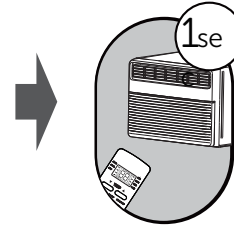

### TIMER OFF setting

Press TIMER OFF button to initiate the OFF time sequence.



Press Temp. up or down button for for multiple times to set the desired time to turn off the unit.

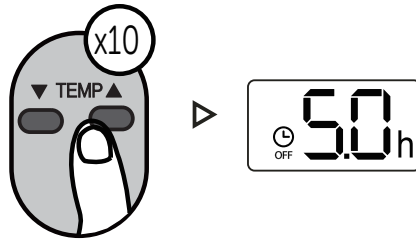

Point remote to unit and wait 1sec, the TIMER OFF will be activated.

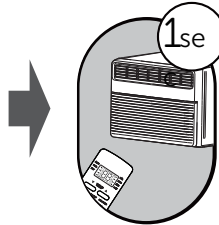

#### NOTE:

- When setting the TIMER ON or TIMER OFF, the time will increase by 30 minutes increments with ea press, up to 10 hours. After 10 hours and up to 24, it will increase in 1 hour increments. (For example, press 5 times to get 2.5h, and press 10 times to get 5h,) The timer will revert to 0.0 after 24.
- Cancel either function by setting its timer to 0.0

### TIMER ON & OFF setting (example)

Keep in mind that the time periods you set for both functions refer to hours after the current time.

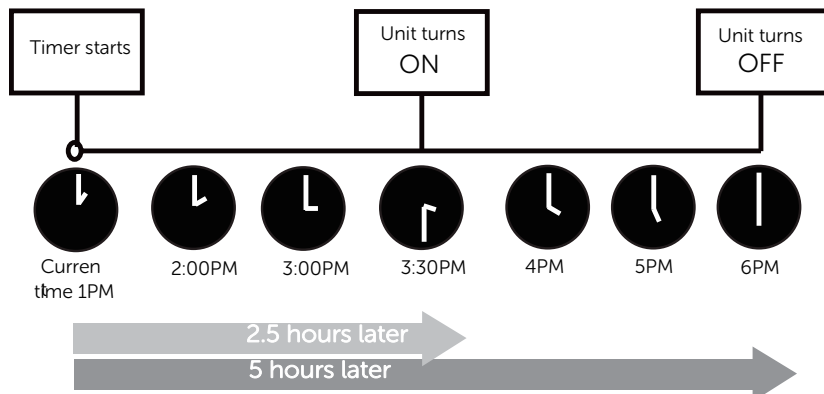
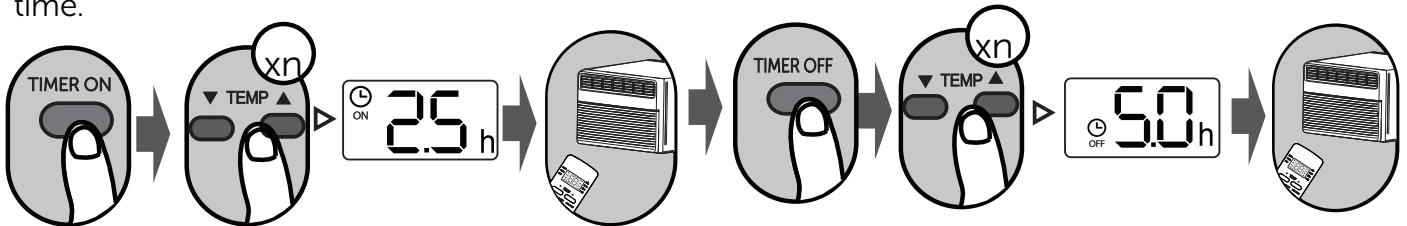

Example: If current timer is 1:00PM, to set the timer as above steps, the unit will turn on 2.5h later (3:30PM) and turn off at 6:00PM.

# How to Use Advanced Functions

## SLEEP function



The SLEEP function is used to decrease energy use while you sleep (and don't need the same temperature settings to stay comfortable). This function can only be activated via remote control. The sleep function is not available in Fan or Dry mode. Please refer to the OWNER'S MANUAL for more details.

## I SENSE function(some units)

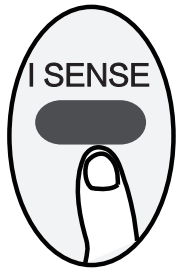

When the I SENSE function is activated, the remote display is actual temperature at its location. The remote control will send this signal to the air conditioner every 3 minutes interval until press the I SENSE button again.

**NOTE:** Press this button for seven seconds to start/stop memory feature of I SENSE function.

- If the memory feature is activated, **ON** displays for 3 seconds on the screen.
- If the memory feature is stopped **OFF** displays for 3 seconds on the screen.
- Whilst the memory feature is activated, press the ON/OFF button, shift the mode or power failure will not cancel the I SENSE function.

## SHORTCUT function(some units)



Push this button when remote controller is on, the system will automatically revert back to the previous settings including operating mode, setting temperature, fan speed level and sleep feature(if activated).

If pushing more than 2 seconds, the system will automatically restore the current operation settings including operating mode, setting temperature, fan speed level and sleep feature (if activated).

Used to restore the current settings or resume previous settings.

# Drainage guide

During dehumidifying mode, remove the upper drain plug from the back of the unit, install a drain connector (5/8" universal female mender, not included), and attach to a garden hose (not included). Place the open end of the hose directly over the drain area or place it into a bucket.

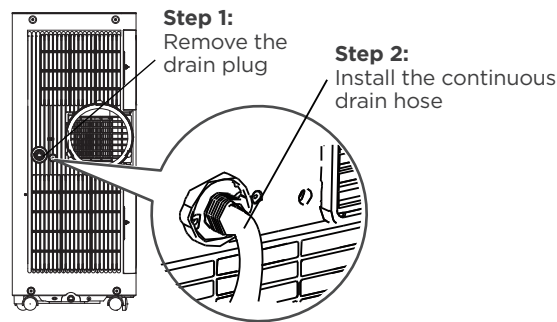

## NOTE:

Make sure the hose is secure so there are no leaks. Direct the hose towards the drain, making sure that there are no kinks that will stop the water flowing. Place the end of the hose into the drain and make sure the end of the hose is facing downwards to allow for smooth water flow. The end of the drain hose cannot be facing upwards. When the continuous drain hose is not used, ensure that the corresponding drain plug is installed firmly to prevent leakage.

When the water level of the bottom tray reaches a predetermined level, the unit beeps 8 times, the digital display area shows "P1". At this time the air conditioning/dehumidification process will immediately stop. However, the fan motor will continue to operate (this is normal). Carefully move the unit to a drain location, remove the bottom drain plug and let the water drain away. Reinstall the bottom drain plug and restart the machine until the "P1" symbol disappears. If the error repeats, call for service.

## NOTE:

Make sure the end of the hose is lower than the bottom train drain outlet. Be sure to reinstall the bottom drain plug firmly to prevent leakage before using the unit.

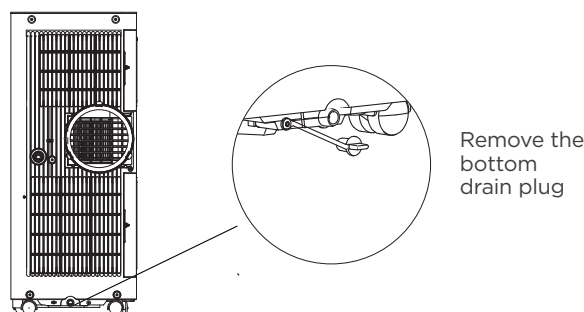

# Cleaning and Maintenance

## Air Filter & Cabinet Cleaning

Clean the unit using a damp, lint-free cloth and mild detergent. Dry the unit with a dry, lint-free cloth.

### Removal

Take the filter out along the arrow direction.

### Cleaning

Wash the air filter by immersing it gently in warm water water (about 40°C/104°F) with a neutral detergent. Rinse the filter and dry it in a shady place.

## Maintenance Tips

Be sure to clean the air filter every 2 weeks for optimal performance.

The water collection tray should be drained immediately after P1 error occurs, and before storage to prevent mould.

In households with animals, you will have to periodically wipe down the grill to prevent blocked airflow due to animal hair.

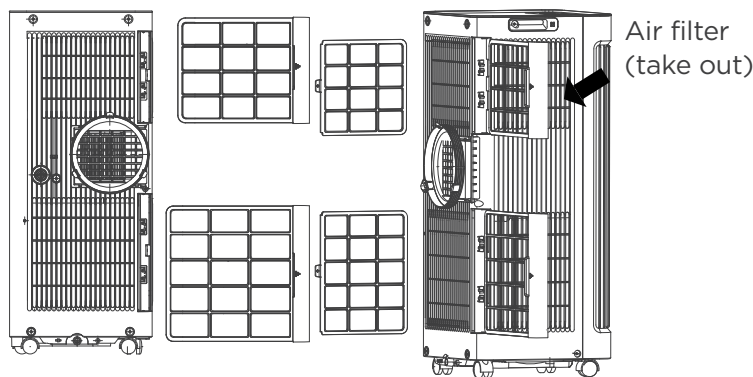

**Remove the air filter**

### CAUTION:



- Always unplug the unit before cleaning or servicing.
- DO NOT use flammable liquids or chemicals to clean the unit.
- DO NOT wash the unit under running water. Doing so causes electrical danger.
- DO NOT operate the machine if the power supply was damaged during cleaning. A damaged power cord must be replaced with a new cord from the manufacturer.
- DO NOT operate the unit without filter because dirt and lint will clog it and reduce performance.

# Storing the unit when not in use

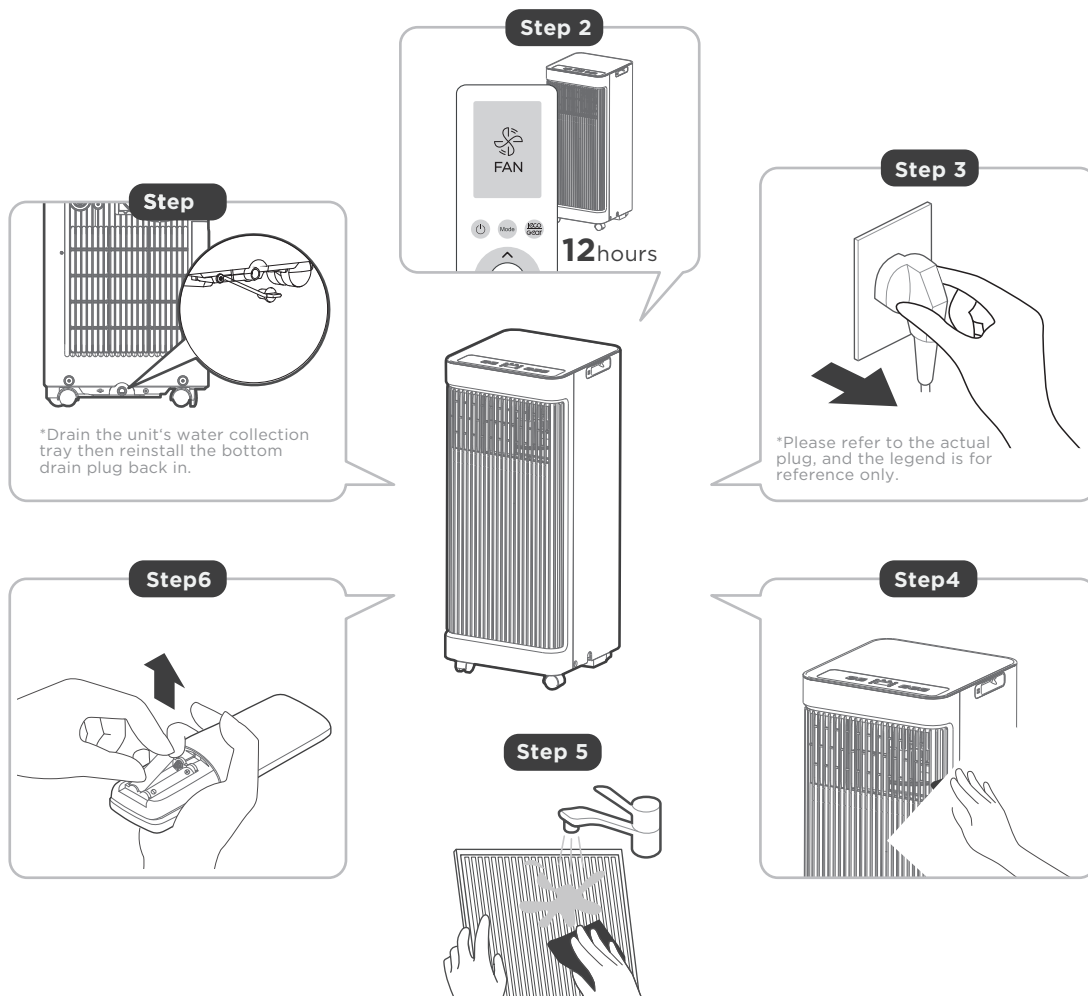

- Drain the unit's water collection tray according to the instructions in the following section.
- Run the appliance on FAN mode for 12 hours in a warm room to dry it and prevent mold.
- Turn off the appliance and unplug it.
- Clean the air filter according to the instructions in the previous section. Reinstall the clean, dry filter before storing
- Remove the batteries from the remote control.

## NOTE

- Be sure to store the unit in a cool, dark place. Exposure to direct sunshine or extreme heat can shorten the lifespan of the unit.
- The cabinet and front may be dusted with an oil-free cloth or washed with a cloth dampened in a solution of warm water and mild liquid dishwashing detergent. Rinse thoroughly and wipe dry. Never use harsh cleansers, wax or polish on the cabinet front. Be sure to wring excess water from the cloth before wiping around the controls. Excess water in or around the controls may cause damage to the unit.

# Troubleshooting

## Common Issues

The following problems are not a malfunction and in most situations will not require repairs.

Problem	Possible Causes	Solution
Unit does not turn on when pressing ON/OFF button	P1 Protection Code	The Water Collection Tray is full. Turn off the unit, drain the water from the Water Collection Tray and restart the unit.
	In COOL mode: room temperature is lower than the set temperature.	Reset the temperature.
Unit does not cool well	The air filter is blocked with dust or animal hair.	Turn off the unit and clean the filter according to instructions.
	Exhaust hose is not connected or is blocked.	Turn off the unit, disconnect the hose, check for blockage and reconnect the hose.
	The unit is low on refrigerant.	Call a service technician to inspect the unit and top off refrigerant.
	Temperature setting is too high.	Decrease the set temperature.
	The windows and doors in the room are open.	Make sure all windows and doors are closed.
	The room area is too large.	Double-check the cooling area.
The unit is noisy and vibrates too much	There are heat sources inside the room.	Remove the heat sources if possible.
	The ground is not level.	Place the unit on a flat, level surface.
The unit makes a gurgling sound	The air filter is blocked with dust or animal hair.	Turn off the unit and clean the filter according to instructions.
	This sound is caused by the flow of refrigerant inside the unit.	This is normal.

## Technical Specifications

<b>BUSH 7K AIR CONDITIONER</b>	Symbol	Value	Unit
Model number	--	MPPA-07CRN7-QB6(A)	--
Power Input	--	220-240	VAC
Insulation Class	⊖	I	(earthed)
Cooling Capacity		7000	Btu/hr
Rated capacity for cooling	$P_{rated}$	2.0	kW
Rated power input for cooling	$P_{EER}$	0.8	kW
Rated energy efficiency ratio	$EERd$	2.6	
Power consumption in standby mode - no display	$P_{SB}$	0.5	W
Fan sound level Low / High		52.7/54.5	dB(A)
Sound power level at standard rating conditions	$LWA$	63	dB(A)
Electricity consumption of single duct appliances (indicate for cooling and heating separately) *	$SD: Q_{SD}$	SD: 0.8	SD: kWh/h
Maximum air flow volume	C	327	Meters <sup>3</sup> /hr
Refrigerant Type / Weight	R290	R290 / 0.11	kg
Energy efficient class in cooling		A	
Bush Careline	Customer helpline 0345 604 0105		

\*Energy consumption 0.8 kWh per 60 minutes in cooling mode, based on standard test results. Actual energy consumption will depend on how the appliance is used and where it is located.

<b>BUSH 9K AIR CONDITIONER</b>	Symbol	Value	Unit
Model number	--	MPPA-09CRN7-QB6(A)	--
Power Input	--	220-240	VAC
Insulation Class	⊖	I	(earthed)
Cooling Capacity		9000	Btu/hr
Rated capacity for cooling	$P_{rated}$	2.6	kW
Rated power input for cooling	$P_{EER}$	1	kW
Rated energy efficiency ratio	$EERd$	2.6	
Power consumption in standby mode - no display	$P_{SB}$	0.5	W
Fan sound level Low / High		53.9/54.8	dB(A)
Sound power level at standard rating conditions	$LWA$	64	dB(A)
Electricity consumption of single duct appliances (indicate for cooling and heating separately) *	$SD: Q_{SD}$	SD: 1	SD: kWh/h
Maximum air flow volume	C	332	Meters <sup>3</sup> /hr
Refrigerant Type / Weight	R290	R290 / 0.16	kg
Energy efficient class in cooling		A	
Bush Careline	Customer helpline 0345 604 0105		

\*Energy consumption 1.0 kWh per 60 minutes in cooling mode, based on standard test results. Actual energy consumption will depend on how the appliance is used and where it is located.



## Disposal And Recycling of electrical products

Compliance with the WEEE Directive and Disposing of the Waster Product:

This product complies with EU WEEE Directive. This product bears a classification symbol for waste electrical and electronic equipment (WEEE).

You should now recycle your waste electrical goods and in doing so help the environment. This symbol means an electrical product should not be disposed of with normal household waste. Please ensure it is taken to a suitable facility for disposal. Visit [www.recycle-more.co.uk](http://www.recycle-more.co.uk), click on "bank locator" and enter your postcode to find your nearest recycling site.



## Product support



### Help and assistance

If you require any technical guidance or find that your Fan is not operating as intended, a simple solution can often be found in these instructions or online at [www.bush-support.com](http://www.bush-support.com)

If you still require further assistance, call one of our experts on 0345 604 0105\*. To help give us give you a fast and efficient service please have the following information ready:

Model Ref.

You can find these on the rating plate - a small information panel (usually as ticker or metal plate) on the rear of your product.

Serial number

This will be shown on your receipt

Date of purchase

Local call rates apply\*

**Lines open 8am-7pm Monday to Saturday and 10am-4pm Sunday.**

\*Calls to Bush enquiry lines may attract a charge and set up fee from residential lines depending on your call plan/tariff. Mobile and other providers costs may vary, see [www.bt.com/pricing](http://www.bt.com/pricing) for details.

For security and training purposes, telephone calls to and from customer service centres may be recorded and monitored. Calls from Republic of Ireland will attract international call charges.



## Product support

Help is always at hand



Call us now and register your 12 month guarantee

Thank you for choosing Bush. Your new product is guaranteed against faults and breakdowns for 12 months. Don't forget to register it with us today so we can provide you with our best possible after-sales service and useful updates.

[www.bushregistration.co.uk](http://www.bushregistration.co.uk)

FREEPHONE\*

0800 597 8548

Lines are open 8am - 8pm, 365 days a year. \*Calls may be recorded and monitored.

### Your Bush Guarantee

This product is guaranteed for twelve months from the date of original purchase. Any defect that arises due to faulty materials or workmanship will be repaired free of charge (or if applicable the product will be replaced or the purchase price refunded) where possible during this period by the dealer from whom you purchased the unit.

The guarantee is subject to the following provisions:

- The guarantee does not cover accidental damage, misuse, cabinet parts, knobs or consumable items.
- The product must be correctly installed and operated in accordance with the instructions contained in the manual.
- It must be used solely for domestic purposes. The guarantee will be rendered invalid if the product is re-sold or has been damaged by inexpert repair.
- Specifications are subject to change without notice.
- Bush disclaim any liability for loss or damage arising from the breakdown of the product.
- This guarantee is in addition to and does not diminish your statutory or legal rights.

### Important Data Protection Information

To find out how we and Domestic & General Insurance Plc use your data please refer to the guarantee registration material or visit [www.bushregistrations.co.uk](http://www.bushregistrations.co.uk)

Guarantor: Argos Limited, Sainsbury's Supermarkets Ltd, London, EC1M 6HA, UK  
.Argos (N.I.) Ltd, and Sainsbury's (NI) Ltd, Forestside Shopping Centre,  
UpperGalwally, Belfast, BT8 6FX, UK.

