

HISENSE A6 SERIES USER MANUAL



Quick Links

[First-Time Use](#)

[Using External Devices](#)

Table of Contents

[Table of Contents](#)

[First-Time Use](#)

[Using the E-Manual](#)

[Home Screen](#)

[Connect to the Internet](#)

[Prepare Live TV](#)

[Using External Devices](#)

[Using the TV Voice Service](#)

[Recommended Topics](#)

[Enjoy Live TV](#)

[Channel Scan](#)

[Live Menu](#)

[Channel Edit](#)

[Benefits of Smart TV](#)

[Using a VIDAA Account](#)

[Voice Service Setup](#)

[Content Sharing](#)

[Using Apps](#)

[Using the Art App](#)

[Enjoy the Internet](#)

[Set Usage Mode](#)

[Using the Mobile App](#)

[Connecting to External Devices](#)

[Remote & Accessories](#)

[Connecting Bluetooth Devices](#)

[Connecting a Set Top Box](#)

[Connecting a Blu-ray or DVD Player](#)

[Sharing your Smart Phone/Computer Screen on the TV](#)

[Using AirPlay and HomeKit](#)

[Connecting USB Devices](#)

[Connecting Headphones](#)

[Connecting Audio Visual \(AV\) Devices](#)

[Connecting Speakers or Other Audio Receivers](#)

[Connecting a Digital Audio System with ARC](#)

[Connecting a PC](#)

[Settings Overview](#)

[Picture](#)

[Sound](#)

[Network](#)

[General](#)

[Support](#)

[Using Parental Controls](#)

[Reset to Factory Default](#)

[Entertainment](#)

[Game](#)

[Sports](#)

[Media](#)

[SoundBar Settings](#)

[Accessibility Features](#)

[Accessibility Settings](#)

[Troubleshooting](#)

[FAQ](#)

TV Status Diagnosis

Picture Issues

Sound Issues

Network Issues

Channel and Broadcast Issues

External Device Connection Issues

HDMI & CEC Issues

Application Issues

Media Files

Voice Service Issues

Other Issues

Other ManualsLib Projects

USER MANUAL

Before using the TV, please read this manual thoroughly and retain it for future reference.

ENGLISH

FRANÇAIS

ESPAÑOL

USER MANUAL

Before using the TV, please read this manual thoroughly and retain it for future reference.

Contents

First-Time Use

Using the E-Manual.....	3
Home Screen.....	3
Connect to the Internet.....	4
Prepare Live TV.....	6
Using External Devices.....	7
Using the TV Voice Service.....	7
Recommended Topics.....	8

Enjoy Live TV

Channel Scan.....	9
Live Menu.....	9
Channel Edit.....	11

Benefits of Smart TV

Using a VIDAA Account.....	13
Voice Service Setup.....	13
Content Sharing.....	15
Using Apps.....	16
Using the Art App.....	17
Enjoy the Internet.....	18
Set Usage Mode.....	19
Using the Mobile App.....	19

Connecting to External Devices

Remote & Accessories.....	21
Connecting Bluetooth Devices.....	22
Connecting a Set Top Box.....	24
Connecting a Blu-ray or DVD Player.....	24
Sharing your Smart Phone/Computer Screen on the TV.....	24
Using AirPlay and HomeKit.....	25
Connecting USB Devices.....	26
Connecting Headphones.....	27
Connecting Audio Visual (AV) Devices.....	27
Connecting Speakers or Other Audio Receivers.....	28
Connecting a Digital Audio System with ARC.....	29
Connecting a PC.....	29

Settings Overview

Picture.....	31
Sound.....	34

Contents

Network.....	37
General.....	38
Support.....	41
Using Parental Controls.....	42
Reset to Factory Default.....	43

Entertainment

Game.....	44
Sports.....	44
Media.....	45
SoundBar Settings.....	47

Accessibility Features

Accessibility Settings.....	49
-----------------------------	----

Troubleshooting

FAQ.....	51
TV Status Diagnosis.....	58
Picture Issues.....	58
Sound Issues.....	59
Network Issues.....	60
Channel and Broadcast Issues.....	60
External Device Connection Issues.....	61
HDMI & CEC Issues.....	61
Application Issues.....	61
Media Files.....	62
Voice Service Issues.....	62
Other Issues.....	62

First-Time Use

Using the E-Manual

View the embedded E-Manual that contains information about your TV's key features.

Disclaimer:

Instructions and images through this manual are only for reference and may differ from the actual product.

Launch the E-Manual

 > My Apps > E-Manual

- The black background icon stands for the button on the remote.
- The grey background icon stands for the icons on the TV screen for selecting.

Use the Buttons in the E-Manual

Search

Search for the product feature information, the E-Manual will provide all the titles and content that contains the search information.

QR Code

Scan the QR Code with your Smart Phone to open the E-Manual on your device.

Try Now button

Select **Try Now**, and it will guide you to the corresponding TV menu for trying the function.

Home Screen

All TV functions can be accessed from the Home screen.

Display the Home Screen

Press  button on your remote to enter the Home screen.

To exit the Home screen, press  button on your remote or use the navigation buttons to move the cursor to the  **Input** icon on the top of the screen, press  button to enter and select your desired input source.

Use the Navigation Bar

The navigation bar refers to indicators and icons on the top of the Home screen.

Note:

- Indicators or icons may vary depending on models/countries/regions.

 **Search**

Search the content you want.

 **Input**

Select the input source depending on the device you have connected to your TV.

 **Settings**

First-Time Use

Manage TV configuration.

Notifications

Allow pop-up notifications to appear for useful information and events that occur with your TV, including: **Advertising, New Arrivals, Warnings and Legal Statements, System Messages** and **Alexa Notification**. You can enable/disable each of these notifications at Settings in the notification centre.

You can view the list of event messages generated by the TV.

To delete all notifications, select **Clear All**.

Note:

- The Alexa Notification may not be applicable in some models/countries/regions.
- When you sign into your VIDAA account, please find Notifications in VIDAA Account on the Home screen.

VIDAA Account

Sign into your VIDAA account.

A VIDAA account provides all the best features of your Smart TV and ensures that all services are kept up to date.

For more information about VIDAA account, please refer to [Benefits of Smart TV > Using a VIDAA Account](#) in this manual.



Voice

Quick access to **Voice Service**. For more information, please refer to [Benefits of Smart TV > Voice Service Setup](#) in this manual.

Time

You can always view the current time at the top of the Home screen.

Network

Connect your TV to the Internet through a wireless connection  or an Ethernet cable  , and the corresponding icon will appear.

Connect to the Internet

To get access to the Internet using a wired connection (some models don't support wired connection) or connecting to an available wireless network.

Connect to a Wired (Ethernet) Network

Note:

- This function may not be applicable in some models/countries/regions.

To get access to the Internet using a wired connection, it is recommended to use a modem or router that supports Dynamic Host Configuration Protocol (DHCP). Modems and routers that support DHCP automatically provide the IP address, netmask, gateway, DNS Server 1 and DNS Server 2, so you do not have to enter them manually. Most home networks already have DHCP.

See the illustration below.

First-Time Use

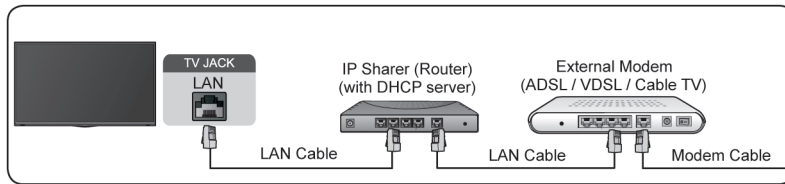

After connecting to a wired (Ethernet) network:

> **Settings** > **Network** > **Network Configuration**

Set the TV network by selecting **Network Configuration** and press button to enter the submenu.

- **Connection Type**

Choose a wired (Ethernet) network connection to access the Internet.

- **Ethernet**

Display network status.

- **IP Settings**

Configure the IP setting for your network connection.

Related information

[Network](#) on page 37

[Network Issues](#) on page 60

[My TV cannot connect to the network.](#) on page 53

Connect to a Wireless Network

To connect to an available wireless network, make sure that you turn on your wireless router and have the wireless router's SSID and password before attempting to connect.

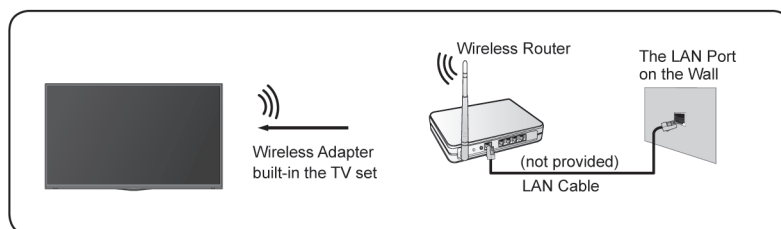

To get access to the Internet using a wireless connection:

> **Settings** > **Network** > **Network Configuration**

Set the TV network by selecting **Network Configuration** and press button to enter the submenu.

- **Connection Type**

Choose a wireless network connection to access the Internet.

- **Advanced Settings**

Configure the advanced wireless network settings for the TV.

First-Time Use

- **Add**

You can add a wireless network.

- **Refresh**

Refresh wireless network.

Note:

- If no wireless router is found, select **Add** and enter the network name in the SSID.
- If no wireless router is found, select **Refresh**.

 **Related information**

[Network](#) on page 37

[Network Issues](#) on page 60

[My TV cannot connect to the network.](#) on page 53

Internet Related Features

- Content Sharing

To view media content, like videos, music or photos saved in your Android/iOS/PC device on your TV screen. For more information, please refer to [Benefits of Smart TV > Content Sharing](#) in this manual.

- Sharing your Smart Phone/Computer Screen on the TV

To mirror your mobile device or computer screen to the TV. For more information, please refer to [Connecting to External Devices > Sharing your Smart Phone/Computer Screen on the TV](#) in this manual.

Prepare Live TV

Connect antenna/cable to the TV

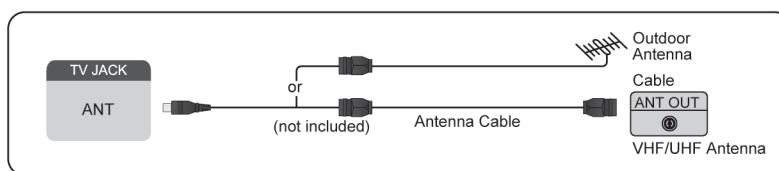

Note:

- TV jacks may vary and antenna/cable function may not be applicable in some models/countries/regions.
- You may also connect devices that can receive broadcast signals such as a Set Top Box.

Start auto scan or manual scan



1.  > TV.
2.  > Settings > Channels > Auto Channel Scan

 **Related information**

[Channel Scan](#) on page 9





Using External Devices

Switch between external devices connected to the TV



1. Press  button on your remote or use the navigation buttons to move the cursor to the  **Input** icon on the top of the Home screen, press  button to enter.
2. Select your desired input source.

Edit the name of input sources

Method 1:

1. Press  button on your remote or press  button to move the cursor to the  **Input** icon on the top of the Home screen, press  button to enter.
2. Move the cursor to an input source and press  button on your remote.
3. Select **Rename**.

Method 2:

Access  >  **Settings** > **System** > **Advanced Settings** > **Input Names** to edit the name of input sources.





Note:

- Some input sources cannot be renamed.

Using the TV Voice Service

Select Voice Service on the TV

To access the Voice Service and select a voice assistant:

- press  button on your remote and select  **Voice** icon in the navigation bar;
- or press  button on your remote;
- or press  button to select  **Settings** icon, and select **System** > **Voice Service**.

Use the remote microphone

You can enjoy interacting with voice assistant using your voice by just pressing and holding the  button on your remote.

Note:

- Voice Service feature may not be applicable in some models/countries/regions.
- To use this function, End User License Agreement and corresponding Smart feature privacy policy/terms and conditions may be required to be agreed to.

Related information

[Voice Service Setup](#) on page 15

Recommended Topics

Install an App from App Store

Install apps from App Store for your entertainment preferences. For more information, please refer to [Benefits of Smart TV > Using Apps > Install an App from App Store](#) in this manual.

Picture

Adjust picture mode, picture size and other advanced picture settings. For more information, please refer to [Picture and Sound > Picture](#) in this manual.

Sound

Adjust sound mode and other advanced sound settings. For more information, please refer to [Picture and Sound > Sound](#) in this manual.

Keep the TV updated

Set your TV to receive the latest firmware. For more information, please refer to [Settings Overview > Support > System Upgrade](#) in this manual.

Channel Scan

You can scan for channels automatically or manually.

Note:

Antenna/cable function may not be applicable in some models/countries/regions.

Auto Scan

If no TV channels were saved before, you will be prompted to do a channel search.

Automatically scan for channels to view programmes from your TV source.

 > **Settings** > **Channels** > **Auto Channel Scan**

Notice:

- Before you select Automatic Scan, you can press  > **Settings** > **Channels** > **Tuner mode** to select **Antenna** or **Cable**.

Manual Scan

Manually scan for channels.

 > **Settings** > **Channel** > **Add A Channel**

Enter a cable (1-35) or broadcast (2-69) channel number to manually add it to Channel List.

Live Menu

You can obtain quick access to the channel list, favorite channel list or use relevant features with ease when watching TV programmes.

Display Channel List

In Live TV, press  button on the remote to display the channel list menu.

Learn about channel list sub-menu

In Live TV, press  button on the remote control to display the channel list menu.

Enjoy Live TV



- **TV List**

Display Live TV channel categories, such as **Cable** and **Antenna**.

- **Favorite**

Displays favorites lists.

- **History**

Display the channels that have been watched for a period of time.

Note:

- The sub-menu options may vary depending on models/countries/regions.

Display Favorite Channel List

In Live TV, press **OK** > **>** > **V** to select **Favorite**, and press **OK** button to display the favorite list.

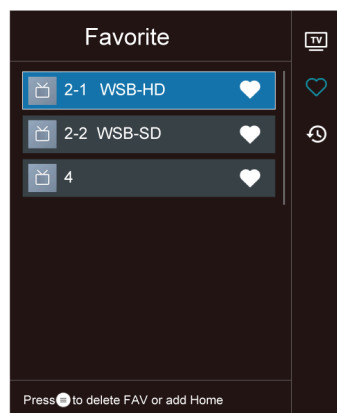

Note:

- These steps should be operated under TV inputs.

Related information

[Edit Favourite Channel List](#) on page 11

Channel Edit

Manually edit the channel list or favorite channel list to your preference.

Edit Channel List

Before you can edit the channel list, Channel Scan must be completed first.

In Live TV, you can add channels from various reception types to the favorite list. Also you can add channels from various reception types to home.



Add a channel to home

You can add channels from various reception types to home, you can use it expediently.

1. In Live TV, press **OK** button to display the channel list.
2. Press **Menu** button, select the channel(s) you want to add to the favorite list by pressing **OK** button.
3. Press **Left Arrow** button to select **Add to home**.
4. Press **OK** button to confirm.
5. Then the channel will appear on home page.

Edit Favorite Channel List

Before you can edit the favorite list, Channel Scan must be completed first.

Add a channel to a favorite list

You can add channels from various reception types to the favorite list.

1. In Live TV, press **OK** button to display the channel list.
2. Press **Menu** button, select the channel(s) you want to add to the favorite list by pressing **OK** button.
3. Press **Left Arrow** button to select **Add to Favorite**.
4. Press **OK** button to confirm.
5. Then a heart-shape icon will appear next to the added channel.

Enjoy Live TV

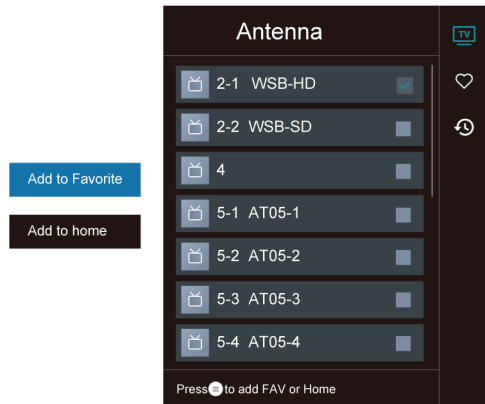

Move or remove channels in a favorite list

If you want to remove favorite channels:

1. In Live TV, press **OK** > **→** > **▼** to select **FAV**, and press **OK** button to display the favorite list.
2. Press **≡**, select the channel(s) you want to delete to the favorite list by pressing **OK** button.
3. Press **←** button to select **Delete Fav. Channel**.
4. Press **OK** button to confirm.
5. Then the channel you select will disappear on the FAV list.

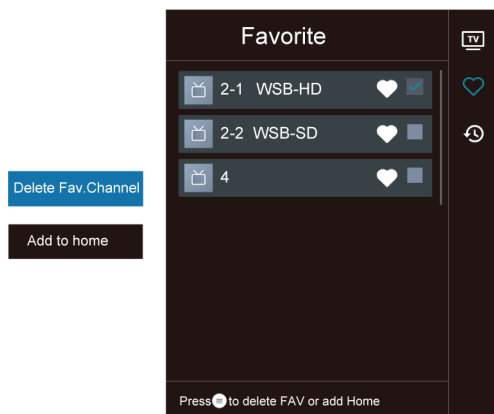

Note:

- These steps should be operated under TV inputs.
- Before you edit the favorite lists, complete channel scan first.

≡ Related information



[Channel Scan](#) on page 9

Benefits of Smart TV

Using a VIDAA Account

Sign into an account



Before signing into your VIDAA account, make sure your TV is connected to the network. For more about network settings, please refer to [First-Time Use > Connect to the Internet > Connect to a Wired \(Ethernet\) Network](#) or [Connect to a Wireless Network](#) in this manual.

1. After the network is connected, press  button on your remote and select  **VIDAA Account** icon in the top navigation bar on the Home screen.
2. Register your device to your VIDAA Account. After entering your E-mail and password, select **Sign In**.

Create a new account

If you do not have a VIDAA account, create a new one to enjoy the best features of your Smart TV.

Before creating a new account, make sure your TV is connected to the network. For more about network settings, please refer to [First-Time Use > Connect to the Internet > Connect to a Wired \(Ethernet\) Network](#) or [Connect to a Wireless Network](#) in this manual.

1. After the network is connected, press  button on your remote and select  **VIDAA Account** icon in the top navigation bar on the Home screen.
2. Select **Create an Account** on screen.
3. Enter your first name, last name, E-mail address and password. First Name and Last Name are optional.
4. Select **Create an Account**.

Voice Service Setup



Set up voice assistant to control your TV just by your voice.

Note:



- Voice Service feature may not be applicable in some models/countries/regions.
- To use this function, End User License Agreement and corresponding Smart feature privacy policy/terms and conditions may be required to be agreed to.

Alexa Setup

Set up Alexa, and enjoy Alexa voice service. You can ask for information, streaming music, search for your favorite movies, control your TV and more, just by asking Alexa.

Before setting up the Amazon Alexa Service, connect your TV to the network and sign into your VIDAA Account at  >  **VIDAA Account**. More information about how to sign into the VIDAA Account, please refer to [Benefits of Smart TV > Using a VIDAA Account](#) in this manual.

How to set up Alexa

1. Press  button to select  **Settings** icon, and select **System > Voice Service > amazon alexa**. Select **Set up now**.
2. Give your TV a name.
3. Download the Alexa app on your mobile device. Open the app and sign in with your Amazon account.

Benefits of Smart TV

4. Search and enable VIDAA Voice skill following the instruction. After the skill is enabled, you will be prompted to finish device pairing. Please finish device pairing with this TV, and make sure this TV is discovered by Alexa before using Alexa service.
5. Now Alexa is set up and ready. You can enjoy interacting with Alexa using your voice by just by asking Alexa.

Note:

- The Alexa function may not be applicable in some models/countries/regions.
- The setup steps above may vary. Please refer to the specific product.
- Shipment with voice remote control varies depending on TV models/countries/regions.
- This feature requires Alexa built-in service. Otherwise, use external Alexa-enabled devices (e.g. Alexa App, Echo) to control your smart TV by using just your voice.



Related information

[Connect to a Wired \(Ethernet\) Network](#) on page 4



[Connect to a Wireless Network](#) on page 5

Google Smart Home Service Setup

For specific models and countries/regions, Google Smart Home Service function is available. Set up Google Smart Home Service to control your smart TV with Google Home devices or the App. You can change channels or inputs, adjust volume and more.

Before setting up the Google Smart Home Service, connect your TV to the network and sign into your VIDAA Account at  >  **VIDAA Account**. More information about how to sign into the VIDAA Account, please refer to [Benefits of Smart TV > Using a VIDAA Account](#) in this manual.

STEP 1: Set up Google Smart Home Service on TV

1. Press  button on your remote to select  **Settings** icon and select **System > Voice Service > Google Smart Home Service**. Select **Set up now**.
2. Sign into your VIDAA account. If you have signed in before, this step will be skipped.
3. Give your TV a name.

STEP 2: Set up in Google Home app

Follow the setup instructions on-screen to set up the Google Smart Home Service.

1. Download and install the Google Home app on your mobile device, then open the app.
2. Find and select VIDAA Voice service in the app.
3. Follow the instructions in the app to link your VIDAA account signed in on your TV to your Google Account.

Google Smart Home Service is set up and ready. Control your smart TV by using your voice through the Google Home device or App.

Note:

- Google Smart Home Service may not be applicable in some models/countries/regions.
- The setup steps above may vary. Please refer to the actual product.

Related information

[Connect to a Wired \(Ethernet\) Network](#) on page 4

[Connect to a Wireless Network](#) on page 5

Benefits of Smart TV





VIDAA Voice Setup

VIDAA Voice is a voice assistant to help you control the TV and search content, supporting several languages.

Before using VIDAA Voice, please check the following:



- Network connected
- Voice remote paired
- End User License Agreement and voice feature privacy policy/terms agreed

To access the Voice Service centre and set voice assistant to VIDAA Voice, you can choose one of following options:

- Just press  button on your remote.
- Press  button on your remote and select  **Voice** icon in the navigation bar.
- Press  button to select  **Settings** icon and select **System > Voice Service**.

When VIDAA Voice is selected as your voice assistant, select the language of VIDAA Voice in Voice Service centre. Then, press and hold the  button on your remote to interact with VIDAA Voice.

Note:

- VIDAA Voice may not be applicable in some models/countries/regions.
- Shipment with remote varies depending on TV models/countries/regions.
- For remote without the Microphone button, download and install the app on your mobile device at  >  **Settings > Support > Mobile App Installation**. Press the Microphone icon in the app to interact with your TV.

Related information



[Connect to a Wired \(Ethernet\) Network](#) on page 4

[Connect to a Wireless Network](#) on page 5

[Using the Mobile App](#) on page 19

Voice Service Other Issues

If you want to turn on your TV with Alexa-enabled devices (e.g. Echo, Echo show) or Google Home devices (e.g. Google Home, Google Nest Hub), please:

1. Turn on **Wake on LAN** and **Wake on Wireless Network** at  >  **Settings > Network**.
2. Make sure your TV and Alexa-enabled devices/Google Home devices are connected to the same network environment.

Note:

- Only Alexa (Alexa skill is enabled) and Google Smart Home Service support turning on your TV with Alexa Echo or Google Home.

Related information

[Connect to a Wired \(Ethernet\) Network](#) on page 4



[Connect to a Wireless Network](#) on page 5

Content Sharing

Content Sharing allows you to view media content, like videos, music or photos saved in your Android/iOS/PC device on your TV screen.

Benefits of Smart TV

Share Media Content from your Android/iOS/PC Device

1. Connect your TV and Android/iOS/PC device to the same network.
2. Turn on Content Sharing at  >  **Settings** > **System** > **Application Manager** > **Content Sharing**.
3. Turn on the content sharing function in your Android/iOS/PC device.
4. Find the TV name in the search list of your device and select it. Wait for the connection progress to complete.
5. On your Android/iOS/PC device, choose the media content you want to share on your TV.

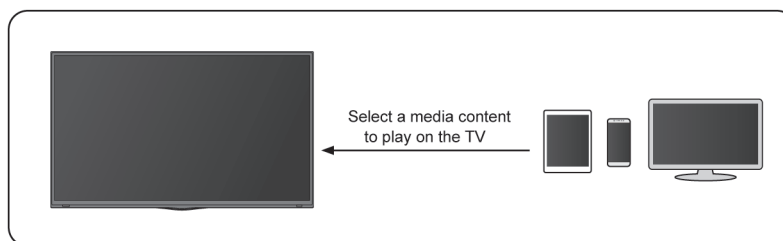





Related information

[Connect to a Wired \(Ethernet\) Network](#) on page 4

[Connect to a Wireless Network](#) on page 5

Play Media Content from your Device on the TV

You can connect media content saved in your Android/iOS/PC device to your local network and play the content on your TV.

1. Connect your TV and Android/iOS/PC device to the same network.
2. Turn on Content Sharing at  >  **Settings** > **System** > **Application Manager** > **Content Sharing**.
3. Make sure your media content in your Android/iOS/PC device are visible through the local network.
4. On your TV, select a device with media content at  >  **Input**, or  > **My Apps** > **Media**. The media content list in your Android/iOS/PC device appears.
5. Select a media content item from the list to play.

Note:

- Some Android/iOS/PC devices may not support content sharing function. If your device does not support content sharing, you can download an app that supports the function to connect to your TV. For more information, please refer to [Benefits of Smart TV > Using the Mobile App](#) in this manual.
- Content may not be played depending on the file format.
- Content may not be played smoothly, or the function may not work properly due to the network condition.

Using Apps

> My Apps

Numerous factory-installed apps are available for you to choose for your entertainment preferences.

Benefits of Smart TV

Install an App from App Store

Even though your TV has numerous factory-installed apps, there may be others that you would like to download.

To install an app:

1.  > **My Apps** > **APP STORE**.
2. Use the navigation buttons on your remote to select the app that you want to install.
3. Select **Install**. The selected app is installed on the TV.

Note:







- To use this function, your TV must be connected to the Internet.
- Adding apps is free, but it might cost you money when using some apps.

Related information

[Connect to a Wired \(Ethernet\) Network](#) on page 4

[Connect to a Wireless Network](#) on page 5

Manage Apps

1. In **My Apps**, select the app you want to sort, then press  button to select **Sort**.
2. Press  /  /  /  button to move it.
3. Press  button to store position.

Note:

- Some Apps may not be moved.

Remove an App

You can only delete apps that you have installed to the TV. Factory-installed apps cannot be deleted.





1. In **My Apps**, select the app you want to remove, then press  button to select **Remove**.
2. Select **OK**. The selected app is deleted.

Using the Art App

 > **My Apps** > **ART**

Numerous artworks created by global artists presented for you to browse or set as a screensaver.

- Browse artworks

When you select an artwork to browse in full screen mode, press  /  button to switch artworks and press  /  /  button to display detailed information of the artwork. You can communicate with the artist using your mobile phone to scan the QR code on the TV screen.

- Add artworks to your favorite list

Press  button on your remote to add the selected artwork to your Favorite list.

- ART settings

Select  icon in ART to set up **Time until the screen saver starts automatically**, **Picture switching time**, **Backlight** and **Screen saver selection**.

Benefits of Smart TV

Note:

- This feature may not be applicable in some models/countries/regions.

Enjoy the Internet

> My Apps > Browser

You can enter websites and browse information on the Internet.

Make sure your TV is connected to the network before accessing the internet via the Browser.

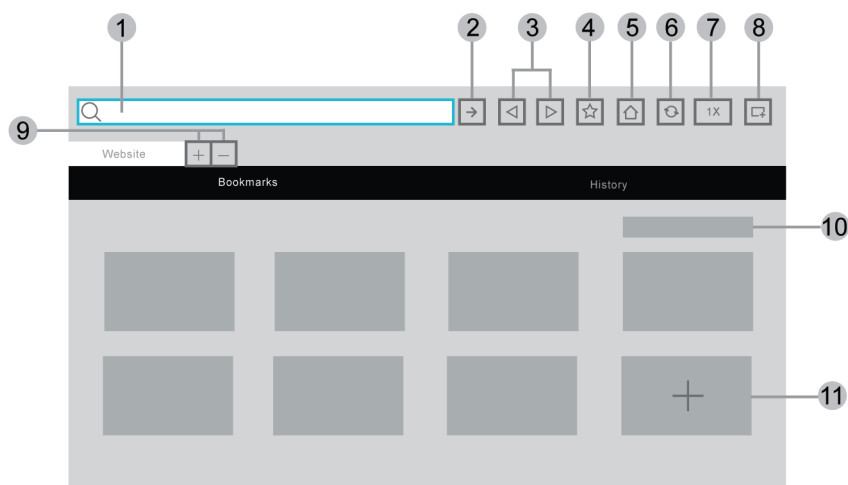

1. Enter website you want to visit
2. Visit/Search
3. Back/Forward: switch among webpages
4. Add the website you are viewing to Bookmarks
5. Back to the Homepage
6. Reload the website
7. Zoom
8. Add to Shortcuts on the Home screen.
9. Add/remove webpages
10. Manage websites in Bookmarks
11. Add websites to Bookmarks

Note:

- The image is only for reference and may differ from the actual product.
- Some contents in the Browser may not be played properly.

Related information

[Connect to a Wired \(Ethernet\) Network](#) on page 4

[Connect to a Wireless Network](#) on page 5

Benefits of Smart TV



Set Usage Mode

 >  **Settings** > **System** > **Advanced Settings** > **Usage Mode**

Set the TV to use in Home or Store mode.

Home Mode



Select Home Mode for normal TV usage.

If you want to switch to Store Mode when the TV is in Home Mode, press  button to select  **Settings**, and select **System** > **Advanced Settings** > **Usage Mode**, and choose **Store Mode**.

Store Mode

Select Store Mode to setup the TV in a retail setting. This mode enables E-Pos and other demo functions and is only intended for use in retail stores.



When Store Mode is selected, press  button on your remote to enter store mode settings.

If you want to switch to Home Mode when the TV is in Store Mode, press  button on your remote to enter store mode settings and choose **Home Mode**. Alternatively, press  button to select  **Settings**, and select **System** > **Advanced Settings** > **Usage Mode**, and choose **Home Mode**.

Note:



- Enabling Store Mode could increase energy consumption.
- How to exit Store Mode varies depending on models/countries/regions.

Using the Mobile App

Press  button to select  **Settings** icon, and select **Support** > **Mobile App Installation**.

Scan the Mobile App Installation QR code on screen to install the app on your mobile device. It is a convenient and easy way to control your TV. This app is available on both Android and iOS.

To connect to your TV after installing the mobile app:

1. Make sure your mobile device and TV are connected to the same network environment.
2. To use this function, switch on **Content Sharing** at  >  **Settings** > **System** > **Application Manager** > **Content Sharing**.
3. Open the mobile app and select the TV device you want to connect.

What you can do with the app:

- Turn the TV on or off
- Volume up or down
- Switch channels
- Input characters with your mobile's keyboard
- Share pictures, music, or videos from your mobile device to the TV

Note:

- This function may not be applicable in some models/countries/regions.

Related information

[Connect to a Wired \(Ethernet\) Network](#) on page 4

Benefits of Smart TV

[Connect to a Wireless Network](#) on page 5

Connecting to External Devices



Remote & Accessories

Connect remote or other accessories, such as keyboard, mouse, to interact with your Smart TV with ease.

Connect Remote Control

Connect a Bluetooth remote control

Pair the Bluetooth remote with the TV.



1. To pair the Bluetooth remote to the TV after you power the TV on, select  >  **Settings > Network > Bluetooth to On.**
2. Keep the remote within 3 metres of the TV. Press any button (except power and mic button) to pair the remote with the TV.

Note:

- In special cases, press and hold  button to pair.
- This function may not be applicable in some models/countries/regions.
- If an error occurred while trying to pair the remote, it could have been caused by interference. Try to remove what is causing the interference and try pairing again.
- If an error occurred with the remote while using sufficiently charged batteries, you can take out the batteries for 1~2 seconds then insert them back again. Now the remote will work normally.
- The remote cannot be paired to the TV while the TV is in standby mode.

Use HDMI-CEC

Use the TV remote to control external devices that are connected to the TV by a HDMI cable. The external devices need to support HDMI & CEC function.

 >  **Settings > System > HDMI-CEC**

Connect an external device through HDMI-CEC function

 >  **Settings > System > HDMI-CEC > HDMI-CEC**

Allow HDMI devices to control each other.

1. Set **HDMI-CEC to On.**
2. Connect a HDMI & CEC compatible device to the TV.
3. Turn on the connected external device. The device will be connected to the TV automatically. After connection is completed, you can access the menu of the connected device on your TV screen using your TV remote and control the device.
4. When CEC control is enabled and HDMI & CEC compatible external devices are turned off, the TV will enter the standby mode. The function needs to be supported by the external device.

Enable device auto power off

 >  **Settings > System > HDMI-CEC > Device Auto Power Off**

Set to **On** to turn off HDMI & CEC compatible external devices when the TV is turned off.

Enable device auto power on

 >  **Settings > System > HDMI-CEC > Device Auto Power On**

Connecting to External Devices

Set to **On** to turn on HDMI & CEC compatible external devices when the TV is turned on.

This feature is applicable when TV input source is pre-set to the corresponding external device.

Enable TV auto power on

 >  **Settings > System > HDMI-CEC > TV Auto Power On**

Set to **On** to turn on the TV when HDMI & CEC compatible external devices are turned on.

Show available devices

 **Settings > System > HDMI-CEC > Available Devices**

View CEC devices that are connected to the HDMI port on the TV.

Note:

- HDMI cables must be used to connect HDMI & CEC compatible devices to your TV.
- The HDMI & CEC feature of the connected device must be turned on.
- If you connect an HDMI device that is not HDMI & CEC compatible, all the HDMI & CEC control features do not work.
- Depending on the connected HDMI device, the CEC control feature may not work.
- The CEC feature supports One Touch Play, Routing Control, System Standby, Device OSD Name Transfer, Remote Control Pass Through, Give Device Power Status, System Audio Control.

Related information

[HDMI & CEC Issues](#) on page 61



Control the TV with a Keyboard, Mouse

Connect a keyboard, mouse to control your TV with ease.

Connect a USB keyboard, mouse

Plug the keyboard, mouse cable into the USB port of your TV.

Connect a Bluetooth keyboard, mouse

Find the Bluetooth device name in  >  **Settings > Network > Bluetooth > Equipment Management** and select it.

Note:

- Keyboard, mouse connected via USB or Bluetooth technology may not be usable with some Apps.
- Bluetooth function may not be supported depending on the models/countries/regions.
- For more information about how to connect a Bluetooth device, refer to the Bluetooth device's user manual.

Related information

[Connect a Bluetooth Device](#) on page 23

Connecting Bluetooth Devices

You can connect to devices using Bluetooth technology.



 >  **Settings > Network > Bluetooth**

Connecting to External Devices

Note:

- Bluetooth function may not be applicable in some models/countries/regions.

Turn on Bluetooth Feature on your TV





Select  >  **Settings** > **Network** > **Bluetooth to On**.

Note:

- This function may not be applicable in some models/countries/regions.

Connect a Bluetooth Device

To pair a Bluetooth device, such as Bluetooth headphones, speakers, keyboards, mouse or even mobile devices:

1. Set  >  **Settings** > **Network** > **Bluetooth to On**.
2. Before pairing your Bluetooth device, make sure it is in the pairing mode and placed within pairing range. To put your Bluetooth device in pairing mode, refer to the user manual of your device.
3. Find the Bluetooth device name in  >  **Settings** > **Network** > **Bluetooth** > **Equipment Management** and select it. The device will be automatically connected to the TV.

Note:

- Only one Bluetooth speaker or Bluetooth headphone can be connected to the TV. If a new Bluetooth speaker or headphone connects to the TV, the existing one will be disconnected automatically.
- Some compatibility issues may occur depending on the Bluetooth device support.
- Bluetooth keyboards may not be functional with some applications.
- The TV and Bluetooth devices may become disconnected if the distance between them is too long.
- This function may not be applicable in some models/countries/regions.

Related information

[Headphone Settings Setup](#) on page 37

Listen to the Audio through Bluetooth Devices

Pair the Bluetooth audio device using the TV's Bluetooth setup process. Refer to the user manual for your audio device, such as Bluetooth speaker or sound bar, for detailed connection and setup.

After the Bluetooth connection is completed, go to  >  **Settings** > **Sound** > **Audio Output Settings** > **Audio Output**, and then select **Bluetooth** option to listen to the audio through Bluetooth devices.

Note:

- Compatibility issues may occur depending on the Bluetooth device.
- The TV and Bluetooth devices may become disconnected if the distance between them is too long.
- This function may not be applicable in some models/countries/regions.

Listen to your Mobile Device Audio through the TV



 >  **Settings** > **Network** > **Bluetooth** > **TV Bluetooth Speaker**

Mobile devices are connected to the TV via Bluetooth and audio is played via the TV speaker.

Connecting to External Devices

When your mobile device is connected to the TV via Bluetooth, you can play your mobile phone's music through the TV built-in speakers.

Go to your mobile Settings to enable Bluetooth and choose the TV to connect.

To use this function, make sure to select **TV Speaker** at  >  **Settings** > **Sound** > **Audio Output Settings** > **Audio Output**.

Note:

- This function may not be applicable in some models/countries/regions.



Related information

[Select Speakers](#) on page 36

Connecting a Set Top Box

Before connecting a Set Top Box to the TV, make sure the TV and Set Top Box are turned off.



Most STB's can be connected via HDMI, HDMI offers the best picture and sound quality. For more information about how to connect a Set Top Box to your TV, please refer to [Connecting to External Devices > Connecting Audio Visual \(AV\) Devices](#) in this manual.

When the connection is completed, turn on your TV and Set Top Box, switch to the input source by pressing the  button, then select the  **Input** icon on Home screen or press the  button to change to the port that you connected your Set Top Box to.

Connecting a Blu-ray or DVD Player

Before connecting a Blu-ray or DVD player to the TV, make sure the TV and Blu-ray / DVD player are turned off.

It is recommended to connect your devices with a HDMI cable (if HDMI port is available) to enjoy better picture and sound quality. More information about how to connect a Blu-ray or DVD player to your TV, please refer to [Connecting to External Devices > Connecting Audio Visual \(AV\) Devices](#) in this manual.

When the connection is completed, turn on your TV and Blu-ray / DVD player, switch to the input source by pressing the  button, then select the  **Input** icon on Home screen or press the  button to change to the port that you connected your Blu-ray / DVD player to.

Sharing your Smart Phone/Computer Screen on the TV

Before using the feature, please set your TV to the wireless network connection.

> Screen Sharing

1. Turn on the casting function of your Android/Windows 10/computer device. The setting icon may vary depending on the device. The feature may be called "Wireless display", "Smartview", "Wireless projection", etc.
2. Find the TV name in the searching list of your device and select it. Wait for the connection progress to complete and the content on your device will be displayed on the TV.

Note:

- Some devices may not support casting.

Connecting to External Devices

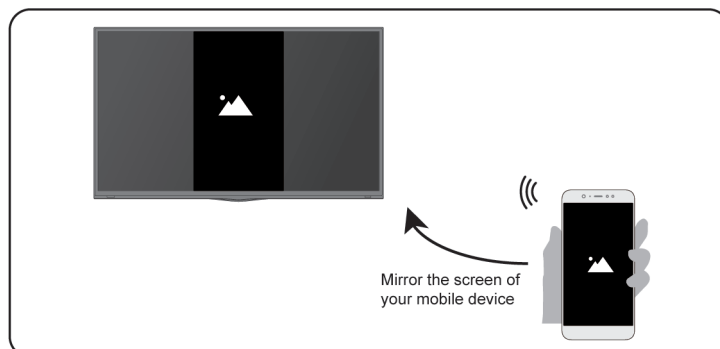

Related information

[Connect to a Wireless Network](#) on page 5

Using AirPlay and HomeKit

Note:



- This function may not be applicable in some models/countries/regions.

Using Airplay

Use AirPlay to wirelessly share audio and video content from your iPhone, iPad, or Mac to your TV. Stream music and videos, share your photos, or mirror exactly what's on your device's screen.

AirPlay is a source in Inputs. Press the  button on your remote control to show the input list, then select AirPlay to enter AirPlay. Then you can select AirPlay and HomeKit Settings. You can also find AirPlay and HomeKit settings in system settings on your TV.

How to use AirPlay:

1. Make sure your Apple device is connected to the same network as your TV.
2. Locate the AirPlay icon on supported media apps, or the Screen Mirroring icon in Control Center on your Apple device. Depending on the content, these steps may vary:
 - To mirror your device's screen, open Control Center and tap Screen Mirroring .
 - To stream audio from supported music or podcast apps, tap AirPlay audio .
 - To stream video from supported apps, tap AirPlay video .
3. Select your TV from the list to begin using AirPlay.

Note:

- An AirPlay-enabled TV.
- The TV and Apple devices are connected to the same network.
- The icon is only for reference. In some apps, you may have to tap another icon first.
- If an AirPlay passcode appears on your TV screen, enter the passcode on your Apple device to continue.

Using HomeKit

Use HomeKit to easily and securely control your TV using your Apple devices.

Connecting to External Devices

1. To set up HomeKit, open AirPlay and HomeKit settings on the TV. Locate the HomeKit section and select 'Set Up'.
2. The HomeKit setup screen will display a pairing QR code on the TV. Use your iPhone or iPad to scan the QR code, then follow the on-screen directions to complete HomeKit setup.

Note:

- Available operations vary depending on the version of the app and software.

Connecting USB Devices

Connect USB devices, such as hard drives and USB sticks for browsing photos or listening to music.

Read before connecting USB devices

USB disk sizes 4GB, 8GB, 16GB, 32GB, 64GB, 128GB and other common market sizes are supported. Up to 8TB hard drives are supported.

Supported formats: NTFS, FAT32.

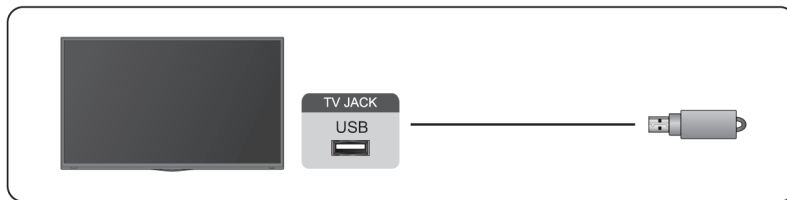

Select the content you want to play or view. For more information, please refer to [Entertainment > Media](#) in this manual.

Using the USB storage device function

The USB storage device function can be used to record and view digital broadcast programmes.

Read the precautions below before recording or viewing programmes by using the USB storage device function.

Note:

- Be sure to select the correct country/region for use.
Use of the recording function may not be applicable depending on the selected country/region. Use with incorrect settings may violate certain laws or other regulations, and may result in criminal punishment. In such cases, our CORPORATION and the Group shall bear no responsibility whatsoever.
- Recorded programs saved in the USB storage device can only be viewed on this TV. They cannot be viewed when connected to another TV (including the same model of TV), a PC, or other devices.
- You cannot watch one channel while recording another.
- If the recording time to the USB storage device is too short, no data may be saved.
- You cannot record video input signals in the USB device.
- Not all types of broadcast may be recordable.
- After programming the TV to record digital broadcasting, do not disconnect the power plug before recording starts.

Connecting to External Devices

- If video or audio recording fail due to malfunction of the TV or poor reception, no compensation shall be paid.
- Certain digital cameras may not be compatible with the TV.

Connecting Headphones

You can connect a pair of headphones (not provided) to the HEADPHONE port on your TV. While the headphone is connected, the sound from the built-in speakers will be disabled.

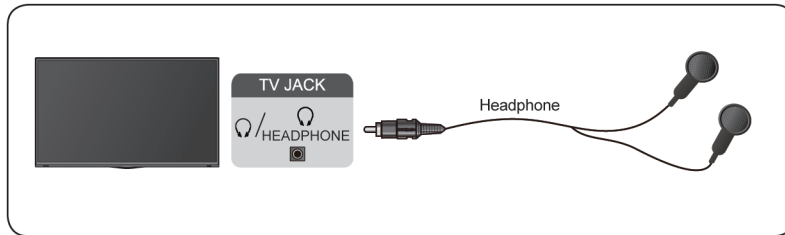

Note:

- Headphone port may not be available in some models.
- Headphones with microphones are not supported.
- If **Headphone with Speakers** is selected at **Settings > Sound > Headphone > Headphone Mode**, the headphone and the TV will have sound output at the same time.

Related information

[Headphone Settings Setup](#) on page 37

Connecting Audio Visual (AV) Devices

Connect with a composite video cable

To connect an AV device with a composite video cable (not provided), see the illustration below.

When the connection is completed, using your remote, select the **Input** icon on the Home screen and select **AV** as the input source.

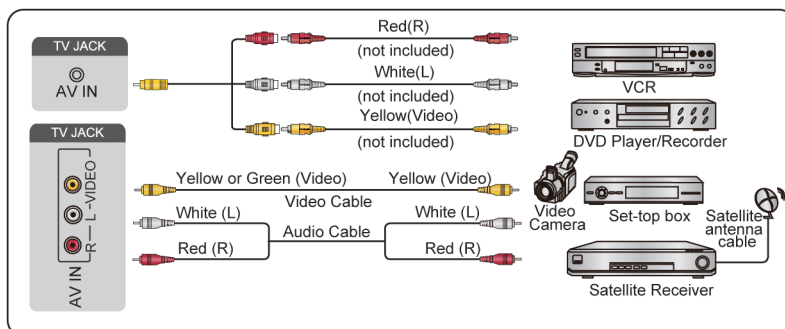

Note:

- AV IN port(s) may vary depending on model type.

Connecting to External Devices

- AV IN port(s) may not be available in some models. Please use other port(s) to connect AV devices.

Connect with a HDMI cable

To connect an AV device with a HDMI cable (not provided), see the illustration below.

When the connection is completed, using your remote, select the  **Input** icon on Home screen, and select the corresponding HDMI input.

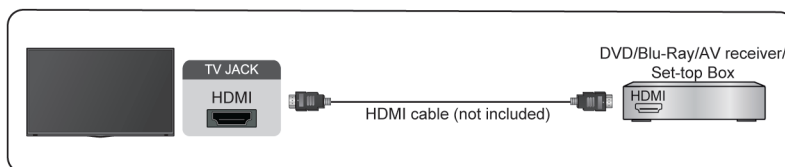

Note:

- Please refer to the User Manual of your device for step-by-step instructions.
- Some devices, such as DVD players, require the HDMI signal to be set to the correct format in the device settings. Please consult your device user manual for instructions.
- If there is no sound from your TV, configure the device audio settings.

Related information

[Use HDMI-CEC](#) on page 21

Connecting Speakers or Other Audio Receivers

To connect speakers or other audio receivers with an audio cable (not provided), see the illustration below.



Ensure the audio connected devices are switched on before switching on the TV.

When the connection is completed, go to  >  **Settings** > **Sound** > **Audio Output Settings** > **Audio Output**, and select the **SPDIF** option.

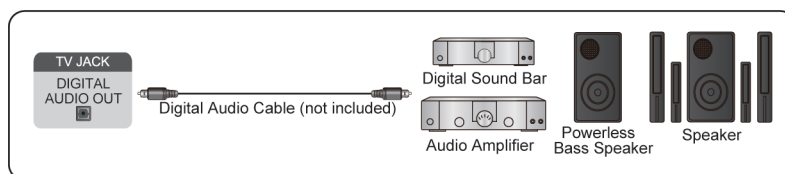
When a digital audio system is connected to the DIGITAL AUDIO OUT port, decrease the TV volume, and use your digital audio system to control the volume.



Note:

- If you prefer to use Audio Return Channel/Enhanced Audio Return Channel, please refer to [Connecting to External Devices > Connecting a Digital Audio System with ARC](#) in this manual.
- You can connect the DIGITAL AUDIO OUT port on the back of the TV to the optical port on the amplifier. Then go to  >  **Settings** > **Sound** > **Audio Output Settings** > **Digital Audio Out** to select **Dolby Auto - Dolby Digital** to receive the Dolby Digital audio.

Connecting to External Devices

☰ Related information

[Select Speakers](#) on page 36

Connecting a Digital Audio System with ARC

If you would like to use the Audio Return Channel (ARC) feature to send sound from the TV by a HDMI cable to a digital sound system, you can connect it to the HDMI (ARC) port of your TV.

By using this feature, you can also control the sound system with your TV remote instead of using the remotes for each device.

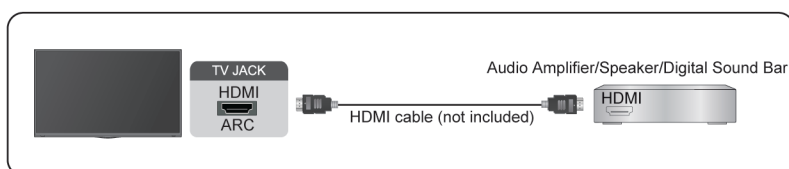

After the connection:

1. Power on the sound system.
2. Press button to select **Settings** icon on the Home screen.
3. Select **Sound > Audio Output Settings > Audio Output**, and select **ARC** option.

Note:

- Audio receiver must support ARC function.
- If the device has an Input Selector feature, then make sure to change it to TV.
- When this port is used for ARC function, it can be used as signal input when a DVD is connected to an amplifier and the amplifier is connected to the TV at the same time. Some amplifiers may not support series connection.
- 5.1 CH (channel) audio is available when the TV is connected to an external device that supports 5.1 channel surround sound. You can press button to select **Settings** icon on the Home screen, and select **Sound > Audio Output Settings > Digital Audio Out** to choose **Dolby Audio - Dolby Digital Plus** to receive the 5.1 channel audio.

☰ Related information

[Select Speakers](#) on page 36

Connecting a PC

You can connect a PC to the TV with a HDMI cable to use your TV as a PC monitor.

After connecting the PC, press the button, then select **Input** icon on Home screen or press

/ button. Select the connected PC as the input source.

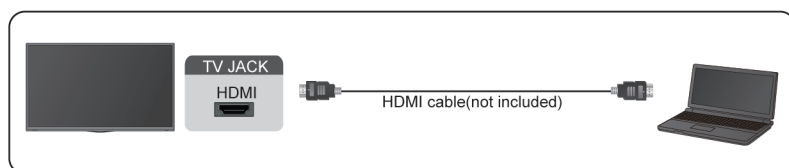

Connecting to External Devices

Note:

- For better image quality, set the PC's resolution, and make sure the resolution is supported by the TV.
- If there is no sound from your TV, change the PC's audio settings.
- If you want to connect your PC and TV wirelessly, please refer to [Benefits of Smart TV > Content Sharing](#) or [Connecting to External Devices > Sharing your Smart Phone/Computer Screen on the TV](#) in this manual.

Settings Overview

Picture

Adjust picture mode, picture size and other advanced picture settings.

Choose a Picture Mode

 >  **Settings > Picture > Picture Mode**

Select a pre-set picture mode to best suit the content you are viewing.

Note:

- Options may differ depending on your model/country/region and the content you are watching. Please refer to the specific product.

When you use a normal signal

- **Vivid**
- **Standard**
- **Energy Saving**
- **Theater**
- **Game**
- **Sports**
- **Calibrated**

When you use a HDR signal

HDR (high dynamic range) can improve the viewing experience with higher contrast and vivid colors. Bright whites look brighter and dark blacks look darker. TV can display a wide range of colors.

When you use a Dolby Vision signal

Note:

- This function may not be applicable in some models/countries/regions.

Inspired by cinema technology, Dolby Vision is the format that allows your TV to deliver a full range of colours, high dynamic range images, brighter whites and dark blacks using scene-by-scene calibration.

Related information

[Picture Issues](#) on page 58

Change the Picture Size

 >  **Settings > Picture > Picture Size**

You can adjust the Aspect Ratio to stretch or zoom in on your picture. You can choose from the following settings: **Auto**, **Normal**, **Zoom**, **Wide**, **Direct**, **Dot-By-Dot**, **Panoramic** or **Cinema**, etc.

Note:

- Using the special functions to change the size of the displayed image (e.g. changing the height/width ratio) for the purpose of public display or commercial gain may infringe on copyright laws.
- If the aspect ratio of the selected format is different from the one of the TV transmission or video programmes, it can cause a difference in vision.
- When connecting your PC to the TV via HDMI terminal, the moving image quality may be deteriorated.

Settings Overview

Related information

[Picture Issues](#) on page 58

Advanced Picture Settings Setup

> Settings > Picture > Picture Mode Settings

Adjust display settings for each Picture Mode. You can personalise the picture quality by adjusting the following settings.

- **Apply Picture Settings**

Apply current picture mode settings to all the input sources or just the current source.

- **Backlight**

Set the overall brightness of the screen.

Note:

- The function name may vary depending on the model type.

The following option may differ depending on models. Please refer to the actual product.

Dynamic Backlight Control

Enhance the contrast ratio between light and dark areas of the picture.

This function may not be applicable in some models/countries/regions.

Backlight

Adjust how bright you want images to appear, lower settings create darker images (only when **Dynamic Backlight Control** is off).

This function may not be applicable in some models/countries/regions.

Light Sensor Shift

This feature is adjustable only when Automatic Light Sensor is turned on. If the picture is too bright, decrease the value. If the picture is too dark, increase the value.

This function may not be applicable in some models/countries/regions.

Local Dimming

TV will automatically adjust the backlight in specific areas of the screen according to the contrast changes in the image.

This function may not be applicable in some models/countries/regions.

- **Brightness**

Adjust the Brightness level to generate lighter or darker images.

- **Contrast**

Adjust the Contrast level to increase or decrease how bright images appear.

- **Color**

Adjust the color intensity of the picture for a more vibrant image.

- **Tint**

Adjust the colors from a green to magenta tint to view the natural skin tones of people on the screen.

- **Sharpness**

Adjust how sharp or soft the edges of images appear.

Settings Overview

- **Adaptive Contrast**

Automatically adjust dark areas and light areas of the image to see more detail.

- **Ultra Smooth Motion (or AquoMotion Enhancement for some models)**

Reduce the afterimage effect when viewing fast-moving objects.

This function may not be applicable in some models/countries/regions.

- **Clear Motion**

Reduce judder and blur from video content.

This function may not be applicable in some models/countries/regions.

- **Noise Reduction**

Improve the picture quality by reducing noise.

- **MPEG Noise Reduction**

Reduce MPEG block noise to provide clearer edge transitions.

- **Color Temperature**

Adjust how warm (red) or cool (blue) the white areas of an image appears.

- **Expert Settings**

Adjust advanced picture settings based on your viewing preference.

Please refer to [Expert Settings Setup](#) in this manual.

- **Overscan**

Change the video size setting to crop the edges of the displayed image.

This function may not be applicable in some models/countries/regions.

- **Reset Picture Settings**

Restore all the picture settings in the current picture mode to the factory default values.

 **Related information**

[Picture Issues](#) on page 58

Expert Settings Setup

 >  **Settings > Picture > Picture Mode Settings > Expert Settings**

Adjust the color space and Gamma to best suit the content you are viewing.

- **Color Gamut**

Change the range of colors the TV displays.

This function may not be applicable in some picture mode.

- **Color Tuner**

Adjust the Hue, Saturation and Brightness of color settings.

- **White Balance**

Adjust the intensity of red, green and blue to view the true color of all images in the picture.

- **Black Level**

Adjust the HDMI Black Level to enhance current content.

Settings Overview

- **Gamma Adjustment**

Adjust the Gamma to alter how the TV will respond to grayscale content. In low ambient light choose a higher number, in brighter ambient light select a lower number. The default setting of 2.2 is recommended for most ambient light conditions.

This function may not be applicable in some models/countries/regions.

- **Gamma Calibration**

Adjust selected Gamma curve.

This function may not be applicable in some models/countries/regions.

- **Viewing Angle**

Provide a better viewing experience when watching TV from anywhere in the room.

This function is only available in models supporting the Viewing Angle Control feature.

- **RGB Only Mode**

RGB filter for adjustment and control of color space and color saturation.

 **Related information**

[Picture Issues](#) on page 58

Sound

Adjust sound mode and other advanced sound settings.

Choose a Sound Mode

 >  **Settings > Sound > Sound Mode**

Select a pre-set sound mode to suit the content you are listening to.

- **Standard**

In Standard mode, the TV delivers a flat frequency response, which preserves the natural characteristics of the original sound.

- **Theater**

Theater mode increases the surround sound effect and provides a more prominent bass response.

- **Music**

In Music mode, low and high frequencies are emphasised to enhance musical instrument reproduction.

- **Speech**

In Speech mode, low and high frequencies are attenuated to improve the reproduction and clarity of the human voice.

- **Sports**

Optimized sound for watching Sports events.

- **Late Night**

In Late Night mode, the TV will improve the reproduction and clarity of the human voice with a low volume level.

 **Related information**

[Sound Issues](#) on page 59

Settings Overview

Audio Enhancement

 >  **Settings** > **Sound** > **Audio Enhancement**

Set **Audio Enhancement** to **On** to enhance the richness of sound allowing a more immersive listening experience.

Note:

- This function may not be applicable in some models/countries/regions.

Related information

[Sound Issues](#) on page 59

Sound Mode Settings Setup

 >  **Settings** > **Sound** > **Sound Mode Settings**

Adjust the audio settings of the TV. You can personalise the sound quality by adjusting the following settings.

- **Apply Audio Settings**

Adjust current sound mode to apply to all sources or just the current source.

- **Bass Boost**

Bass Boost uses DTS TruBass™ to enhance the perception of bass frequencies to provide deep, rich bass response from the TV's internal speakers.

This function may not be applicable in some models/countries/regions.

- **Surround Sound**

Surround sound uses DTS TruSurround™ to deliver an immersive surround sound experience from the TV's internal speakers.

This function may not be applicable in some models/countries/regions.

- **Dialog Clarity**

Dialog Clarity uses DTS Dialog Clarity™ to boost the frequency range of the human voice so dialog is clearly understood and heard above audio or surround effects.

This function may not be applicable in some models/countries/regions.

- **TruVolume**

Automatic control over large volume changes while watching TV programmes or films, providing a more comfortable and consistent volume.

This function may not be applicable in some models/countries/regions.

- **Total Sonic**

Optimise the overall sound quality by increasing bass and widening the sound field to provide a clear, natural dialogue.

This function may not be applicable in some models/countries/regions.

- **Total Surround**

Provide surround sound experience with psycho-acoustic processing to place sounds at the side, behind and above the viewer. For best results use with Total Sonics.

This function may not be applicable in some models/countries/regions.

Settings Overview



- **Total Volume**

Maintain a consistent loudness level for a wide dynamic range of programmes, loud commercials and channel or input changes.

This function may not be applicable in some models/countries/regions.

- **Equalizer**

Boost the volume at different frequencies.

This function is only applicable when **TV Speakers** is selected at  >  **Settings > Sound > Audio Output Settings > Audio Output**.

- **Subwoofer**

Enable / Disable internal subwoofer.

This function may not be applicable in some models/countries/regions.

- **Mounting Position**

Automatically optimise the sound based on the position of the TV.

This function may not be applicable in some models/countries/regions.

- **Auto Volume Control**

Activate to prevent the volume from changing when switching TV channels.

This function may not be applicable in some models/countries/regions.

- **Reset Audio Settings**

Restore all of the audio settings in the current audio mode to the factory default values.

Note:

- Some models may not support decoding of DTS CD bitstreams. Playback of this format may produce undesirable noise.

 **Related information**

[Sound Issues](#) on page 59

Select Speakers

 >  **Settings > Sound > Audio Output Settings**

Adjust the settings of speakers.

Audio Output

Select the speakers which you want to use.



Digital Audio Out

Select the digital audio output format that best suits the audio device type.

- **Auto**: the audio device automatically outputs in a supported format.
- **Pass Through**: the audio device outputs without any processing.
- **PCM**: the audio device outputs PCM (pulse code modulation) format.
- **Dolby Audio - Dolby Digital**: the audio device outputs Dolby Digital audio when connected to the TV via the optical port.
- **Dolby Audio - Dolby Digital Plus**: the audio device outputs Dolby Digital Plus audio when connected to the TV via the HDMI (ARC) port.

Settings Overview

Note:

- This function is only applicable when  >  **Settings > Sound > Audio Output Settings > Audio Output** is set to **ARC** or **SPDIF**.
- When external audio devices are connected to the TV via optical, **PCM** and **Dolby Audio - Dolby Digital** are recommended.

Digital Audio Delay

Adjust the digital audio output delay time to sync audio from an external speaker with the images on the TV.

This function is only applicable when  >  **Settings > Sound > Audio Output Settings > Audio Output** is set to **ARC** or **SPDIF**.

Lip Sync

Synchronise the video and audio.

This function may not be applicable in some Audio Output modes.

Balance

Adjust the left and right speaker level to optimise audio for a specific location.

This function may not be applicable in some Audio Output modes.



This function is not applicable when **Dolby Atmos** is turned on.

Related information

[Connecting Speakers or Other Audio Receivers](#) on page 28

[Connecting a Digital Audio System with ARC](#) on page 29

Headphone Settings Setup

 >  **Settings > Sound > Headphone**

Set the sound output mode through headphones.

After connecting your wired or Bluetooth headphone, or other external audio amplifiers, you can set up your TV to your preference.

Note:

- This function may not be applicable in some models/countries/regions.

Network

You can get access to the Internet through your TV.

Check the Internet Connection Status

 >  **Settings > Network > Internet Connection**

Test the current network connection status and view the current network information.

Connection Test

 >  **Settings > Network > Internet Connection > Connection Test**

Settings Overview

Start a network connection test.

Network Information

 >  **Settings** > **Network** > **Internet Connection** > **Network Information**

View information about your network connection.

Related information



[My TV cannot connect to the network.](#) on page 53

[Connect to a Wired \(Ethernet\) Network](#) on page 4

[Connect to a Wireless Network](#) on page 5

Turn on the TV through the Internet

Wake on wireless network

 >  **Settings** > **Network** > **Wake on Wireless Network**

With a wireless network connection and enabling **Wake on Wireless Network**, you can switch on the TV from standby and push content to be viewed on the TV with a mobile device App supporting the screencast function.

Note:

- To use this function, make sure your TV and mobile device are connected to the same network environment.
- Enabling this function may result in higher energy consumption.

Wake on LAN

 >  **Settings** > **Network** > **Wake on LAN**

With a wired Ethernet connection and enabling **Wake on LAN**, you can switch on the TV from standby and push content to be viewed on the TV with a mobile device App supporting the screencast function.

Note:

- To use this function, make sure your TV and mobile device are connected to the same network environment.
- Enabling this function may result in higher energy consumption.

Wake on Cast

You can enable or disable Wake on Cast function which is able to remotely wake up the TV through external devices.

Note:

- This function may not be applicable in some models/countries/regions.

Related information

[Connect to a Wired \(Ethernet\) Network](#) on page 4

[Connect to a Wireless Network](#) on page 5

General

You can set up system settings.

Settings Overview

Note:

- The menus displayed vary depending on models/countries/regions.

Set Time

 >  **Settings > System > Time Settings**

Set the current time based on your location.

- **Time Format**

Set the time display to be 12 or 24-hour format.

- **Date Format**

Set the date display format.

- **Date/Time**

Set the Date and Time. You can set the date and time to automatically sync with Internet/broadcast or manually setup by yourself.

This function may not be applicable in some models/countries/regions.

- **Time Zone**

Select your time zone.



This function may not be applicable in some models/countries/regions.

- **Daylight Saving**

Select whether to apply Daylight Saving Time to the TV.

This function may not be applicable in some models/countries/regions.

Use Timer

 >  **Settings > System > Timers**

Adjust the timer settings to suit your preference.

- **Sleep Timer**

Set the sleep timer to automatically turn the TV off at the specified time.

- **Power On Timer**

Set the time you want the TV to turn on automatically. You can set the same time each day or set a different time on different days.

- **Power Off Timer**

Set the time you want the TV to turn off automatically. You can set the same time each day or set a different time on different days.

- **Menu Timeout**

Set the amount of time you would like the menu to remain on the screen.

Use System PIN

 >  **Settings > System > Parental Control > Change PIN**

Change the PIN that you use to access Parental Control.

Settings Overview

Set Language and Location

 >  **Settings > System > Language and Location**

Select the language used for this TV and your location.

- **Location**
Choose the location from where you will watch your TV.
- **Language**
Set the default language for the TV menu.
- **Preferred Audio Language**
Set the default audio output language for the type of digital broadcast content that you are viewing.
- **Keyboard Layout**
Change External keyboard layout language.

Edit TV Name

 >  **Settings > System > Advanced Settings > TV Name**

You can select Smart TV / Living Room TV / Bedroom TV / Kitchen TV / User Input, when you select User Input, you can edit the name for your TV to be used on the network.

Note:

- Up to 18 characters can be entered.

Power LED Mode Setup

 >  **Settings > System > Advanced Settings > Power LED**

Set the power indicator display to stay On or Off when in Standby mode.

Note:

- The function may not be applicable in some models/countries/regions.

Screensaver

 >  **Settings > System > Advanced Settings > Screensaver**

Activate a screensaver when your TV displays a still image for a period of time. Set the time according to your preference.

Note:

- This function may not be applicable in some models/countries/regions.

 **Related information**

[Using the Art App](#) on page 17



Setup Wizard

 >  **Settings > System > Advanced Settings > Setup Assistant**

Use the Setup Wizard for instructions to help you set up your TV.

Settings Overview

Personalised Ads

Press  button on your remote control and select  **Settings > System > Advanced Settings > Personalised Ads**.

Turning off personalised ads will limit the ability to deliver relevant ads to you but will not reduce the number of ads you receive.

Note:

- This function may not be applicable in some models/countries/regions.

Switch off Curtain

 >  **Settings > System > Advanced Settings > Switch off Curtain**

Enable / Disable **Switch off Curtain** or set how quickly the Screen Curtain will close when entering standby.

Support

You can set up support settings.

Note:

- The menus displayed vary depending on models/countries/regions.

Check Signal Info

 >  **Settings > Support > System Info > Signal Info**



Show the signal information of current input.

Check Network Connection Status

 >  **Settings > Support > System Info > Network Connection**

View the TV's network connection information.

Check Input Connection Status

 >  **Settings > Support > System Info > Input Connection**

View the TV's input connection information.

Check Software Version

To check the current software version of your TV:

Access  >  **Settings > Support > System Info > About**.

System Upgrade

 >  **Settings > Support > System Upgrade**

Set your TV to receive the latest firmware.

Settings Overview

- **Auto Firmware Upgrade**

Set your TV to automatically receive the latest firmware.

- **Check Firmware Upgrade**

Check to ensure that your TV has received the latest firmware.

Please ensure your TV is connected to the Internet.

- **System App Auto Upgrade**

Set your system applications to automatically upgrade to the latest version. App auto upgrade will be completed in the background. Confirmation on new Privacy Notices may be required to complete any upgrades.

- **Upgrade from USB**

Upgrade TV software from USB device.

Note:

- Please ensure the USB flash drive is inserted to the USB 2.0 port of the TV.
- The update files must be located in the root directory of the update USB device.
- The format of the USB must be FAT32 and the partition table type must be MBR.

 **Related information**

[Connecting USB Devices](#) on page 26

Enjoy Safe Use of the TV

Disclaimer and Privacy

 >  **Settings** > **Support** > **Terms and Conditions, Privacy Policy**

Read the EULA and Data Protection Policy. Allow/Deny your consent to the listed policies relating to the collection of User/Network data. To remove any legacy User /Network data select **Remove User Data** from the Menu.

Using Parental Controls

 >  **Settings** > **System** > **Parental Control**

Turn on Parental Control to prevent children from being able to view certain content.

If you have not set the PIN code before, create and confirm PIN window will be displayed. Using the D-pad on the remote, create the PIN code.

If you have set the PIN code before, enter PIN window will be displayed.

- **Parental Control**

Turning Parental Control On

1. Turn on Locks to enable the Parental Control function.
2. Create PIN window displays. Using the D-pad on your remote control, create the password.
3. You will see other Parental Control settings change from a greyed out state to highlighted. When this occurs, begin adding other settings to the Scheduled Blocking, Channel Blocking, Program Blocking, Input Blocking, Change PIN and Reset features.

Settings Overview

- **Scheduled Blocking**
Block certain channels, programs and inputs during certain periods of time.
- **Channel Blocking**
Block selected channels.
- **Program Blocking**
Block programs by ratings.
- **Input Blocking**
Block selected inputs.
- **App Blocking**
Block access to certain apps.
- **Change PIN**
Change the PIN that you use to access Parental Control.
- **Reset Parental Control Defaults**
Restore Parental Control back to the factory default setting.

Reset to Factory Default

 >  **Settings** > **Support** > **Factory Reset**

Restore your TV to the factory default. Reset will clear your personal settings, information and data.





Game

You can connect to your game console and set up settings to optimise the TV screen for better gaming performance.

Connect a Game Console

You can connect your game console with a HDMI cable to the TV.

To start a game from a game console:

1. Switch on your game console.
2. Press the  button, select  **Input** icon on Home screen or press  /  /  button. Select the connected game console as the input source.
3. Start the game.

You can enable the game mode to optimise your TV's settings when playing games with a game console.

Related information

[Game Mode](#) on page 44

Game Mode

 >  **Settings** > **Picture** > **Picture Mode** > **Game**

Enable **Game** to optimise the TV's settings to enjoy a better gaming experience with a PC or a game console connected to the TV.

Game Mode will allow:

- Reducing input lag to make sure every press or click matches what is happening on the screen;
- Improving responsiveness to produce very little motion blur;
- Processing YUV 4:4:4 format signals precisely to present accurate image colors.



Note:

- This function may not be applicable in some input sources or applications.

Related information

[Connect a Game Console](#) on page 44

Enabling Instant Game Response

 >  **Settings** > **Picture** > **Instant Game Response**

You can enjoy a smooth viewing experience with external device connected to the TV when **Instant Game Response** is turned on.

Note:

- When Game mode is selected, Instant Game Response will not be switched off automatically.

Sports

Sports mode setup in picture or sound settings

 >  **Settings** > **Picture** > **Picture Mode** > **Sports**

Entertainment

Optimised picture for watching sports.

🏠 > ⚙️ **Settings** > **Sound** > **Sound Mode** > **Sports**

Optimised sound for watching sports events.

Media

🏠 > **My Apps** > **Media**

Media is a central location for you to view or listen to different types of content, such as photos, music and movies. You can view media content through the following methods:

- A USB thumb drive or hard drive.
- Compatible mobile phone, tablet or other personal devices: you can stream movies, music and photos that are stored on compatible personal devices and play or view the content on your TV.

By default, there is **Content Sharing** displayed on the Media screen. If your mobile device is connected to the TV, its name also appears on the Media screen.

For more information about **Content Sharing**, please refer to [Benefits of Smart TV > Content Sharing](#) in this manual.

Enjoy Photos/Audio/Video Stored on a USB Device

🏠 > **My Apps** > **Media** > **connected devices**

Select the content you want to play on the screen, like pictures, videos and music.

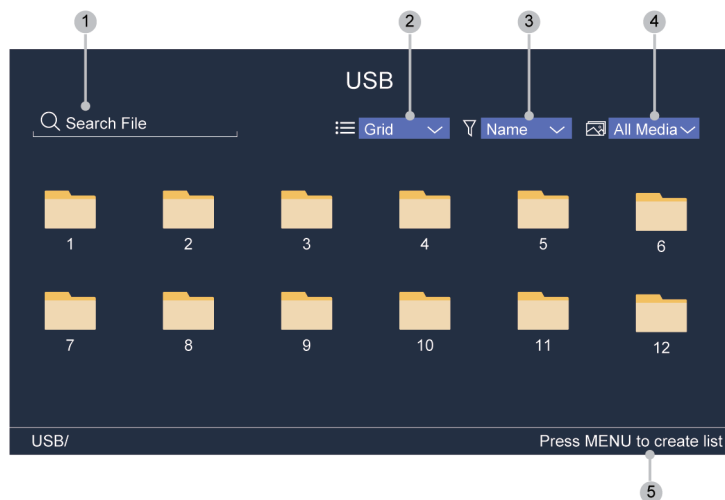

1. Search the content you want to play.
2. Arrange the content list by **Grid**, **List**.
3. Sort the content list by **Name**, **Date modified**, **Size**.
4. Filter the content list by **All Media**, **Photo**, **Video**, **Music**, **Recorded**.
5. Create a photo, music, or video playlist.

Note:

Entertainment

- Some options in the above table may not be available in some models/countries/regions.

Play Background Music while Viewing Pictures

1. Choose a picture to display.
2. Press **▲** / **▼** button to display control bar.
3. Select **Background Music** and choose your music to create a Music Playlist.

Now you can play background music while viewing pictures.

Note:

- For more information about connection to PC/mobile device, refer to the detailed introduction of each part.
- You must obtain any required permission from copyright owners to download or use copyrighted content. We cannot and don't grant such permission.

Audio Format

Due to differences in programming tools and other factors, some of the file formats that are listed may not be supported.

The listed formats may not be supported depending on the model.

Container	Audio Codec	File Extension Name
WAV	Mpeg1/2 Layer1	.wav
MP3	Mpeg1/2 Layer2	.mp3
	Mpeg1/2 Layer3	
AAC	AAC, HEAAC	.m4a .aac
WMA	WMA	.wma
	WMA Pro	
PCM	LPCM	N/A
	ADPCM	
AC-3	AC-3	.ac3 .m4a
FLAC	FLAC	.flac
OPUS	OPUS	.opus

Photo Format

Due to differences in programming tools and other factors, some of the file formats that are listed may not be supported.

The listed formats may not be supported depending on the model.

Container	File Extension Name	Mode of Operation	Resolution
JPEG	.jpg .jpeg	base-line	15360 x 8640
		progressive	1024 x 768
PNG	.png	no-interlace	9600 x 6400
		interlace	1200 x 800

Entertainment

Container	File Extension Name	Mode of Operation	Resolution
BMP	.bmp	-	9600 x 6400
GIF	.gif	-	6400 x 4800

Video Format

Due to differences in programming tools and other factors, some of the file formats that are listed may not be supported.

The listed formats may not be supported depending on the model.

Container	Video Codec	File Extension Name	Resolution and Frame Rate
MPEG	Mpeg1/2	.mpg .mpeg .vob	1920 x 1080p @ 120fps
	Mpeg4		
MP4	Mpeg4	.mp4 .mov	1920 x 1080p @ 120fps
	H.264(AVC)		4096 x 2160p @ 60fps
	H.265(HEVC)		
MKV	Mpeg1/2	.mkv	1920 x 1080p @ 120fps
	Mpeg4		
	H.264(AVC)		4096 x 2160p @ 60fps
	H.265(HEVC)		
AVI	Mpeg1/2	.avi	1920 x 1080p @ 120fps
	Mpeg4		
	H.264(AVC)		4096 x 2160p @ 60fps
WMV	WMV3	.asf .wmv	1920 x 1080p @ 60fps
	H.264(AVC)		4096 x 2160p @ 60fps
FLV	H.264(AVC)	.flv	4096 x 2160p @ 60fps
TS	H.265(HEVC)	.ts	4096 x 2160p @ 60fps



SoundBar Settings

When the soundbar device is connected to the TV, You can change the SoundBar Settings at Settings menu for best device sound quality.

When the ARC device is connected to the TV, the sound output is automatically switched to ARC, if the user switches to other sound output channels, the soundbar menu cannot be adjusted, and the sound menu of TV can be adjusted.

Press  button on your remote, and select  **Settings > Sound > SoundBar Settings**.

Note:

- When you connect a soundbar with an HDMI cable, you should Set **HDMI-CEC** to On by pressing  button on your remote, and select  **Settings > System > HDMI-CEC > HDMI-CEC**.
- Some soundbar device can't support this function.

Entertainment

- **EQ Modes**

You can select **Music, Movie, News, Sport, Night**.

- **Surround Modes**

You can set to **On** to turn on the Surround Modes.

- **Bass Level/Treble Level/Dimmer Level**

You can adjust **Bass Level/Treble Level/Dimmer Level**

- **Reset**

Reset current SoundBar Settings to factory mode.

Accessibility Features

Accessibility Settings

Accessibility function provides menu options and audio descriptions to aid the visually or hearing impaired.

Press  button on your remote control and select **Settings > Accessibility**.

Closed Captioning

You can switch between **CC off / CC on / CC on when mute** in Channel mode.

Press  button on your remote control and select **Settings > Accessibility > Closed Captioning**.

Closed Caption Settings

Press  button on your remote control and select **Settings > Accessibility > Closed Captioning Settings**.

You can set display options.

- **Analog Caption**

Select an Analog Closed Caption setting from Off, CC1-CC4, TEXT1-TEXT4.

- **Digital Caption**

Select a Digital Caption: Off, CS1-CS6.

- **Digital Caption Settings**

You can set display options.

High Contrast Menu

Improves contrast for the visually impaired.

Press  button on your remote control and select **Settings > Accessibility > High Contrast Menu**.

Narration and Narration Volume

If Video Description stream is available, you can turn on this function, and you can change Narration Volume.

Press  button on your remote control and select **Settings > Accessibility > Narration/Narration Volume**.

Voice Guide

Enable or disable Voice Guide.

Press  button on your remote control and select **Settings > Accessibility > Voice Guide**.

Voice Guide Settings

Press  button on your remote control and select **Settings > Accessibility > Voice Guide Settings**.

Adjust settings for the Menu Audio function.

- **Volume**

Set the Menu Audio volume.

- **Language**

Set the Menu Audio language.

Accessibility Features

- **Rate**

Set the Menu Audio speed.

- **Pitch**

Set the Menu Audio pitch.

- **Focus Voice Guide**

Turn down the background volume when menu audio is playing.

Note:

- Some options in the above table may not be available in some models/countries/regions.
- The menu is only for reference and may differ from the actual product.

Troubleshooting

FAQ

In this section you will find the answers to the most frequently asked questions.

Note:

- The images are only for reference and may differ from the actual product.

There is no picture, or the picture is black and white.

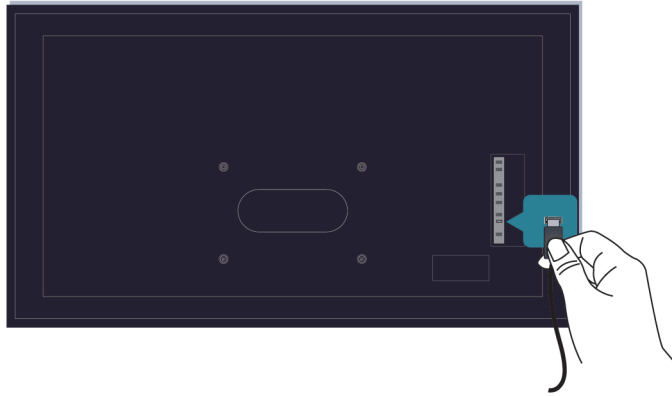

Check input cable connections.

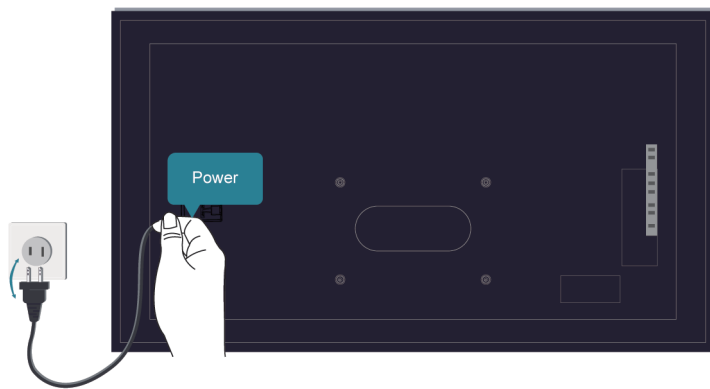

Unplug the TV power cord from AC outlet and re-plug after 60 seconds.

Troubleshooting

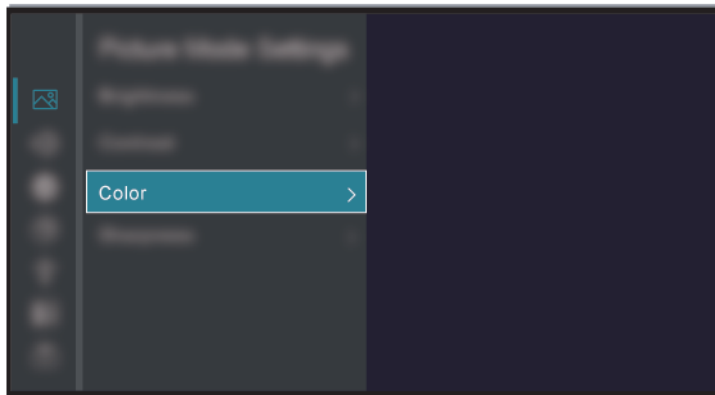

Check if the Color Saturation is set to 50 or higher at  >  **Settings > Picture > Picture Mode Settings > Color**.

No sound or the sound is too low.

There is no sound or the sound is too low at maximum volume.

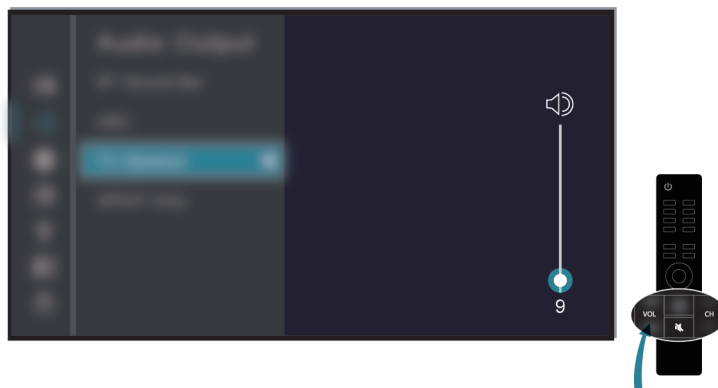

Check if Mute mode is set to on.

Check the volume settings.

Check the volume control of the device (cable or satellite box, DVD, Blu-ray, etc.) connected to your TV.

Troubleshooting

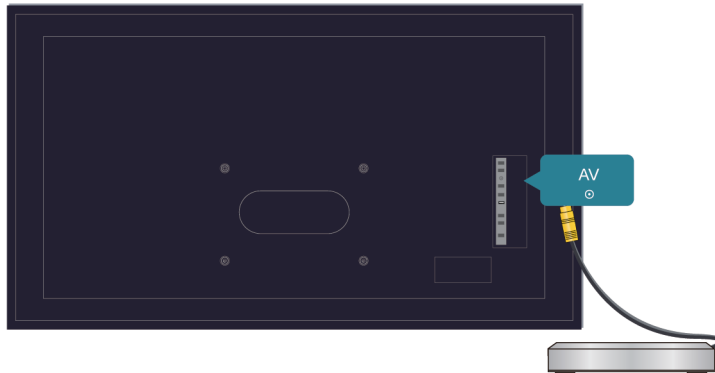

Make sure that the audio cable is connected to the correct audio output connector on the external device.

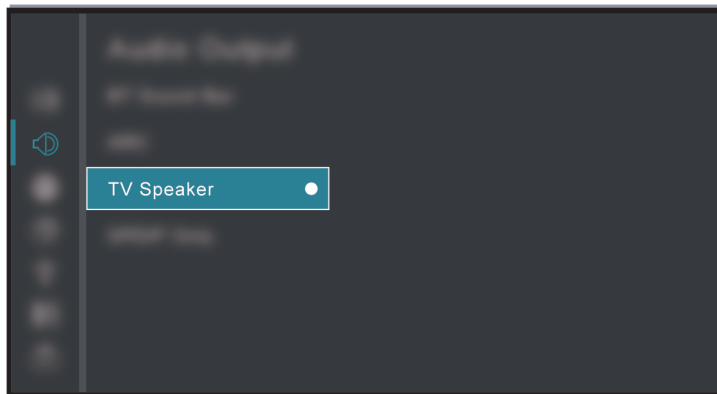

Check whether **TV Speaker** is selected at  >  **Settings** > **Sound** > **Audio Output Settings** > **Audio Output**.

My TV cannot connect to the network.

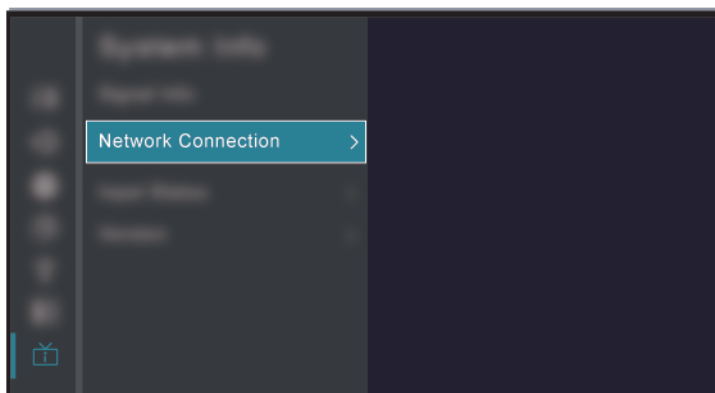

Troubleshooting

Check network status at  >  **Settings** > **Support** > **System Info** > **Network Connection**.

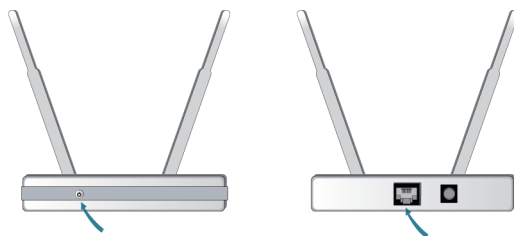

Make sure your modem/wireless router is on and connected to the Internet.

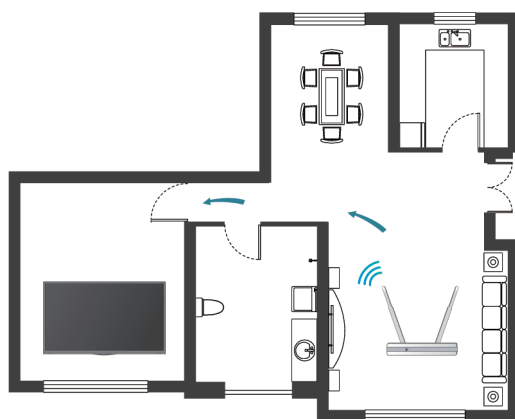

Position your wireless router, modem router, or access point in a central location. Avoid putting it in a corner.

External source connected but no picture or sound.

I have connected an external source to my TV but I get no picture and/or sound.

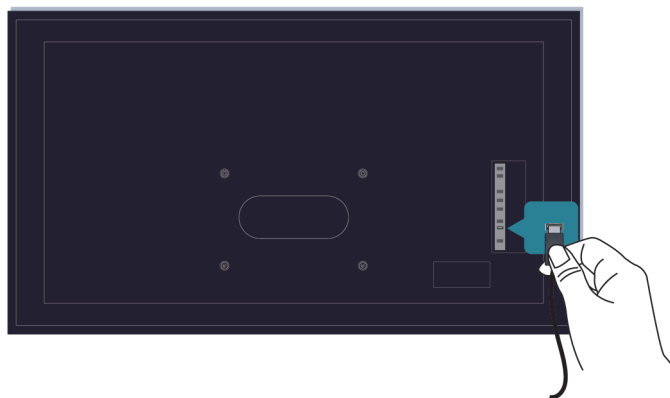

Check whether the connection between the external device and your TV is correct and secure.

Troubleshooting

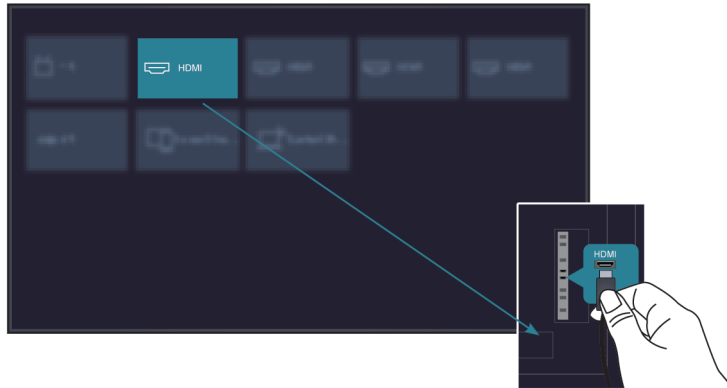

Make sure you have made the correct selection of input source.

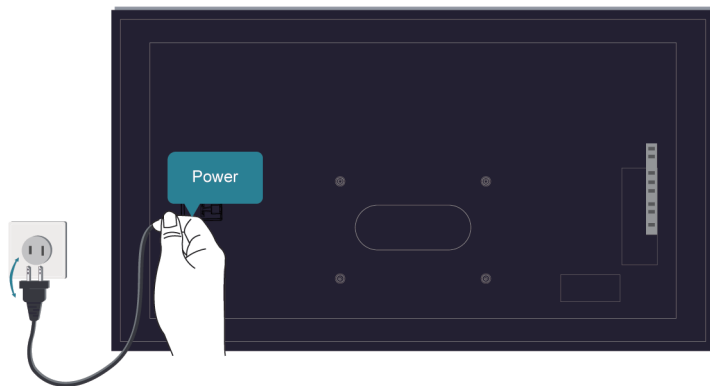

If the signal is intermittent, unplug the TV power cord from AC outlet and re-plug after 60 seconds.

The remote control does not work.

Confirm that TV still has power and is operational. Press the power button on the TV to determine if the problem is with the remote control or not.



Troubleshooting

If the TV is not responding to the remote control, then please check if the small light on the remote control flashes when any button is pressed (some remote controls do not support this function).

If the small light does not flash when the remote control button is pressed, the battery power may be low, please replace the batteries with new ones.

Check that the orientation of each battery matches the positive (+) and negative (-) symbols in the battery compartment.



Keep the remote control sensor area clear from obstacles.

For Bluetooth remote controls



If the TV does not respond with the Bluetooth remote control, try pairing the remote control to the TV by pressing and holding the  button for at least three seconds.

Troubleshooting

Schedule Recording cannot be used.

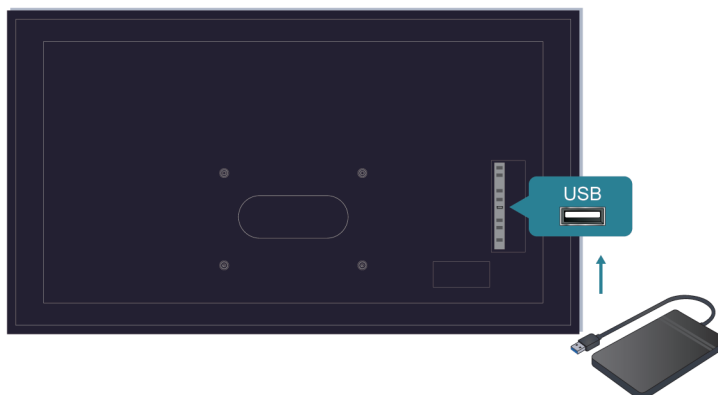

Check if there is a storage device connected to the TV.

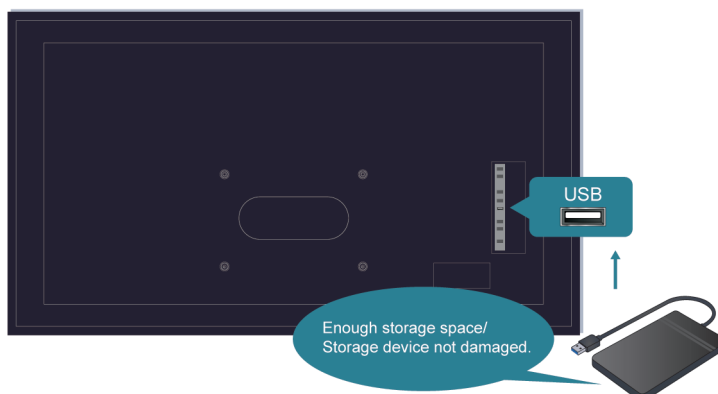

Check the free space of the storage device. The function will not work if there is not enough storage space on the device.

Check whether your storage device is damaged. If so, it is suggested to format your storage device.

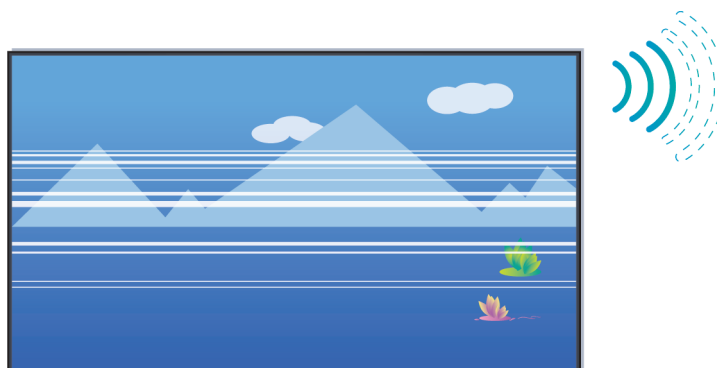



Troubleshooting

Recording will automatically stop if the signal becomes too weak.

Note:

- Recording function may not work if the read/write speed of the USB device is too slow.
- Recording function may not work because the storage format of your device is unsupported.
- The Recording functions may not be applicable in some models/countries/regions.

TV Status Diagnosis

 >  **Settings > Support > Self Diagnosis**

When the TV malfunctions, you can perform some self-diagnosis to find the problem.

- **Picture Test**

When performing the Picture Test, a test picture will be shown on screen. Select OK to start the test. Picture Test displays a high-definition picture that you can examine for flaws or faults. Please check the picture carefully in the next 10s.

- **Sound Test**

When performing the Sound Test, a test sound will be played with the TV Speaker. Select OK to start the test. Please listen to the sound carefully to check whether you can hear the sound problem.

- **Network Test**

When performing a Network Test, the test will confirm whether your TV is connected to network via the TV screen. If the network test is successful but you still have problems using online services, please contact your Internet provider.

- **Bandwidth Monitoring**



Test the speed with a third-party website.

- **Input Connection Test**

When performing an Input Connection Test, you can select from the input sources and check related information with external connections.

Picture Issues





When the TV has a picture problem, these steps may help resolve the problem.

 >  **Settings > Support > Self Diagnosis > Picture Test**

Before you review the list of problems and solutions below, use **Picture Test** to determine if the problem is caused by the TV. **Picture Test** displays a high definition picture that you can examine for flaws or faults.

- If the test picture does not appear or there is noise or distortion, the TV may have a problem. Contact the service company in your country/region.
- If the test picture is displayed properly, there may be a problem with an external device. Please check the connections.
- If the problem persists, check the signal strength or refer to the external device's user manual.

Troubleshooting



Problem	Possible Solutions
The picture is distorted.	<ul style="list-style-type: none"> The compression of video content may cause picture distortions, especially in fast moving pictures from sports programmes and action movies. If the signal reception is weak or poor, screen distortion may be visible but it is not a malfunction. Mobile phones used close to the TV (within 1m) may cause noise on analogue and digital channels.
The picture is blurry or flickering, or cuts out momentarily.	<ul style="list-style-type: none">  >  Settings > Picture > Picture Mode Settings > Sharpness. You can try to increase or decrease the Sharpness. If you use an external antenna, check the direction, position and connection of the antenna. Adjust the direction of your antenna, or reset or fine tune the channel.
The picture appears red, purple, pink and other colors.	<ul style="list-style-type: none">  >  Settings > Picture > Picture Mode Settings > Expert Settings > White Balance. You can try to increase or decrease the White Balance.
Picture distorted or appears wavy.	<ul style="list-style-type: none"> Some electrical appliances may affect the TV. If you turn off the appliance and the interference goes away, then move it further away from TV. Insert the power plug of the TV into another power outlet.

Related information

[There is no picture, or the picture is black and white.](#) on page 51

Sound Issues

When the TV has a sound problem, these steps may help resolve the problem.

 >  **Settings > Support > Self Diagnosis > Sound Test**

If the TV plays the **Sound Test** melody without distortion, there may be a problem with an external device or the broadcast signal's strength.

Problem	Possible Solutions
Picture is normal, but no sound.	<ul style="list-style-type: none"> Check the volume settings. Check if 'Mute' mode is set to on. Check the volume control of the device (cable or satellite box, DVD, Blu-ray, etc.) connected to your TV.
The speakers are making an odd sound.	<ul style="list-style-type: none"> Make sure that the audio cable is connected to the correct audio output connector on the external device. For antenna or cable connections, check the signal information. A low signal level may cause sound distortions.
Sound distorted or appears wavy.	<ul style="list-style-type: none"> Some electrical appliances may affect the TV. If you turn off the appliance and the interference goes away, then move it further away from TV. Insert the power plug of the TV set into another power outlet.

Troubleshooting



Problem	Possible Solutions
Sound is blurry or cuts out momentarily.	<ul style="list-style-type: none">If you use an external antenna, check the direction, position and connection of the antenna.Adjust the direction of your antenna or reset or fine tune the channel.

Related information



[No sound or the sound is too low.](#) on page 52

Network Issues

When the TV has difficulties in connecting to the Internet, these steps may help resolve the problem.

 >  **Settings** > **Support** > **Self Diagnosis** > **Network Test**

If the TV network is connected, the screen will display Connected successfully.



Problem	Possible Solutions
The TV cannot connect to apps.	<ul style="list-style-type: none">Make sure the TV has a network connection.Run  >  Settings > Support > Self Diagnosis > Network TestContact your Internet service provider.
The wireless network connection failed.	<ul style="list-style-type: none">Make sure your wireless modem/router is on and connected to the Internet.
The wireless network signal is too weak.	<ul style="list-style-type: none">Position your wireless router, modem router, or access point in a central location. Avoid putting it in a corner.

Related information

[My TV cannot connect to the network.](#) on page 53

Channel and Broadcast Issues

For problems while watching live TV or scanning for new services, these suggestions might help to resolve any issues.

Problem	Possible Solutions
In Live TV, there is no signal, or a weak signal, or you cannot find any channels.	<ul style="list-style-type: none">Make sure that the antenna cable is connected to the correct port.Make sure that the antenna cable is not loose or disconnected.If "no signal or weak signal" occasionally happens, disconnect antenna cable and reconnect it.Run Reset to Factory Default or scan channels again.  >  Settings > Support > Factory Reset  > Settings > Channel > Auto Channel Scan

Related information





[Prepare Live TV](#) on page 6

[Channel Scan](#) on page 9

Troubleshooting

External Device Connection Issues

When the TV has difficulties with external device connection, these solutions may help resolve the problem.



Problem	Possible Solutions
The TV is having trouble receiving a signal from an external set top box.	<ul style="list-style-type: none">• If there is no signal occasionally, unplug cable from TV and re-plug after 60 seconds.• Change to another HDMI port.• Change to another HDMI cable.
There is no sound.	<ul style="list-style-type: none">• Check whether ARC is selected at  >  Settings > Sound > Audio Output Settings > Audio Output. If not, you need to check whether the external power amplifier device is connected to the ARC port or optical port of the TV.•  >  Settings > Sound > Audio Output Settings > Digital Audio Out. You can try to select Pass Through, PCM, AUTO, Dolby Auto - Dolby Digital, or Dolby Auto - Dolby Digital Plus.• Whether the power amplifier device port is connected correctly.

Related information

[External source connected but no picture or sound.](#)

HDMI & CEC Issues

When HDMI & CEC is not working, these steps may help resolve the problem.

Problem	Possible Solutions
HDMI & CEC does not work.	<ul style="list-style-type: none">• Confirm that the device is a HDMI & CEC compatible device.• Check if the power cable of the HDMI & CEC device is properly connected.• Check the cable connection of the HDMI & CEC device is secure.• Check CEC function of your TV is turned on.  >  Settings > System > HDMI-CEC > HDMI-CEC• Check HDMI & CEC feature of the connected device is turned on.• Depending on the connected HDMI device, the HDMI & CEC control feature may not work.





Related information

[Use HDMI-CEC on page 21](#)

Application Issues

When some apps will not play, this may help resolve the problem.

Troubleshooting

Problem	Possible Solutions
Netflix cannot be played.	<ul style="list-style-type: none">•  >  Settings > System > Application Settings > Netflix > Forced Closure, then reopen to try again.• You can try to reset to the factory settings at  >  Settings > Support > Factory Reset.

Media Files

When files will not play, this may help resolve the problem.

Problem	Possible Solutions
Some files cannot be played.	<ul style="list-style-type: none">• Most files can be played back, but you might experience problems with corrupted files or files with high-bitrate, unsupported resolution, unsupported container or codec formats.

Related information

[Media](#) on page 45

Voice Service Issues

When some Voice service will not function, this may help resolve the problem.

Problems	Possible Solutions
Alexa cannot be heard.	<ul style="list-style-type: none">• You can try to log into your Amazon account.• If you hear "I don't understand" from the voice recognition, please change account or log out of the account.• For more information about Alexa, please refer to Benefits of Smart TV >Using Voice Control > Alexa Setup in this manual.

Other Issues

Use these procedures to resolve other issues that may occur.

Problem	Possible Solutions
The TV is hot.	<ul style="list-style-type: none">• Watching TV for an extended period of time causes the panel to generate heat. The heat from the panel is dissipated through internal vents running along the top of the TV.• After extended use, you may feel heat when touching it. This heat is not a defect and does not affect the TV's functionality.
The TV smells of plastic.	<ul style="list-style-type: none">• This smell is normal and will dissipate over time.
The plastic cabinet makes a "clicking" type of sound.	<ul style="list-style-type: none">• The "clicking" sound can be caused when the temperature of the TV changes. This change causes the TV cabinet to expand or contract, which makes the sound. This is normal and the TV is OK.

Troubleshooting

Problem	Possible Solutions
When I turn on my TV, there is a delay for a few seconds before the picture appears. Is this normal?	<ul style="list-style-type: none">• Yes, this is normal. The TV is initialising and searching for the previous setting information.

Other ManualsLib Projects



www.manualslib.com



www.manualslib.de



www.manualslib.es



www.manualslib.fr



www.manualslib.nl



www.manualslib.mx



www.manualslib.tech 30+ Languages